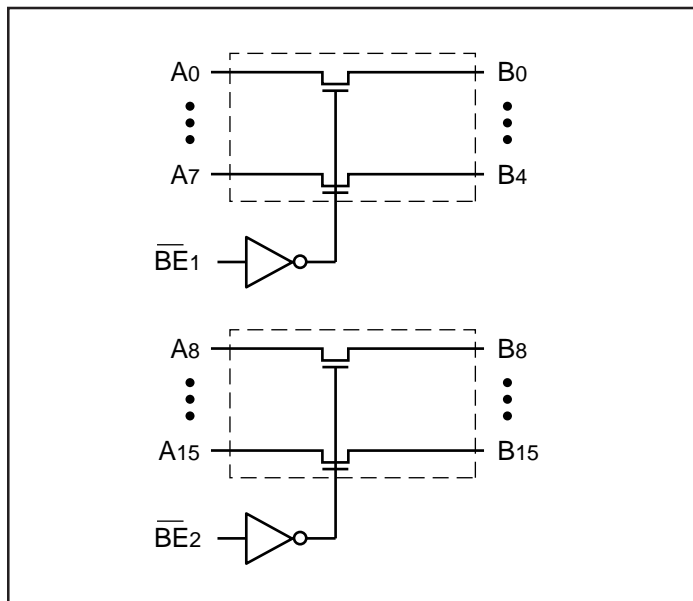
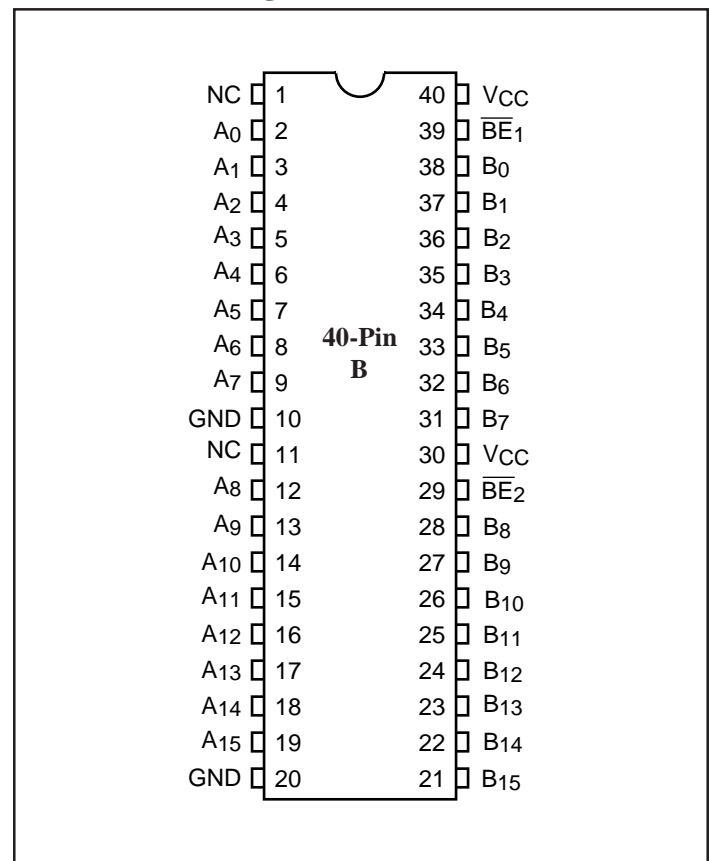

3.3V, Hot Insertion 16-Bit, 2-Port Bus Switch
Product Features

- Fast Switching Speed: 4.5ns max.
- Permits Hot Insertion
- Near-zero propagation delay
- 5Ω switches connect inputs to outputs
- Direct bus connection when switches are ON
- Ultra-low quiescent power (1.0μA typical)
 - Ideally suited for notebook applications
- Industrial operating temperature: -40°C to +85°C
- TTL - compatible control of input levels
- Packages (Pb-free & Green available):
 - 40-pin, 150-mil wide plastic BQSOP (B)

Logic Block Diagram

Product Description

The PI3B32X245 is a 3.3V, 16-bit, 2-port bus switch. Two enable signals (\overline{BE}_n) turn the switches on. The bus switch creates no additional propagational delay or additional ground bounce noise.

Product Pin Configuration

Truth Table⁽¹⁾

Function	\overline{BE}_n	A0-15
Disconnect	H	Hi-Z
Connect	L	B0-15

Notes:

1. H = High Voltage Level
L = Low Voltage Level
Hi-Z = High Impedance

Product Pin Description

Pin Name	I/O	Description
\overline{BE}_n	I	Bus Enable Input (Active LOW)
A0-A15	I/O	Bus A
B0-B15	I/O	Bus B

Maximum Ratings

(Above which the useful life may be impaired. For user guidelines, not tested.)

Storage Temperature	-65°C to +150°C
Ambient Temperature with Power Applied	-40°C to +85°C
Supply Voltage to Ground Potential (Inputs & V _{CC} Only) .	-0.5V to +4.6V
Supply Voltage to Ground Potential (Outputs & D/O Only)	-0.5V to +4.6V
DC Input Voltage	-0.5V to +7.0V
DC Output Current	120mA
Power Dissipation	0.5W

Note:

Stresses greater than those listed under MAXIMUM RATINGS may cause permanent damage to the device. This is a stress rating only and functional operation of the device at these or any other conditions above those indicated in the operational sections of this specification is not implied. Exposure to absolute maximum rating conditions for extended periods may affect reliability.

DC Electrical Characteristics (Over the Operating Range, T_A = -40°C to +85°C, V_{CC} = 3.3V ±10%)

Parameters	Description	Test Conditions ⁽¹⁾	Min.	Typ. ⁽²⁾	Max.	Units
V _{IH}	Input HIGH Voltage	Guaranteed Logic HIGH Level	2.0			V
V _{IL}	Input LOW Voltage	Guaranteed Logic LOW Level	-0.5		0.8	
I _{IH}	Input HIGH Current	V _{CC} = Max., V _{IN} = V _{CC}			±1	μA
I _{IL}	Input LOW Current	V _{CC} = Max., V _{IN} = GND				
I _{OZH}	High Impedence Output Current	0 ≤ A, B ≤ V _{CC}				
V _{IK}	Clamp Diode Voltage	V _{CC} = Min., I _{NN} = -18mA			-1.2	V
R _{ON}	Switch On Resistance ⁽⁴⁾	V _{CC} = Min., V _{IN} = 0.0V, I _{ON} = 48mA or 64mA		5	8	Ω
		V _{CC} = Min., V _{IN} = 2.4V, I _{ON} = 15mA		10	17	

Capacitance (T_A = 25°C, f = 1 MHz)

Parameters ⁽⁵⁾	Description	Test Conditions	Typ.	Units
C _{IN}	Input Capacitance	V _{IN} = 0V	3.5	pF
C _{OFF}	A/B Capacitance, Switch Off	V _{IN} = 0V	8.0	pF
C _{ON}	A/B Capacitance, Switch On	V _{IN} = 0V	16.0	pF

Notes:

1. For Max. or Min. conditions, use appropriate value specified under Electrical Characteristics for the applicable device type.
2. Typical values are at V_{CC} = 3.3V, T_A = 25°C ambient and maximum loading.
3. Not more than one output should be shorted at one time. Duration of the test should not exceed one second.
4. Measured by the voltage drop between A and B pin at indicated current through the switch. ON resistance is determined by the lower of the voltages on the two (A,B) pins.
5. This parameter is determined by device characterization but is not production tested.

Power Supply Characteristics

Parameters	Description	Test Conditions ⁽¹⁾		Min.	Typ. ⁽²⁾	Max.	Units
I _{CC}	Quiescent Power Supply Current	V _{CC} = Max.	V _{IN} = GND or V _{CC}		1.0	3.0	μA
ΔI _{CC}	Supply Current per Input @ TTL HIGH	V _{CC} = Max.	V _{IN} = 3.0V ⁽³⁾			750	μA

Notes:

1. For Max. or Min. conditions, use appropriate value specified under Electrical Characteristics for the applicable device.
2. Typical values are at V_{CC} = 3.3V, +25°C ambient.
3. Per TTL driven input (V_{IN} = 3.4V, control inputs only); A and B pins do not contribute to I_{CC}.
4. This current applies to the control inputs only and represent the current required to switch internal capacitance at the specified frequency. The A and B inputs generate no significant AC or DC currents as they transition. This parameter is not tested, but is guaranteed by design.

Switching Characteristics over Operating Range

Parameters	Description	Conditions ⁽¹⁾	PI3B32X245		Units
			Com.		
			Min.	Max.	
t _{PLH} t _{PHL}	Propagation Delay ^(2,3) Ax to Bx, Bx to Ax	C _L = 50pF R _L = 500Ω	—	0.25	ns
t _{PZH} t _{PZL}	Bus Enable Time BĒx to Ax or Bx		1.0	4.0	
t _{PHZ} t _{PLZ}	Bus Disable Time BĒx to Ax or Bx		1.0	4.5	

Notes:

1. See test circuit and waveforms.
2. This parameter is guaranteed but not tested on Propagation Delays.
3. The bus switch contributes no propagational delay other than the RC delay of the ON resistance of the switch and the load capacitance. The time constant for the switch alone is of the order of 0.25ns for 50pF load. Since this time constant is much smaller than the rise/fall times of typical driving signals, it adds very little propagational delay to the system. Propagational delay of the bus switch when used in a system is determined by the driving circuit on the driving side of the switch and its interaction with the load on the driven side.

Packaging Mechanical: 40-Pin BQSOP (B)

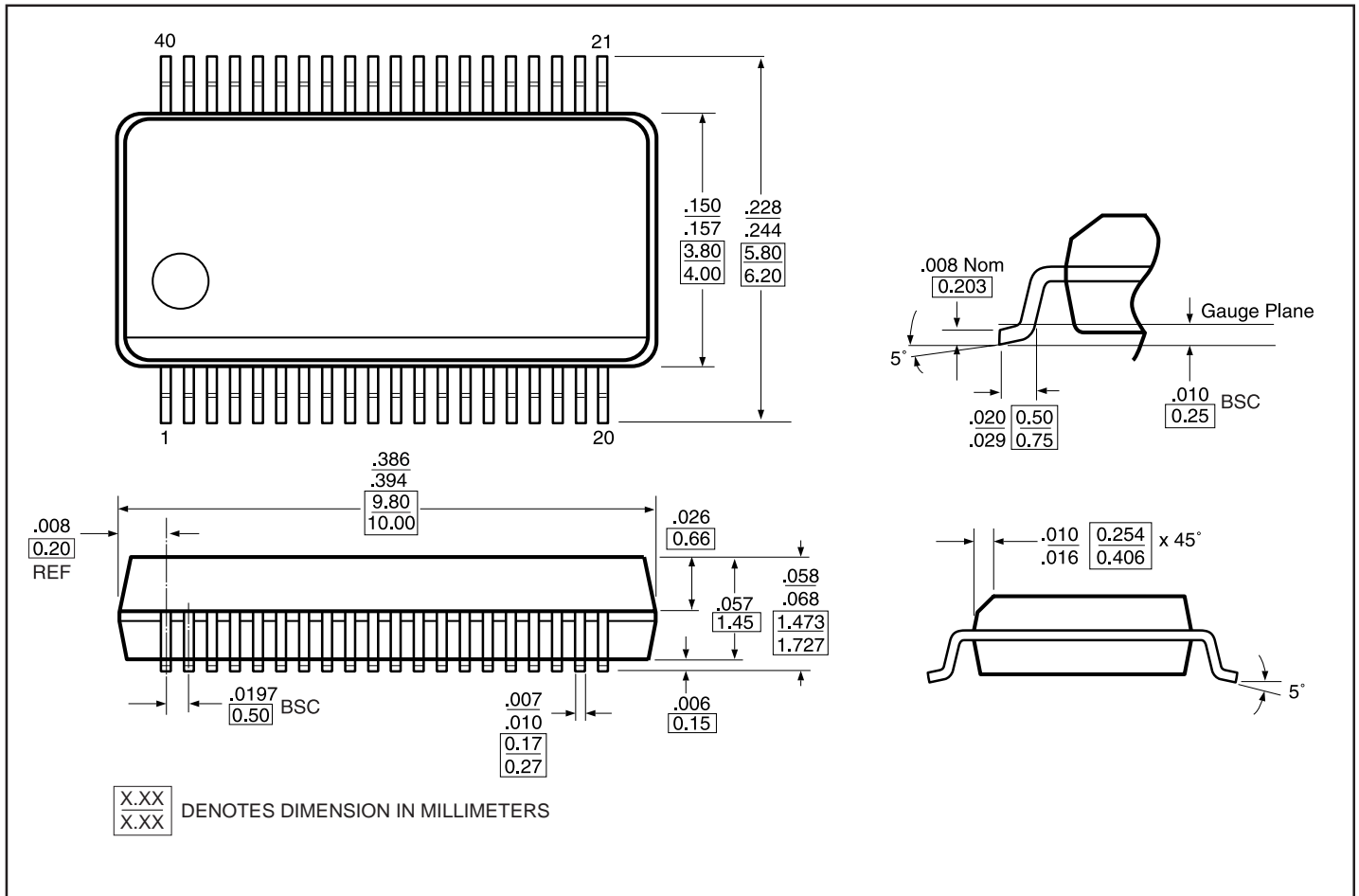

Ordering Information

Ordering Code	Package Type
PI3B32X245B	40-pin, 150-mil wide plastic BQSOP
PI3B32X245BE	Pb-free & Green, 40-pin, 150-mil wide plastic BQSOP