

2-Bit, 2-Port, Low Voltage Translator Bus Switch

Features

- Near-Zero propagation delay
- Low On-Resistance switches connect inputs to outputs
- 2.5V to 3.3V Supply Voltage Operation
- 2.5V or 1.8V switching
- Packaging (Pb-free & Green available):
 - 8-pin, 173-mil wide plastic TSSOP (L)
 - 8-pin, 118-mil wide plastic MSOP (U)

Applications

- 3.3V to 2.5V level shifting (voltage translation)
- 2.5V to 1.8V level shifting (voltage translation)

Description

Pericom Semiconductor's PI3VT3306 is a 2.5V or 3.3V 2-bit, 2-port bus switch designed with a low On-Resistance (5Ω). The switches are turned ON or enabled by the Bus Enable (\overline{BE}_n) input signal.

Given a 3.3V supply and an input voltage of 3.3V, the switch translates to an output voltage of 2.5V. Similarly, when operated with a 2.5V supply and given 2.5V inputs, the device translates the outputs to 1.8V.

Block Diagram

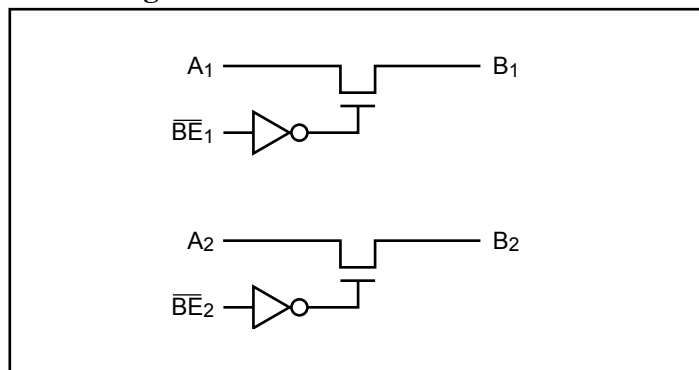

Pin Configuration

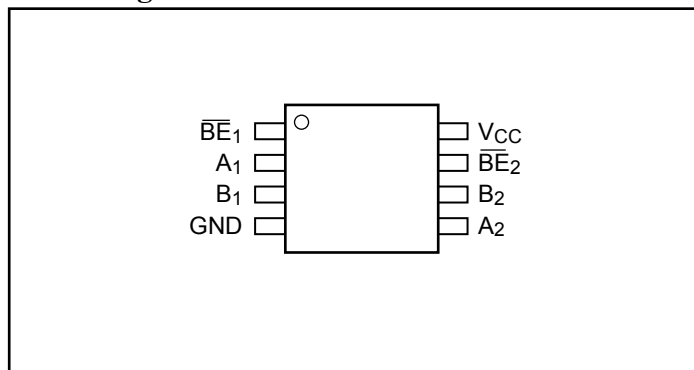

Truth Table(1)

\overline{BE}_n	A_n	B_n	V_{CC}	Function
X ⁽²⁾	Hi-Z	Hi-Z	GND	Disconnect
H	Hi-Z	Hi-Z	V_{CC}	Disconnect
L	B_n	A_n	V_{CC}	Connect

Notes:

1. H = High Voltage Level
L = Low Voltage Level
Hi-Z = High Impedance
X = Don't Care
2. A pull-up resistor should be provided for power-up protection

Pin Description

Pin Name	Description
\overline{BE}_n	Bus Enable Input (Active Low)
A_1 - A_2	Bus A
B_1 - B_2	Bus B
V_{CC}	Power
GND	Ground

Maximum Ratings

(Above which the useful life may be impaired. For user guidelines, not tested.)

Storage Temperature	-65°C to +150°C
Ambient Temperature with Power Applied	-40°C to +85°C
Supply Voltage to Ground Potential	-0.5V to +4.6V
DC Input Voltage	-0.5V to +5.5V
DC Output Current.....	120mA
Power Dissipation.....	0.5W

Note:

Stresses greater than those listed under MAXIMUM RATINGS may cause permanent damage to the device. This is a stress rating only and functional operation of the device at these or any other conditions above those indicated in the operational sections of this specification is not implied. Exposure to absolute maximum rating conditions for extended periods may affect reliability.

DC Electrical Characteristics (Over Operating Range, $T_A = -40^\circ\text{C}$ to $+85^\circ\text{C}$, $V_{CC} = 3.3\text{V} \pm 10\%$)

Parameters	Description	Test Conditions ⁽¹⁾	Min.	Typ. ⁽²⁾	Max.	Units
V_{IH}	Input HIGH Voltage	Guaranteed logic HIGH level	1.8		$V_{CC} + 0.3\text{V}$	V
V_{IL}	Input LOW Voltage	Guaranteed logic LOW level	-0.5		0.8	
I_{IH}	Input HIGH Current	$V_{CC} = \text{Max.}, V_{IN} = V_{CC}$			± 1	μA
I_{IL}	Input LOW Current	$V_{CC} = \text{Max.}, V_{IN} = \text{GND}$			± 1	
I_{OZH}	High Impedance Output Current	$0 \leq A, B \leq V_{CC}$			± 1	
R_{ON}	Switch On-Resistance	$V_{CC} = \text{Min.}, V_{IN} = 0\text{V}, I_{ON} = -8\text{mA}$		5	8	Ω
		$V_{CC} = \text{Min.}, V_{IN} = 1.7\text{V}, I_{ON} = -8\text{mA}$		10	22	
		$V_{CC} = 2.3\text{V}, V_{IN} = 0\text{V}, I_{ON} = -8\text{mA}$		6	9	
		$V_{CC} = 2.3\text{V}, V_{IN} = 1.3\text{V}, I_{ON} = -8\text{mA}$		25	30	
V_p	Pass Voltage	$V_{IN} = V_{CC} = 3.3\text{V}, I_{OUT} = -5\mu\text{A}$	2.3	2.5	2.9	V
		$V_{IN} = V_{CC} = 2.5\text{V}, I_{OUT} = -5\mu\text{A}$		1.8		

Capacitance ($T_A = 25^\circ\text{C}$, $f = 1\text{MHz}$)

Parameters ⁽⁵⁾	Description	Test Conditions	Typ.	Units
C_{IN}	Input Capacitance	$V_{IN} = 0\text{V}$	3.5	pF
C_{OFF}	A/B Capacitance, Switch Off		5.0	
C_{ON}	A/B Capacitance, Switch On		10.0	

Notes:

- For Max. or Min. conditions, use appropriate value specified under Electrical Characteristics for the applicable device type.
- Typical values are at $V_{CC} = 3.3\text{V}$, $T_A = 25^\circ\text{C}$ ambient and maximum loading.
- Not more than one output should be shorted at one time. Duration of the test should not exceed one second.
- Measured by the voltage drop between A and B pin at indicated current through the switch. On-Resistance is determined by the lower of the voltages on the two (A,B) pins.
- This parameter is determined by device characterization but is not production tested.

Power Supply Characteristics

Parameters	Description	Test Conditions ⁽¹⁾		Min.	Typ. ⁽²⁾	Max.	Units
I _{CC}	Quiescent Power Supply Current	V _{CC} = Max.	V _{IN} = GND or V _{CC}			3	μA
ΔI _{CC}	Quiescent Current per Input HIGH		V _{IN} = 3V ⁽³⁾			50	

Notes:

1. For Max. or Min. conditions, use appropriate value specified under Electrical Characteristics for the applicable device.
2. Typical values are at V_{CC} = 3.3V, +25°C ambient.
3. Per driven input (control input only); A and B pins do not contribute to ΔI_{CC}.

Switching Characteristics over 3.3V ±0.3V Operating Range

Parameters	Description	Conditions ⁽¹⁾	Com.		Units
			Min.	Max.	
t _{PLH} t _{PHL}	Propogation Delay ^(2,3) Ax to Bx	C _L = 50pF, R _L = 500Ω		0.25	ns
t _{PZH} t _{PZL}	Enable Time \overline{BE} to Ax or Bx	C _L = 50pF, R _L = 500Ω, R = 500Ω	1.5	6.5	
t _{PHZ} t _{PLZ}	Disable Time \overline{BE} to Ax or Bx		1.5	5.5	

Switching Characteristics over 2.5V ±0.2V Operating Range

Parameters	Description	Conditions ⁽¹⁾	Com.		Units
			Min.	Max.	
t _{PLH} t _{PHL}	Propogation Delay ^(2,3) Ax to Bx	C _L = 50pF, R _L = 500Ω		0.25	ns
t _{PZH} t _{PZL}	Enable Time \overline{BE} to Ax or Bx	C _L = 50pF, R _L = 500Ω, R = 500Ω	1.5	9.8	
t _{PHZ} t _{PLZ}	Disable Time \overline{BE} to Ax or Bx		1.5	8.3	

Notes:

1. See test circuit and waveforms.
2. This parameter is guaranteed but not tested on Propagation Delays.
3. The bus switch contributes no propagational delay other than the RC delay of the On-Resistance of the switch and the load capacitance. The time constant for the switch alone is of the order of 0.25ns for 50pF load. Since this time constant is much smaller than the rise/fall times of typical driving signals, it adds very little propagational delay to the system. Propagational delay of the bus switch when used in a system is determined by the driving circuit on the driving side of the switch and its interaction with the load on the driven side.

Packaging Mechanical: 8-pin TSSOP (L)

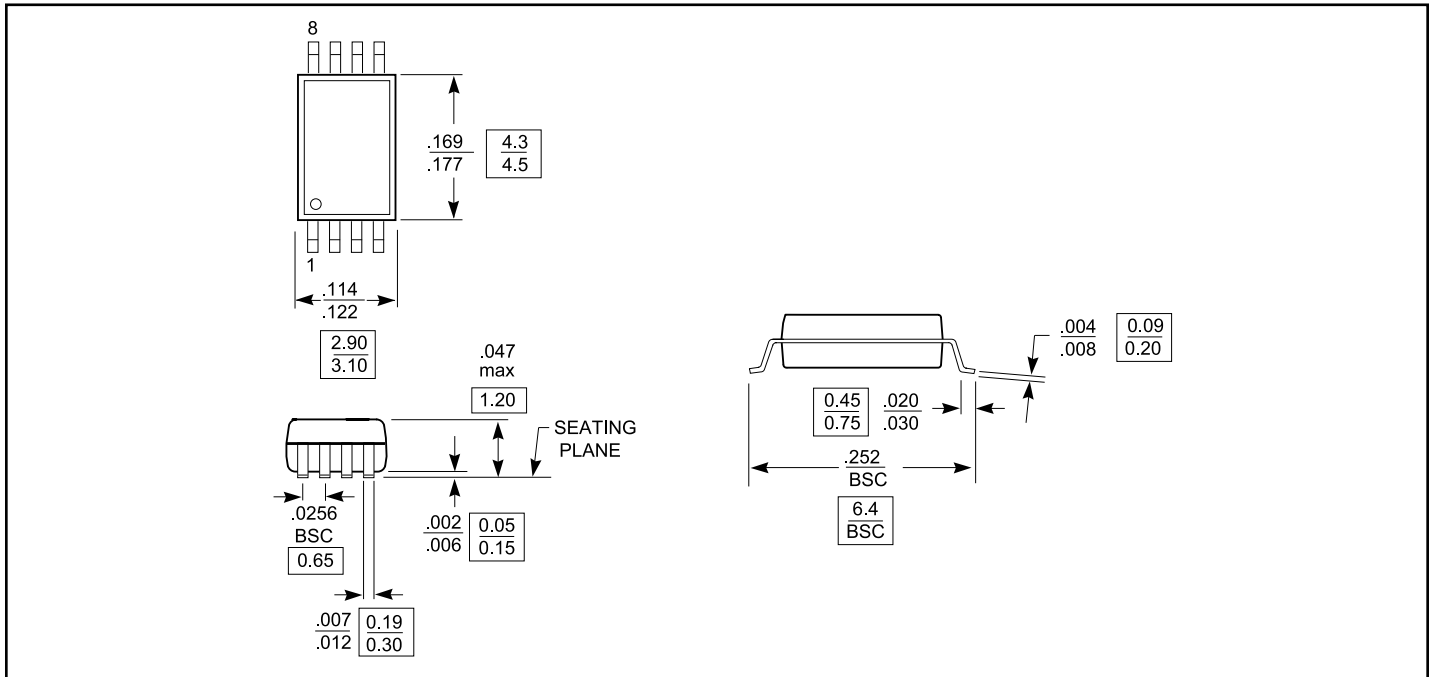

Packaging Mechanical: 8-pin MSOP (U)

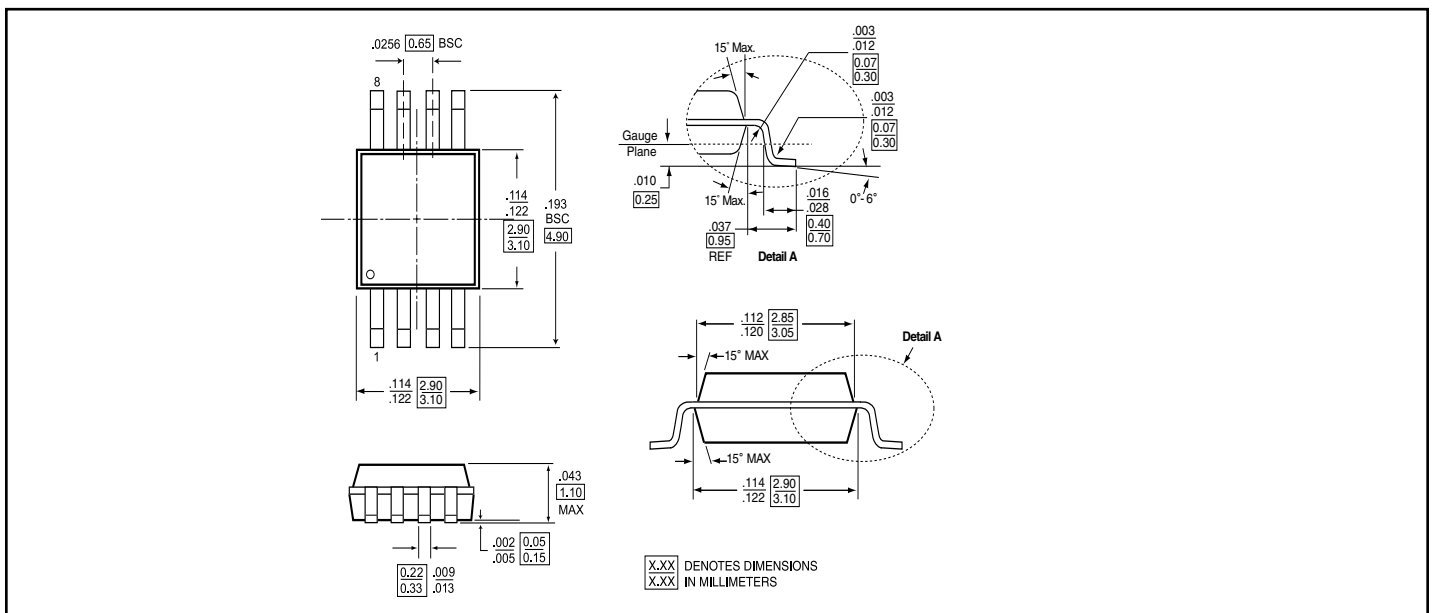

Ordering Information

Ordering Code	Packaging Code	Package Description
PI3VT3306L	L	8-pin TSSOP
PI3VT3306LE	L	Pb-free & Green, 8-pin TSSOP
PI3VT3306UX	U	8-pin MSOP
PI3VT3306UEX	U	Pb-free & Green, 8-pin MSOP

Notes:

1. Thermal characteristics can be found on the company web site at www.pericom.com/packaging/
2. X = Tape and Reel