

EVALUATION KIT
AVAILABLE

MAXIM

Dual, 10-Bit, 300Mps, Current-Output DAC with 4x/2x/1x Interpolation Filters

General Description

The MAX5858 dual, 10-bit, 300Mps digital-to-analog converter (DAC) provides superior dynamic performance in wideband communication systems. The MAX5858 integrates two 10-bit DAC cores, 2x/4x programmable digital interpolation filters, and a 1.24V reference. The MAX5858 supports single-ended and differential modes of operation. The MAX5858 dynamic performance is maintained over the entire power-supply operating range of 2.7V to 3.3V. The analog outputs support a compliance voltage of -1.0V to +1.25V.

The 4x/2x programmable interpolation filters feature excellent passband distortion and noise performance. Interpolating filters minimize the design complexity of analog reconstruction filters while lowering data bus and clock speeds of the digital interface. To reduce the I/O pin count, the DAC can also operate in interleave data mode. This allows the MAX5858 to be updated on a single 10-bit bus.

The MAX5858 features digital control of channel gain matching to within $\pm 0.4\text{dB}$ in 16 0.05dB steps. Channel matching improves sideband suppression in analog quadrature modulation applications. The on-chip 1.24V bandgap reference includes a control amplifier that allows external full-scale adjustments of both channels through a single resistor. The internal reference can be disabled and an external reference may be applied for high-accuracy applications.

The MAX5858 features full-scale current outputs of 2mA to 20mA and operates from a 2.7V to 3.3V single supply. The DAC supports three modes of power-control operation: normal, low-power standby, and complete power-down. In power-down mode, the operating current is reduced to 1 μA .

The MAX5858 is packaged in a 48-pin TQFP with exposed paddle (EP) for enhanced thermal dissipation and is specified for the extended (-40°C to +85°C) temperature range.

Applications

Communications
SatCom, LMDS, MMDS, HFC, DSL, WLAN,
Point-to-Point Microwave Links

Wireless Base Stations

Direct Digital Synthesis

Instrumentation/ATE

Features

- ◆ 10-Bit Resolution, Dual DAC
- ◆ 300Mps Update Rate
- ◆ Integrated 4x/2x Interpolating Filters
- ◆ 2.7V to 3.3V Single Supply
- ◆ Full Output Swing and Dynamic Performance at 2.7V Supply
- ◆ Superior Dynamic Performance
75dBc SFDR at $f_{\text{OUT}} = 20\text{MHz}$
UMTS ACLR = 63dB at $f_{\text{OUT}} = 30.7\text{MHz}$
- ◆ Programmable Channel-Gain Matching
- ◆ Integrated 1.24V Low-Noise Bandgap Reference
- ◆ Single-Resistor Gain Control
- ◆ Interleave Data Mode
- ◆ Differential Clock Input Modes
- ◆ EV Kit Available—MAX5858 EV Kit

Ordering Information

PART	TEMP RANGE	PIN-PACKAGE
MAX5858ECM	-40°C to +85°C	48 TQFP-EP*

*EP = Exposed paddle.

Pin Configuration

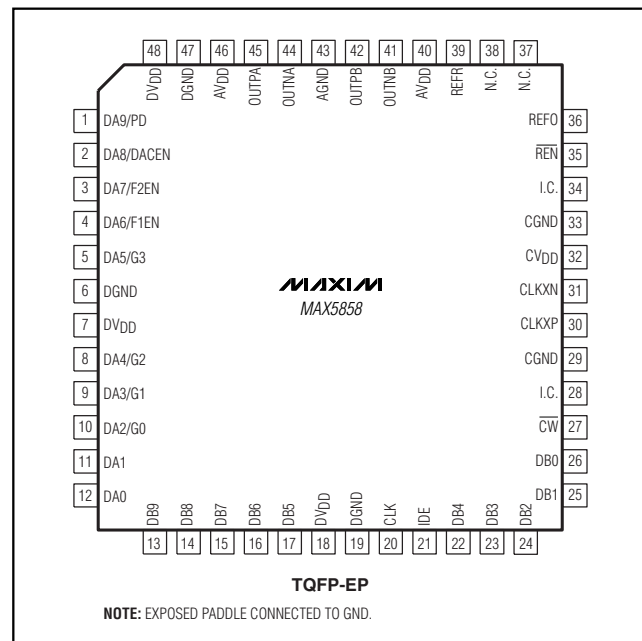

MAXIM

Maxim Integrated Products 1

For pricing, delivery, and ordering information, please contact Maxim/Dallas Direct! at 1-888-629-4642, or visit Maxim's website at www.maxim-ic.com.

MAX5858

Dual, 10-Bit, 300Mps, Current-Output DAC with 4x/2x/1x Interpolation Filters

ABSOLUTE MAXIMUM RATINGS

AV_{DD}, DV_{DD}, CV_{DD} to AGND, DGND, CGND-0.3V to +4V
 DA9-DA0, DB9-DB0, \overline{CW} , \overline{REN} to AGND,
 DGND, CGND-0.3V to +4V
 IDE to AGND, DGND, CGND.....-0.3V to (DV_{DD} + 0.3V)
 CLKXN, CLKXP to CGND-0.3V to +4V
 OUTP₋, OUTN₋ to AGND.....-1.25V to (AV_{DD} + 0.3V)
 CLK to DGND-0.3V to (DV_{DD} + 0.3V)
 REFR, REFO to AGND-0.3V to (AV_{DD} + 0.3V)

AGND to DGND, DGND to CGND,
 AGND to CGND.....-0.3V to +0.3V
 Maximum Current into Any Pin
 (excluding power supplies)±50mA
 Continuous Power Dissipation (T_A = +70°C)
 48-Pin TQFP-EP (derate 36.2mW/°C above +70°C)2.898W
 Operating Temperature Range-40°C to +85°C
 Storage Temperature Range-65°C to +150°C
 Junction Temperature+150°C
 Lead Temperature (soldering, 10s)+300°C

Stresses beyond those listed under "Absolute Maximum Ratings" may cause permanent damage to the device. These are stress ratings only, and functional operation of the device at these or any other conditions beyond those indicated in the operational sections of the specifications is not implied. Exposure to absolute maximum rating conditions for extended periods may affect device reliability.

ELECTRICAL CHARACTERISTICS

(AV_{DD} = DV_{DD} = CV_{DD} = 3V, AGND = DGND = CGND = 0, f_{DAC} = 165Mps, no interpolation, external reference, V_{REF} = 1.2V, I_{FS} = 20mA, output amplitude = 0dB FS, differential output, T_A = T_{MIN} to T_{MAX}, unless otherwise noted. T_A > +25°C guaranteed by production test. T_A < +25°C guaranteed by design and characterization. Typical values are at T_A = +25°C.)

PARAMETER	SYMBOL	CONDITIONS	MIN	TYP	MAX	UNITS
STATIC PERFORMANCE						
Resolution			10			Bits
Integral Nonlinearity	INL	R _L = 0	-1.25	±0.5	+1.25	LSB
Differential Nonlinearity	DNL	Guaranteed monotonic, R _L = 0	-0.75	±0.25	+0.75	LSB
Offset Error	V _{OS}		-0.5	±0.1	+0.5	LSB
Gain Error (See <i>Gain Error Parameter Definitions</i> Section)	GE	Internal reference (Note 1)	-9	±1.5	+10	%
		External reference	-5	±1.5	+7	
DYNAMIC PERFORMANCE						
Maximum Output DAC Update Rate	f _{DAC}		300			Mps
Glitch Impulse				5		pV-s
Spurious-Free Dynamic Range to Input Update Rate Nyquist	SFDR	f _{DAC} = 165Mps	f _{OUT} = 5MHz, T _A ≥ +25°C	69	76	dBc
			f _{OUT} = 20MHz		75	
			f _{OUT} = 40MHz		65	
			f _{OUT} = 60MHz		63	
		f _{DAC} = 300Mps, 2x interpolation	f _{OUT} = 5MHz		76	
			f _{OUT} = 40MHz		78	
Spurious-Free Dynamic Range Within a Window	SFDR	f _{DAC} = 200Mps, 2x interpolation; f _{OUT} = 40MHz, span = 20MHz		85	dBc	
		f _{DAC} = 165Mps, f _{OUT} = 5MHz, span = 4MHz	78	85		
Multitone Power Ratio, 8 Tones, 300kHz Spacing	MTPR	f _{DAC} = 165Mps, f _{OUT} = 20MHz		76		dBc
Adjacent Channel Leakage Ratio with UMTS	ACLR	f _{DAC} = 122.88Mps, f _{OUT} = 30.72MHz		63		dB

Dual, 10-Bit, 300Mps, Current-Output DAC with 4x/2x/1x Interpolation Filters

MAX5858

ELECTRICAL CHARACTERISTICS (continued)

(AVDD = DVDD = CVDD = 3V, AGND = DGND = CGND = 0, fDAC = 165Mps, no interpolation, external reference, VREF = 1.2V, IFS = 20mA, output amplitude = 0dB FS, differential output, TA = TMIN to TMAX, unless otherwise noted. TA > +25°C guaranteed by production test. TA < +25°C guaranteed by design and characterization. Typical values are at TA = +25°C.)

PARAMETER	SYMBOL	CONDITIONS	MIN	TYP	MAX	UNITS
Total Harmonic Distortion to Nyquist	THD	fDAC = 165Mps; fOUT = 5MHz		-72		dB
Noise Spectral Density	ND	fDAC = 165Mps; fOUT = 5MHz		-143		dBm/Hz
Output Channel-to-Channel Isolation		fOUT = 5MHz		80		dB
Gain Mismatch Between Channels		fOUT = 5MHz		±0.05		dB
Phase Mismatch Between Channels		fOUT = 5MHz		±0.15		Degrees
Wideband Output Noise				50		pA/√Hz
ANALOG OUTPUT						
Full-Scale Output Current Range	IFS		2		20	mA
Output Voltage Compliance Range			-1.00		+1.25	V
Output Leakage Current		Power-down or standby mode	-5		+5	µA
REFERENCE						
Reference Output Voltage	VREF0	REN = AGND	1.14	1.24	1.32	V
Output-Voltage Temperature Drift	TCVREF			±50		ppm/°C
Reference Output Drive Capability				50		µA
Reference Input Voltage Range		REN = AVDD	0.10		1.25	V
Reference Supply Rejection				0.2		mV/V
Current Gain	IFS/IREF			32		mA/mA
INTERPOLATION FILTER (2x interpolation)						
Passband Width	fOUT/ 0.5fDAC	-0.005dB		0.398		MHz/ MHz
		-0.01dB		0.402		
		-0.1dB		0.419		
		-3dB		0.478		
Stopband Rejection		0.604fDAC / 2 to 1.396fDAC / 2		74		dB
		0.600fDAC / 2 to 1.400fDAC / 2		62		
		0.594fDAC / 2 to 1.406fDAC / 2		53		
		0.532fDAC / 2 to 1.468fDAC / 2		14		
Group Delay				18		Data clock cycles
Impulse Response Duration				22		Data clock cycles

Dual, 10-Bit, 300Mps, Current-Output DAC with 4x/2x/1x Interpolation Filters

ELECTRICAL CHARACTERISTICS (continued)

($V_{DD} = DV_{DD} = CV_{DD} = 3V$, $AGND = DGND = CGND = 0$, $f_{DAC} = 165\text{Mps}$, no interpolation, external reference, $V_{REF} = 1.2V$, $I_{FS} = 20\text{mA}$, output amplitude = 0dB FS, differential output, $T_A = T_{MIN}$ to T_{MAX} , unless otherwise noted. $T_A > +25^\circ\text{C}$ guaranteed by production test. $T_A < +25^\circ\text{C}$ guaranteed by design and characterization. Typical values are at $T_A = +25^\circ\text{C}$.)

PARAMETER	SYMBOL	CONDITIONS	MIN	TYP	MAX	UNITS
INTERPOLATION FILTER (4x interpolation)						
Passband Width	$f_{OUT}/0.5f_{DAC}$	-0.005dB		0.200		MHz/ MHz
		-0.01dB		0.201		
		-0.1dB		0.210		
		-3dB		0.239		
Stopband Rejection		$0.302f_{DAC}/2$ to $1.698f_{DAC}/2$		74		dB
		$0.300f_{DAC}/2$ to $1.700f_{DAC}/2$		63		
		$0.297f_{DAC}/2$ to $1.703f_{DAC}/2$		53		
		$0.266f_{DAC}/2$ to $1.734f_{DAC}/2$		14		
Group Delay			22		Data clock cycles	
Impulse Response Duration			27		Data clock cycles	
LOGIC INPUTS (\overline{IDE}, \overline{CW}, \overline{REN}, DA9–DA0, DB9–DB0)						
Digital Input-Voltage High	V_{IH}		2			V
Digital Input-Voltage Low	V_{IL}				0.8	V
Digital Input-Current High	I_{IH}	$V_{IH} = 2V$	-1		+1	μA
Digital Input-Current Low	I_{IL}	$V_{IL} = 0.8V$	-1		+1	μA
Digital Input Capacitance	C_{IN}			3		pF
DIGITAL OUTPUTS (CLK)						
Digital Output-Voltage High	V_{OH}	$I_{SOURCE} = 0.5\text{mA}$, Figure 1		$0.9 \times DV_{DD}$		V
Digital Output-Voltage Low	V_{OL}	$I_{SINK} = 0.5\text{mA}$, Figure 1			$0.1 \times DV_{DD}$	V
DIFFERENTIAL CLOCK INPUT (CLKXP, CLKXN)						
Clock Input Internal Bias				$CV_{DD}/2$		V
Differential Clock Input Swing			0.5			V_{P-P}
Clock Input Impedance		Single-ended clock drive		5		$k\Omega$
TIMING CHARACTERISTICS						
Input Data Rate	f_{DATA}	No interpolation		165		Mps
		2x interpolation		150		
		4x interpolation		75		
Output Settling Time	t_s	To $\pm 0.1\%$ error band (Note 2)		11		ns
Output Rise Time		10% to 90% (Note 2)		2.5		ns
Output Fall Time		90% to 10% (Note 2)		2.5		ns

Dual, 10-Bit, 300Mps, Current-Output DAC with 4x/2x/1x Interpolation Filters

MAX5858

ELECTRICAL CHARACTERISTICS (continued)

(AVDD = DVDD = CVDD = 3V, AGND = DGND = CGND = 0, fDAC = 165Mps, no interpolation, external reference, VREF = 1.2V, IFS = 20mA, output amplitude = 0dB FS, differential output, TA = TMIN to TMAX, unless otherwise noted. TA > +25°C guaranteed by production test. TA < +25°C guaranteed by design and characterization. Typical values are at TA = +25°C.)

PARAMETER	SYMBOL	CONDITIONS	MIN	TYP	MAX	UNITS
DATA-to-CLK Rise Setup Time	tDCSR	(Note 3)	1.5			ns
DATA-to-CLK Rise Hold Time	tDCHR	(Note 3)	0.4			ns
DATA-to-CLK Fall Setup Time	tDCSF	(Note 3)	1.7			ns
DATA-to-CLK Fall Hold Time	tDCHF	(Note 3)	1.1			ns
Control Word to \overline{CW} Fall Setup Time	tCWS		2.5			ns
Control Word to \overline{CW} Fall Hold Time	tCWH		2.5			ns
\overline{CW} High Time			5			ns
\overline{CW} Low Time			5			ns
DACEN Rise-to-VOUT Stable	tSTB			0.7		μs
PD Fall-to-VOUT Stable	tpDSTB	External reference		0.5		ms
Clock Frequency at CLKXP/CLKXN Input	fDAC	Differential clock			300	MHz
CLKXP/CLKXN Differential Clock Input to CLK Output Delay	tcXD			4.6		ns
Minimum CLKXP/CLKXN Clock High Time	tcXH			1.5		ns
Minimum CLKXP/CLKXN Clock Low Time	tcXL			1.5		ns
POWER REQUIREMENTS						
Analog Power-Supply Voltage	AVDD		2.7		3.3	V
Analog Supply Current	IAVDD	(Note 4)		45	49	mA
Digital Power-Supply Voltage	DVDD		2.7		3.3	V

Dual, 10-Bit, 300Mps, Current-Output DAC with 4x/2x/1x Interpolation Filters

ELECTRICAL CHARACTERISTICS (continued)

($V_{DD} = DV_{DD} = CV_{DD} = 3V$, $AGND = DGND = CGND = 0$, $f_{DAC} = 165\text{Mpsps}$, no interpolation, external reference, $V_{REF} = 1.2V$, $I_{FS} = 20\text{mA}$, output amplitude = 0dB FS, differential output, $T_A = T_{MIN}$ to T_{MAX} , unless otherwise noted. $T_A > +25^\circ\text{C}$ guaranteed by production test. $T_A < +25^\circ\text{C}$ guaranteed by design and characterization. Typical values are at $T_A = +25^\circ\text{C}$.)

PARAMETER	SYMBOL	CONDITIONS		MIN	TYP	MAX	UNITS
Digital Supply Current (Note 4)	I_{DVDD}	$f_{DAC} = 60\text{Mpsps}$	No interpolation	34		mA	
			2x interpolation	75			
			4x interpolation	72			
		$f_{DAC} = 165\text{Mpsps}$	No interpolation	54	61		
			2x interpolation	146			
			4x interpolation	140			
		$f_{DAC} = 200\text{Mpsps}$	2x interpolation	172	186		
4x interpolation	165		178				
Clock Power-Supply Voltage	CV_{DD}			2.7		3.3	V
Clock Supply Current (Note 4)	I_{CVDD}	$f_{DAC} = 60\text{Mpsps}$		25		mA	
		$f_{DAC} = 165\text{Mpsps}$		69	80		
		$f_{DAC} = 200\text{Mpsps}$, 2x interpolation or 4x interpolation		80	94		
Standby Current	$I_{STANDBY}$	(Note 5)		4.4		4.8	mA
Power-Down Current	I_{PD}	(Note 5)		1			μA
Total Power Dissipation	P_{TOT}	$f_{DAC} = 60\text{Mpsps}$	No interpolation	312		mW	
			2x interpolation	435			
			4x interpolation	426			
		$f_{DAC} = 165\text{Mpsps}$	No interpolation	504	570		
			2x interpolation	780			
			4x interpolation	762			
		$f_{DAC} = 200\text{Mpsps}$	2x interpolation	891			
4x interpolation	870						

Note 1: Including the internal reference voltage tolerance.

Note 2: Measured single ended with 50Ω load and complementary output connected to ground.

Note 3: Guaranteed by design, not production tested.

Note 4: $f_{OUT} = 5\text{MHz}$.

Note 5: All digital inputs at 0 or DV_{DD} . Clock signal disabled.

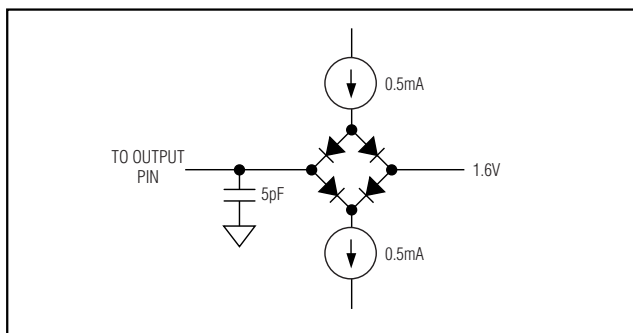

Figure 1. Load Test Circuit for CLK Outputs

Dual, 10-Bit, 300Mps, Current-Output DAC with 4x/2x/1x Interpolation Filters

MAX5858

Typical Operating Characteristics

($V_{DD} = DV_{DD} = CV_{DD} = 3V \pm 10\%$, $AGND = DGND = CGND = 0$, external reference = 1.2V, no interpolation, $I_{FS} = 20mA$, differential output, $T_A = +25^\circ C$, unless otherwise noted.)

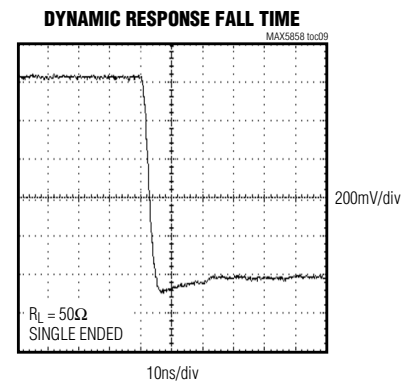
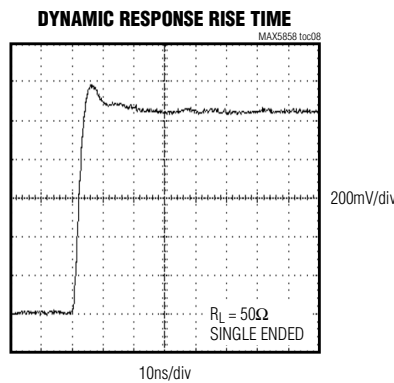
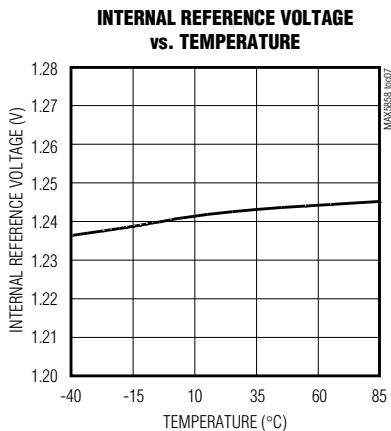
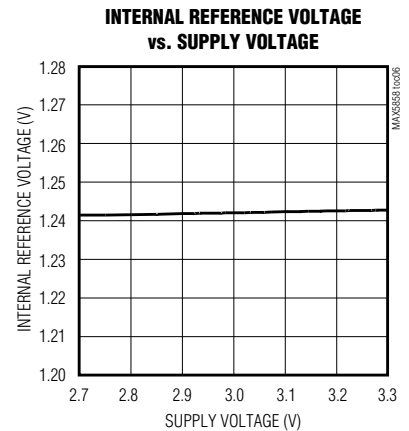
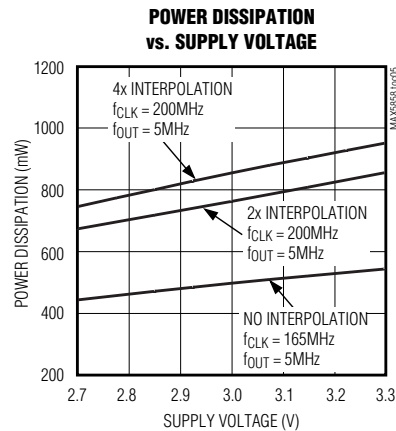
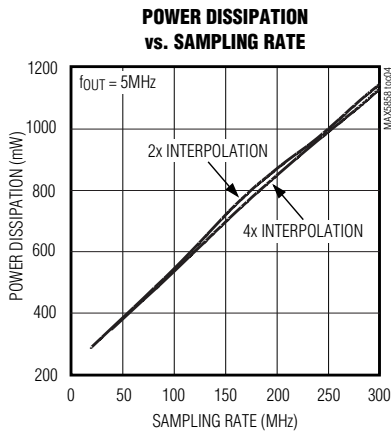
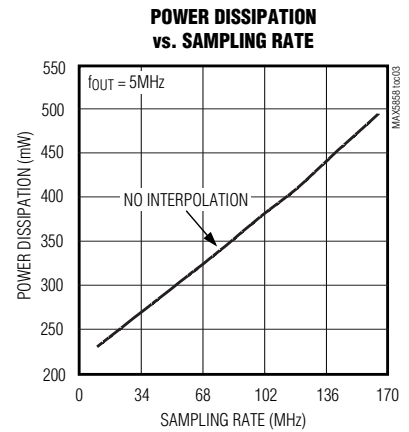
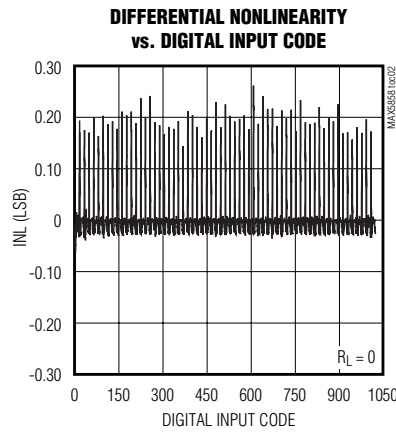
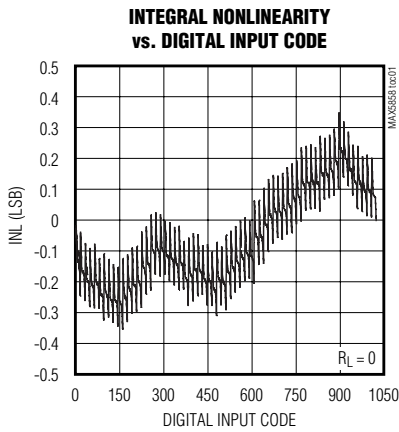

Dual, 10-Bit, 300Mps, Current-Output DAC with 4x/2x/1x Interpolation Filters

Typical Operating Characteristics (continued)

($V_{DD} = DV_{DD} = CV_{DD} = 3V \pm 10\%$, $AGND = DGND = CGND = 0$, external reference = 1.2V, no interpolation, $I_{FS} = 20mA$, differential output, $T_A = +25^\circ C$, unless otherwise noted.)

SPURIOUS-FREE DYNAMIC RANGE vs. OUTPUT FREQUENCY
(NO INTERPOLATION, $f_{DAC} = 165MHz$)

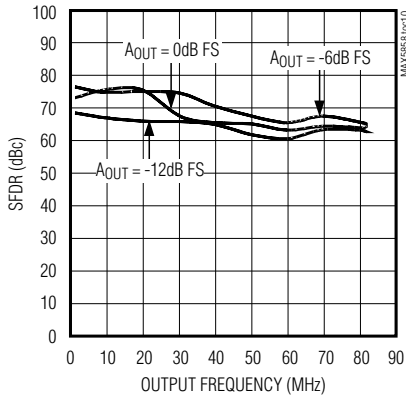

SPURIOUS-FREE DYNAMIC RANGE vs. OUTPUT FREQUENCY
(NO INTERPOLATION, $f_{DAC} = 65MHz$)

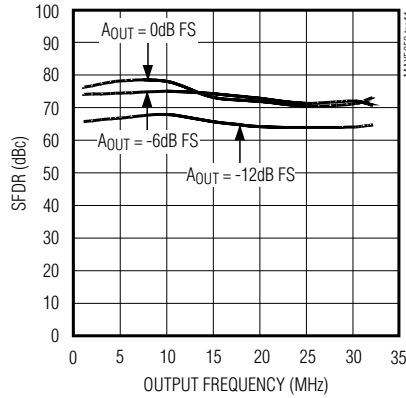

SPURIOUS-FREE DYNAMIC RANGE vs. OUTPUT FREQUENCY
(2x INTERPOLATION, $f_{DAC} = 300MHz$)

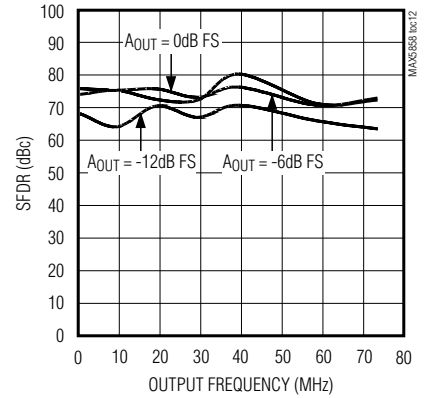

SPURIOUS-FREE DYNAMIC RANGE vs. OUTPUT FREQUENCY
(2x INTERPOLATION, $f_{DAC} = 165MHz$)

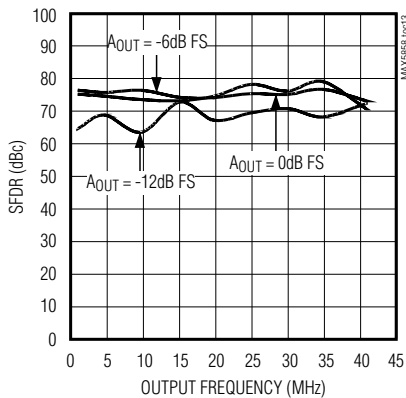

SPURIOUS-FREE DYNAMIC RANGE vs. OUTPUT FREQUENCY
(4x INTERPOLATION, $f_{DAC} = 300MHz$)

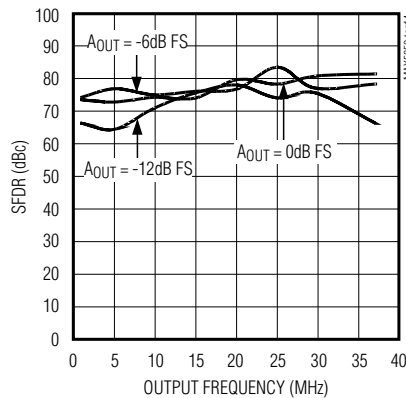

SPURIOUS-FREE DYNAMIC RANGE vs. OUTPUT FREQUENCY
(4x INTERPOLATION, $f_{DAC} = 165MHz$)

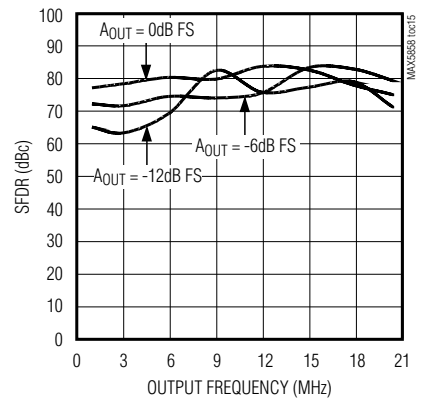

Dual, 10-Bit, 300Mps, Current-Output DAC with 4x/2x/1x Interpolation Filters

Typical Operating Characteristics (continued)

($V_{DD} = DV_{DD} = CV_{DD} = 3V \pm 10\%$, $AGND = DGND = CGND = 0$, external reference = 1.2V, no interpolation, $I_{FS} = 20mA$, differential output, $T_A = +25^\circ C$, unless otherwise noted.)

SPURIOUS-FREE DYNAMIC RANGE vs. TEMPERATURE (NO INTERPOLATION, $f_{DAC} = 165MHz$, $f_{OUT} = 5MHz$)

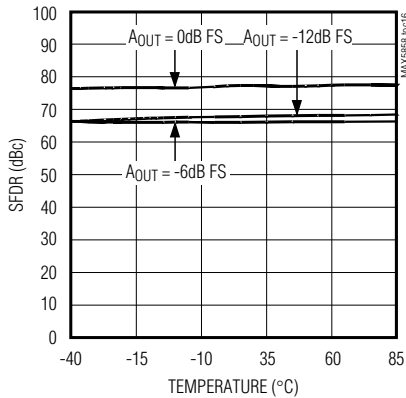

SPURIOUS-FREE DYNAMIC RANGE vs. OUTPUT FREQUENCY (NO INTERPOLATION, $f_{DAC} = 165MHz$)

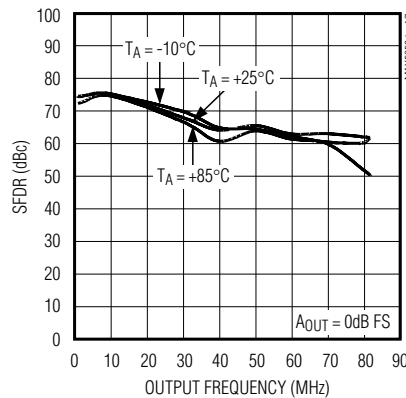

FFT PLOT ($\pm 2MHz$ WINDOW)

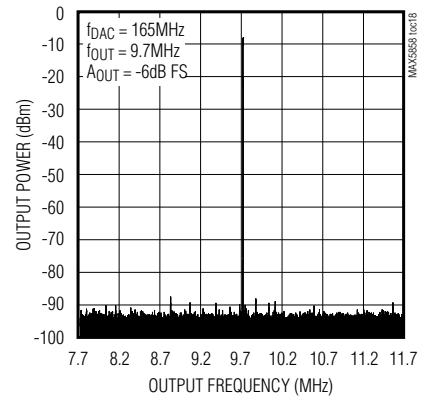

FFT PLOT FOR NYQUIST WINDOW (NO INTERPOLATION, $f_{DAC} = 165MHz$, $f_{OUT} = 10MHz$, $A_{OUT} = 0dB FS$)

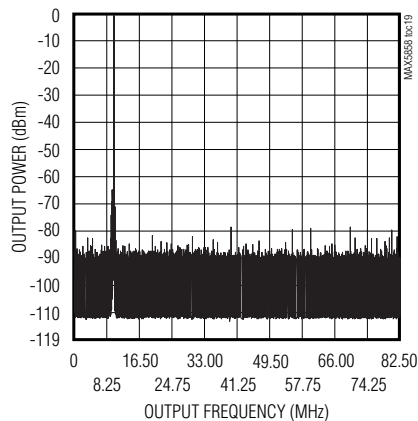

FFT PLOT FOR DAC UPDATE NYQUIST WINDOW (100MHz) (2x INTERPOLATION, $f_{DAC} = 200MHz$, $f_{OUT} = 10MHz$, $A_{OUT} = 0dB FS$)

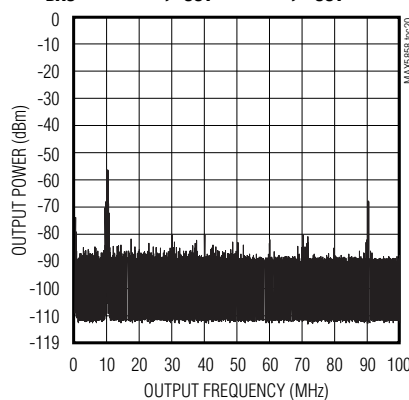

FFT PLOT FOR DAC UPDATE NYQUIST WINDOW (100MHz) (4x INTERPOLATION, $f_{DAC} = 200MHz$, $f_{OUT} = 10MHz$, $A_{OUT} = 0dB FS$)

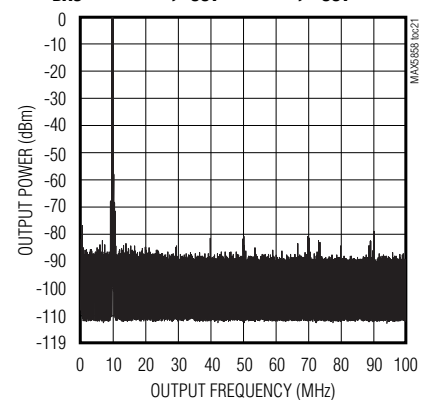

Dual, 10-Bit, 300Mps, Current-Output DAC with 4x/2x/1x Interpolation Filters

Typical Operating Characteristics (continued)

($V_{DD} = DV_{DD} = CV_{DD} = 3V \pm 10\%$, $AGND = DGND = CGND = 0$, external reference = 1.2V, no interpolation, $I_{FS} = 20mA$, differential output, $T_A = +25^\circ C$, unless otherwise noted.)

**2-TONE IMD PLOT
(NO INTERPOLATION, $f_{DAC} = 165MHz$)**

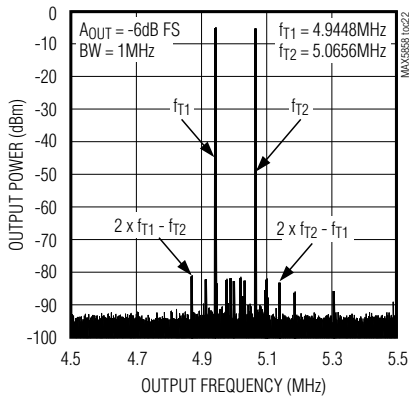

**8-TONE MTPR PLOT (NO INTERPOLATION,
 $f_{DAC} = 165MHz$, $f_{CENTER} = 19.9503MHz$)**

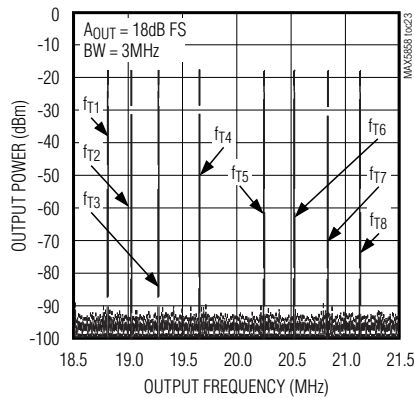

$f_{T1} = 18.8022MHz$ $f_{T5} = 20.2524MHz$
 $f_{T2} = 19.0237MHz$ $f_{T6} = 20.5344MHz$
 $f_{T3} = 19.2654MHz$ $f_{T7} = 20.8365MHz$
 $f_{T4} = 19.6481MHz$ $f_{T8} = 21.1386MHz$

**8-TONE MTPR PLOT (4x INTERPOLATION,
 $f_{DAC} = 286.4MHz$, $f_{CENTER} = 29.9572MHz$)**

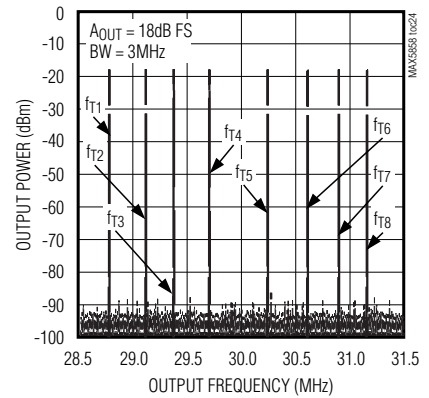

$f_{T1} = 28.7597MHz$ $f_{T5} = 30.2281MHz$
 $f_{T2} = 29.1008MHz$ $f_{T6} = 30.5952MHz$
 $f_{T3} = 29.3628MHz$ $f_{T7} = 30.8924MHz$
 $f_{T4} = 29.6862MHz$ $f_{T8} = 31.1546MHz$

**8-TONE MTPR PLOT FOR NYQUIST WINDOW
(NO INTERPOLATION, $f_{DAC} = 165MHz$,
 $f_{CENTER} = 19.9569MHz$, $A_{OUT} = -18dB FS$)**

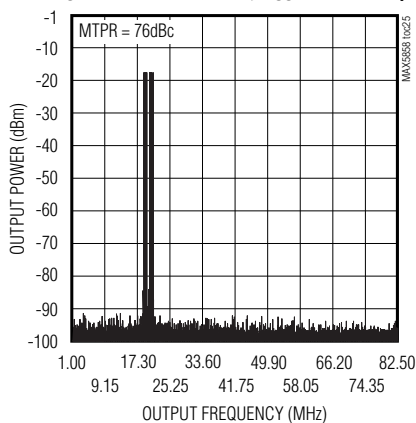

**8-TONE MTPR PLOT FOR DAC UPDATE
(WITHIN A NYQUIST WINDOW)
(x4 INTERPOLATION, $f_{DAC} = 286.4MHz$, $f_{CENTER} = 20MHz$,
INPUT TONES SPACED 300kHz APART, $A_{OUT} = -18dB FS$)**

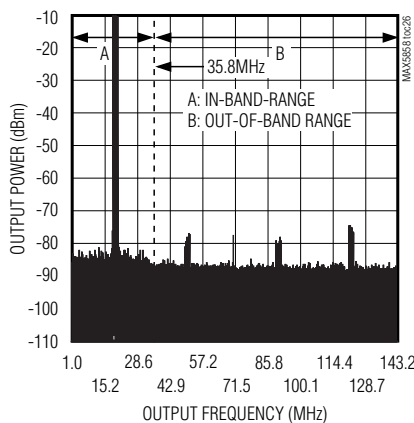

**ACLR UMS PLOT
(NO INTERPOLATION, $f_{DAC} = 122.88MHz$,
 $f_{DATA} = 122.88MHz$, $f_{CENTER} = 30.72MHz$)**

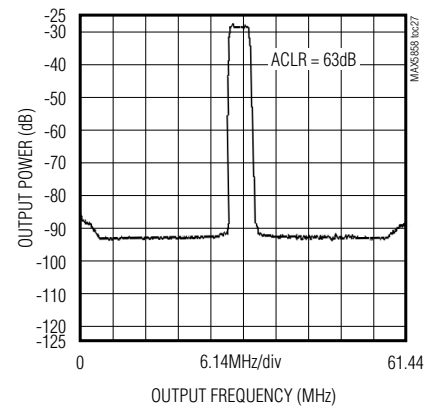

Dual, 10-Bit, 300Mps, Current-Output DAC with 4x/2x/1x Interpolation Filters

MAX5858

Typical Operating Characteristics (continued)

($V_{DD} = DV_{DD} = CV_{DD} = 3V \pm 10\%$, $AGND = DGND = CGND = 0$, external reference = 1.2V, no interpolation, $I_{FS} = 20mA$, differential output, $T_A = +25^\circ C$, unless otherwise noted.)

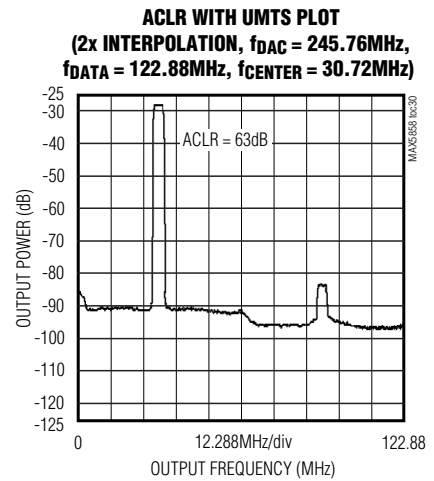
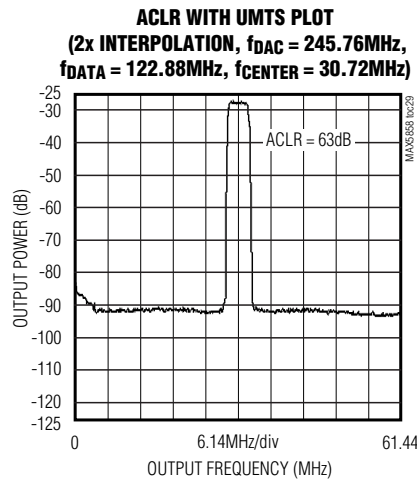
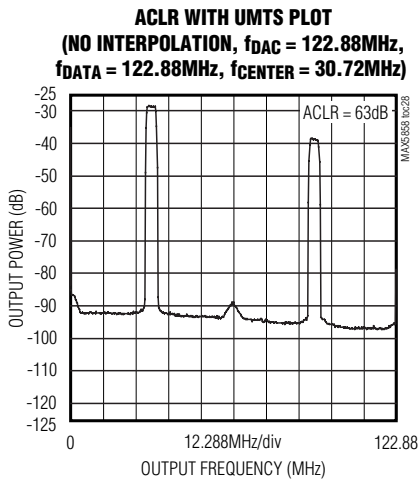

Pin Description

PIN	NAME	FUNCTION
1	DA9/PD	Channel A Input Data Bit 9 (MSB)/Power-Down Control Bit: 0: Enter DAC standby mode (DACEN = 0) or power up DAC (DACEN = 1). 1: Enter power-down mode.
2	DA8/DACEN	Channel A Input Data Bit 8/DAC Enable Control Bit: 0: Enter DAC standby mode with PD = 0. 1: Power up DAC with PD = 0. X: Enter power-down mode with PD = 1 (X = don't care).
3	DA7/F2EN	Channel A Input Data Bit 7/Second Interpolation Filter Enable Bit: 0: Interpolation mode is determined by F1EN. Enable 4x interpolation mode. (F1EN must equal 1.)
4	DA6/F1EN	Channel A Input Data Bit 6/First Interpolation Filter Enable Bit: 0: Interpolation disable. 1: Enable 2x interpolation.
5	DA5/G3	Channel A Input Data Bit 5/Channel A Gain Adjustment Bit 3
6, 19, 47	DGND	Digital Ground
7, 18, 48	DV _{DD}	Digital Power Supply. See the <i>Power Supplies, Bypassing, Decoupling, and Layout</i> section.
8	DA4/G2	Channel A Input Data Bit 4/Channel A Gain Adjustment Bit 2
9	DA3/G1	Channel A Input Data Bit 3/Channel A Gain Adjustment Bit 1

Dual, 10-Bit, 300Mps, Current-Output DAC with 4x/2x/1x Interpolation Filters

Pin Description (continued)

PIN	NAME	FUNCTION
10	DA2/G0	Channel A Input Data Bit 2/Channel A Gain Adjustment Bit 0
11	DA1	Channel A Input Data Bit 1
12	DA0	Channel A Input Data Bit 0 (LSB)
13	DB9	Channel B Input Data Bit 9 (MSB)
14	DB8	Channel B Input Data Bit 8
15	DB7	Channel B Input Data Bit 7
16	DB6	Channel B Input Data Bit 6
17	DB5	Channel B Input Data Bit 5
20	CLK	Clock Output
21	IDE	Interleave Data Mode Enable. When IDE is high, data for both DAC channels is written through port A (bits DA9–DA0). When IDE is low, channel A data is latched on the rising edge of CLK and channel B is latched on the falling edge of CLK.
22	DB4	Channel B Input Data Bit 4
23	DB3	Channel B Input Data Bit 3
24	DB2	Channel B Input Data Bit 2
25	DB1	Channel B Input Data Bit 1
26	DB0	Channel B Input Data Bit 0 (LSB)
27	\overline{CW}	Active-Low Control Word Write Pulse. The control word is latched on the falling edge of \overline{CW} .
28, 34	I.C.	Internally Connected. Do not connect.
29, 33	CGND	Clock Ground
30	CLKXP	Differential Clock Input Positive Terminal. Bypass CLKXP with a 0.01 μ F capacitor to CGND when CLKXN is in single-ended mode.
31	CLKXN	Differential Clock Input Negative Terminal. Bypass CLKXN with a 0.01 μ F capacitor to CGND when CLKXP is in single-ended mode.
32	CV _{DD}	Clock Power Supply. See the <i>Power Supplies, Bypassing, Decoupling, and Layout</i> section.
35	\overline{REN}	Active-Low Reference Enable. Connect \overline{REN} to AGND to activate the on-chip 1.24V reference.
36	REFO	Reference I/O. REFO serves as the reference input when the internal reference is disabled. If the internal 1.24V reference is enabled, REFO serves as the output for the internal reference. When the internal reference is enabled, bypass REFO to AGND with a 0.1 μ F capacitor.
37, 38	N.C.	No Connection. Not internally connected.
39	REFR	Full-Scale Current Adjustment. To set the output full-scale current, connect an external resistor RSET between REFR and AGND. The output full-scale current is equal to $32 \times V_{REFO}/R_{SET}$.
40, 46	AV _{DD}	Analog Power Supply. See <i>Power Supplies, Bypassing, Decoupling, and Layout</i> section.
41	OUTNB	Channel B Negative Analog Current Output
42	OUTPB	Channel B Positive Analog Current Output
43	AGND	Analog Ground
44	OUTNA	Channel A Negative Analog Current Output
45	OUTPA	Channel A Positive Analog Current Output
—	EP	Exposed Pad. Connect to the ground plane.

Dual, 10-Bit, 300Mps, Current-Output DAC with 4x/2x/1x Interpolation Filters

Simplified Block Diagram

MAX5858

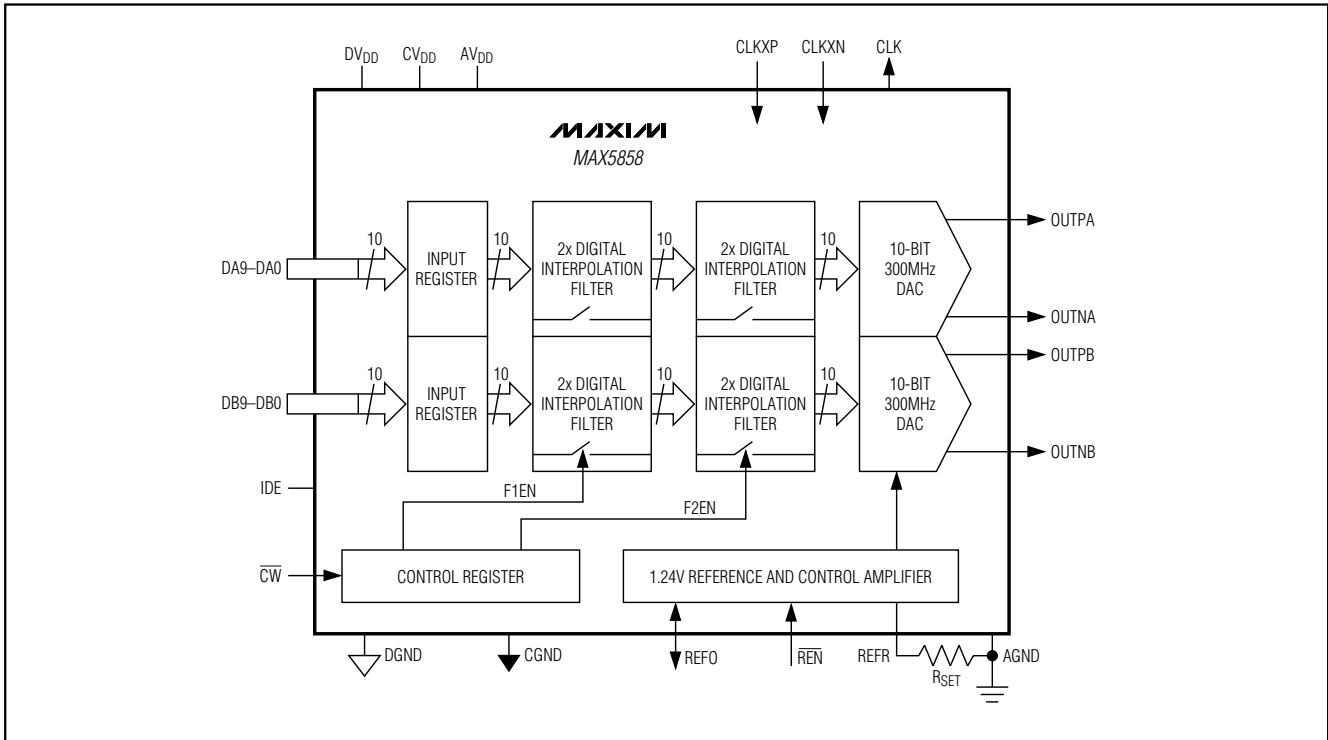

Detailed Description

The MAX5858 dual, high-speed, 10-bit, current-output DAC provides superior performance in communication systems requiring low-distortion analog-signal reconstruction. The MAX5858 combines two DACs with 2x/4x programmable digital interpolation filters, divide-by-N clock output, and an on-chip 1.24V reference. The current outputs of the DACs can be configured for differential or single-ended operation. The full-scale output current range is adjustable from 2mA to 20mA to optimize power dissipation and gain control.

The MAX5858 accepts an input data rate to 165MHz or a DAC conversion rate of 300MHz. The inputs are latched on the rising edge of the clock whereas the output latches on the following rising edge.

The two-stage digital interpolation filters are programmable to 4x, 2x, or no interpolation. When operating in 4x interpolation mode, the interpolator increases the DAC conversion by a factor of four, providing a four-

fold increase in separation between the reconstructed waveform spectrum and its first image.

The MAX5858 features three modes of operation: normal, standby, and power-down. These modes allow efficient power management. In power-down, the MAX5858 consumes only 1µA of supply current. Wake-up time from standby mode to normal DAC operation is 0.7µs.

Programming the DAC

An 8-bit control word routed through channel A's data port programs the gain matching, interpolator configuration, and operational mode of the MAX5858. The control word is latched on the falling edge of CW. Table 1 represents the control word format and function.

The gain on channel A can be adjusted to achieve gain matching between two channels in a user's system. The gain on channel A can be adjusted from -0.4dB to 0.35dB in steps of 0.05dB by using bits G3 to G0 (see Table 3).

Dual, 10-Bit, 300Mps, Current-Output DAC with 4x/2x/1x Interpolation Filters

Device Power-Up and States of Operation

At power-up, the MAX5858's default configuration is no-interpolation mode with a gain of 0dB and a fully operational converter. In shutdown, the MAX5858 consumes only 1 μ A of supply current, and in standby the current consumption is 4.4mA. Wake-up time from standby mode to normal operation is 0.7 μ s.

Interpolation Filters

The MAX5858 features a two stage, 2x digital interpolating filter based on 43-tap and 23-tap FIR topology. F1EN and F2EN enable the interpolation filters. F1EN high enables the first filter for 2x interpolation and F2EN high enables the second filter for combined 4x interpolation. To bypass and disable both interpolation filters (no-interpolation mode or 1x mode) set F1EN = F2EN = 0. When set for 1x mode the filters are powered down and consume virtually no current. An illegal condition is defined by: F1EN = 0, F2EN = 1 (see Table 2 for configuration modes).

The programmable interpolation filters multiply the MAX5858 input data rate by a factor of 2x or 4x to separate the reconstructed waveform spectrum and the first image. The original spectral images, appearing around multiples of the DAC input data rate, are attenuated at least 60dB by the internal digital filters. This feature provides three benefits:

- 1) Image separation reduces complexity of analog reconstruction filters.
- 2) Lower input data rates eliminate board level high-speed data transmission.
- 3) $\text{Sin}(x)/x$ roll-off is reduced over the effective bandwidth.

Figure 2 shows an application circuit and Figure 3 illustrates a practical example of the benefits when using the MAX5858 in 4x-interpolation mode. The example illustrates signal synthesis of a 20MHz IF with a ± 10 MHz bandwidth. The designer can consider three options to address the design challenge. The tradeoffs for each solution are depicted in Table 4.

Table 1. Control Word Format and Function

MSB								LSB	
PD	DACEN	F2EN	F1EN	G3	G2	G1	G0	X	X
CONTROL WORD		FUNCTION							
PD		Power-Down. The part enters power-down mode if PD = 1.							
DACEN		DAC Enable. When DACEN = 0 and PD = 0, the part enters standby mode.							
F2EN		Filter Enable. When F2EN = 1 and F1EN = 1, 4x interpolation is enabled. When F2EN = 0, the interpolation mode is determined by F1EN.							
F1EN		Filter Enable. When F1EN = 1 and F2EN = 0, 2x interpolation is active. With F1EN = 0 and F2EN = 0, the interpolation is disabled.							
G3		Bit 3 (MSB) of Gain Adjust Word.							
G2		Bit 2 of Gain Adjust Word.							
G1		Bit 1 of Gain Adjust Word.							
G0		Bit 0 (LSB) of Gain Adjust Word.							

Table 2. Configuration Modes

MODE	PD	DACEN	F2EN	F1EN
No interpolation	0	1	0	0
2x interpolation	0	1	0	1
4x interpolation	0	1	1	1
Standby	0	0	X	X
Power-down	1	X	X	X
Power-up	0	1	X	X

X = Don't care.

F1EN = 0, F2EN = 1 illegal.

Table 3. Gain Difference Setting

GAIN ADJUSTMENT ON CHANNEL A (dB)	G3	G2	G1	G0
+0.4	0	0	0	0
0	1	0	0	0
-0.35	1	1	1	1

Dual, 10-Bit, 300Mps, Current-Output DAC with 4x/2x/1x Interpolation Filters

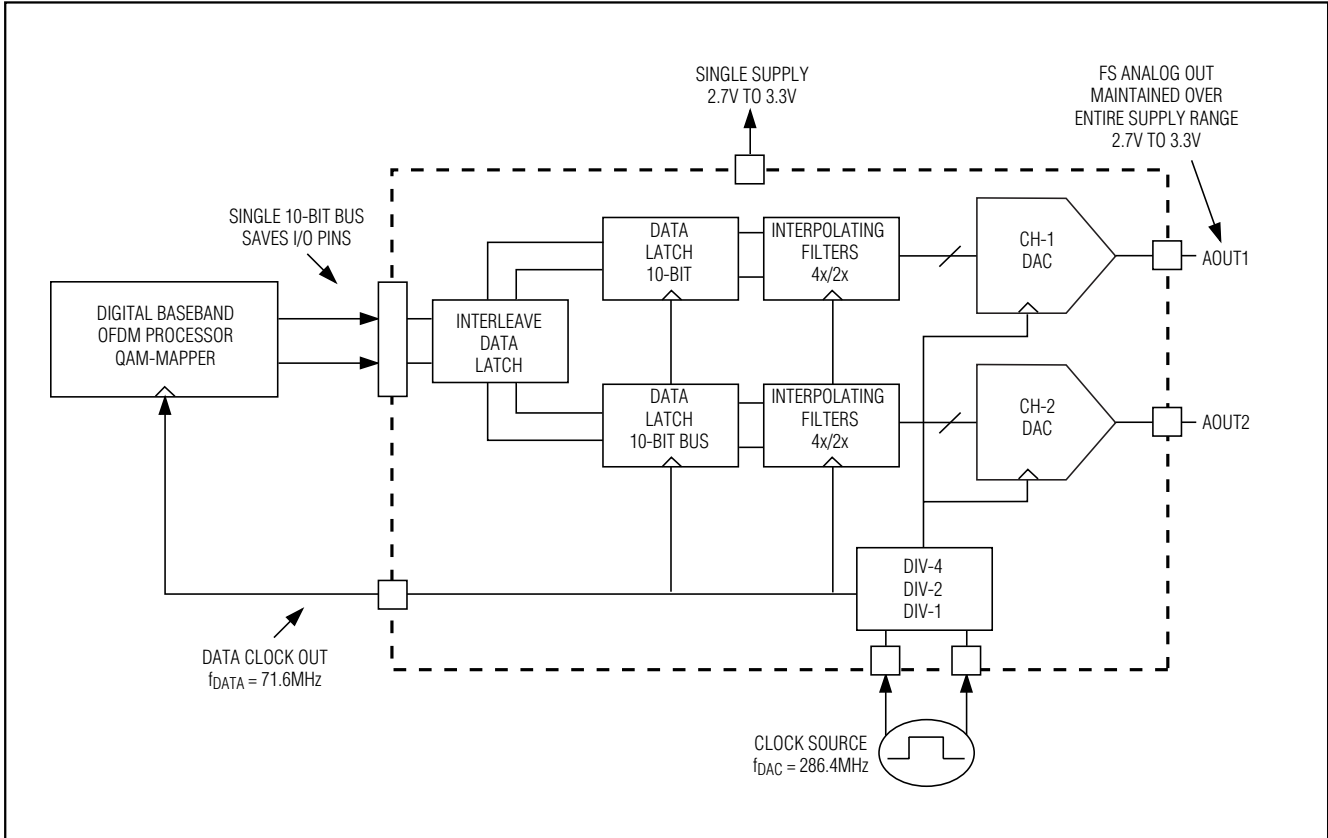

Figure 2. Typical Application Circuit

Table 4. Benefits of Interpolation

OPTION	SOLUTION	ADVANTAGE	DISADVANTAGE
1	<ul style="list-style-type: none"> No interpolation 2.6x oversample $f_{DAC} = f_{DATA} = 78\text{MHz}$ 	<ul style="list-style-type: none"> Low data rate Low clock rate 	<ul style="list-style-type: none"> High order filter Filter gain/phase match
2	<ul style="list-style-type: none"> No interpolation 8x oversample $f_{DAC} = f_{DATA} = 240\text{MHz}$ Push image to $f_{IMAGE} = 210\text{MHz}$ 	<ul style="list-style-type: none"> Lower order filter Filter gain/phase match 	<ul style="list-style-type: none"> High clock rate High data rate
3	<ul style="list-style-type: none"> 4x interpolation $f_{DAC} = 286.4\text{MHz}$, $f_{DATA} = 71.6\text{MHz}$ Passband attenuation = 0.1dB Push image to 256MHz 	<ul style="list-style-type: none"> Low data rate Low order filter 60dB image attenuate Filter gain/phase match 	<ul style="list-style-type: none"> None

Dual, 10-Bit, 300Mps, Current-Output DAC with 4x/2x/1x Interpolation Filters

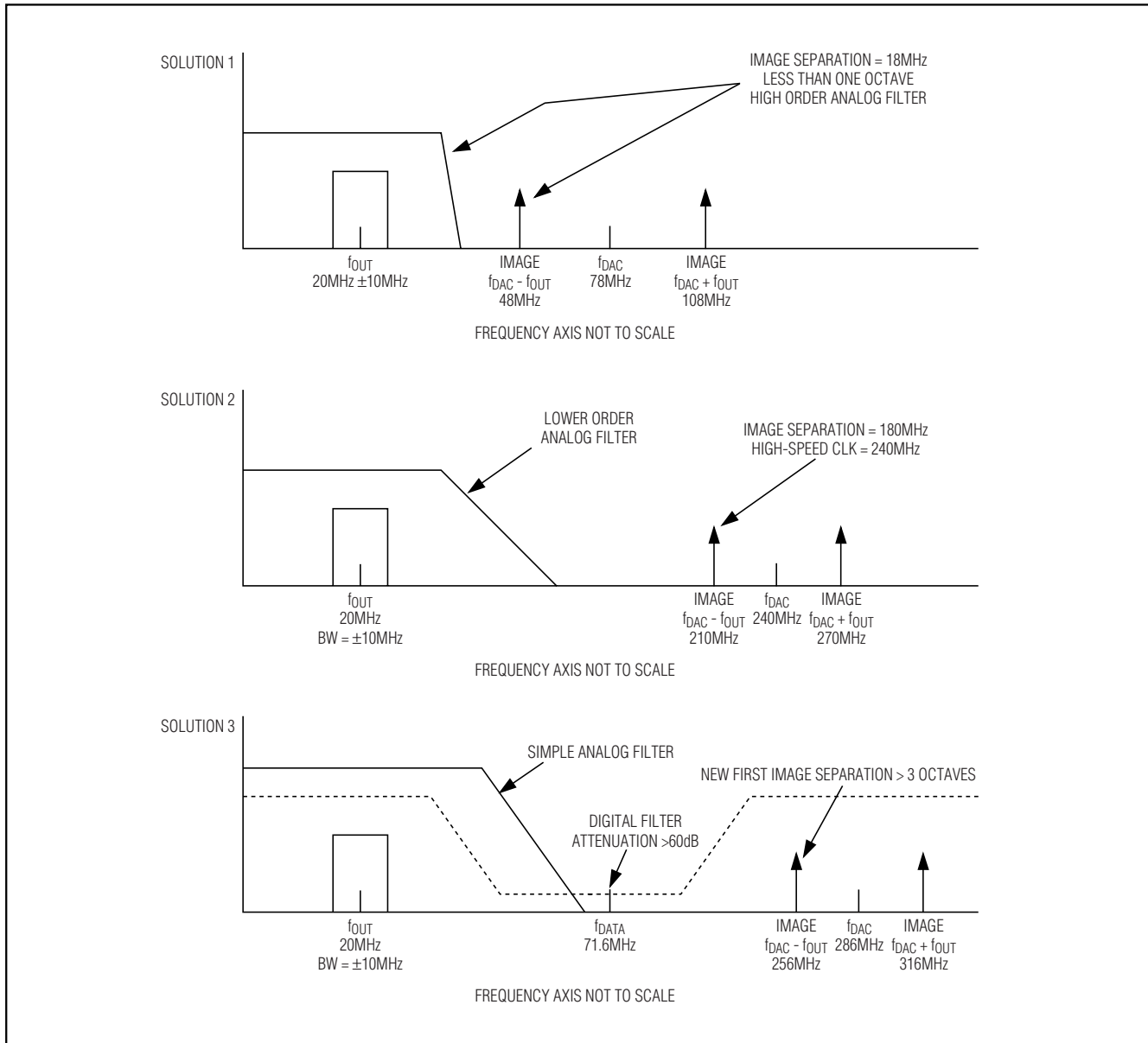

Figure 3. MAX5858 in 4x Interpolation Mode

This example demonstrates that 4x interpolation with digital filtering yields significant benefits in reducing system complexity, improving dynamic performance and lowering cost. Data can be written to the MAX5858 at much lower speeds while achieving image attenuation greater than 60dB and image separation beyond three octaves. The main benefit is in analog reconstruct-

tion filter design. Reducing the filter order eases gain/phase matching while lowering filter cost and saving board space. Because the data rate is lowered to 71.6MHz, the setup and hold times are manageable and the clock signal source is simplified, which results in improved system reliability and lower cost.

Dual, 10-Bit, 300MSPS, Current-Output DAC with 4x/2x/1x Interpolation Filters

MAX5858

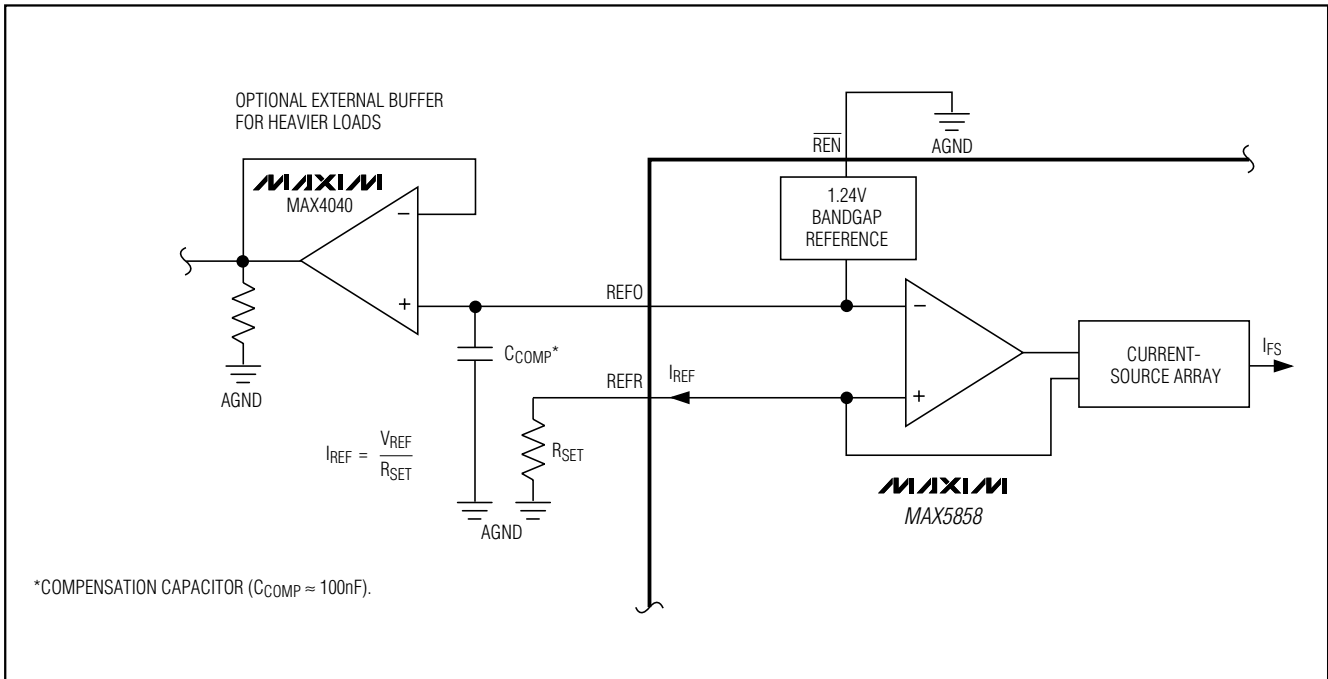

Figure 4. Setting I_{FS} with the Internal 1.24V Reference and the Control Amplifier

Clocking Modes

Apply an external clock to CLKXP and CLKXN at the desired DAC update rate and allowable input amplitude. CLK is an output and provides the signal necessary to synchronize the input data. CLKXP and CLKXN accept a frequency range of 0 to 300MHz (see Table 5). Maintain a low capacitive load at the CLK output (not higher than 10pF for f_{CLK} of 165MHz).

Internal Reference and Control Amplifier

The MAX5858 provides an integrated 50ppm/°C, 1.24V, low-noise bandgap reference that can be disabled and overridden with an external reference voltage. REFO serves either as an external reference input or an integrated reference output. If \overline{REN} is connected to AGND, the internal reference is selected and REFO provides a 1.24V (50µA) output. Buffer REFO with an external amplifier, when driving a heavy load.

The MAX5858 also employs a control amplifier designed to simultaneously regulate the full-scale output current (I_{FS}) for both outputs of the devices. Calculate the output current as:

$$I_{FS} = 32 \times I_{REF}$$

where I_{REF} is the reference output current ($I_{REF} = V_{REF}/R_{SET}$) and I_{FS} is the full-scale output current.

R_{SET} is the reference resistor that determines the amplifier output current of the MAX5858 (Figure 4). This current is mirrored into the current-source array where I_{FS} is equally distributed between matched current segments and summed to valid output current readings for the DACs.

External Reference

To disable the internal reference of the MAX5858, connect \overline{REN} to AV_{DD} . Apply a temperature-stable, external reference to drive the REFO to set the full-scale output (Figure 5). For improved accuracy and drift performance, choose a fixed output voltage reference such as the 1.24V, 25ppm/°C MAX6520 bandgap reference.

Detailed Timing

The MAX5858 accepts an input data rate up to 165MHz or the DAC conversion rate of 300MHz. The input latches on the rising edge of the clock, whereas the output latches on the following rising edge.

Figure 6 depicts the write cycle of the DACs in 4x interpolation mode. In this timing diagram, signals applied to CLKXP and CLKXN are divided by four to create the DAC's CLK signal. The MAX5858 DAC output is updated at the rate of the clock applied to CLKXP/CLKXN.

Dual, 10-Bit, 300MSPS, Current-Output DAC with 4x/2x/1x Interpolation Filters

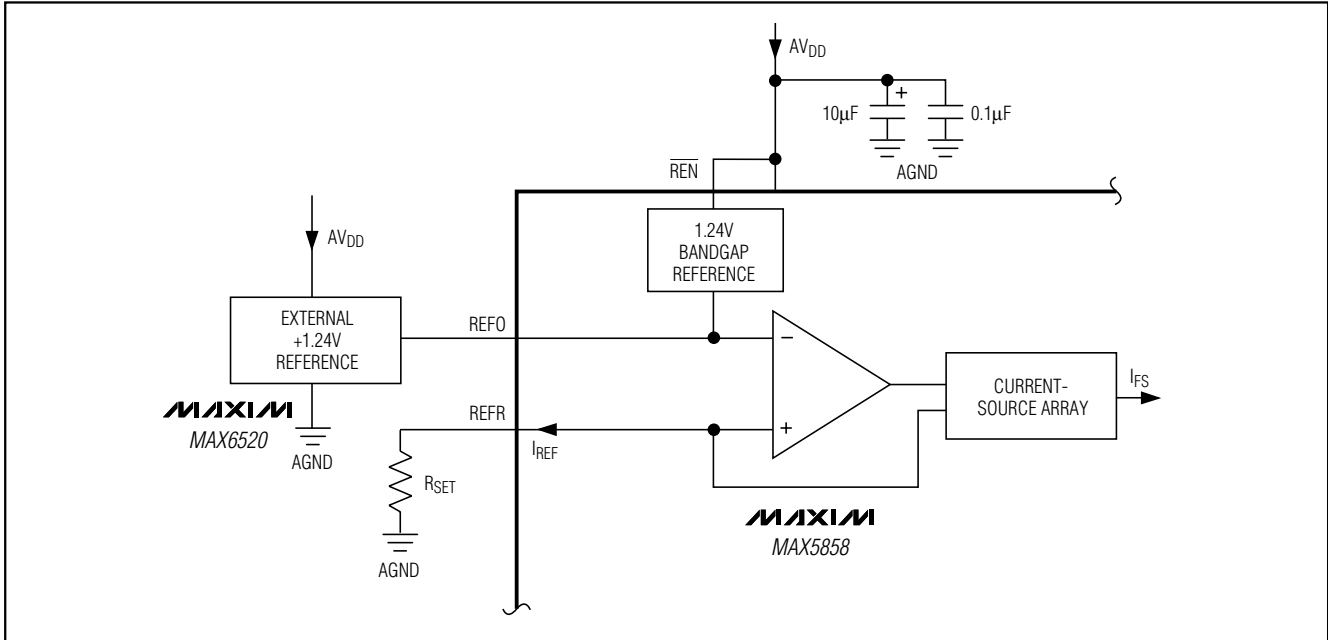

Figure 5. MAX5858 with External Reference

Table 5. Clocking Modes

F2EN	F1EN	DIFFERENTIAL CLOCK FREQUENCY (f _{CLKDIFF}) (MHz)	CLK OUTPUT (MHz)	DAC RATE (f _{DAC})	INTERPOLATION	MAX SIGNAL BANDWIDTH (MHz)	
0	0	0 to 165	f _{CLKDIFF}	f _{CLKDIFF}	1x	82	
0	1	0 to 300	f _{CLKDIFF} /2	f _{CLKDIFF}	2x	63	
1	1	0 to 300	f _{CLKDIFF} /4	f _{CLKDIFF}	4x	31	
1	0	Illegal					

The MAX5858 can also operate in an interleave data mode. Pulling IDE high activates this mode. In interleave mode, data for both DAC channels is written through input port A. Channel B data is written on the falling edge of the CLK signal and then channel A data is written on the following rising edge of the CLK signal. Both DAC outputs (channel A and B) are updated simultaneously on the next following rising edge of the CLK. In interleave data mode, the maximum input data rate per channel is half of the rate in noninterleave mode. The interleave data mode is attractive in applications where lower data rates are acceptable and interfacing on a single 10-bit bus is desired (Figure 7).

Applications Information

Differential-to-Single-Ended Conversion

The MAX5858 exhibits excellent dynamic performance to synthesize a wide variety of modulation schemes, including high-order QAM modulation with OFDM.

Figure 8 shows a typical application circuit with output transformers performing the required differential-to-single-ended signal conversion. In this configuration, the MAX5858 operates in differential mode, which reduces even-order harmonics, and increases the available output power.

Dual, 10-Bit, 300Mps, Current-Output DAC with 4x/2x/1x Interpolation Filters

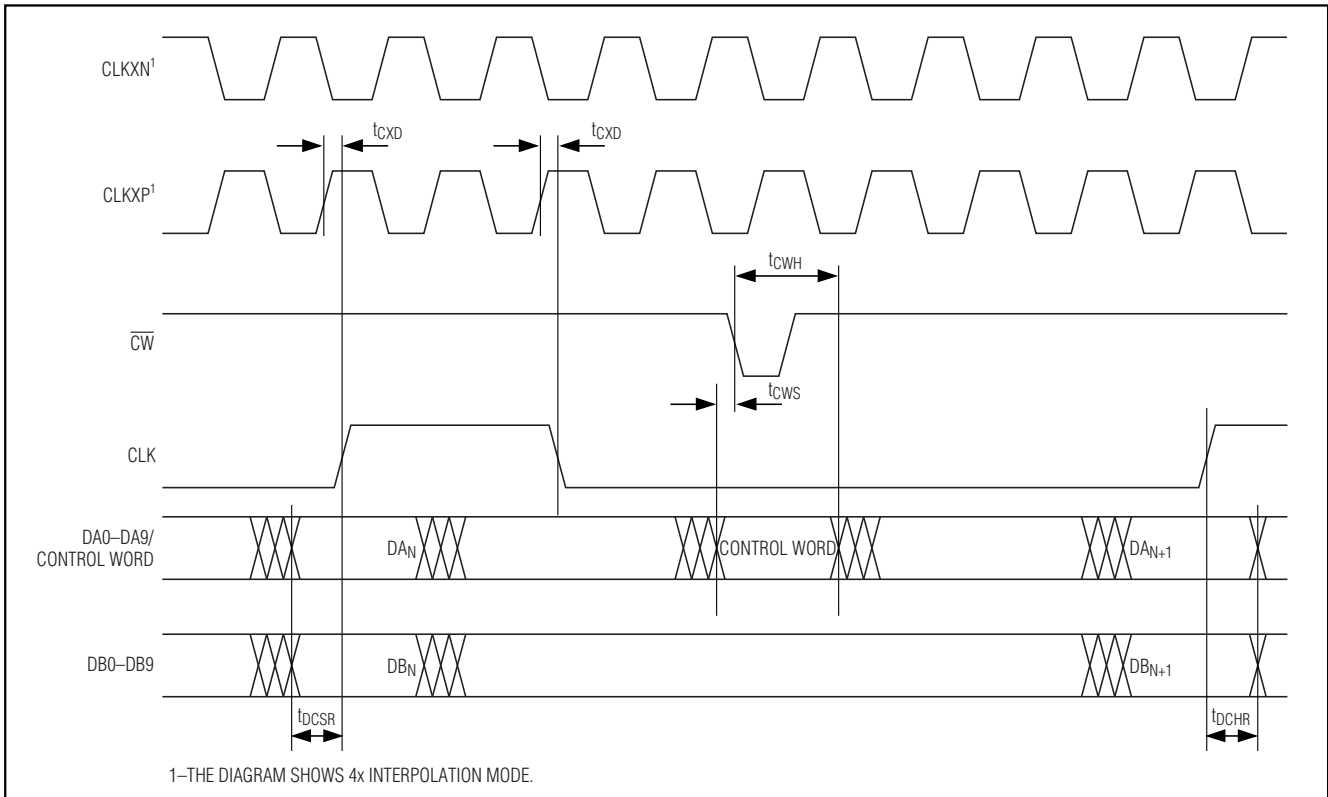

Figure 6. Timing Diagram for Noninterleave Data Mode ($IDE = Low$)

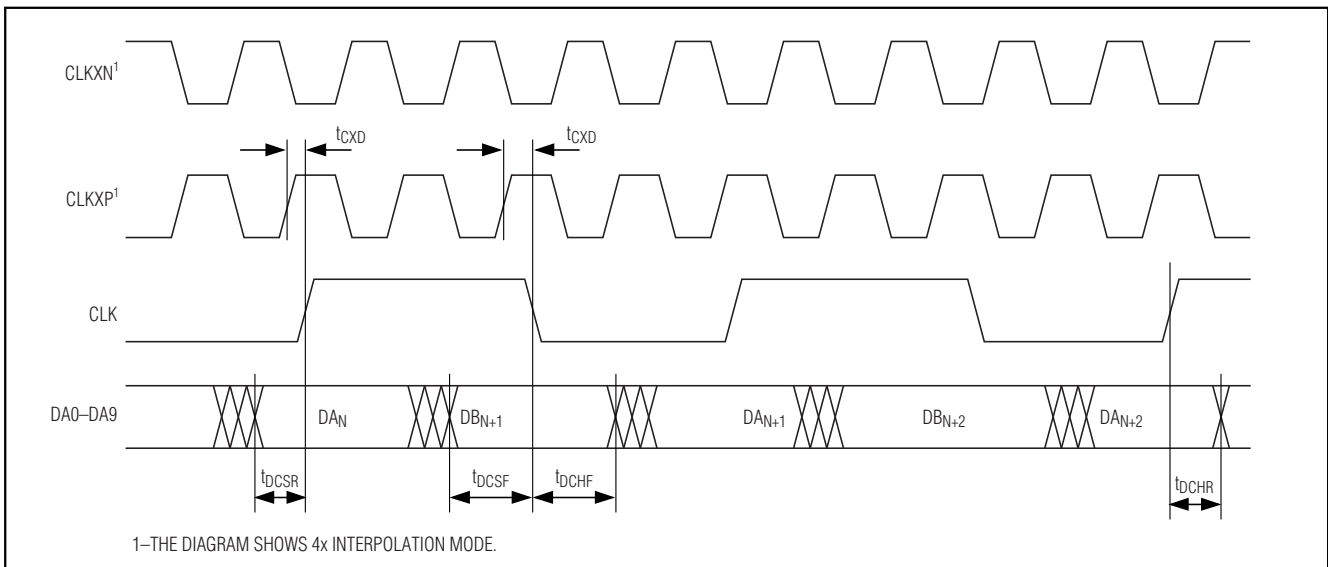

Figure 7. Timing Diagram for Interleave Data Mode ($IDE = High$)

Dual, 10-Bit, 300Mps, Current-Output DAC with 4x/2x/1x Interpolation Filters

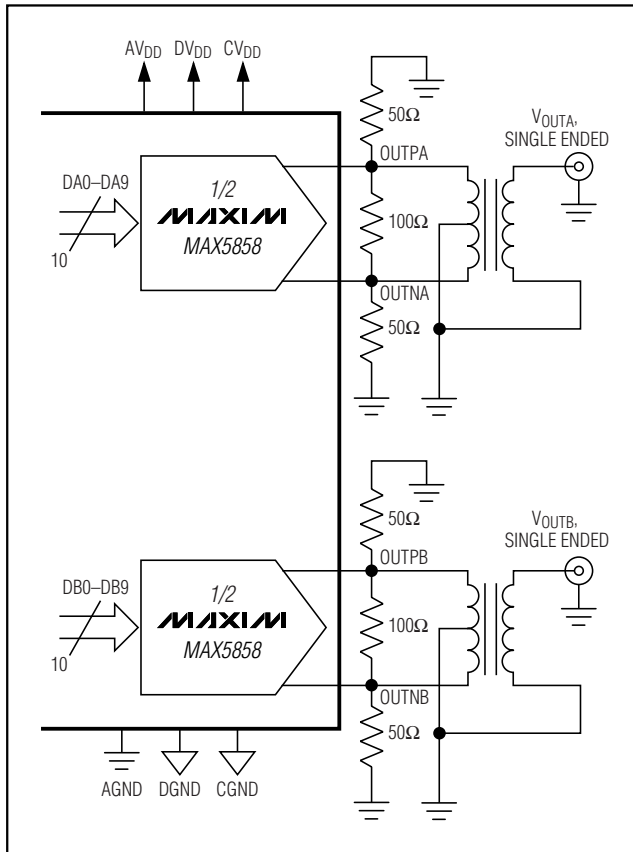

Figure 8. Application with Output Transformer Performing Differential to Single-Ended Conversion

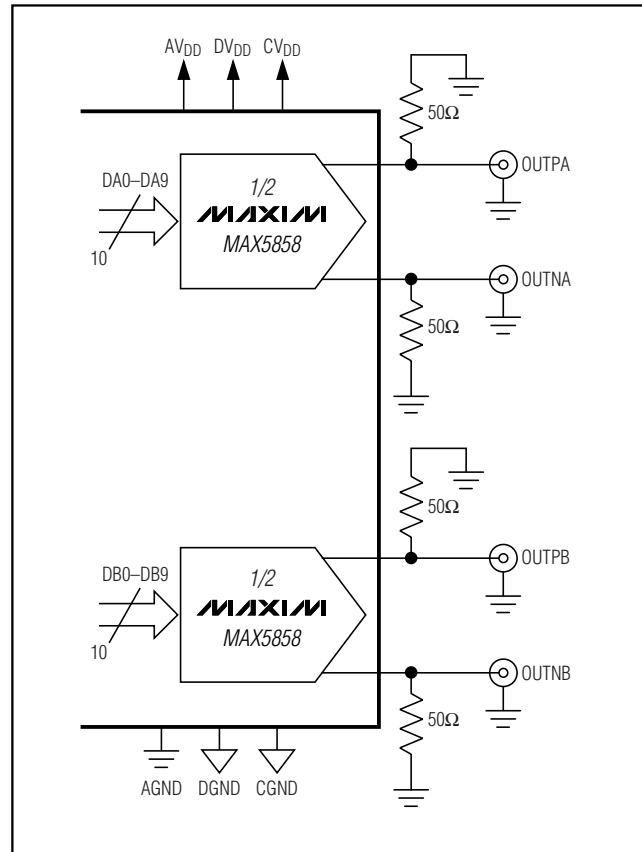

Figure 9. Application with DC-Coupled Differential Outputs

Differential DC-Coupled Configuration

Figure 9 shows the MAX5858 output operating in differential, DC-coupled mode. This configuration can be used in communication systems employing analog quadrature upconverters and requiring a baseband sampling, dual-channel, high-speed DAC for I/Q synthesis. In these applications, information bandwidth can extend from 10MHz down to several hundred kilohertz. DC-coupling is desirable in order to eliminate long discharge time constants that are problematic with large, expensive coupling capacitors. Analog quadrature upconverters have a DC common-mode input requirement of typically 0.7V to 1.0V. The MAX5858 differential I/Q outputs can maintain the desired full-scale frequency spectrum at the required 0.7V to 1.0V DC common-mode level when powered from a single 2.85V ($\pm 5\%$) supply. The MAX5858 meets this low-power requirement with minimal reduction in dynamic range while eliminating the need for level-shifting resistor networks.

Power Supplies, Bypassing, Decoupling, and Layout

Grounding and power-supply decoupling strongly influence the MAX5858 performance. Unwanted digital crosstalk can couple through the input, reference, power-supply, and ground connections, which can affect dynamic specifications, like signal-to-noise ratio or spurious-free dynamic range. In addition, electromagnetic interference (EMI) can either couple into or be generated by the MAX5858. Observe the grounding and power-supply decoupling guidelines for high-speed, high-frequency applications. Follow the power supply and filter configuration to realize optimum dynamic performance.

Use of a multilayer printed circuit (PC) board with separate ground and power-supply planes is recommended. Run high-speed signals on lines directly above the ground plane. The MAX5858 has separate analog and digital ground buses (AGND, CGND, and DGND,

Dual, 10-Bit, 300Msps, Current-Output DAC with 4x/2x/1x Interpolation Filters

respectively). Provide separate analog, digital, and clock ground sections on the PC board with only one point connecting the three planes. The ground connection points should be located underneath the device and connected to the exposed paddle. Run digital signals above the digital ground plane and analog/clock signals above the analog/clock ground plane. Digital signals should be kept away from sensitive analog, clock, and reference inputs. Keep digital signal paths short and metal trace lengths matched to avoid propagation delay and data skew mismatch.

The MAX5858 includes three separate power-supply inputs: analog (AV_{DD}), digital (DV_{DD}), and clock (CV_{DD}). Use a single linear regulator power source to branch out to three separate power-supply lines (AV_{DD}, DV_{DD}, CV_{DD}) and returns (AGND, DGND, CGND). Filter each power-supply line to the respective return line using LC filters comprising ferrite beads and 10µF capacitors. Filter each supply input locally with 0.1µF ceramic capacitors to the respective return lines.

Note: To maintain the dynamic performance of the Electrical Characteristics, ensure the voltage difference between DV_{DD}, AV_{DD}, and CV_{DD} does not exceed 150mV.

Thermal Characteristics and Packaging

Thermal Resistance

48-lead TQFP-EP:

$$\theta_{JA} = 37^{\circ}\text{C/W}$$

Keep the device junction temperature below +125°C to meet specified electrical performance. Lower the power-supply voltage to maintain specified performance when the DAC update rate approaches 300Msps and the ambient temperature equals +85°C.

The MAX5858 is packaged in a 48-pin TQFP-EP package, providing greater design flexibility, increased thermal efficiency, and optimized AC performance of the DAC. The EP enables the implementation of grounding techniques, which are necessary to ensure highest performance operation.

In this package, the data converter die is attached to an EP leadframe with the back of this frame exposed at the package bottom surface, facing the PC board side of the package. This allows a solid attachment of the package to the PC board with standard infrared (IR)-flow soldering techniques. A specially created land pattern on the PC board, matching the size of the EP (5mm × 5mm), ensures the proper attachment and grounding of the DAC. Designing vias* into the land area and

implementing large ground planes in the PC board design will allow for highest performance operation of the DAC. Use an array of 3 × 3 (or greater) vias (≤0.3mm diameter per via hole and 1.2mm pitch between via holes) for this 48-pin TQFP-EP package.

Dynamic Performance Parameter Definitions

Adjacent Channel Leakage Ratio (ACLR)

Commonly used in combination with wideband code-division multiple-access (WCDMA), ACLR reflects the leakage power ratio in dB between the measured power within a channel relative to its adjacent channel. ACLR provides a quantifiable method of determining out-of-band spectral energy and its influence on an adjacent channel when a bandwidth-limited RF signal passes through a nonlinear device.

Total Harmonic Distortion (THD)

THD is the ratio of the RMS sum of all essential harmonics (within a Nyquist window) of the input signal to the fundamental itself. This can be expressed as:

$$\text{THD} = 20 \times \log \left(\frac{\sqrt{V_2^2 + V_3^2 + V_4^2 + \dots + V_N^2}}{V_1} \right)$$

where V₁ is the fundamental amplitude, and V₂ through V_N are the amplitudes of the 2nd through Nth order harmonics.

Spurious-Free Dynamic Range (SFDR)

SFDR is the ratio of RMS amplitude of the carrier frequency (maximum signal component) to the RMS value of their next-largest spectral component. SFDR is usually measured in dBc with respect to the carrier frequency amplitude or in dB FS with respect to the DAC's full-scale range. Depending on its test condition, SFDR is observed within a predefined window or to Nyquist.

Multitone Power Ratio (MTPR)

A series of equally spaced tones are applied to the DAC with one tone removed from the center of the range. MTPR is defined as the worst-case distortion (usually a 3rd-order harmonic product of the fundamental frequencies), which appears as the largest spur at the frequency of the missing tone in the sequence. This test can be performed with any number of input tones; however, four and eight tones are among the most common test conditions for CDMA- and GSM/EDGE-type applications.

*Vias connect the land pattern to internal or external copper planes.

Dual, 10-Bit, 300MSPS, Current-Output DAC with 4x/2x/1x Interpolation Filters

Intermodulation Distortion (IMD)

The two-tone IMD is the ratio expressed in dBc of either output tone to the worst 3rd-order (or higher) IMD products.

Static Performance Parameter Definitions

Integral Nonlinearity (INL)

Integral nonlinearity (INL) is the deviation of the values on an actual transfer function from a line drawn between the end points of the transfer function, once offset and gain errors have been nullified. For a DAC, the deviations are measured at every individual step.

Differential Nonlinearity (DNL)

Differential nonlinearity (DNL) is the difference between an actual step height and the ideal value of 1 LSB. A DNL error specification no more negative than -1 LSB guarantees monotonic transfer function.

Offset Error

Offset error is the current flowing from positive DAC output when the digital input code is set to zero. Offset error is expressed in LSBs.

Gain Error

A gain error is the difference between the ideal and the actual full-scale output current on the transfer curve, after nullifying the offset error. This error alters the slope of the transfer function and corresponds to the same percentage error in each step. The ideal current is defined by reference voltage at $V_{REF0} / I_{REF} \times 32$.

Settling Time

The settling time is the amount of time required from the start of a transition until the DAC output settles to its new output value to within the converter's specified accuracy.

Glitch Impulse

A glitch is generated when a DAC switches between two codes. The largest glitch is usually generated around the midscale transition, when the input pattern transitions from 011...111 to 100...000. This occurs due to timing variations between the bits. The glitch impulse is found by integrating the voltage of the glitch at the midscale transition over time. The glitch impulse is usually specified in pV-s.

Chip Information

TRANSISTOR COUNT: 178,376

PROCESS: CMOS

Dual, 10-Bit, 300MSPS, Current-Output DAC with 4x/2x/1x Interpolation Filters

Package Information

(The package drawing(s) in this data sheet may not reflect the most current specifications. For the latest package outline information, go to www.maxim-ic.com/packages.)

MAX5858

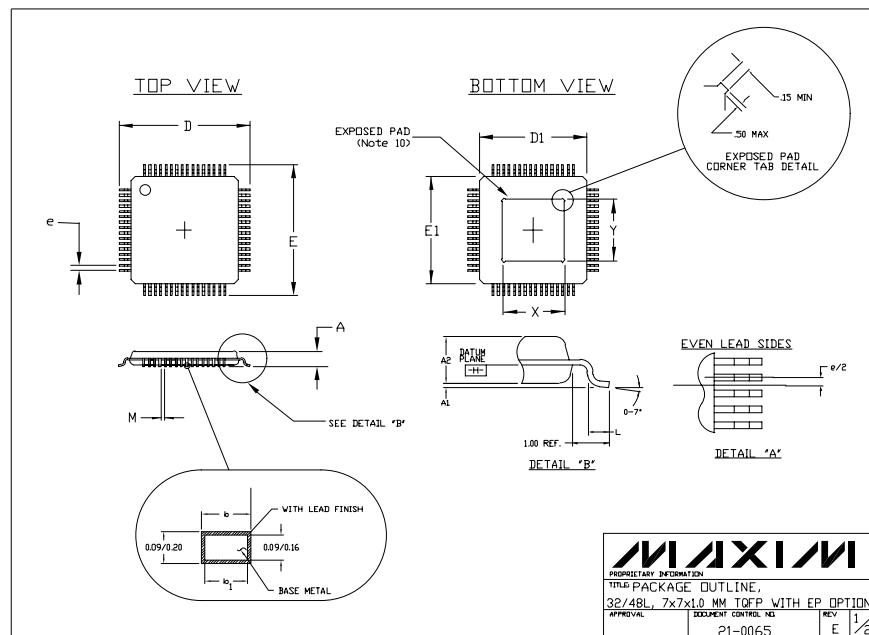

- NOTES:
1. ALL DIMENSIONS AND TOLERANCING CONFORM TO ANSI Y14.5-1982.
 2. DATUM PLANE [A] IS LOCATED AT MOLD PARTING LINE AND COINCIDENT WITH LEAD, WHERE LEAD EXITS PLASTIC BODY AT BOTTOM OF PARTING LINE.
 3. DIMENSIONS D1 AND E1 DO NOT INCLUDE MOLD PROTRUSION. ALLOWABLE MOLD PROTRUSION IS 0.254 MM ON D1 AND E1 DIMENSIONS.
 4. THE TOP OF PACKAGE IS SMALLER THAN THE BOTTOM OF PACKAGE BY 0.15 MILLIMETERS.
 5. DIMENSION b DOES NOT INCLUDE DAMBAR PROTRUSION. ALLOWABLE DAMBAR PROTRUSION SHALL BE 0.08 MM TOTAL IN EXCESS OF THE b DIMENSION AT MAXIMUM MATERIAL CONDITION.
 6. CONTROLLING DIMENSION: MILLIMETER.
 7. THIS OUTLINE CONFORMS TO JEDEC PUBLICATION 95 REGISTRATION MO-136, VARIATIONS AC AND AE.
 8. LEADS SHALL BE COPLANAR WITHIN .004 INCH.
 9. EXPOSED DIE PAD SHALL BE COPLANAR WITH BOTTOM OF PACKAGE WITHIN 2 MILS (.05 MM).
 10. DIMENSIONS X & Y APPLY TO EXPOSED PAD (EP) VERSIONS ONLY. SEE INDIVIDUAL PRODUCT DATASHEET TO DETERMINE IF A PRODUCT USES EXPOSED PAD PACKAGE.

SYMBOL	JEDEC VARIATION					
	ALL DIMENSIONS IN MILLIMETERS					
	AC			AE		
	MIN.	NOM.	MAX.	MIN.	NOM.	MAX.
A	~	~	1.20	~	~	1.20
A1	0.05	0.10	0.15	0.05	0.10	0.15
A2	0.95	1.00	1.05	0.95	1.00	1.05
D	9.00 BSC.			9.00 BSC.		
D1	7.00 BSC.			7.00 BSC.		
E	9.00 BSC.			9.00 BSC.		
E1	7.00 BSC.			7.00 BSC.		
L	0.45	0.60	0.75	0.45	0.60	0.75
M	0.15	~	~	0.14	~	~
N	32			48		
e	0.80 BSC.			0.50 BSC.		
b	0.30	0.37	0.45	0.17	0.22	0.27
b1	0.30	0.35	0.40	0.17	0.20	0.23
*X	3.20	3.50	3.80	3.70	4.00	4.30
*Y	3.20	3.50	3.80	3.70	4.00	4.30

* EXPOSED PAD (Note 10)

Maxim cannot assume responsibility for use of any circuitry other than circuitry entirely embodied in a Maxim product. No circuit patent licenses are implied. Maxim reserves the right to change the circuitry and specifications without notice at any time.

Maxim Integrated Products, 120 San Gabriel Drive, Sunnyvale, CA 94086 408-737-7600 23