

TOSHIBA CMOS Digital Integrated Circuit Silicon Monolithic

TC74AC161P, TC74AC161F, TC74AC161FN, TC74AC161FT TC74AC163P, TC74AC163F, TC74AC163FN, TC74AC163FT

Synchronous Presetable 4-Bit Binary Counter

TC74AC161P/F/FN/FT Asynchronous Clear

TC74AC163P/F/FN/FT Synchronous Clear

The TC74AC161 and 163 are advanced high speed CMOS SYNCHRONOUS PRESETTABLE COUNTERs fabricated with silicon gate and double-layer metal wiring C²MOS technology.

They achieve the high speed operation similar to equivalent Bipolar Schottky TTL while maintaining the CMOS low power dissipation.

The CK input is active on the rising edge. Both $\overline{\text{LOAD}}$ and $\overline{\text{CLR}}$ inputs are active on low logic level.

Presetting of these IC's is synchronous to the rising edge of CK.

The clear function of the TC74AC163 is synchronous to CK, while the TC74AC161 are cleared asynchronously.

Two enable inputs (ENP and ENT) and CARRY OUTPUT are provided to enable easy cascading of counters, which facilitates easy implementation of n-bit counters without using external gates.

All inputs are equipped with protection circuits against static discharge or transient excess voltage.

Features

- High speed: $f_{\text{max}} = 170 \text{ MHz (typ.)}$ at $V_{\text{CC}} = 5 \text{ V}$
- Low power dissipation: $I_{\text{CC}} = 8 \mu\text{A (max)}$ at $T_a = 25^\circ\text{C}$
- High noise immunity: $V_{\text{NIH}} = V_{\text{NIL}} = 28\% V_{\text{CC (min)}}$
- Symmetrical output impedance: $|I_{\text{OH}}| = I_{\text{OL}} = 24 \text{ mA (min)}$
Capability of driving 50Ω transmission lines.
- Balanced propagation delays: $t_{\text{pLH}} \approx t_{\text{pHL}}$
- Wide operating voltage range: $V_{\text{CC (opr)}} = 2 \text{ to } 5.5 \text{ V}$
- Pin and function compatible with 74F161/163

Note: xxxFN (JEDEC SOP) is not available in Japan.

TC74AC161P, TC74AC163P

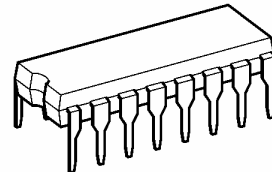

DIP16-P-300-2.54A

TC74AC161F, TC74AC163F

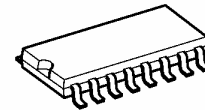

SOP16-P-300-1.27A

TC74AC161FN, TC74AC163FN

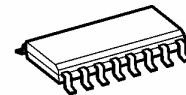

SOL16-P-150-1.27

TC74AC161FT, TC74AC163FT

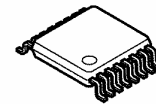

TSSOP16-P-0044-0.65A

Weight

DIP16-P-300-2.54A	: 1.00 g (typ.)
SOP16-P-300-1.27A	: 0.18 g (typ.)
SOL16-P-150-1.27	: 0.13 g (typ.)
TSSOP16-P-0044-0.65A	: 0.06 g (typ.)

Pin Assignment

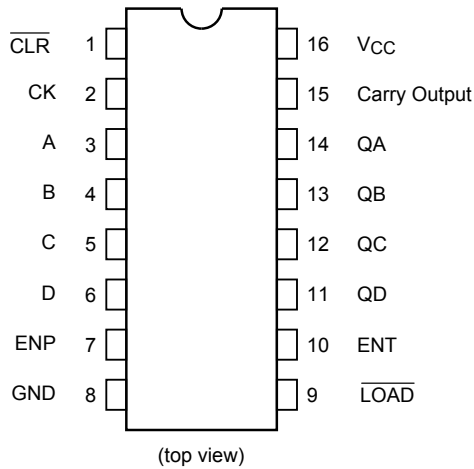

IEC Logic Symbol

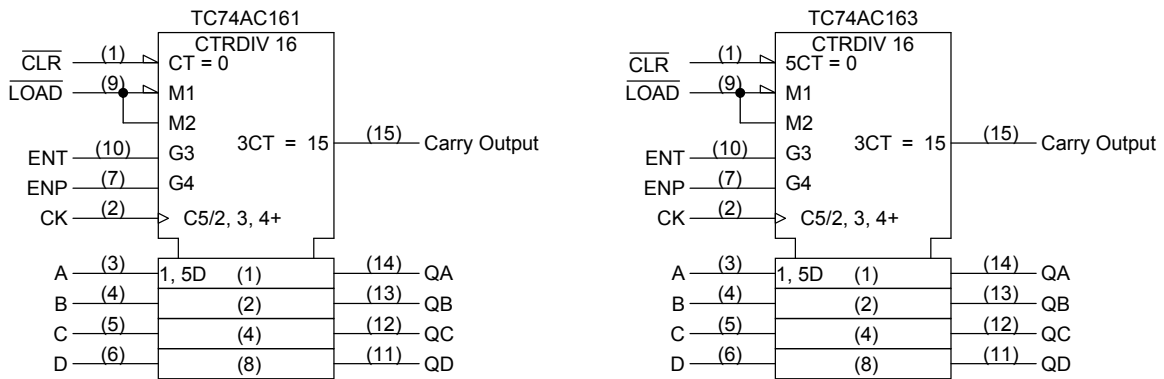

Truth Table (Note)

Inputs							Outputs				Function
CLR (161)	CLR (163)	LOAD	ENP	ENT	CK (161)	CK (163)	QA	QB	QC	QD	
L	L	X	X	X	X	\uparrow	L	L	L	L	Reset to "0"
H	H	L	X	X	\uparrow	\uparrow	A	B	C	D	Preset Data
H	H	H	X	L	\uparrow	\uparrow	No Change				No Count
H	H	H	L	X	\uparrow	\uparrow	No Change				No Count
H	H	H	H	H	\uparrow	\uparrow	Count Up				Count
H	X	X	X	X	\downarrow	\downarrow	No Change				No Count

Note: X: Don't care

A, B, C, D: Logic level of data inputs

Carry: Carry = ENT·QA·QB·QC·QD

Timing Chart

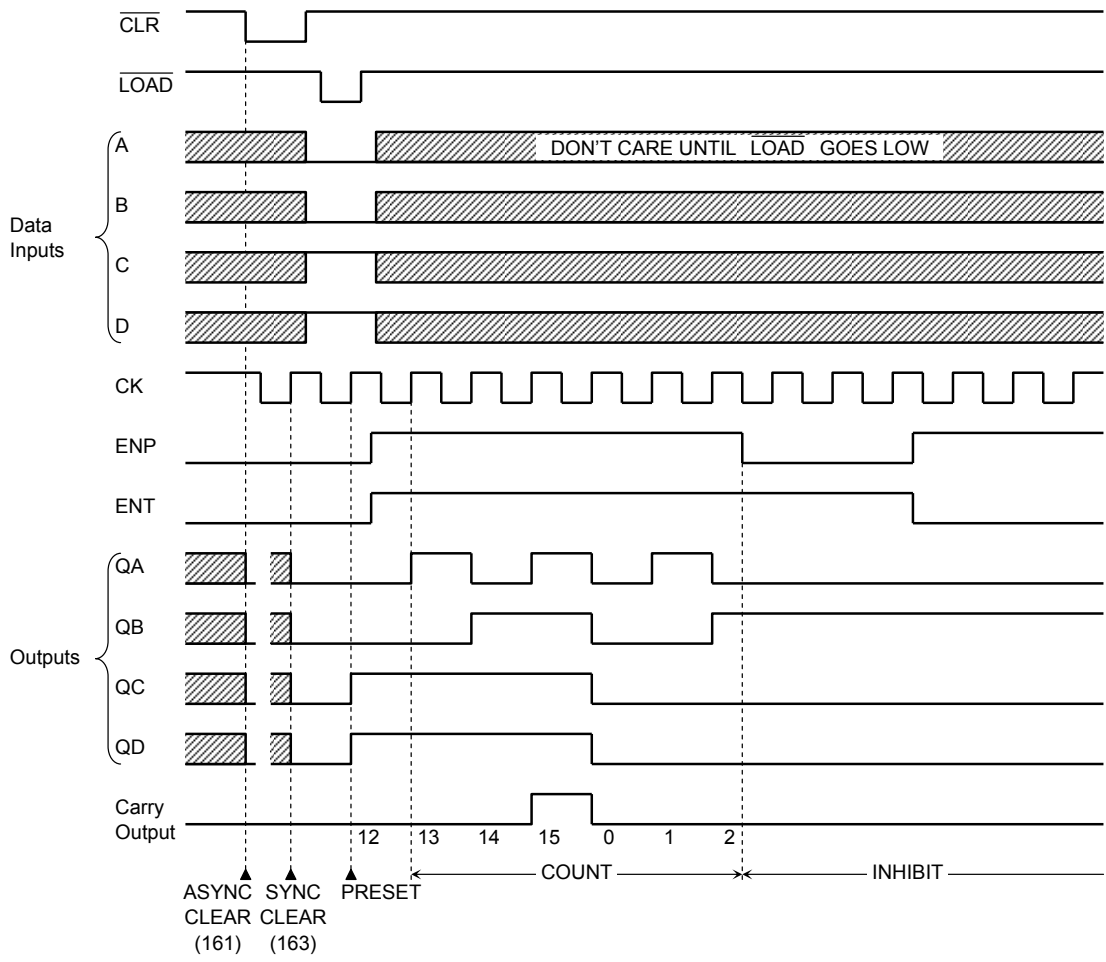

System Diagram

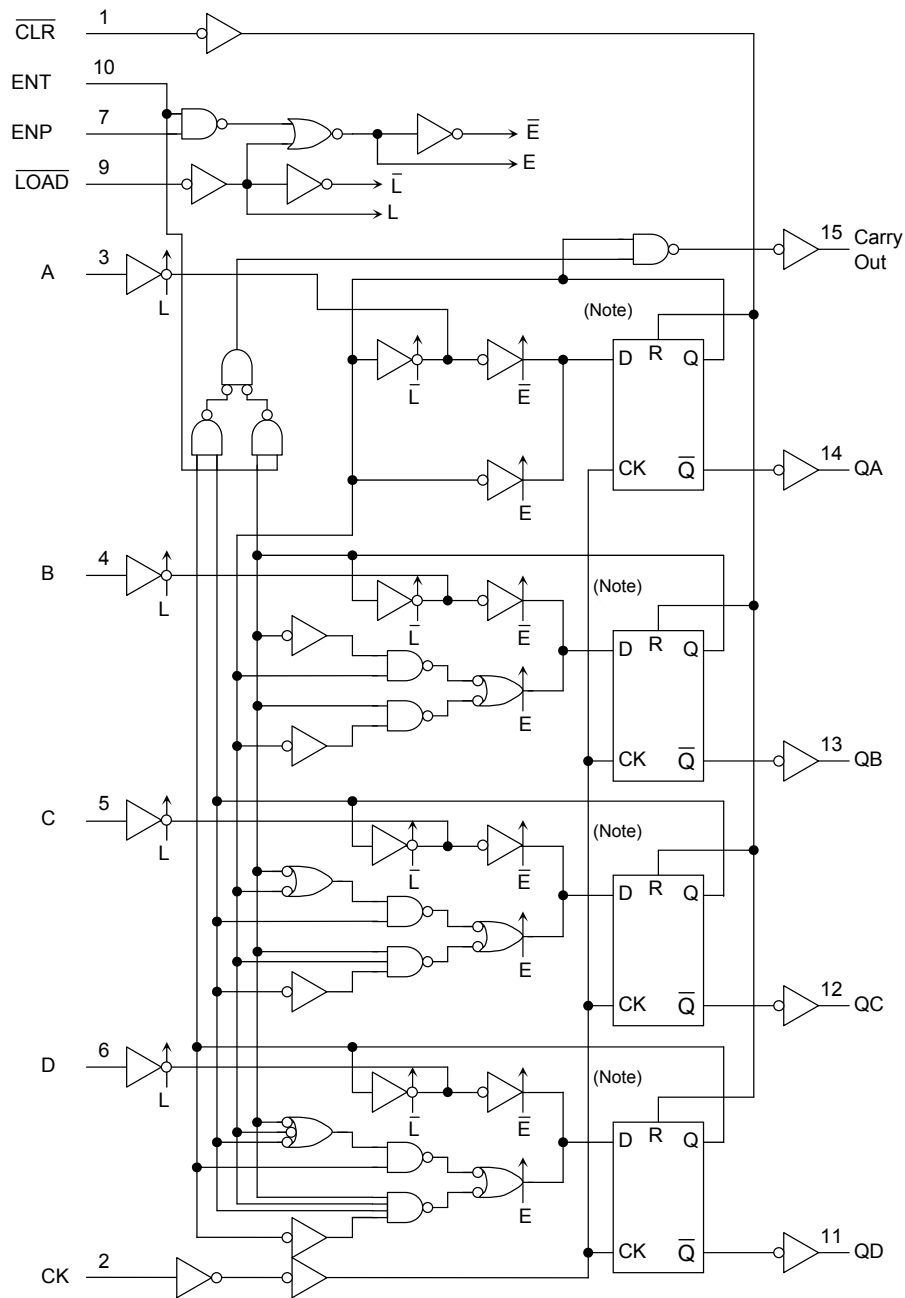

Note: Truth table of internal F/F

TC74AC161					TC74AC163				
D	CK	R	Q	\bar{Q}	D	CK	R	Q	\bar{Q}
X	X	H	L	H	X	\uparrow	H	L	H
L	\uparrow	L	L	H	L	\uparrow	L	L	H
H	\uparrow	L	H	L	H	\uparrow	L	H	L
X	\downarrow	L	No Change		X	\downarrow	L	No Change	

X: Don't care

Absolute Maximum Ratings (Note 1)

Characteristics	Symbol	Rating	Unit
Supply voltage range	V_{CC}	-0.5 to 7.0	V
DC input voltage	V_{IN}	-0.5 to $V_{CC} + 0.5$	V
DC output voltage	V_{OUT}	-0.5 to $V_{CC} + 0.5$	V
Input diode current	I_{IK}	± 20	mA
Output diode current	I_{OK}	± 50	mA
DC output current	I_{OUT}	± 50	mA
DC V_{CC} /ground current	I_{CC}	± 125	mA
Power dissipation	P_D	500 (DIP) (Note 2)/180 (SOP/TSSOP)	mW
Storage temperature	T_{stg}	-65 to 150	$^{\circ}C$

Note 1: Exceeding any of the absolute maximum ratings, even briefly, lead to deterioration in IC performance or even destruction.

Using continuously under heavy loads (e.g. the application of high temperature/current/voltage and the significant change in temperature, etc.) may cause this product to decrease in the reliability significantly even if the operating conditions (i.e. operating temperature/current/voltage, etc.) are within the absolute maximum ratings and the operating ranges.

Please design the appropriate reliability upon reviewing the Toshiba Semiconductor Reliability Handbook ("Handling Precautions"/Derating Concept and Methods) and individual reliability data (i.e. reliability test report and estimated failure rate, etc).

Note 2: 500 mW in the range of $T_a = -40$ to $65^{\circ}C$. From $T_a = 65$ to $85^{\circ}C$ a derating factor of -10 mW/ $^{\circ}C$ should be applied up to 300 mW.

Operating Ranges (Note)

Characteristics	Symbol	Rating	Unit
Supply voltage	V_{CC}	2.0 to 5.5	V
Input voltage	V_{IN}	0 to V_{CC}	V
Output voltage	V_{OUT}	0 to V_{CC}	V
Operating temperature	T_{opr}	-40 to 85	$^{\circ}C$
Input rise and fall time	dt/dV	0 to 100 ($V_{CC} = 3.3 \pm 0.3$ V) 0 to 20 ($V_{CC} = 5 \pm 0.5$ V)	ns/V

Note: The operating ranges must be maintained to ensure the normal operation of the device. Unused inputs must be tied to either VCC or GND.

Electrical Characteristics

DC Characteristics

Characteristics	Symbol	Test Condition	V _{CC} (V)	Ta = 25°C			Ta = -40 to 85°C		Unit	
				Min	Typ.	Max	Min	Max		
High-level input voltage	V _{IH}	—	2.0	1.50	—	—	1.50	—	V	
			3.0	2.10	—	—	2.10	—		
			5.5	3.85	—	—	3.85	—		
Low-level input voltage	V _{IL}	—	2.0	—	—	0.50	—	0.50	V	
			3.0	—	—	0.90	—	0.90		
			5.5	—	—	1.65	—	1.65		
High-level output voltage	V _{OH}	V _{IN} = V _{IH} or V _{IL}	I _{OH} = -50 μA	2.0	1.9	2.0	—	1.9	—	V
				3.0	2.9	3.0	—	2.9	—	
				4.5	4.4	4.5	—	4.4	—	
			I _{OH} = -4 mA	3.0	2.58	—	—	2.48	—	
				4.5	3.94	—	—	3.80	—	
I _{OH} = -75 mA (Note)	5.5	—	—	—	3.85	—				
Low-level output voltage	V _{OL}	V _{IN} = V _{IH} or V _{IL}	I _{OL} = 50 μA	2.0	—	0.0	0.1	—	0.1	V
				3.0	—	0.0	0.1	—	0.1	
				4.5	—	0.0	0.1	—	0.1	
			I _{OL} = 12 mA	3.0	—	—	0.36	—	0.44	
				4.5	—	—	0.36	—	0.44	
I _{OL} = 75 mA (Note)	5.5	—	—	—	—	1.65				
Input leakage current	I _{IN}	V _{IN} = V _{CC} or GND	5.5	—	—	±0.1	—	±1.0	μA	
Quiescent supply current	I _{CC}	V _{IN} = V _{CC} or GND	5.5	—	—	8.0	—	80.0	μA	

Note: This spec indicates the capability of driving 50 Ω transmission lines.

One output should be tested at a time for a 10 ms maximum duration.

Timing Requirements (input: $t_r = t_f = 3 \text{ ns}$)

Characteristics	Symbol	Test Condition	V _{CC} (V)	T _a = 25°C	T _a = -40 to 85°C	Unit
				Limit	Limit	
Minimum pulse width (CK)	$t_w(L)$	Figure 1	3.3 ± 0.3	7.0	7.0	ns
	$t_w(H)$		5.0 ± 0.5	5.0	5.0	
Minimum pulse width (\overline{CLR}) (Note 1)	$t_w(L)$	Figure 4	3.3 ± 0.3 5.0 ± 0.5	7.0 5.0	7.0 5.0	ns
Minimum set-up time (\overline{LOAD} , ENP, ENT)	t_s	Figure 2, Figure 3	3.3 ± 0.3	11.0	13.0	ns
			5.0 ± 0.5	7.0	7.0	
Minimum set-up time (A, B, C, D)	t_s	Figure 2	3.3 ± 0.3	8.0	8.0	ns
			5.0 ± 0.5	4.0	4.0	
Minimum set-up time (\overline{CLR}) (Note 2)	t_s	Figure 5	3.3 ± 0.3	6.0	6.0	ns
			5.0 ± 0.5	4.0	4.0	
Minimum hold time	t_h	Figure 2, Figure 3, Figure 5	3.3 ± 0.3	1.0	1.0	ns
			5.0 ± 0.5	1.0	1.0	
Minimum removal time (\overline{CLR}) (Note 1)	t_{rem}	Figure 4	3.3 ± 0.3	6.0	6.0	ns
			5.0 ± 0.5	4.0	4.0	

Note 1: For TC74AC161 only

Note 2: For TC74AC163 only

AC Characteristics (C_L = 50 pF, R_L = 500 Ω, input: t_r = t_f = 3 ns)

Characteristics	Symbol	Test Condition	V _{CC} (V)	Ta = 25°C			Ta = -40 to 85°C		Unit
				Min	Typ.	Max	Min	Max	
Propagation delay time (CK-Q)	t _{pLH}	Figure 1	3.3 ± 0.3	—	8.8	15.8	1.0	18.0	ns
	t _{pHL}		5.0 ± 0.5	—	6.5	9.6	1.0	11.0	
Propagation delay time (CK-carry, count mode)	t _{pLH}	Figure 1	3.3 ± 0.3	—	10.4	18.4	1.0	21.6	ns
	t _{pHL}		5.0 ± 0.5	—	8.1	11.8	1.0	13.5	
Propagation delay time (CK-carry, preset mode)	t _{pLH}	Figure 2	3.3 ± 0.3	—	12.9	22.4	1.0	25.5	ns
	t _{pHL}		5.0 ± 0.5	—	9.1	13.2	1.0	15.0	
Propagation delay time (ENT-carry)	t _{pLH}	Figure 6	3.3 ± 0.3	—	7.5	13.2	1.0	15.0	ns
	t _{pHL}		5.0 ± 0.5	—	5.8	8.3	1.0	9.5	
Propagation delay time ($\overline{\text{CLR}}$ -Q) (Note 1)	t _{pHL}	Figure 4	3.3 ± 0.3	—	10.6	18.4	1.0	21.0	ns
			5.0 ± 0.5	—	7.7	11.4	1.0	13.0	
Propagation delay time ($\overline{\text{CLR}}$ -carry) (Note 1)	t _{pHL}	Figure 4	3.3 ± 0.3	—	12.0	21.0	1.0	24.0	ns
			5.0 ± 0.5	—	8.6	12.7	1.0	14.5	
Maximum clock frequency	f _{max}	—	3.3 ± 0.3	50	110	—	50	—	MHz
			5.0 ± 0.5	90	140	—	90	—	
Input capacitance	C _{IN}	—	—	5	10	—	10	pF	
Power dissipation capacitance	C _{PD}	(Note 2)	—	85	—	—	—	pF	

Note 1: For TC74AC161 only

Note 2: C_{PD} is defined as the value of the internal equivalent capacitance which is calculated from the operating current consumption without load.

Average operating current can be obtained by the equation:

$$I_{CC (opr)} = C_{PD} \cdot V_{CC} \cdot f_{IN} + I_{CC}$$

When the outputs drive a capacitive load, total current consumption is the sum of C_{PD}, and ΔI_{CC} which is obtained from the following formula:

$$\Delta I_{CC} = f_{CK} \cdot V_{CC} \left(\frac{C_{QA}}{2} + \frac{C_{QB}}{4} + \frac{C_{QC}}{8} + \frac{C_{QD}}{16} + \frac{C_{CO}}{16} \right)$$

C_{QA} to C_{QD} and C_{CO} are the capacitances at QA to QD and CARRY OUT, respectively.

f_{CK} is the input frequency of the CK.

Switching Characteristics Test Waveform

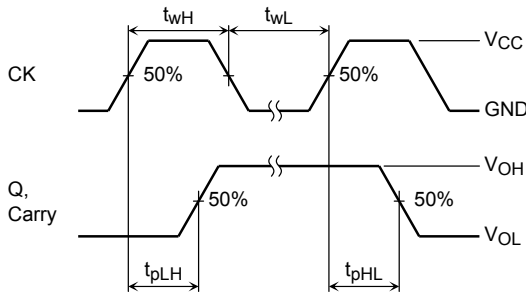

Figure 1 Count Mode

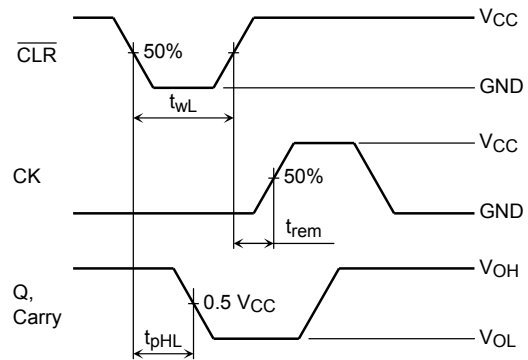

Figure 4 Clear Mode (TC74AC161)

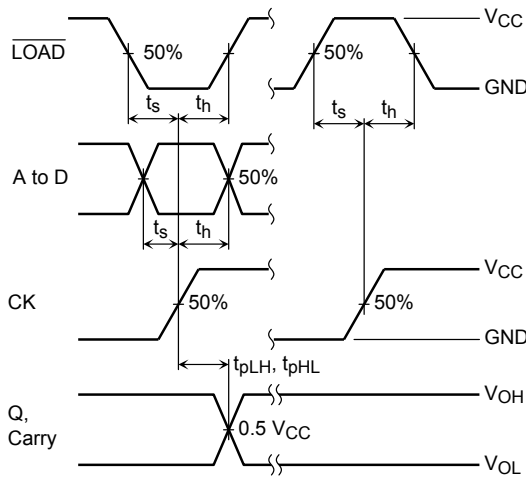

Figure 2 Preset Mode

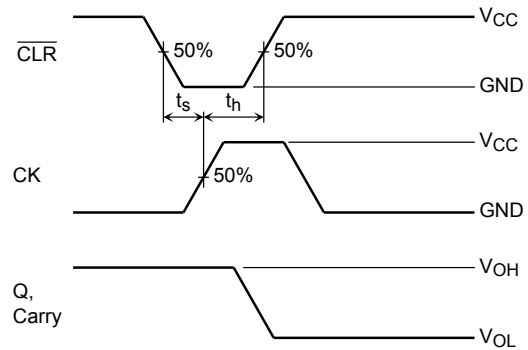

Figure 5 Clear Mode (TC74AC163)

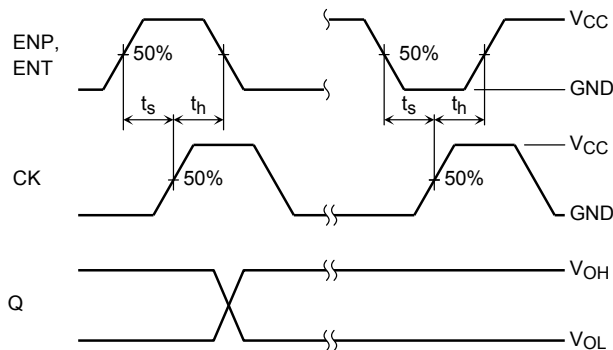

Figure 3 Count Enable Mode

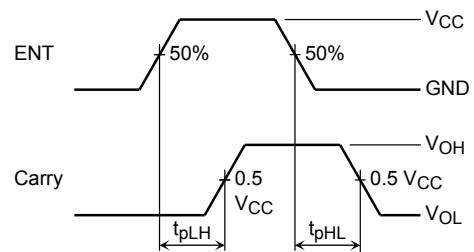
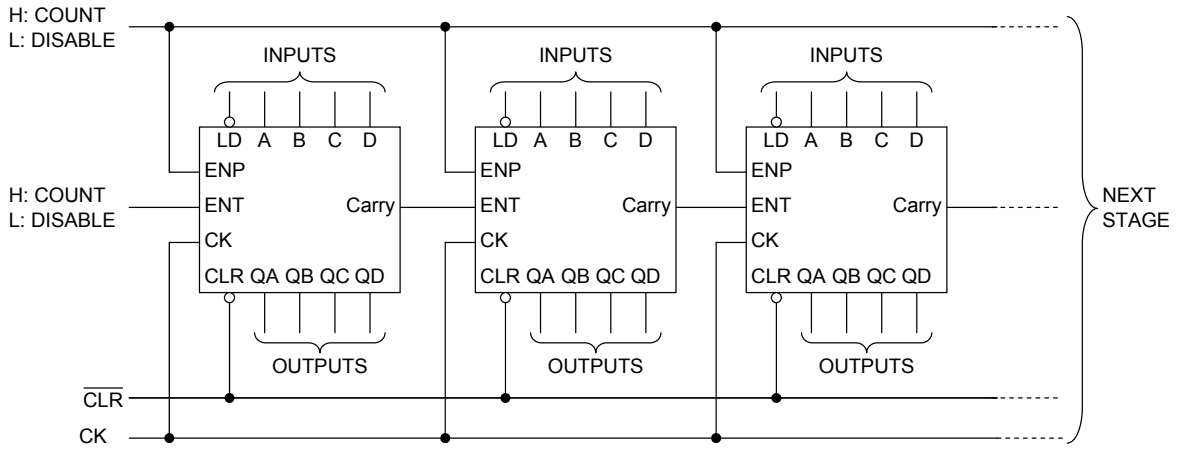

Figure 6 Cascade Mode (fix maximum count)

Typical Application

Parallel Carry N-Bit Counter



Package Dimensions

DIP16-P-300-2.54A

Unit : mm

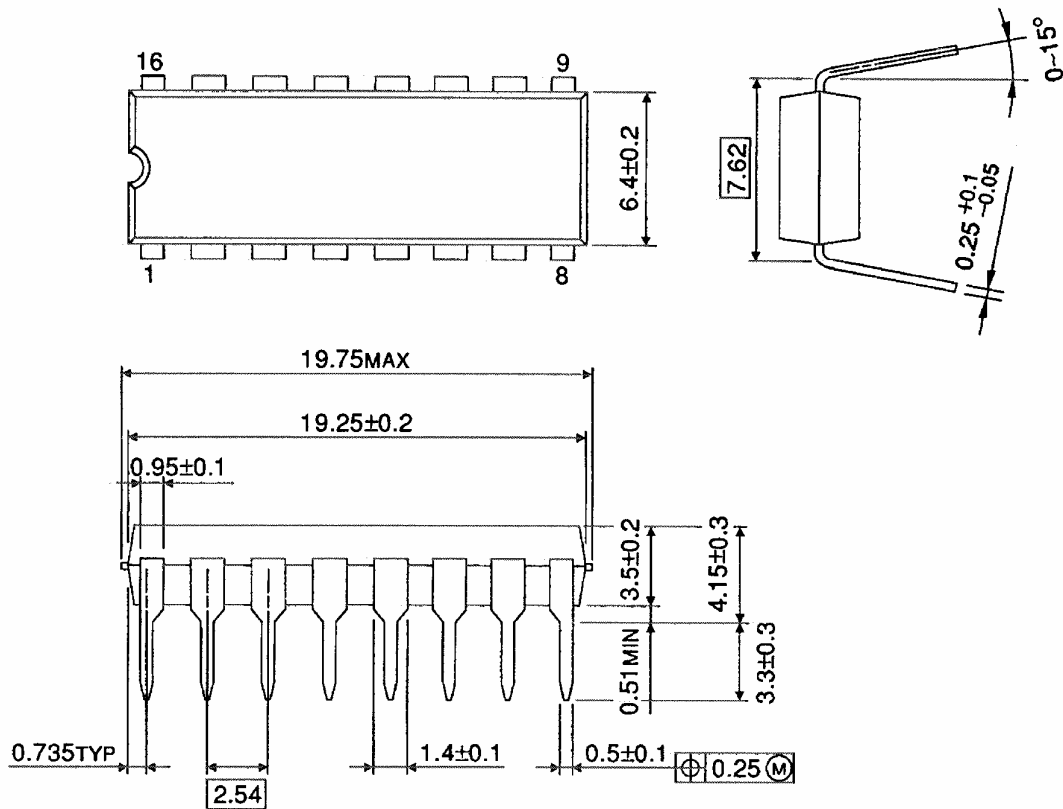

Weight: 1.00 g (typ.)

Package Dimensions

SOP16-P-300-1.27A

Unit: mm

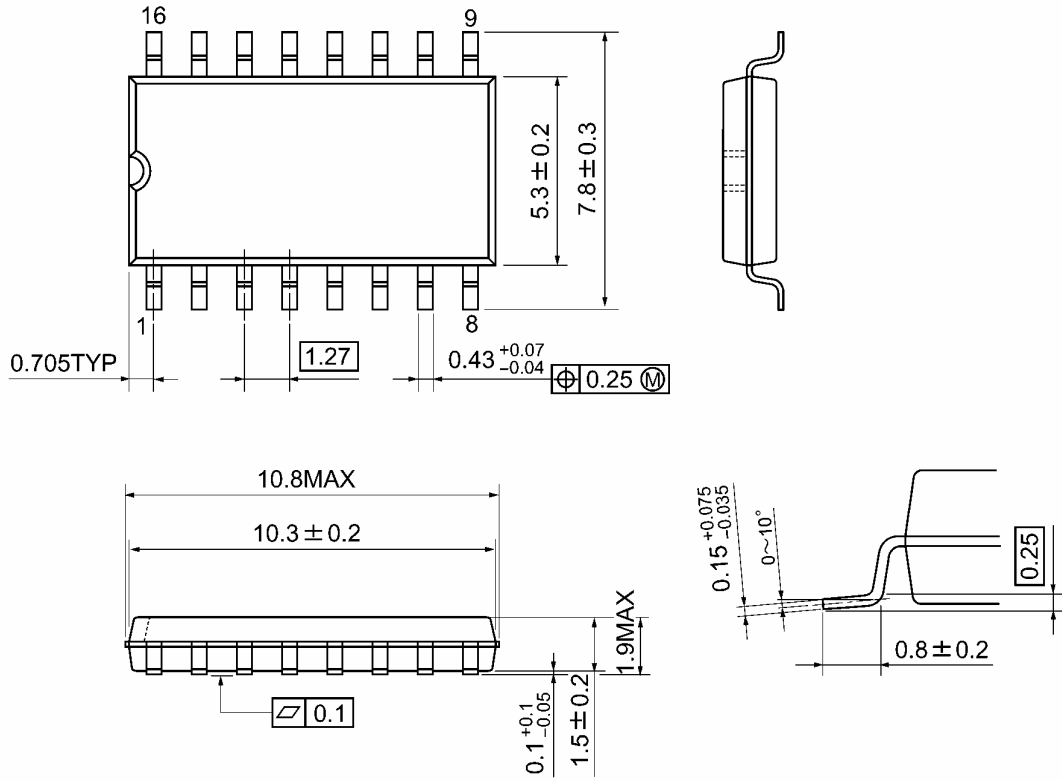

Weight: 0.18 g (typ.)

Package Dimensions (Note)

SOL16-P-150-1.27

Unit : mm

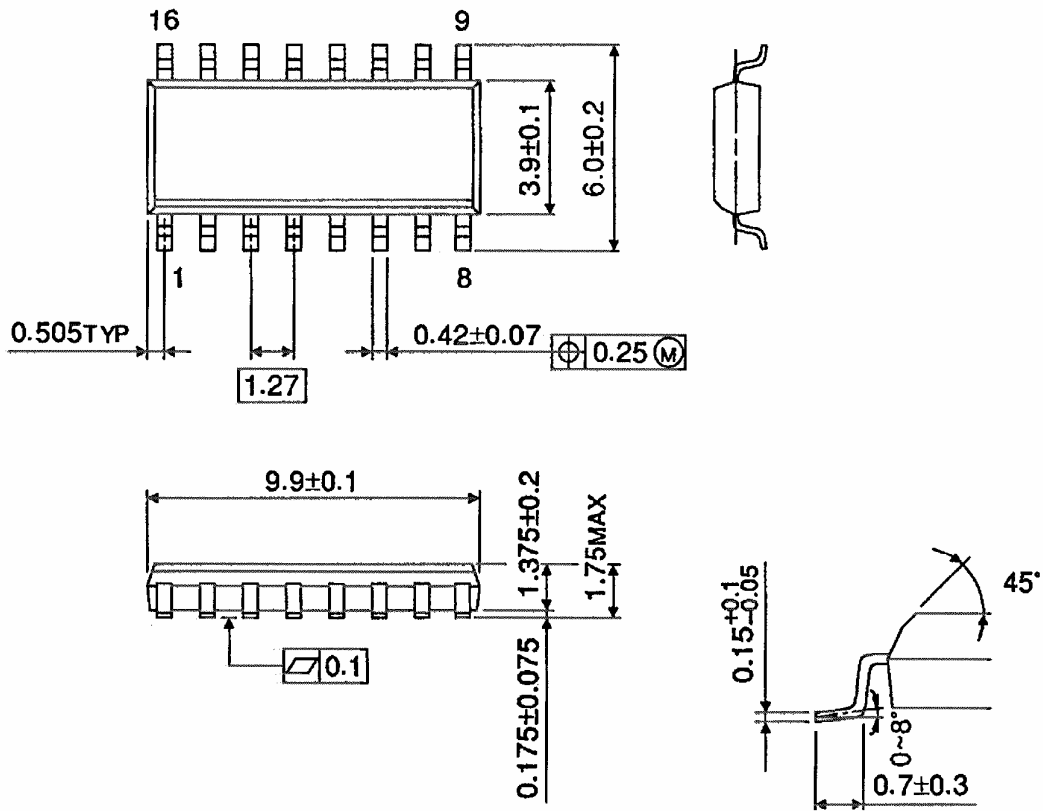

Note: This package is not available in Japan.

Weight: 0.13 g (typ.)

Package Dimensions

TSSOP16-P-0044-0.65A

Unit: mm

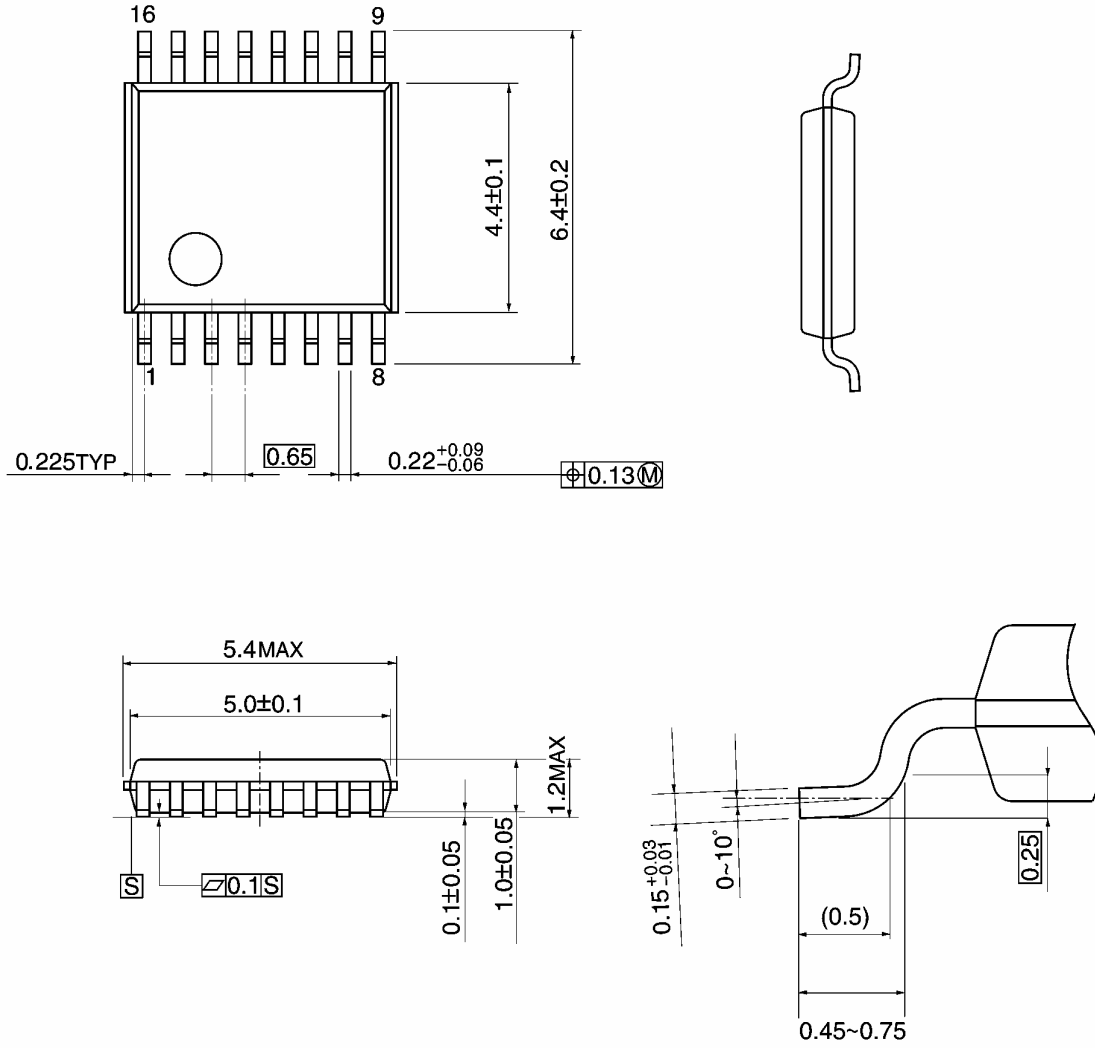

Weight: 0.06 g (typ.)

RESTRICTIONS ON PRODUCT USE

20070701-EN GENERAL

- The information contained herein is subject to change without notice.
- TOSHIBA is continually working to improve the quality and reliability of its products. Nevertheless, semiconductor devices in general can malfunction or fail due to their inherent electrical sensitivity and vulnerability to physical stress. It is the responsibility of the buyer, when utilizing TOSHIBA products, to comply with the standards of safety in making a safe design for the entire system, and to avoid situations in which a malfunction or failure of such TOSHIBA products could cause loss of human life, bodily injury or damage to property.
In developing your designs, please ensure that TOSHIBA products are used within specified operating ranges as set forth in the most recent TOSHIBA products specifications. Also, please keep in mind the precautions and conditions set forth in the "Handling Guide for Semiconductor Devices," or "TOSHIBA Semiconductor Reliability Handbook" etc.
- The TOSHIBA products listed in this document are intended for usage in general electronics applications (computer, personal equipment, office equipment, measuring equipment, industrial robotics, domestic appliances, etc.). These TOSHIBA products are neither intended nor warranted for usage in equipment that requires extraordinarily high quality and/or reliability or a malfunction or failure of which may cause loss of human life or bodily injury ("Unintended Usage"). Unintended Usage include atomic energy control instruments, airplane or spaceship instruments, transportation instruments, traffic signal instruments, combustion control instruments, medical instruments, all types of safety devices, etc.. Unintended Usage of TOSHIBA products listed in this document shall be made at the customer's own risk.
- The products described in this document shall not be used or embedded to any downstream products of which manufacture, use and/or sale are prohibited under any applicable laws and regulations.
- The information contained herein is presented only as a guide for the applications of our products. No responsibility is assumed by TOSHIBA for any infringements of patents or other rights of the third parties which may result from its use. No license is granted by implication or otherwise under any patents or other rights of TOSHIBA or the third parties.
- Please contact your sales representative for product-by-product details in this document regarding RoHS compatibility. Please use these products in this document in compliance with all applicable laws and regulations that regulate the inclusion or use of controlled substances. Toshiba assumes no liability for damage or losses occurring as a result of noncompliance with applicable laws and regulations.