

**TC74VHC9541P,TC74VHC9541FT,TC74VHC9541FK**

Octal Universal Schmitt Buffer with 3-State Outputs

The TC74VHC9541 is an ultra-high-speed octal Schmitt buffer fabricated using silicon-gate CMOS technology. The TC74VHC9541 combines low power consumption of CMOS with Schottky TTL speeds.

The outputs can be put in the high-impedance state by placing a logic HIGH on the Enable ( $\bar{G}$ ) input. The CONT input determines the logical inversion of data. A logic LOW on the CONT input configures the TC74VHC9541 as an inverter; a logic HIGH on the CONT input configures the TC74VHC9541 as a buffer.

All the inputs have hysteresis between the positive-going and negative-going thresholds. Thus the TC74VHC9541 is capable of squaring up transitions of slowly changing input signals and provides an improved noise immunity.

Additionally, all the inputs have a newly developed protection circuit without a diode returned to  $V_{CC}$ . This enables the inputs to be tolerant of up to 5 volts even when power supply is down. The input power-down protection capability makes the TC74VHC9541 ideal for a wide range of applications, such as interfacing between different voltages, voltage translation from 5 V to 3 V and battery back-up circuits.

**Features**

- High speed:  $t_{pd} = 5.0 \text{ ns (typ.) (} V_{CC} = 5 \text{ V)}$
- Low supply current:  $I_{CC} = 4 \mu\text{A (max) (} T_a = 25^\circ\text{C)}$
- High noise immunity:  $V_{NIH} = V_{NIL} = 28\% V_{CC} \text{ (min)}$
- All inputs are provided with power-down protection.
- Symmetrical rise and fall delays:  $t_{pLH} \approx t_{pHL}$
- Wide operating voltage range:  $V_{CC} \text{ (opr)} = 2 \text{ to } 5.5 \text{ V}$
- Pin-compatible with TC74VHC540 and TC74VHC541

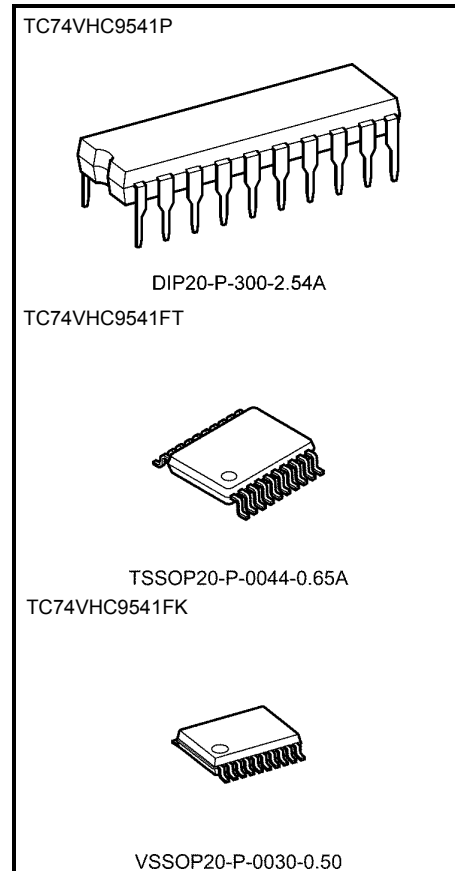

Weight

DIP20-P-300-2.54A:	1.30 g (typ.)
TSSOP20-P-0044-0.65A:	0.08 g (typ.)
VSSOP20-P-0030-0.50:	0.03 g (typ.)

## Pin Assignment

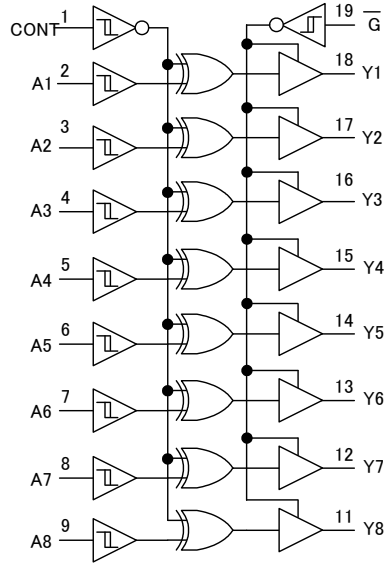
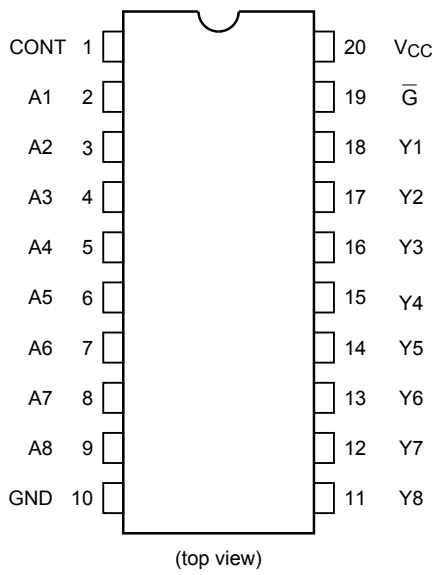

## Truth Table

Inputs			Outputs
$\bar{G}$	CONT	A <sub>n</sub>	Y <sub>n</sub>
H	X	X	Z
L	L	L	H
L	L	H	L
L	H	L	L
L	H	H	H

X: Don't care

Z: High impedance

## Absolute Maximum Ratings (Note)

Characteristics	Symbol	Rating	Unit
Supply voltage range	$V_{CC}$	-0.5 to 7.0	V
DC input voltage	$V_{IN}$	-0.5 to 7.0	V
DC output voltage	$V_{OUT}$	-0.5 to $V_{CC} + 0.5$	V
Input diode current	$I_{IK}$	-20	mA
Output diode current	$I_{OK}$	$\pm 20$	mA
DC output current	$I_{OUT}$	$\pm 25$	mA
DC $V_{CC}$ /ground current	$I_{CC}$	$\pm 75$	mA
Power dissipation	$P_D$	500 (DIP) (Note 2)/180(TSSOP/VSSOP)	mW
Storage temperature	$T_{stg}$	-65 to 150	$^{\circ}C$

Note 1: Exceeding any of the absolute maximum ratings, even briefly, lead to deterioration in IC performance or even destruction.

Using continuously under heavy loads (e.g. the application of high temperature/current/voltage and the significant change in temperature, etc.) may cause this product to decrease in the reliability significantly even if the operating conditions (i.e. operating temperature/current/voltage, etc.) are within the absolute maximum ratings and the operating ranges.

Please design the appropriate reliability upon reviewing the Toshiba Semiconductor Reliability Handbook ("Handling Precautions"/"Derating Concept and Methods") and individual reliability data (i.e. reliability test report and estimated failure rate, etc).

Note 2: 500 mW in the range of  $T_a = -40$  to  $65^{\circ}C$ . From  $T_a = 65$  to  $85^{\circ}C$  a derating factor of  $-10$  mW/ $^{\circ}C$  shall be applied until 300 mW.

## Operating Ranges (Note)

Characteristics	Symbol	Rating	Unit
Supply voltage	$V_{CC}$	2.0 to 5.5	V
Input voltage	$V_{IN}$	0 to 5.5	V
Output voltage	$V_{OUT}$	0 to $V_{CC}$	V
Operating temperature	$T_{opr}$	-40 to 85	$^{\circ}C$

Note: The operating ranges must be maintained to ensure the normal operation of the device. Unused inputs must be tied to either  $V_{CC}$  or GND.

## Electrical Characteristics

### DC Characteristics

Characteristics	Symbol	Test Condition		Ta = 25°C			Ta = -40~85°C		Unit		
				V <sub>CC</sub> (V)	Min	Typ	Max	Min		Max	
Positive threshold voltage	V <sub>P</sub>	—		3.0	—	—	2.20	—	2.20	V	
				4.5	—	—	3.15	—	3.15		
				5.5	—	—	3.85	—	3.85		
Negative threshold voltage	V <sub>N</sub>	—		3.0	0.90	—	—	0.90	—	V	
				4.5	1.35	—	—	1.35	—		
				5.5	1.65	—	—	1.65	—		
Hysteresis voltage	V <sub>H</sub>	—		3.0	0.30	—	1.20	0.30	1.20	V	
				4.5	0.40	—	1.40	0.40	1.40		
				5.5	0.50	—	1.60	0.50	1.60		
High-level output voltage	V <sub>OH</sub>	V <sub>IN</sub> = V <sub>IH</sub> or V <sub>IL</sub>		I <sub>OH</sub> = -50 μA	2.0	1.9	2.0	—	1.9	—	V
					3.0	2.9	3.0	—	2.9	—	
				4.5	4.4	4.5	—	4.4	—		
				I <sub>OH</sub> = -4 mA	3.0	2.58	—	—	2.48	—	
4.5	3.94	—	—		3.80	—					
Low-level output voltage	V <sub>OL</sub>	V <sub>IN</sub> = V <sub>IH</sub> or V <sub>IL</sub>		I <sub>OL</sub> = 50 μA	2.0	—	0.0	0.1	—	0.1	V
					3.0	—	0.0	0.1	—	0.1	
					4.5	—	0.0	0.1	—	0.1	
				I <sub>OL</sub> = 4 mA	3.0	—	—	0.36	—	0.44	
					4.5	—	—	0.36	—	0.44	
3-state output off-state current	I <sub>OZ</sub>	V <sub>IN</sub> = V <sub>IH</sub> or V <sub>IL</sub> V <sub>OUT</sub> = V <sub>CC</sub> or GND		5.5	—	—	±0.25	—	±2.50	μA	
Input leakage current	I <sub>IN</sub>	V <sub>IN</sub> = 5.5 V or GND		0 to 5.5	—	—	±0.1	—	±1.0	μA	
Quiescent supply current	I <sub>CC</sub>	V <sub>IN</sub> = V <sub>CC</sub> or GND		5.5	—	—	4.0	—	40.0	μA	

## AC Characteristics (input: $t_r = t_f = 3 \text{ ns}$ )

Characteristics	Symbol	Test Condition	Ta = 25°C			Ta = -40 to 85°C		Unit		
			V <sub>CC</sub> (V)	C <sub>L</sub> (pF)	Min	Typ.	Max		Min	Max
Propagation delay time (An-Yn)	t <sub>pLH</sub>	—	3.3 ± 0.3	15	—	6.0	8.0	1.0	10.0	ns
				50	—	9.0	12.5	1.0	15.0	
	5.0 ± 0.5		15	—	5.0	5.5	1.0	7.0		
			50	—	7.0	8.5	1.0	10.0		
Propagation delay time (CONT-Yn)	t <sub>pLH</sub>	—	3.3 ± 0.3	15	—	8.5	11.5	1.0	13.5	ns
				50	—	13.0	17.0	1.0	20.5	
	5.0 ± 0.5		15	—	6.5	8.0	1.0	9.5		
			50	—	10.5	12.5	1.0	15.0		
3-state output enable time	t <sub>pZL</sub>	R <sub>L</sub> = 1 kΩ	3.3 ± 0.3	15	—	6.0	8.0	1.0	9.5	ns
				50	—	10.5	13.5	1.0	16.5	
	5.0 ± 0.5		15	—	4.5	5.5	1.0	6.5		
			50	—	9.0	10.5	1.0	12.5		
3-state output disable time	t <sub>pLZ</sub>	R <sub>L</sub> = 1 kΩ	3.3 ± 0.3	50	—	12.5	13.5	1.0	16.0	ns
	t <sub>pHZ</sub>		5.0 ± 0.5	50	—	9.0	9.5	1.0	11.0	
Output to output skew	t <sub>osHL</sub>	(Note 1)	3.3 ± 0.3	50	—	—	1.5	—	1.5	ns
	t <sub>osLH</sub>		5.0 ± 0.5	50	—	—	1.0	—	1.0	
Input capacitance	C <sub>IN</sub>	—	—	—	4	10	—	10	pF	
Output capacitance	C <sub>OUT</sub>	—	—	—	6	—	—	—	pF	
Power dissipation capacitance (Note 2)	C <sub>PD</sub>	f <sub>IN</sub> = 1 MHz	—	—	11	—	—	—	pF	

Note 1: Parameter guaranteed by design.

$$t_{osLH} = |t_{pLHm} - t_{pLHn}|, t_{osHL} = |t_{pHLm} - t_{pHLn}|$$

Note 2: C<sub>PD</sub> is defined as the value of the internal equivalent capacitance which is calculated from the operating current consumption without load.

Average operating current can be obtained by the equation:

$$I_{CC (opr)} = C_{PD} \cdot V_{CC} \cdot f_{IN} + I_{CC} / 8 \text{ (per bit)}$$

**Input Equivalent Circuit**

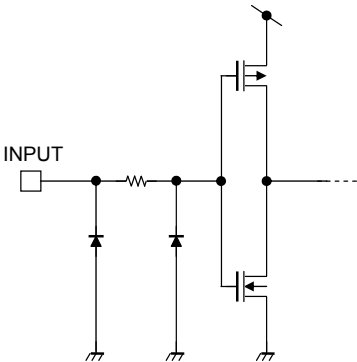

## Package Dimensions

DIP20-P-300-2.54A

Unit : mm

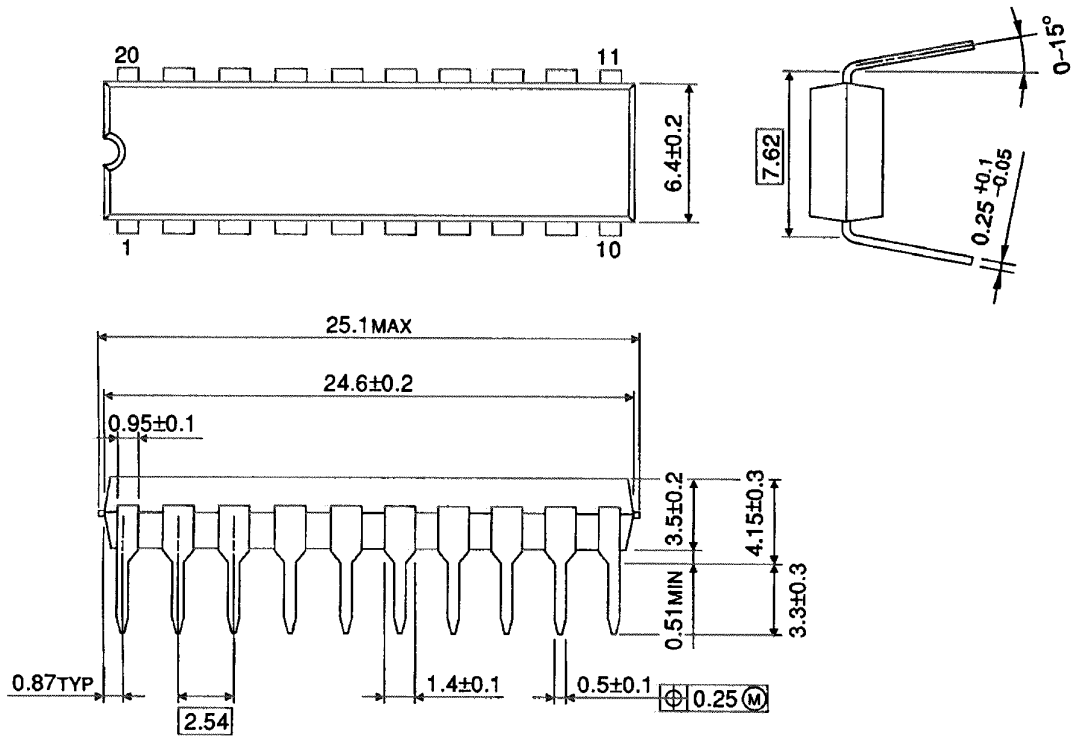

Weight: 1.30 g (typ.)

## Package Dimensions

TSSOP20-P-0044-0.65A

Unit: mm

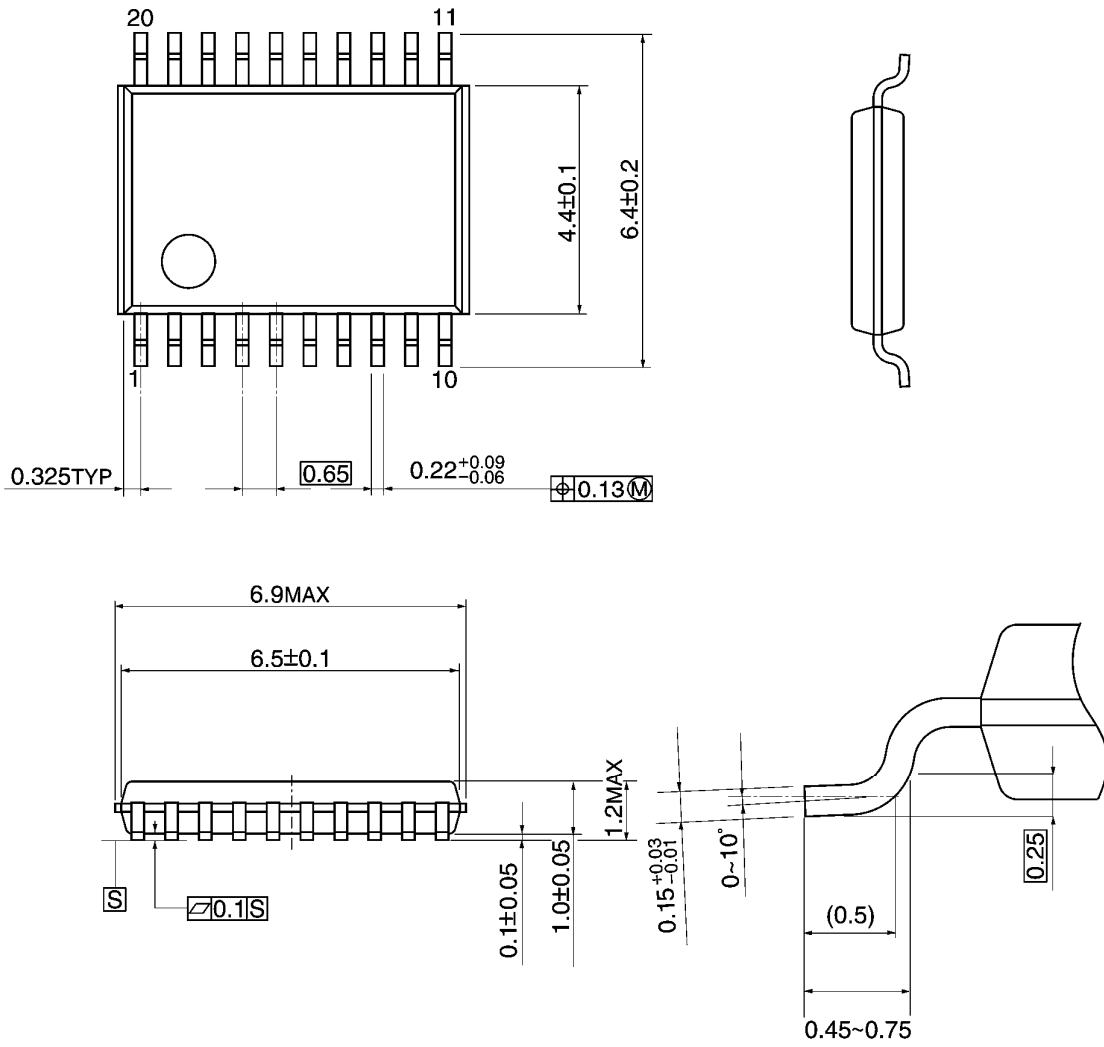

Weight: 0.08 g (typ.)



## Package Dimensions

VSSOP20-P-0030-0.50

Unit: mm

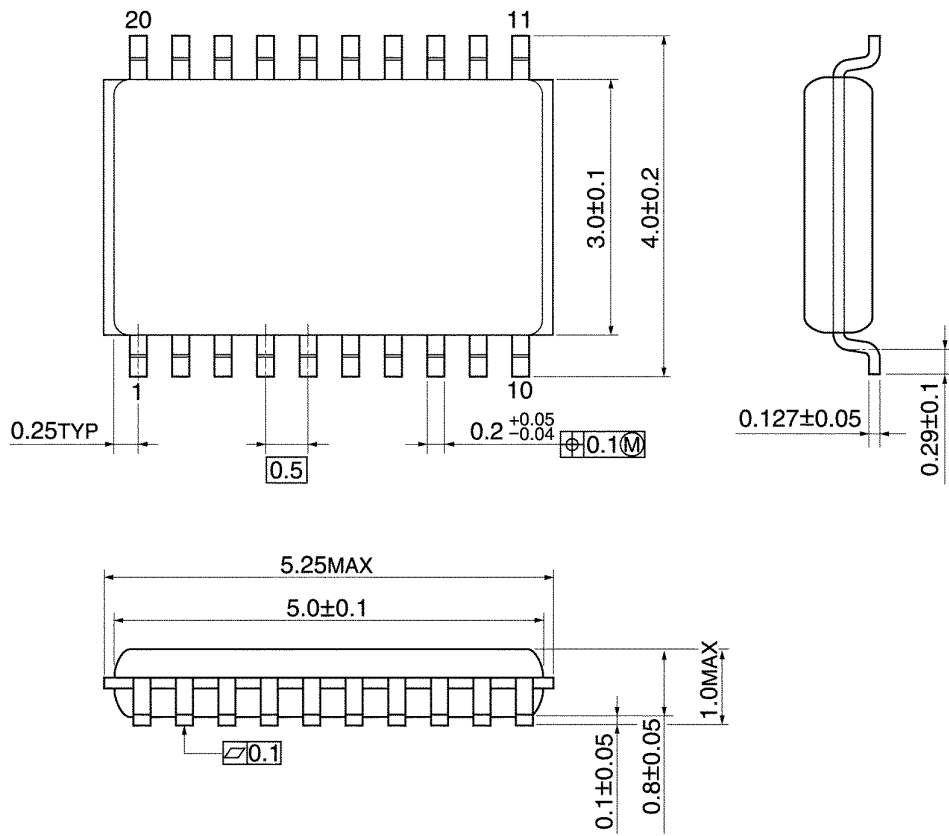

Weight: 0.03 g (typ.)

**RESTRICTIONS ON PRODUCT USE**

20070701-EN GENERAL

- The information contained herein is subject to change without notice.
- TOSHIBA is continually working to improve the quality and reliability of its products. Nevertheless, semiconductor devices in general can malfunction or fail due to their inherent electrical sensitivity and vulnerability to physical stress. It is the responsibility of the buyer, when utilizing TOSHIBA products, to comply with the standards of safety in making a safe design for the entire system, and to avoid situations in which a malfunction or failure of such TOSHIBA products could cause loss of human life, bodily injury or damage to property.  
In developing your designs, please ensure that TOSHIBA products are used within specified operating ranges as set forth in the most recent TOSHIBA products specifications. Also, please keep in mind the precautions and conditions set forth in the "Handling Guide for Semiconductor Devices," or "TOSHIBA Semiconductor Reliability Handbook" etc.
- The TOSHIBA products listed in this document are intended for usage in general electronics applications (computer, personal equipment, office equipment, measuring equipment, industrial robotics, domestic appliances, etc.). These TOSHIBA products are neither intended nor warranted for usage in equipment that requires extraordinarily high quality and/or reliability or a malfunction or failure of which may cause loss of human life or bodily injury ("Unintended Usage"). Unintended Usage include atomic energy control instruments, airplane or spaceship instruments, transportation instruments, traffic signal instruments, combustion control instruments, medical instruments, all types of safety devices, etc.. Unintended Usage of TOSHIBA products listed in this document shall be made at the customer's own risk.
- The products described in this document shall not be used or embedded to any downstream products of which manufacture, use and/or sale are prohibited under any applicable laws and regulations.
- The information contained herein is presented only as a guide for the applications of our products. No responsibility is assumed by TOSHIBA for any infringements of patents or other rights of the third parties which may result from its use. No license is granted by implication or otherwise under any patents or other rights of TOSHIBA or the third parties.
- Please contact your sales representative for product-by-product details in this document regarding RoHS compatibility. Please use these products in this document in compliance with all applicable laws and regulations that regulate the inclusion or use of controlled substances. Toshiba assumes no liability for damage or losses occurring as a result of noncompliance with applicable laws and regulations.