

TC74VHC393F, TC74VHC393FN, TC74VHC393FT

Dual Binary Counter

The TC74VHC393 is an advanced high speed CMOS 4-BIT BINARY COUNTER fabricated with silicon gate C²MOS technology.

It achieves the high speed operation similar to equivalent Bipolar Schottky TTL while maintaining the CMOS low power dissipation.

It contains two independent counter circuits in one package, so that counting or frequency division of eight binary bits can be achieved with one IC.

This device changes state on the negative going transition of the $\overline{\text{CLOCK}}$ pulse. The counter can be reset to "0" (QA to QD = "L") by a high at the CLEAR input regardless of other inputs.

An input protection circuit ensures that 0 to 5.5 V can be applied to the input pins without regard to the supply voltage. This device can be used to interface 5 V to 3 V systems and two supply systems such as battery back up. This circuit prevents device destruction due to mismatched supply and input voltages.

Features

- High speed: $f_{\text{max}} = 170 \text{ MHz}$ (typ.) at $V_{\text{CC}} = 5 \text{ V}$
- Low power dissipation: $I_{\text{CC}} = 4 \mu\text{A}$ (max) at $T_a = 25^\circ\text{C}$
- High noise immunity: $V_{\text{NIH}} = V_{\text{NIL}} = 28\% V_{\text{CC}}$ (min)
- Power down protection is provided on all inputs.
- Balanced propagation delays: $t_{\text{pLH}} \approx t_{\text{pHL}}$
- Wide operating voltage range: $V_{\text{CC (opr)}} = 2 \text{ to } 5.5 \text{ V}$
- Low noise: $V_{\text{OLP}} = 0.8 \text{ V}$ (max)
- Pin and function compatible with 74ALS393

Note: xxxFN (JEDEC SOP) is not available in Japan.

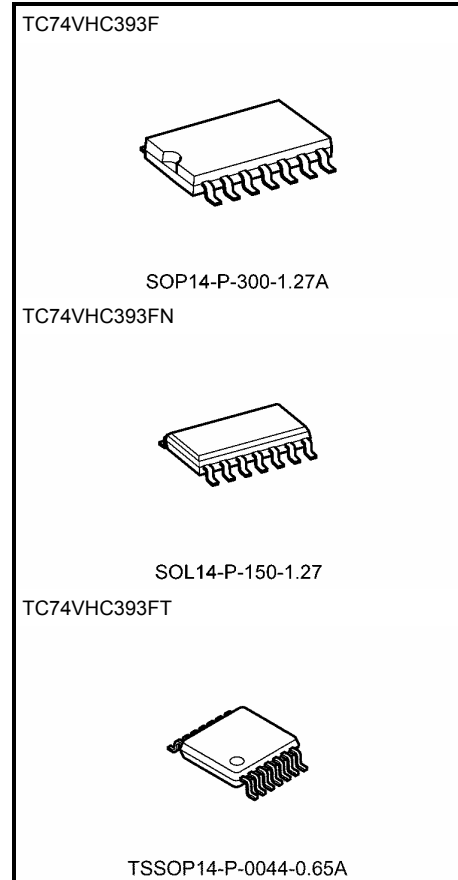

Weight	
SOP14-P-300-1.27A	: 0.18 g (typ.)
SOL14-P-150-1.27	: 0.12 g (typ.)
TSSOP14-P-0044-0.65A	: 0.06 g (typ.)

Pin Assignment

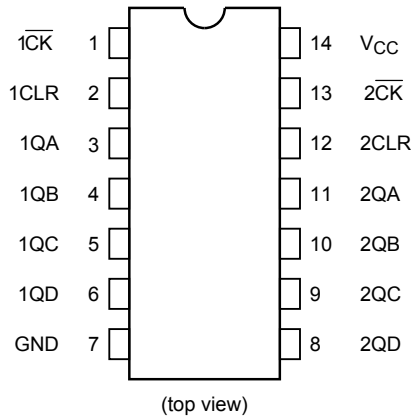

IEC Logic Symbol

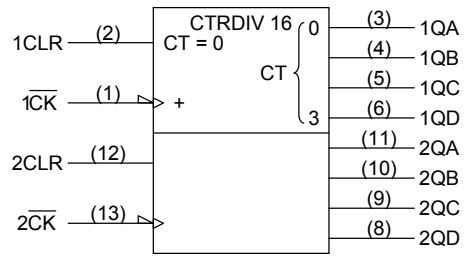

Truth Table

Inputs		Outputs			
\overline{CK}	CLR	QA	QB	QC	QD
X	H	L	L	L	L
\downarrow	L	Count Up			
\uparrow	L	No Change			

X: Don't care

System Diagram

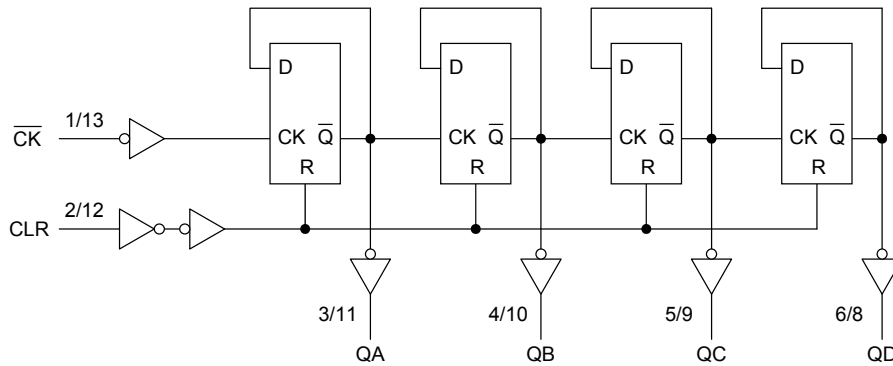

Timing Chart

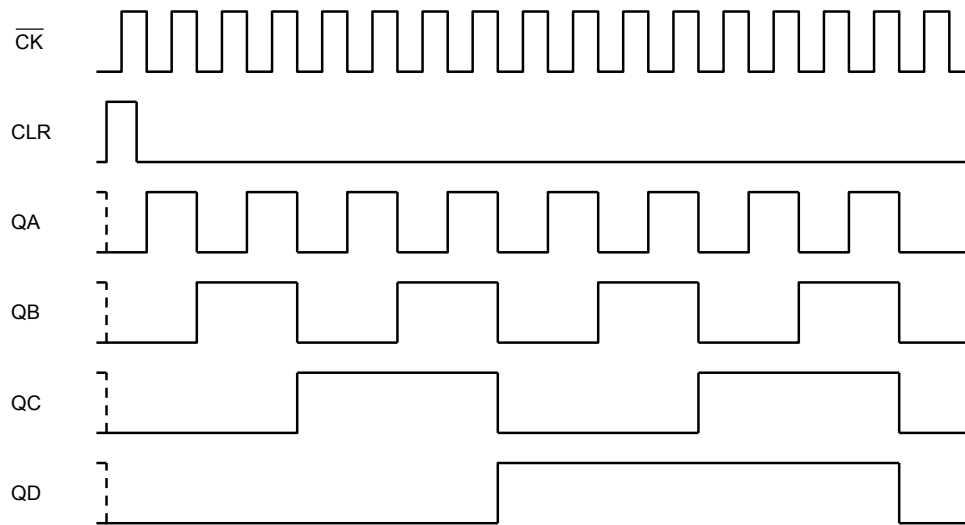

Absolute Maximum Ratings (Note)

Characteristics	Symbol	Rating	Unit
Supply voltage range	V_{CC}	-0.5 to 7.0	V
DC input voltage	V_{IN}	-0.5 to 7.0	V
DC output voltage	V_{OUT}	-0.5 to $V_{CC} + 0.5$	V
Input diode current	I_{IK}	-20	mA
Output diode current	I_{OK}	± 20	mA
DC output current	I_{OUT}	± 25	mA
DC V_{CC} /ground current	I_{CC}	± 75	mA
Power dissipation	P_D	180	mW
Storage temperature	T_{stg}	-65 to 150	$^{\circ}C$

Note: Exceeding any of the absolute maximum ratings, even briefly, lead to deterioration in IC performance or even destruction.

Using continuously under heavy loads (e.g. the application of high temperature/current/voltage and the significant change in temperature, etc.) may cause this product to decrease in the reliability significantly even if the operating conditions (i.e. operating temperature/current/voltage, etc.) are within the absolute maximum ratings and the operating ranges.

Please design the appropriate reliability upon reviewing the Toshiba Semiconductor Reliability Handbook ("Handling Precautions"/"Derating Concept and Methods") and individual reliability data (i.e. reliability test report and estimated failure rate, etc).

Operating Ranges (Note)

Characteristics	Symbol	Rating	Unit
Supply voltage	V_{CC}	2.0 to 5.5	V
Input voltage	V_{IN}	0 to 5.5	V
Output voltage	V_{OUT}	0 to V_{CC}	V
Operating temperature	T_{opr}	-40 to 85	$^{\circ}C$
Input rise and fall time	dt/dv	0 to 100 ($V_{CC} = 3.3 \pm 0.3$ V) 0 to 20 ($V_{CC} = 5 \pm 0.5$ V)	ns/V

Note: The operating ranges must be maintained to ensure the normal operation of the device. Unused inputs must be tied to either VCC or GND.

Electrical Characteristics

DC Characteristics

Characteristics	Symbol	Test Condition		Ta = 25°C			Ta = -40 to 85°C		Unit	
				V _{CC} (V)	Min	Typ.	Max	Min		Max
High-level input voltage	V _{IH}	—		2.0 3.0 to 5.5	1.50 V _{CC} × 0.7	— —	— —	1.50 V _{CC} × 0.7	— —	V
Low-level input voltage	V _{IL}	—		2.0 3.0 to 5.5	— —	— —	0.50 V _{CC} × 0.3	— —	0.50 V _{CC} × 0.3	V
High-level output voltage	V _{OH}	V _{IN} = V _{IH} or V _{IL}	I _{OH} = -50 μA	2.0 3.0 4.5	1.9 2.9 4.4	2.0 3.0 4.5	— — —	1.9 2.9 4.4	— — —	V
			I _{OH} = -4 mA	3.0	2.58	—	—	2.48	—	
			I _{OH} = -8 mA	4.5	3.94	—	—	3.80	—	
Low-level output voltage	V _{OL}	V _{IN} = V _{IH} or V _{IL}	I _{OL} = 50 μA	2.0 3.0 4.5	— — —	0.0 0.0 0.0	0.1 0.1 0.1	— — —	0.1 0.1 0.1	V
			I _{OL} = 4 mA	3.0	—	—	0.36	—	0.44	
			I _{OL} = 8 mA	4.5	—	—	0.36	—	0.44	
Input leakage current	I _{IN}	V _{IN} = 5.5 V or GND		0 to 5.5	—	—	±0.1	—	±1.0	μA
Quiescent supply current	I _{CC}	V _{IN} = V _{CC} or GND		5.5	—	—	4.0	—	40.0	μA

Timing Requirements (input: t_r = t_f = 3 ns)

Characteristics	Symbol	Test Condition		Ta = 25°C			Ta = -40 to 85°C	Unit
				V _{CC} (V)	Typ.	Limit	Limit	
Minimum pulse width (CK)	t _w (H)	—		3.3 ± 0.3	—	5.0	5.0	ns
	t _w (L)	—		5.0 ± 0.5	—	5.0	5.0	
Minimum pulse width (CLR)	t _w (H)	—		3.3 ± 0.3	—	5.0	5.0	ns
		—		5.0 ± 0.5	—	5.0	5.0	
Minimum removal time	t _{rem}	—		3.3 ± 0.3	—	5.0	5.0	ns
		—		5.0 ± 0.5	—	4.0	4.0	

AC Characteristics (input: $t_r = t_f = 3 \text{ ns}$)

Characteristics	Symbol	Test Condition	Ta = 25°C			Ta = -40 to 85°C		Unit		
			V _{CC} (V)	C _L (pF)	Min	Typ.	Max		Min	Max
Propagation delay time ($\overline{\text{CK}}$ -QA)	t_{pLH}	—	3.3 ± 0.3	15	—	8.6	13.2	1.0	15.5	ns
				50	—	11.1	16.7	1.0	19.0	
	5.0 ± 0.5		15	—	5.8	8.5	1.0	10.0		
			50	—	7.3	10.5	1.0	12.0		
Propagation delay time ($\overline{\text{CK}}$ -QB)	t_{pLH}	—	3.3 ± 0.3	15	—	10.2	15.8	1.0	18.5	ns
				50	—	12.7	19.3	1.0	22.0	
	5.0 ± 0.5		15	—	6.8	9.8	1.0	11.5		
			50	—	8.3	11.8	1.0	13.5		
Propagation delay time ($\overline{\text{CK}}$ -QC)	t_{pLH}	—	3.3 ± 0.3	15	—	11.7	18.0	1.0	21.0	ns
				50	—	14.2	21.5	1.0	24.5	
	5.0 ± 0.5		15	—	7.7	11.2	1.0	13.0		
			50	—	9.2	13.2	1.0	15.0		
Propagation delay time ($\overline{\text{CK}}$ -QD)	t_{pLH}	—	3.3 ± 0.3	15	—	13.0	19.7	1.0	23.0	ns
				50	—	15.5	23.2	1.0	26.5	
	5.0 ± 0.5		15	—	8.5	12.5	1.0	14.5		
			50	—	10.0	14.5	1.0	16.5		
Propagation delay time (CLR-Qn)	t_{pHL}	—	3.3 ± 0.3	15	—	7.9	12.3	1.0	14.5	ns
				50	—	10.4	15.8	1.0	18.0	
			5.0 ± 0.5	15	—	5.4	8.1	1.0	9.5	
				50	—	6.9	10.1	1.0	11.5	
Maximum clock frequency	f_{max}	—	3.3 ± 0.3	15	75	120	—	65	—	MHz
				50	45	65	—	35	—	
			5.0 ± 0.5	15	125	170	—	105	—	
				50	85	115	—	75	—	
Input capacitance	C _{IN}	—	—	4	10	—	10	pF		
Power dissipation capacitance	C _{PD}	(Note)	—	23	—	—	—	pF		

Note: C_{PD} is defined as the value of the internal equivalent capacitance which is calculated from the operating current consumption without load.

Average operating current can be obtained by the equation:

$$I_{CC}(\text{opr}) = C_{PD} \cdot V_{CC} \cdot f_{IN} + I_{CC}/2 \text{ (per counter)}$$

Noise Characteristics (input: $t_r = t_f = 3 \text{ ns}$)

Characteristics	Symbol	Test Condition	Ta = 25°C			Unit
			V _{CC} (V)	Typ.	Max	
Quiet output maximum dynamic V _{OL}	V _{OLP}	C _L = 50 pF	5.0	0.5	0.8	V
Quiet output minimum dynamic V _{OL}	V _{OLV}	C _L = 50 pF	5.0	-0.5	-0.8	V
Minimum high level dynamic input voltage	V _{IHD}	C _L = 50 pF	5.0	—	3.5	V
Maximum low level dynamic input voltage	V _{ILD}	C _L = 50 pF	5.0	—	1.5	V

Input Equivalent Circuit

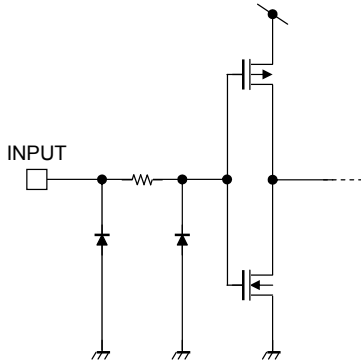

Package Dimensions

SOP14-P-300-1.27A

Unit: mm

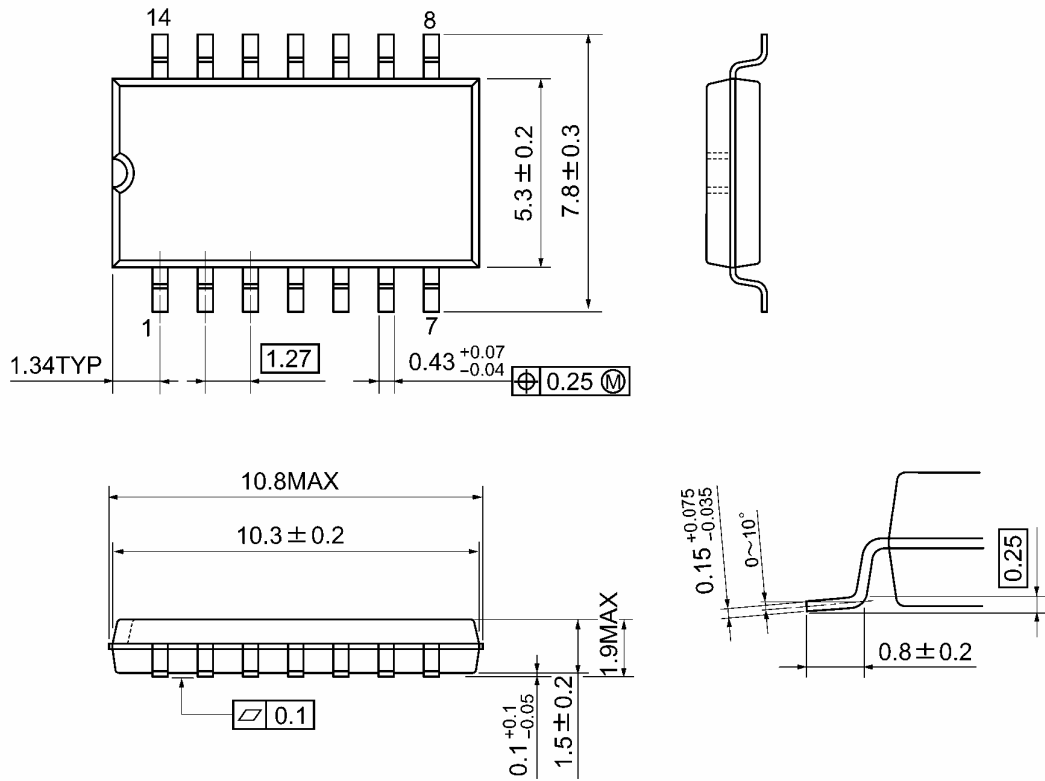

Weight: 0.18 g (typ.)

Package Dimensions (Note)

SOL14-P-150-1.27

Unit : mm

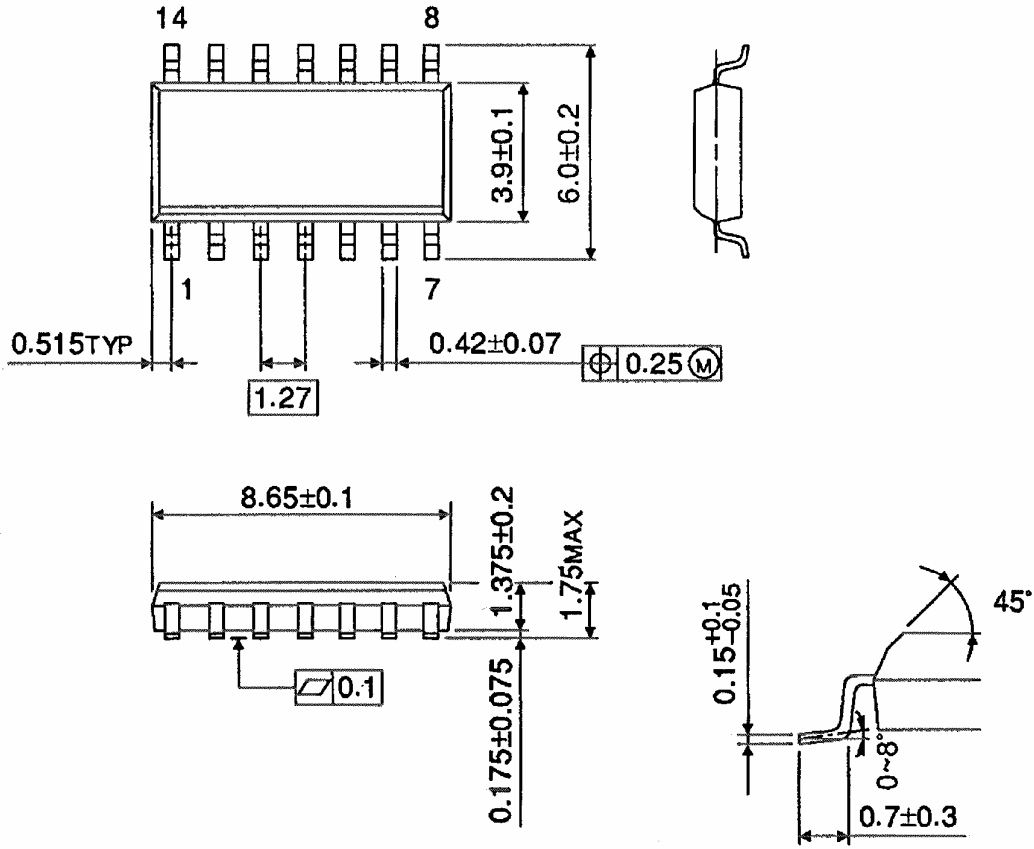

Note: This package is not available in Japan.

Weight: 0.12 g (typ.)

Package Dimensions

TSSOP14-P-0044-0.65A

Unit: mm

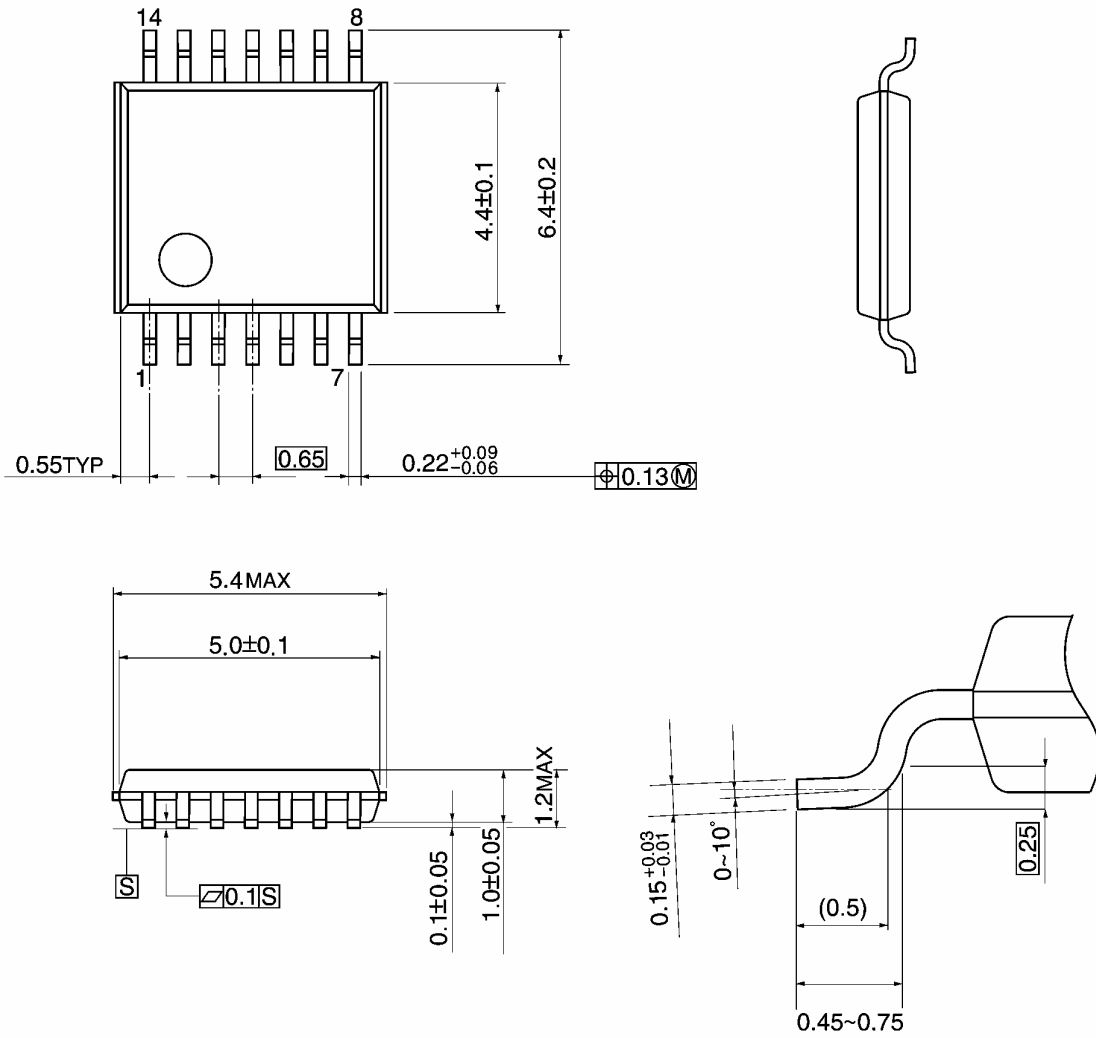

Weight: 0.06 g (typ.)

RESTRICTIONS ON PRODUCT USE

20070701-EN GENERAL

- The information contained herein is subject to change without notice.
- TOSHIBA is continually working to improve the quality and reliability of its products. Nevertheless, semiconductor devices in general can malfunction or fail due to their inherent electrical sensitivity and vulnerability to physical stress. It is the responsibility of the buyer, when utilizing TOSHIBA products, to comply with the standards of safety in making a safe design for the entire system, and to avoid situations in which a malfunction or failure of such TOSHIBA products could cause loss of human life, bodily injury or damage to property.
In developing your designs, please ensure that TOSHIBA products are used within specified operating ranges as set forth in the most recent TOSHIBA products specifications. Also, please keep in mind the precautions and conditions set forth in the "Handling Guide for Semiconductor Devices," or "TOSHIBA Semiconductor Reliability Handbook" etc.
- The TOSHIBA products listed in this document are intended for usage in general electronics applications (computer, personal equipment, office equipment, measuring equipment, industrial robotics, domestic appliances, etc.). These TOSHIBA products are neither intended nor warranted for usage in equipment that requires extraordinarily high quality and/or reliability or a malfunction or failure of which may cause loss of human life or bodily injury ("Unintended Usage"). Unintended Usage include atomic energy control instruments, airplane or spaceship instruments, transportation instruments, traffic signal instruments, combustion control instruments, medical instruments, all types of safety devices, etc.. Unintended Usage of TOSHIBA products listed in this document shall be made at the customer's own risk.
- The products described in this document shall not be used or embedded to any downstream products of which manufacture, use and/or sale are prohibited under any applicable laws and regulations.
- The information contained herein is presented only as a guide for the applications of our products. No responsibility is assumed by TOSHIBA for any infringements of patents or other rights of the third parties which may result from its use. No license is granted by implication or otherwise under any patents or other rights of TOSHIBA or the third parties.
- Please contact your sales representative for product-by-product details in this document regarding RoHS compatibility. Please use these products in this document in compliance with all applicable laws and regulations that regulate the inclusion or use of controlled substances. Toshiba assumes no liability for damage or losses occurring as a result of noncompliance with applicable laws and regulations.