

Features

- Single-Supply Operation (+2V to +6V)
- Rail-to-Rail Analog Signal Dynamic Range
- Low On-Resistance (6-Ohm typical with 5V supply)
Minimizes Distortion and Error Voltages
- On-Resistance Flatness, 3-Ohm typical
- Low Charge Injection Reduces Glitch Errors.
Q=4pC (typical)
- Replaces Mechanical Relays
- High Speed: $t_{ON} = 10\text{ns}$ typical
- Wide -3dB Bandwidth: 300 MHz (typical)
- High-Current Channel Capability: >100mA
- TTL/CMOS Logic Compatible
- Low Power Consumption (0.5 μW typical)
- Small outline transistor package minimizes board area
-65 mil wide SOT23-5 (T5)

Applications

- Audio, Video Switching and Routing
- Battery-Powered Communication Systems
- Computer Peripherals
- Telecommunications
- Portable Instrumentation
- Mechanical Relay Replacement
- Cell Phones
- PDAs

Truth Table

$\overline{\text{OE}}$	PI5A125
0	ON
1	OFF

Switch shown for Logic "0" input

Description

The PI5A125 is a single analog switch designed for single-supply operation. This high-precision device is ideal for low-distortion audio, video, signal switching and routing.

The PI5A125 is a single-pole single-throw (SPST), normally closed (NC) switch. The switch is open when $\overline{\text{OE}}$ is HIGH.

This switch conducts current equally well in either direction when on. When off, it blocks voltages up to V_{CC} .

The PI5A125 is fully specified with +5V, and +3.3V supplies. With +5V, it guarantees <10-ohms ON-resistance. ON-resistance flatness is less than 5-ohms over the specified range. The switch also guarantees fast switching speeds ($t_{ON} < 20\text{ns}$).

This product is available in a 5-pin SOT23 plastic package for operation over the industrial (-40°C to +85°C) temperature range.

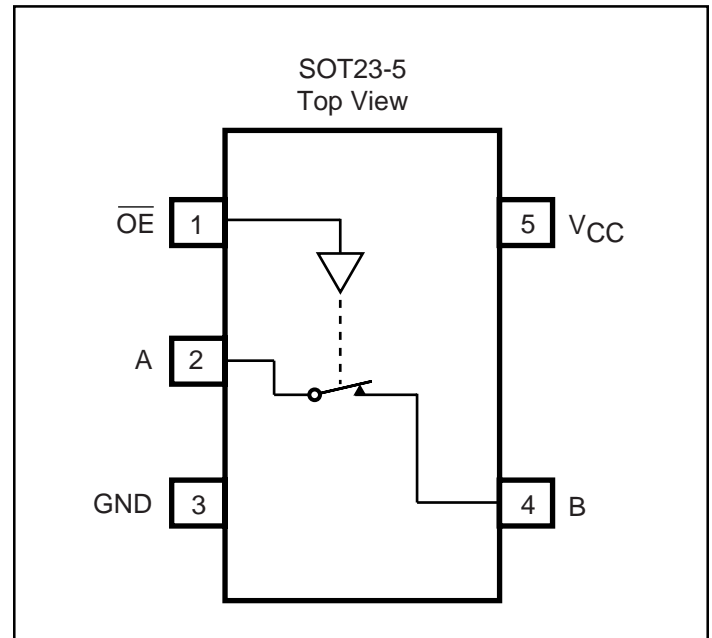
Functional Diagram, Pin Configuration

Electrical Specifications - Single +5V Supply ($V_{CC} = +5V \pm 10\%$, $GND = 0V$, $V_{INH} = 2.4V$, $V_{INL} = 0.8V$)

Description	Parameter	Conditions	Temp. (°C)	Min. ⁽²⁾	Typ. ⁽¹⁾	Max. ⁽²⁾	Units
Analog Switch							
Analog Signal Range ⁽³⁾	V_{ANALOG}		Full	0		V_{CC}	V
On-Resistance	R_{ON}	$V_{CC} = 4.5V$, $I_B = -30$ mA, $V_A = +2.5V$	25		8	10	Ω
			Full			12	
On-Resistance Flatness ⁽⁵⁾	$R_{FLAT(ON)}$	$V_{CC} = 5V$, $I_B = -30$ mA, $V_A = 1V, 2.5V, 4V$	25		2.5	3.5	Ω
			Full			4	
Off Leakage Current ⁽⁶⁾	$I_{A(OFF)}$ or $I_{B(OFF)}$	$V_{CC} = 5.5V$, $V_B = 0V$, $V_A = 4.5V$	25		0.20		nA
			Full	-80		80	
On Leakage Current ⁽⁶⁾	$I_{A(ON)}$ or $I_{B(ON)}$	$V_+ = 5.5V$, $V_B = V_A = +4.5V$	25		0.20		nA
			Full	-80		80	
Logic Input							
Input High Voltage	V_{IH}	Guaranteed Logic High Level	Full	2			V
Input Low Voltage	V_{IL}	Guaranteed Logic Low Level				0.8	
Input Current with Input Voltage High	I_{INH}	$V_{IN} = 2.4V$, all others = 0.8V		-1	0.005	1	μA
Input Current with Input Voltage Low	I_{INL}	$V_{IN} = 0.8V$, all others = 2.4V					
Dynamic							
Turn-On Time	t_{ON}	$V_{CC} = 5V$, see Figure 1	25		7	15	nc
			Full			20	
Turn-Off Time	t_{OFF}	$V_{COM} = \pm 3V$, see Figure 2	25		1	7	nc
			Full		2	5	
Charge Injection ⁽³⁾	Q	$C_L = 1nF$, $V_{GEN} = 0V$, $R_{GEN} = 0\Omega$, see Figure 2				10	pC
Off Isolation	$OIRR$	$R_L = 50\Omega$, $C_L = 5pF$, $f = 10$ MHz, see Figure 3	25				dB
A or B Off Capacitance	$C_{(OFF)}$	$f = 1$ kHz, see Figure 4			5.5		pF
On Capacitance	$C_{(ON)}$	$f = 1$ kHz, see Figure 5			5.5		
-3dB Bandwidth	BW	$R_L = 50\Omega$, see Figure 6			300		MHz
Supply							
Power-Supply Range	V_{CC}		Full	2		6	V
Positive Supply Current	I_{CC}	$V_+ = 5.5V$, $V_{IN} = 0V$ or V_{CC} , All channels on or off					1

Absolute Maximum Ratings

Voltages Referenced to GND	
V _{CC}	-0.5V to +7V
V _{OE} , V _A , V _B ⁽¹⁾	-0.5V to V _{CC} +2V
.....	or 30mA, whichever occurs first
Current (any terminal except A, B)	30mA
Current: A,B (pulsed at 1ms, 10% duty cycle)	120mA

Thermal Information

Continuous Power Dissipation	
SOT23-5 (derate 7mW/°C above +70°C)	550mW
Storage Temperature	-65°C to +150°C
Lead Temperature (soldering, 10s)	+300°C

Note 1:

Signals on \overline{OE} , A, B exceeding V_{CC} or GND are clamped by internal diodes. Limit forward diode current to 30mA.

Caution: Stresses beyond those listed under “Absolute Maximum Ratings” may cause permanent damage to the device. This is a stress only rating and operation of the device at these or any other conditions beyond those indicated in the operational sections of this specification is not implied.

Electrical Specifications-Single +3.3V Supply (V_{CC} = +3.3V ± 10%, GND = 0V, V_{INH} = 2.4V, V_{INL} = 0.8V)

Parameter	Symbol	Conditions	Temp(°C)	Min. ⁽¹⁾	Typ. ⁽²⁾	Max. ⁽¹⁾	Units
Analog Switch							
Analog Signal Range ⁽³⁾	V _{ANALOG}			0		V _{CC}	V
On-Resistance	R _{ON}	V _{CC} = 3V, I _B = -30mA, V _A = 1.5V	25		12	18	Ω
			Full			22	
On-Resistance Flatness ^(3,5)	R _{FLAT(ON)}	V _{CC} = 3.3V, I _B = -30mA, V _A = 0.8V, 2.5V	25		0.5	4	
			Full			5	
Dynamic							
Turn-On Time	t _{ON}	V _{CC} = 3.3V to V _{NO} or V _{NC} = 1.5V, Fig.1	25		15	25	ns
			Full			40	
Turn-Off Time	t _{OFF}		25		1.5	12	
			Full			20	
Charge Injection ⁽³⁾	Q	C _L = 1nf, V _{GEN} = 0V, R _{GEN} = 0V, Fig.2	25		1.3	10	pC
Supply							
I _{CC}	Positive Supply Current	V _{CC} = 3.6V, V _{in} = 0V or V _{CC} All channels on or off	Full			1	μA

Notes:

- The algebraic convention, where the most negative value is a minimum and the most positive is a maximum, is used in this data sheet.
- Typical values are for DESIGN AID ONLY, not guaranteed or subject to production testing.
- Guaranteed by design
- ΔR_{ON} = R_{ON} max - R_{ON} min
- Flatness is defined as the difference between the maximum and minimum value of on-resistance measured.
- Leakage parameters are 100% tested at maximum rated hot temperature and guaranteed by correlation at +25°C.
- Off Isolation = 20log₁₀ V_B / V_A. See Figure 3.

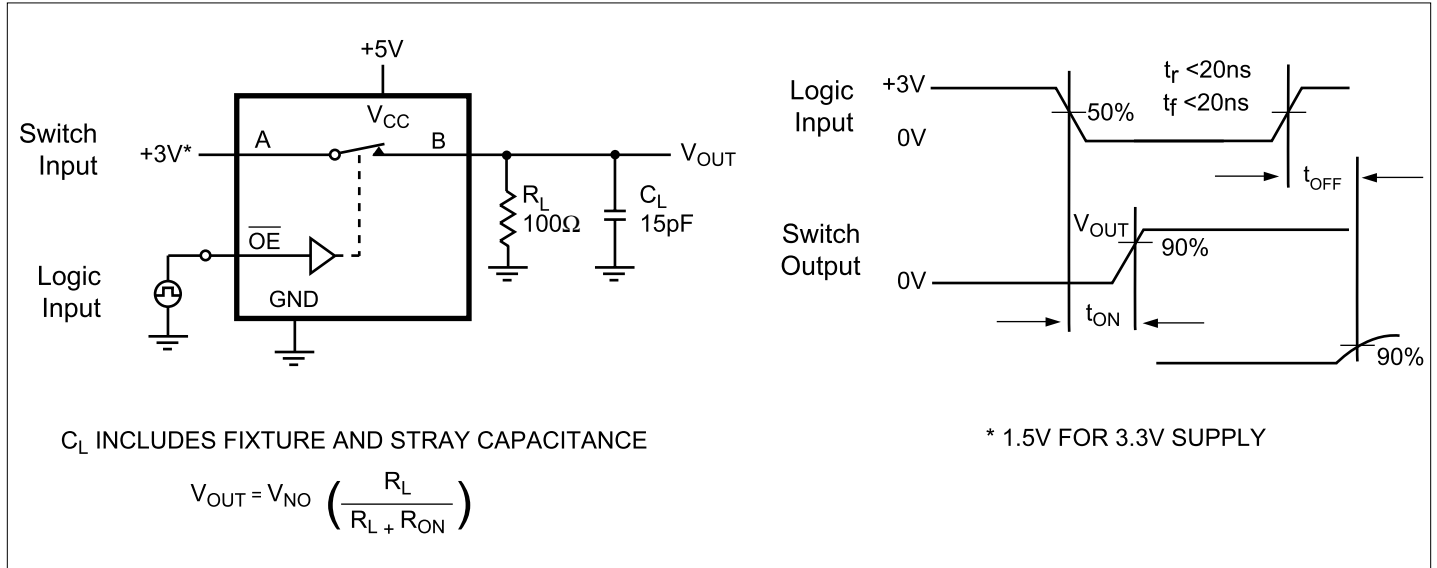
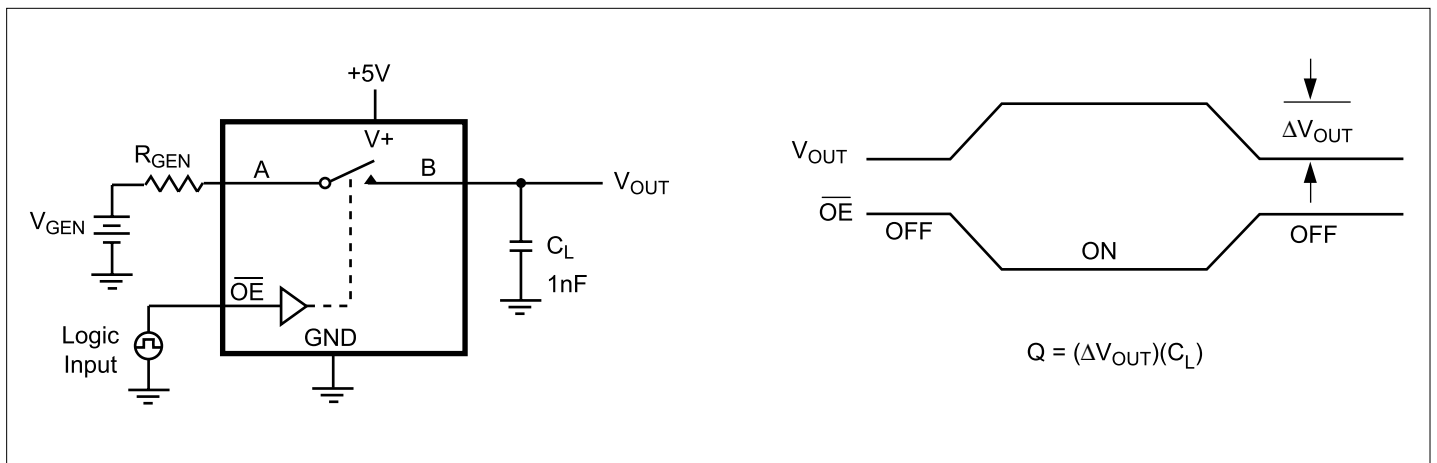
Test Circuits/Timing Diagrams

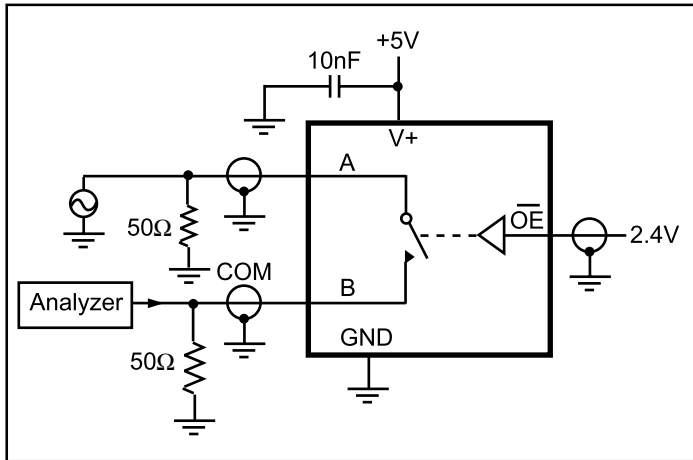
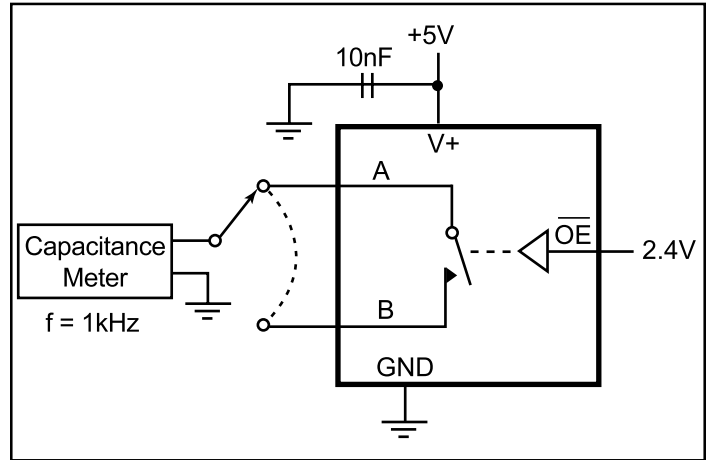
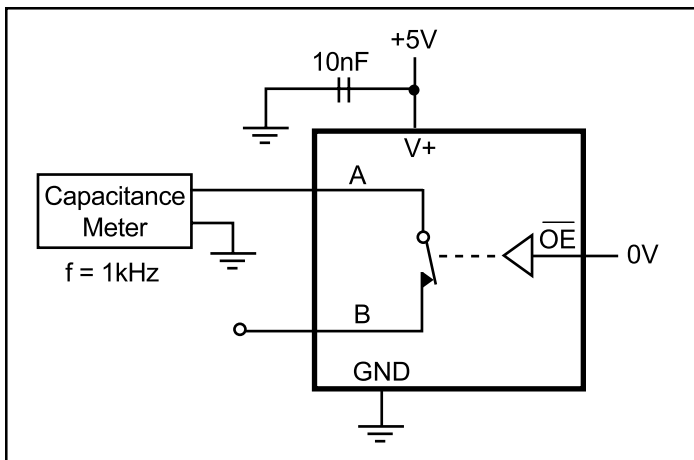
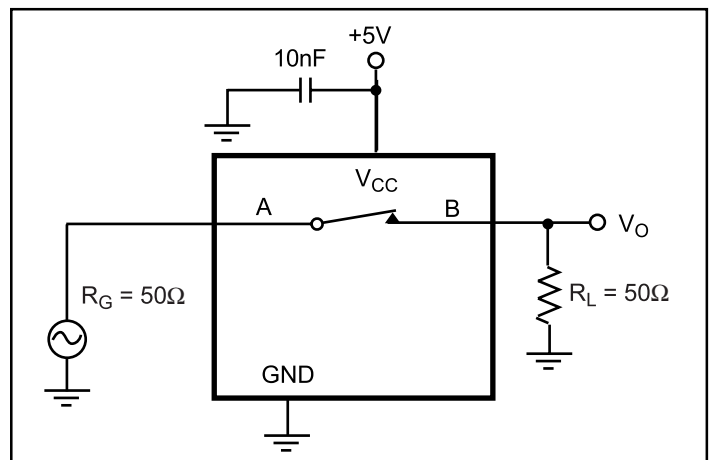
Figure 1. Switching Time

Figure 2. Charge Injection

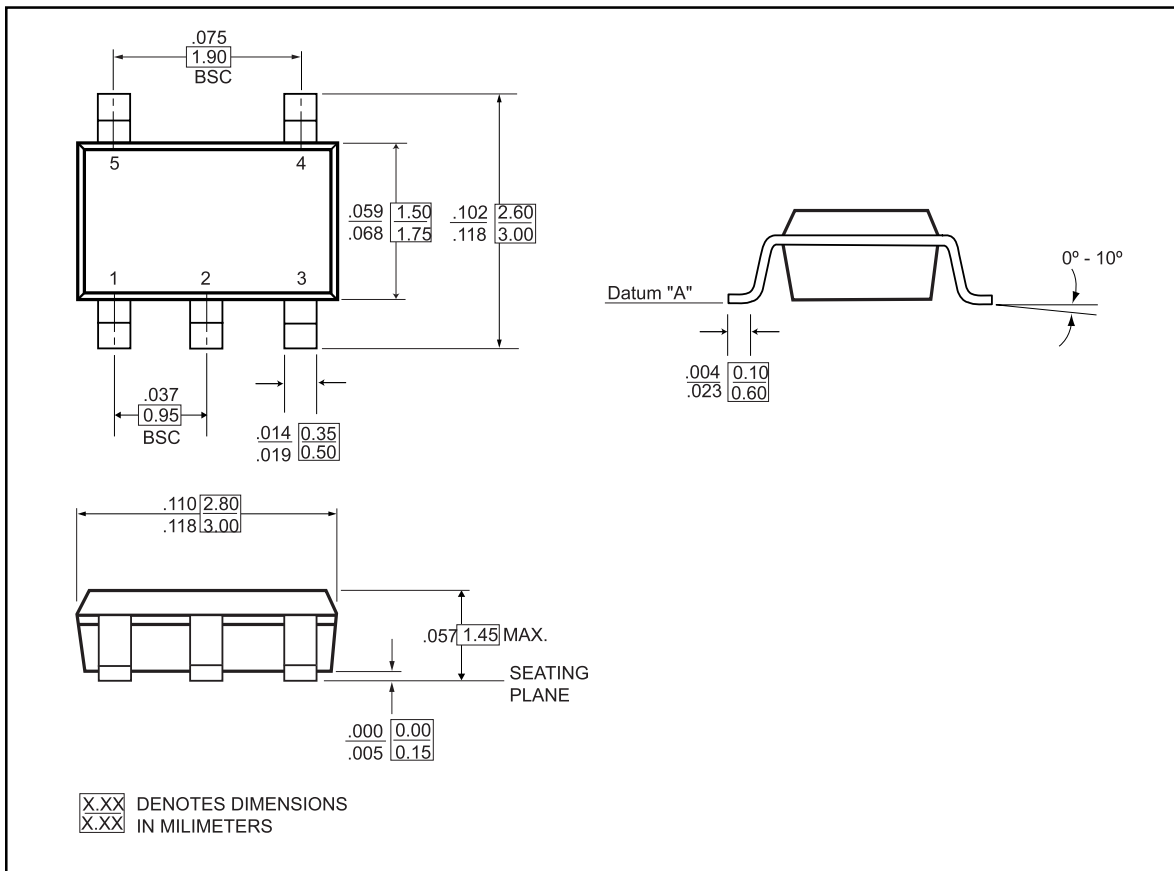
Test Circuits/Timing Diagrams (continued)

Figure 3. Off Isolation

Figure 4. Channel-Off Capacitance

Figure 5. Channel-On Capacitance

Figure 6. Bandwidth

Small Outline Transistor Package - SOT23-5 (T5)



Ordering Information

P/N	Package
PI5A125TX	SOT23-5