

Precision Wide Bandwidth Analog Switches

Features

- Single-Supply Operation (+2V to +6V)
- Rail-to-Rail Analog Signal Dynamic Range
- Low On-Resistance (6Ω typ with 5V supply)
Minimizes Distortion and Error Voltages
- On-Resistance Matching Channels, 0.8Ω typ
- On-Resistance Flatness, 3Ω typ
- Low Charge Injection Reduces Glitch Errors. Q = 4pC typ
- Replaces Mechanical Relays
- High Speed. $t_{ON} = 10\text{ns}$ typ
- Low Off-Isolation: -72dB @ 1MHz
- Wide -3dB Bandwidth: 170 MHz
- High-Current Channel Capability: >100mA
- TTL/CMOS Logic Compatible
- Low Power Consumption (0.5μW typ)
- Pin-compatible with DG41X, MAX31X

Applications

- Audio, Video Switching and Routing
- Battery-Powered Communication Systems
- Computer Peripherals
- Telecommunications
- Portable Instrumentation

Description

The PI5A317A/381A/319A are analog switches designed for single-supply operation. These high-precision device is ideal for low-distortion audio, video, signal switching and routing.

The PI5A317A is a single-pole single-throw (SPST), normally closed (NC) switch. The PI5A318A has the same pinout but is a single-pole, single-throw (SPST, normally open (NO) function. The PI5A319A is a single-pole, double-throw (SPDT) switch

Each switch conducts current equally well in either direction when on. When off, they block voltages up to V_{CC} .

The PI5A317A/381A/319A are fully specified with +5V and +3.3V supplies. With +5V, they guarantee <10Ω on-resistance. On-resistance matching between channels is within 2Ω. On-resistance flatness is less than 5Ω over the specified range. This switch family also guarantees fast switching speeds ($t_{ON} < 20\text{ns}$).

These products are available in a 8-pin narrow body SOIC, and PDIP packages for operation over the industrial (-40°C to +85 °C) temperature range.

Ordering Information

| Part Number | Package |
|-------------|--------------------|
| PI5A317AP | 8-Pin PDIP |
| PI5A317AW | Narrow Body SOIC-8 |
| PI5A318AP | 8-Pin PDIP |
| PI5A318AW | Narrow Body SOIC-8 |
| PI5A319AP | 8-Pin PDIP |
| PI5A319AW | Narrow Body SOIC-8 |

Functional Diagram, Pin Configuration and Truth Table

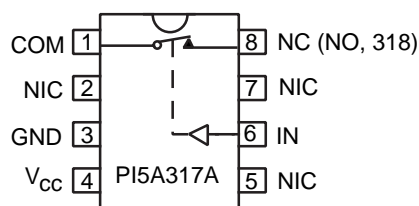

| IN | PI5A317A | PI5A318A |
|----|----------|----------|
| 0 | ON | OFF |
| 1 | OFF | ON |

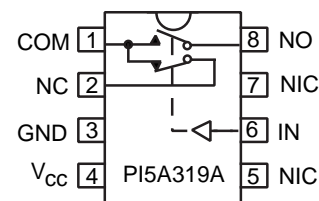

| IN | SW1 | SW2 |
|----|-----|-----|
| 0 | ON | OFF |
| 1 | OFF | ON |

Switches shown for Logic "0" input
NC = Normally Open, NO = Normally Closed, NIC = Not Internally Connected

For free samples and the latest data sheet visit: www.pericom.com, or phone 1 800-435-2336

Maximum Ratings

(Above which the useful life may be impaired. For user guidelines, not tested.)

| | |
|---|-------------------|
| Storage Temperature | -65°C to +150°C |
| Ambient Temperature with Power Applied | -40°C to +85°C |
| Supply Voltage to Ground Potential (Inputs & Vcc Only) | -0.5V to +7.0V |
| Supply Voltage to Ground Potential (Outputs & D/O Only) | -0.5V to +7.0V |
| DC Input Voltage | -0.5V to Vcc+0.5V |
| DC Output Current | 120 mA |
| Power Dissipation | 0.5W |

Note:

Stresses greater than those listed under MAXIMUM RATINGS may cause permanent damage to the device. This is a stress rating only and functional operation of the device at these or any other conditions above those indicated in the operational sections of this specification is not implied. Exposure to absolute maximum rating conditions for extended periods may affect reliability.

Single 5.0V Supply

DC Electrical Characteristics (Over the Operating Range, TA = -40°C to +85°C, VCC = 5V ±10%, GND = 0V)

| Parameters | Description | Test Conditions ⁽¹⁾ | Min. | Typ ⁽²⁾ | Max. | Units |
|---------------------|------------------------------------|----------------------------------|------|--------------------|------|-------|
| VANALOG | Analog Signal Range ⁽²⁾ | | 0 | — | 5 | V |
| RON | ON-Resistance | INC or NO = 10 mA to 30 mA | — | 6 | 12 | Ω |
| ΔRON | Match Between Channels | (319A) | — | 0.8 | 2 | Ω |
| RFLAT(ON) | RON Flatness ⁽⁴⁾ | ION = 1 mA, VNO, VNC = 0V to VCC | — | 3 | 5 | Ω |
| INO(OFF) INC(ON) | Off Leakage Current | VNO, VNC = 4.5V | -80 | — | 80 | nA |
| ICOM(ON) | On Leakage Current | VNO, VNC = 4.5V | -30 | — | 30 | nA |
| IO | Output Current | VNO, VNC or VCOM = 0V to VCC | 100 | — | — | mA |
| VIH | Input HIGH Voltage | Guaranteed Logic HIGH Level | 2.0 | — | — | V |
| VIL | Input LOW Voltage | Guaranteed Logic LOW Level | -0.5 | — | 0.8 | V |
| IiH | Input HIGH Current | VCC = Max., VIN = VCC | — | — | ±1 | μA |
| IiL | Input LOW Current | VCC = Max., VIN = GND | — | — | ±1 | μA |
| ICC | Quiescent Supply Current | VCC = 5.5V, Vin = 0V or Vcc | — | — | 1 | μA |

Dynamic Electrical Characteristics (Over the Operating Range, TA = -40°C to +85°C, VCC = 5V ±10%, GND = 0V)

| Parameters | Description | Test Conditions ⁽¹⁾ | Min. | Typ ⁽²⁾ | Max. | Units |
|--------------|---------------------------------|--|------|--------------------|------|------------|
| tON | Turn-on Time | VCOM = 3.0V, see Figure 1 | — | 10 | 20 | ns |
| tOFF | Turn-off Time | VCOM = 3.0V, see Figure 1 | — | 4 | 10 | ns |
| Q | Charge Injection ⁽²⁾ | CL = 0.5 nF, VGen = 0V, see Figure 4 | — | 3 | 5 | pC |
| C(OFF) | NC or NO Capacitance | f = 1 kHz | — | 13 | — | pF |
| CCOM(ON/OFF) | COM On Capacitance | f = 1 kHz (319A) | — | 45 | — | pF |
| CCOM(OFF) | COM Off Capacitance | f = 1 kHz (317A, 318A) | — | 13 | — | pF |
| OIRR | Off Isolation | RL = 100 Ω, f = 1 MHz, see Figure 2 | — | -72 | — | dB |
| BW | Bandwidth -3 dB | RL = 100 Ω (319A), see Figure 3 RL = 100 Ω (317A, 318A), see Figure 3 | — | 106 200 | — | MHz MHz |
| D | Distortion RFLAT/RL | RL = 100 Ω | — | 4 | — | % |

Notes:

1. For Max or Min. conditions, use appropriate value specified under Electrical Characteristics for applicable device type.
2. Guaranteed by design.

Single 3.3V Supply
DC Electrical Characteristics (Over the Operating Range, $T_A = -40^\circ\text{C}$ to $+85^\circ\text{C}$, $V_{CC} = 3.3\text{V} \pm 10\%$, $GND = 0\text{V}$)

| Parameters | Description | Test Conditions ⁽¹⁾ | Min. | Typ ⁽²⁾ | Max. | Units |
|-------------------------------|--------------------------|--|------|--------------------|----------|---------------|
| V_{ANALOG} | Analog Signal Range | | 0 | — | V_{CC} | V |
| R_{ON} | ON-Resistance | $I_{ON} = 10\text{ mA to }30\text{ mA}$ | — | 18 | 22 | Ω |
| $\Delta R_{ON}^{(3)}$ | Match Between Channels | | — | 1 | 3 | |
| $R_{FLAT(ON)}$ | R_{ON} Flatness | $I_{ON} = 1\text{ mA}$, V_{NO} , $V_{NC} = 0\text{V to }V_{CC}$ | — | 8.7 | 12.5 | |
| $I_{NO(OFF)}$ $I_{NC(ON)}$ | Off Leakage Current | V_{NO} , $V_{NC} = 3.0\text{V}$ | -80 | — | 80 | nA |
| $I_{COM(ON)}$ | On Leakage Current | V_{NO} , $V_{NC} = 3.0\text{V}$ | -80 | — | 80 | |
| I_O | Output Current | V_{NO} , V_{NC} or $V_{COM} = 0\text{V to }V_{CC}$ | 80 | — | — | mA |
| V_{IH} | Input HIGH Voltage | Guaranteed Logic HIGH Level | 2.0 | — | — | V |
| V_{IL} | Input LOW Voltage | Guaranteed Logic LOW Level | -0.5 | — | 0.8 | |
| I_{IH} | Input HIGH Current | $V_{CC} = \text{Max.}$, $V_{IN} = V_{CC}$ | — | — | ± 1 | μA |
| I_{IL} | Input LOW Current | $V_{CC} = \text{Max.}$, $V_{IN} = GND$ | — | — | ± 1 | |
| I_{CC} | Quiescent Supply Current | $V_{CC} = \text{Max.}$, $V_{IN} = 0\text{V or }V_{CC}$ | — | — | 1 | |

Dynamic Electrical Characteristics (Over the Operating Range, $T_A = -40^\circ\text{C}$ to $+85^\circ\text{C}$, $V_{CC} = 3.3\text{V} \pm 10\%$, $GND = 0\text{V}$)

| Parameters | Description | Test Conditions ⁽¹⁾ | Min. | Typ ⁽²⁾ | Max. | Units |
|-------------------|---------------------------------|--|------|--------------------|------|-------|
| t_{ON} | Turn-on Time | $V_{COM} = 3.0\text{V}$, see Figure 1 | — | 28 | 40 | ns |
| t_{OFF} | Turn-off Time | $V_{COM} = 3.0\text{V}$, see Figure 1 | — | 4 | 20 | ns |
| Q | Charge Injection ⁽²⁾ | $C_L = 1.0\text{ nF}$, $V_{Gen} = 0\text{V}$, see Figure 4 | — | 3 | 5 | pC |
| $C(OFF)$ | NC or NO Capacitance | $f = 1\text{ kHz}$ | — | 15 | — | pF |
| $C_{COM(ON/OFF)}$ | COM On/Off Capacitance | $f = 1\text{ kHz}$ (319) | — | 50 | — | pF |
| $C_{COM(OFF)}$ | COM Off Capacitance | $f = 1\text{ kHz}$ (317, 318) | — | 15 | — | pF |
| OIRR | Off Isolation | $R_L = 100\ \Omega$, $f = 1\text{ MHz}$, see Figure 2 | — | 72 | — | dB |
| BW | Bandwidth -3 dB | $R_L = 100\ \Omega$ (319), see Figure 3 | — | 90 | — | MHz |
| | | $R_L = 100\ \Omega$ (317, 318), see Figure 3 | — | 200 | — | MHz |
| D | Distortion | $R_L = 100\ \Omega$ | — | 4 | — | % |

Notes:

1. For Max. or Min. conditions, use appropriate value specified under Electrical Characteristics for applicable device type.
2. Guaranteed by design.

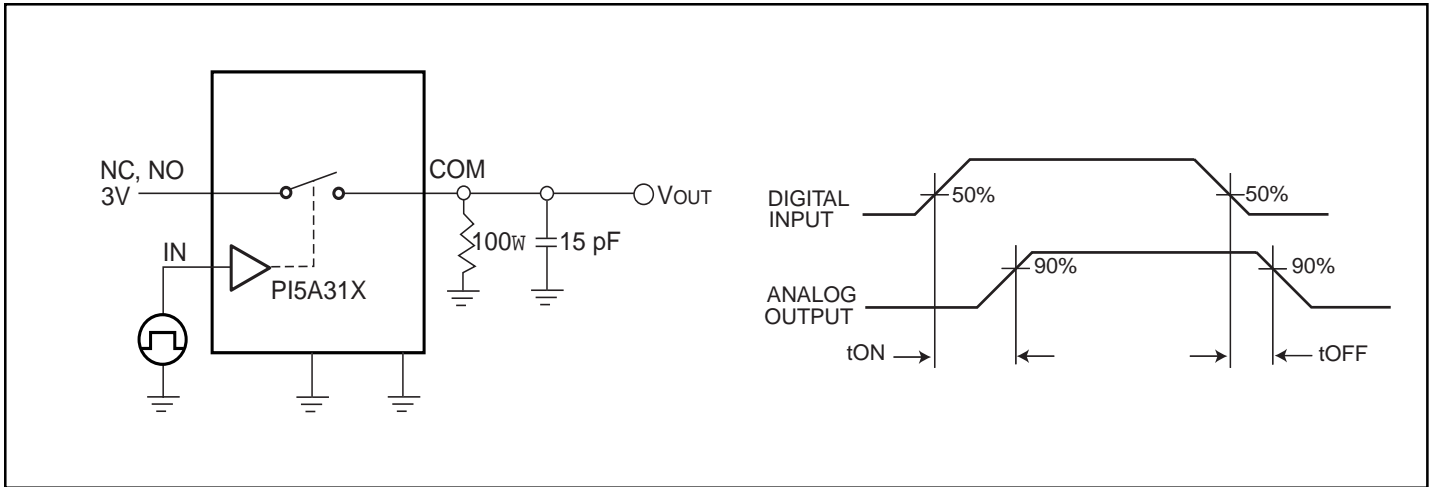
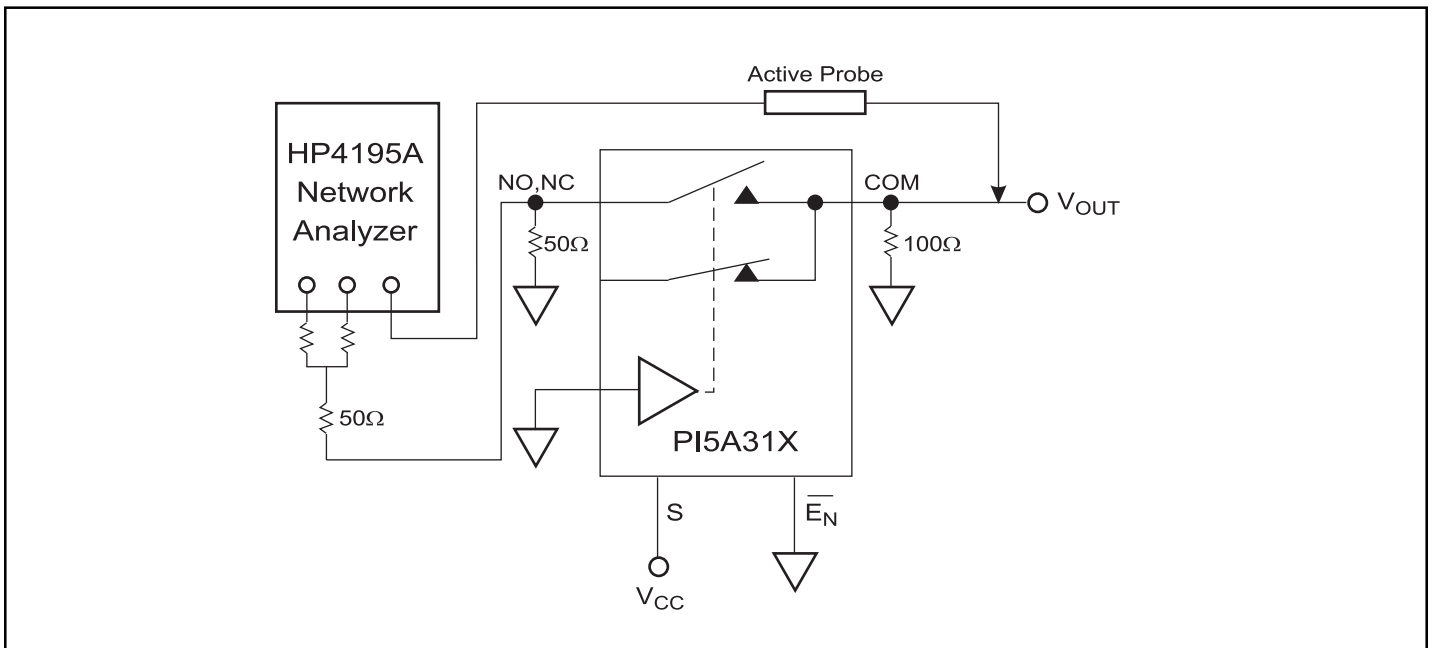
Test Circuits

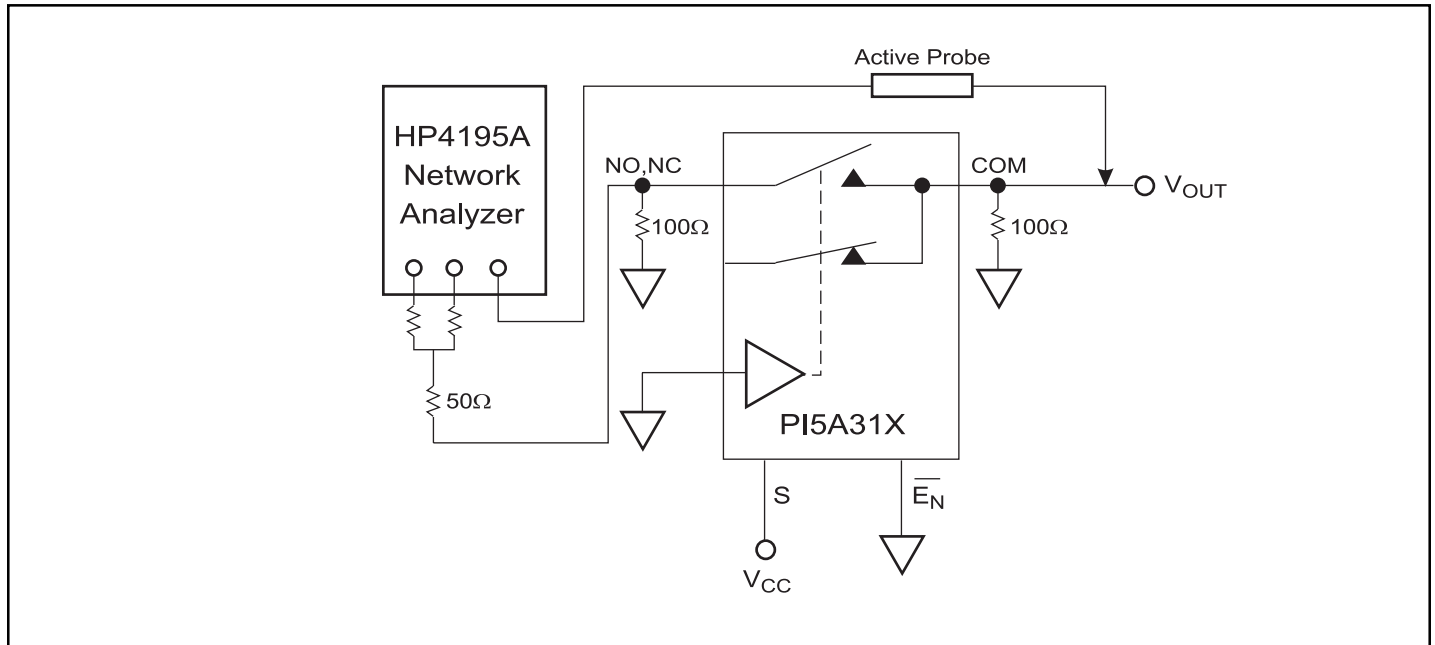
Figure 1. Switching Time

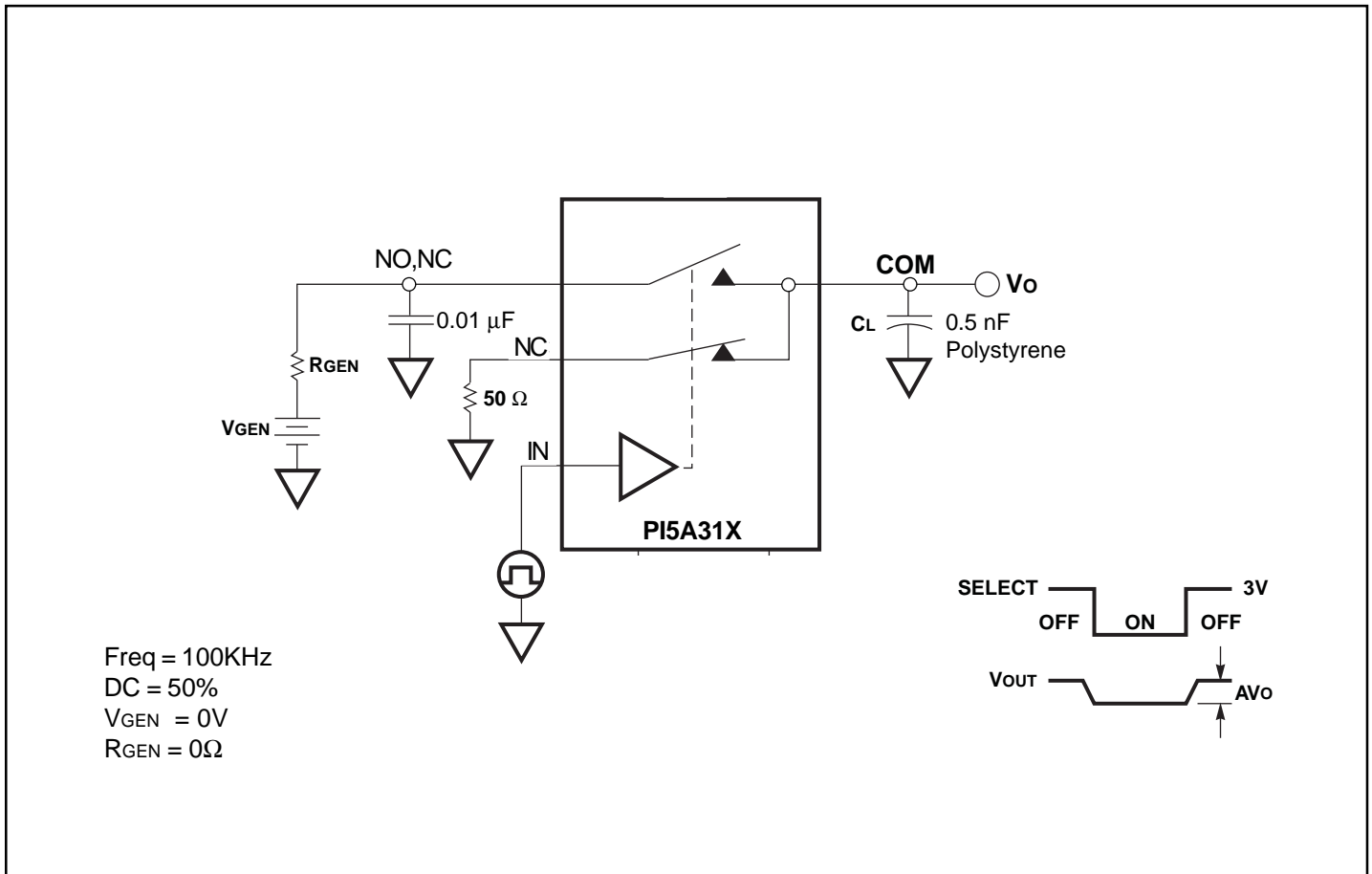
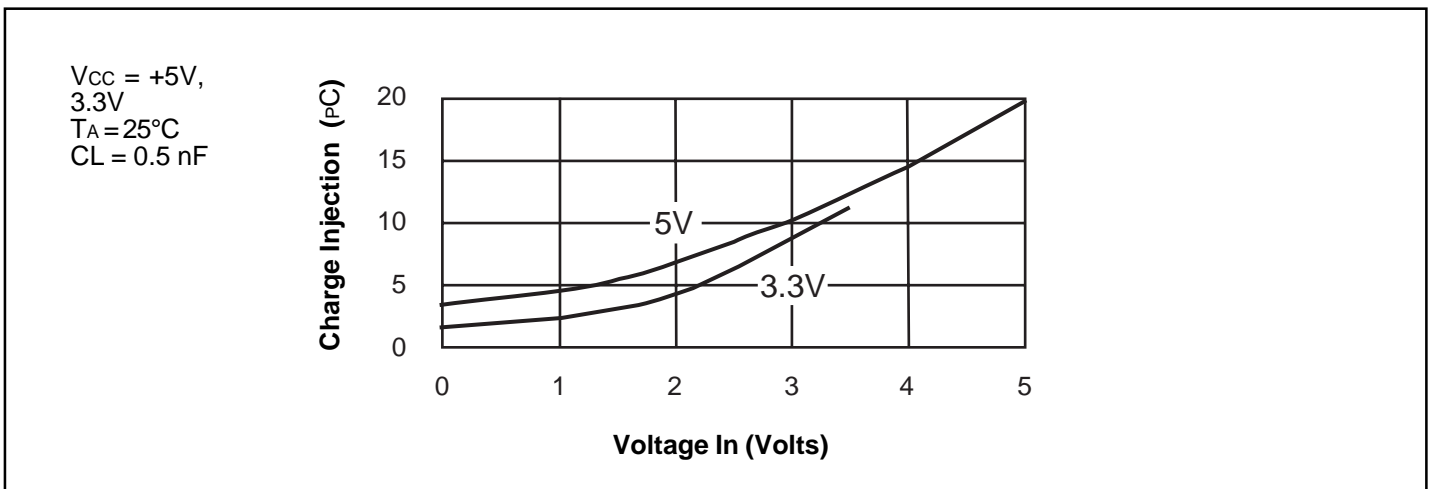
Figure 2. Off Isolation

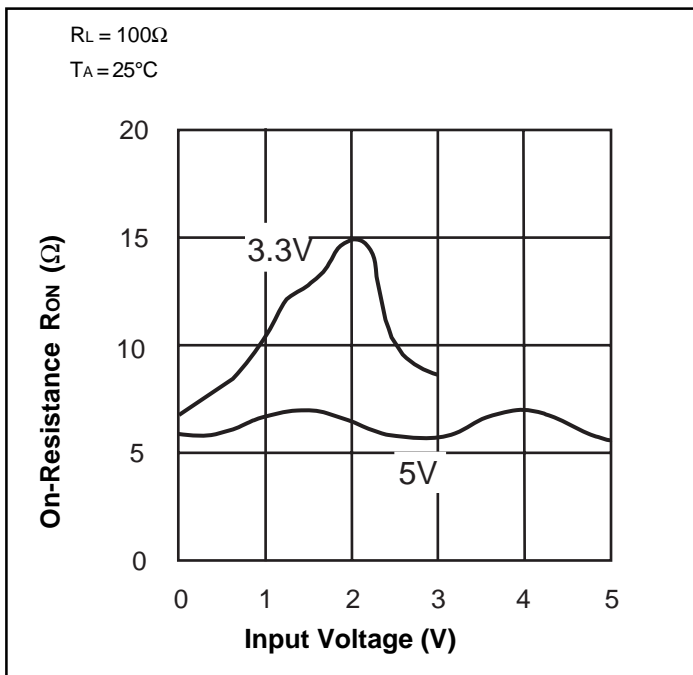
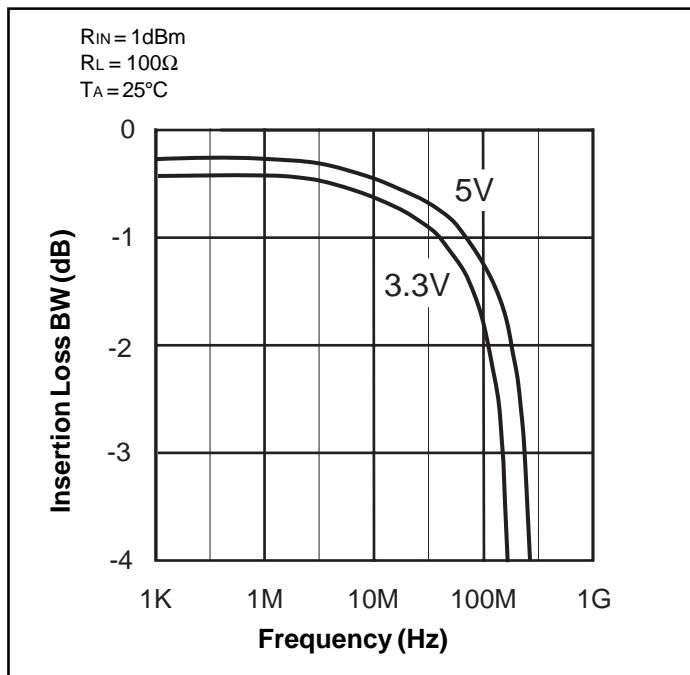
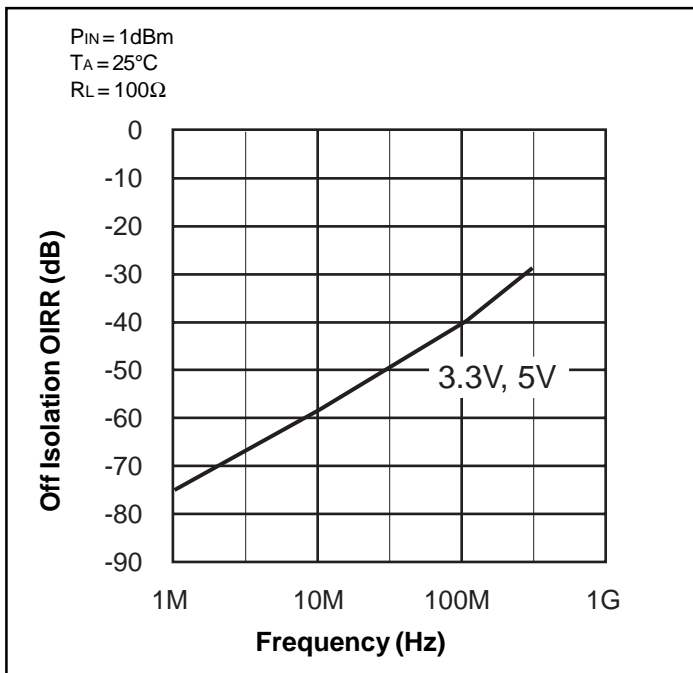
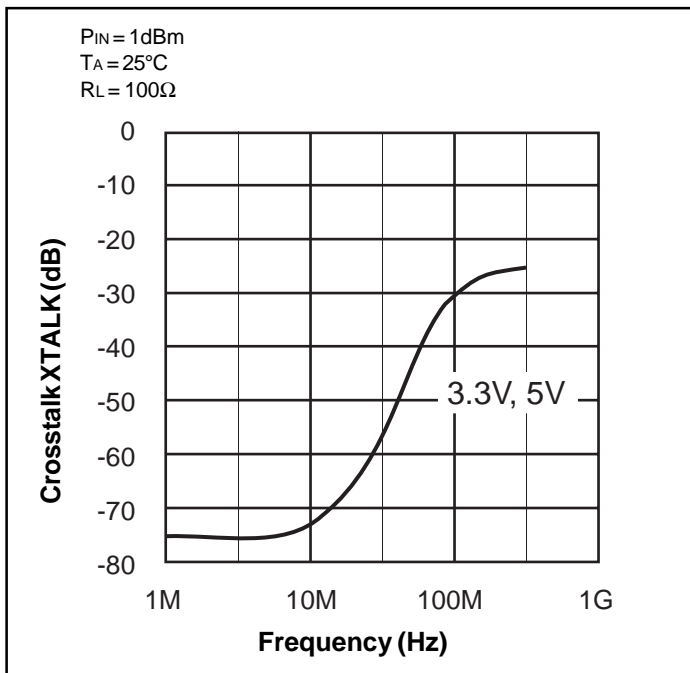
Typical Operating Characteristics

Figure 3. Bandwidth

Figure 5. Charge Injection

Figure 6. Charge Injection vs Analog Voltage

Figure 7. On-Resistance vs. Input Voltage

Figure 8. Insertion Loss vs. Frequency

Figure 9. Off Isolation vs. Frequency

Figure 10. Crosstalk vs Frequency