

FEATURES

Single-chip audio/video/data switching solution

Wide bandwidth section

Rail-to-rail signal switching capability

Compliant with full speed USB 2.0 signaling (3.6 V p-p)

Compliant with high speed USB 2.0 signaling (400 mV p-p)

Supports USB data rates up to 480 Mbps

550 MHz, 3 dB bandwidth

Low R_{ON} : 5.9 Ω typical

Excellent matching between channels

Low distortion section

Low R_{ON} : 3.9 Ω typical

230 MHz, 3 dB bandwidth (SPDT)

160 MHz, 3 dB bandwidth (4:1 multiplexers)

Single-supply operation: 1.65 V to 3.6 V

Typical power consumption: <0.1 μ W

Pb-free packaging: 30-ball WLCSP (3 mm \times 2.5 mm)

APPLICATIONS

Cellular phones

PMPs

MP3 players

Audio/video/data/USB switching

GENERAL DESCRIPTION

The ADG790 is a single-chip, CMOS switching solution that comprises four SPDT switches and two 4:1 multiplexers. The internal architecture of the device provides two switching sections, a wide bandwidth section and a low distortion section.

The wide bandwidth section contains three SPDT switches that exhibit low on resistance with excellent flatness and channel matching. This, combined with wide bandwidth, makes the three-SPDT-switch configuration ideal for high frequency signals, such as full speed (12 Mbps) and high speed (480 Mbps) USB signals and high resolution video signals.

The low distortion section contains a single SPDT switch and two 4:1 multiplexers that exhibit very low on resistance and excellent flatness, making these switches ideal for a wide range of applications, including low distortion audio applications and low resolution video (CVBS and S-Video) applications.

FUNCTIONAL BLOCK DIAGRAM

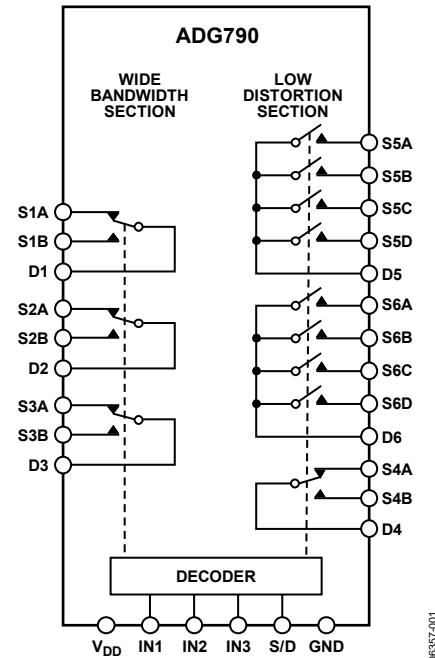

Figure 1.

All switches conduct equally well in both directions when on and block signals up to the supply rails when off. A 4-wire parallel interface controls the operation of the device and allows the user to control switches from both sections simultaneously. This simplifies the design and provides a cost-effective, single-chip switching solution for portable devices where multiple signals share a single port connector. The shutdown (S/D) pin allows the user to disable all four SPDT switches and force the 4:1 multiplexers into the S5B and S6B positions, respectively.

The ADG790 is packaged in a compact, 30-ball WLCSP (6 \times 5 ball array) with a total area of 7.5 mm² (3 mm \times 2.5 mm). This tiny package size and its low power consumption make the ADG790 an ideal solution for portable devices.

Rev. 0

Information furnished by Analog Devices is believed to be accurate and reliable. However, no responsibility is assumed by Analog Devices for its use, nor for any infringements of patents or other rights of third parties that may result from its use. Specifications subject to change without notice. No license is granted by implication or otherwise under any patent or patent rights of Analog Devices. Trademarks and registered trademarks are the property of their respective owners.

One Technology Way, P.O. Box 9106, Norwood, MA 02062-9106, U.S.A.

Tel: 781.329.4700

Fax: 781.461.3113

www.analog.com

©2007 Analog Devices, Inc. All rights reserved.

TABLE OF CONTENTS

Features	1	Test Circuits.....	11
Applications.....	1	Theory of Operation	13
Functional Block Diagram	1	Wide Bandwidth Section.....	13
General Description	1	Low Distortion Section.....	13
Revision History	2	Control Interface	13
Specifications.....	3	Evaluation Board	14
Absolute Maximum Ratings.....	5	Using the ADG790 Evaluation Board	14
ESD Caution.....	5	Outline Dimensions	17
Pin Configuration and Function Descriptions.....	6	Ordering Guide	17
Terminology	7		
Typical Performance Characteristics	8		

REVISION HISTORY

1/07—Revision 0: Initial Version

SPECIFICATIONS

$V_{DD} = 2.7\text{ V to }3.6\text{ V}$, $GND = 0\text{ V}$, $T_A = -40^\circ\text{C to }+85^\circ\text{C}$, all switch sections unless otherwise noted.

Table 1.

Parameter	Symbol	Test Conditions/Comments	Min	Typ ¹	Max	Unit
ANALOG SWITCH						
Analogue Signal Range			0		V_{DD}	V
On Resistance	R_{ON}	$V_{DD} = 2.7\text{ V}$, $V_S = 0\text{ V to }V_{DD}$, $I_{DS} = 10\text{ mA}$ (see Figure 18)		5.9	8.8	Ω
		Wide bandwidth section ²		3.9	5.5	Ω
		Low distortion section ³				
On Resistance Flatness	$R_{FLAT(ON)}$	$V_{DD} = 2.7\text{ V}$, $V_S = 0\text{ V to }V_{DD}$, $I_{DS} = 10\text{ mA}$ (see Figure 18)		2.0	3.6	Ω
		Wide bandwidth section ²		0.74	1.6	Ω
		Low distortion section ³				
On Resistance Matching Between Channels ⁴	ΔR_{ON}	$V_{DD} = 2.7\text{ V}$, $V_S = 0\text{ V to }V_{DD}$, $I_{DS} = 10\text{ mA}$				
		Wide bandwidth section ²			0.52	Ω
		Low distortion section ³ (SPDT)			0.1	Ω
		Low distortion section ³ (4:1 multiplexers)			0.3	Ω
LEAKAGE CURRENTS						
Source Off Leakage	I_S (OFF)	$V_{DD} = 3.6\text{ V}$, $V_S = 0\text{ V or }3.6\text{ V}$, $V_D = 3.6\text{ V or }0\text{ V}$ (see Figure 19)		± 10		nA
Channel On Leakage	I_D, I_S (ON)	$V_{DD} = 3.6\text{ V}$, $V_S = V_D = 0\text{ V or }3.6\text{ V}$ (see Figure 20)		± 10		nA
DIGITAL INPUTS (IN1, IN2, IN3, S/D)						
Input High Voltage	V_{INH}		2.0			V
Input Low Voltage	V_{INL}				0.8	V
Input High/Input Low Current	I_{INL}, I_{INH}	$V_{IN} = V_{INL}$ or V_{INH}		± 0.005	± 0.1	μA
Digital Input Capacitance	C_{IN}			6		pF
DYNAMIC CHARACTERISTICS⁵						
t_{ON}	t_{ON}	$R_L = 50\ \Omega$, $C_L = 35\text{ pF}$, $V_S = V_{DD}/2$ or 0 V (see Figure 24)		20	32	ns
t_{OFF}	t_{OFF}	$R_L = 50\ \Omega$, $C_L = 35\text{ pF}$, $V_S = V_{DD}/2$ or 0 V (see Figure 24)		9	15	ns
Propagation Delay	t_D	$R_L = 50\ \Omega$, $C_L = 35\text{ pF}$				
		Wide bandwidth section ²		0.3	0.46	ns
		Low distortion section ³ (SPDT)		0.65	0.95	ns
		Low distortion section ³ (4:1 multiplexers)		0.4	0.65	ns
Propagation Delay Skew	t_{SKEW}	$R_L = 50\ \Omega$, $C_L = 35\text{ pF}$				
		Wide bandwidth section ²		20		ps
		Low distortion section ³ (4:1 multiplexers)		40		ps
Break-Before-Make Time Delay	t_{BBM}	$R_L = 50\ \Omega$, $C_L = 35\text{ pF}$, $V_{S1} = V_{S2} = V_{DD}/2$ (see Figure 25)	5	11		ns
Charge Injection	Q_{INJ}	$V_S = 0\text{ V}$, $R_S = 0\ \Omega$, $C_L = 1\text{ nF}$ (see Figure 26)				
		Wide bandwidth section ²		-0.57		pC
		Low distortion section ³		6.2		pC
Off Isolation		$R_L = 50\ \Omega$, $C_L = 5\text{ pF}$, $f = 1\text{ MHz}$ (see Figure 21)		-74		dB
Channel-to-Channel Crosstalk		$R_L = 50\ \Omega$, $C_L = 5\text{ pF}$, $f = 1\text{ MHz}$ (see Figure 22)		-77		dB
Total Harmonic Distortion	THD + N	$R_L = 32\ \Omega$, $f = 20\text{ Hz to }20\text{ kHz}$, $V_S = 2\text{ V p-p}$				
		Wide bandwidth section ²		1.2		%
		Low distortion section ³		0.65		%
-3 dB Bandwidth		$R_L = 50\ \Omega$, $C_L = 5\text{ pF}$ (see Figure 23)				
		Wide bandwidth section ²		550		MHz
		Low distortion section ³ (SPDT)		230		MHz
		Low distortion section ³ (4:1 multiplexers)		160		MHz
Differential Gain Error		CCIR330 test signal				
		Wide bandwidth section ²		0.07		%
		Low distortion section ³ (SPDT)		0.08		%
		Low distortion section ³ (4:1 multiplexers)		0.18		%

ADG790

Parameter	Symbol	Test Conditions/Comments	Min	Typ ¹	Max	Unit
Differential Phase Error		CCIR330 test signal				
		Wide bandwidth section ²		0.13		Degrees
		Low distortion section ³ (SPDT)		0.08		Degrees
Power Supply Rejection Ratio	PSRR	Low distortion section ³ (4:1 multiplexers)		0.19		Degrees
		f= 10 kHz, no decoupling capacitors		-90		dB
Source Off Capacitance	C _S (OFF)	Wide bandwidth section ²		3.5		pF
		Low distortion section ³		11		pF
Drain Off Capacitance	C _D (OFF)	Wide bandwidth section ²		5.5		pF
		Low distortion section ³ (SPDT)		14		pF
Source/Drain On Capacitance	C _D , C _S (ON)	Wide bandwidth section ²		8.5		pF
		Low distortion section ³ (SPDT)		19		pF
		Low distortion section ³ (4:1 multiplexers)		32		pF
POWER REQUIREMENTS						
Supply Voltage	V _{DD}		1.65		3.6	V
Supply Current	I _{DD}	V _{DD} = 3.6 V, digital inputs tied to 0 V or 3.6 V		0.1	1	μA

¹ All typical values are at T_A = 25°C, V_{DD} = 3.3 V.

² Refers to all switches connected to Pin D1, Pin D2, and Pin D3.

³ Refers to all switches connected to Pin D4 (SPDT), Pin D5, and Pin D6 (4:1 multiplexers).

⁴ Refers to the on resistance matching between the same channels (S_xA and S_xB, for example) from different multiplexers for the wide bandwidth section and the 4:1 multiplexers from the low distortion section. For the SPDT switch from the low distortion section, it refers to the matching between the S4A and S4B channels.

⁵ Guaranteed by design; not subject to production test.

ABSOLUTE MAXIMUM RATINGS

$T_A = 25^\circ\text{C}$, unless otherwise noted.

Table 2.

Parameter	Rating
V_{DD} to GND	-0.3 V to +4.6 V
Analog and Digital Pins ¹	-0.3 V to $V_{DD} + 0.3$ V or 10 mA, whichever occurs first
Peak Current, S or D	100 mA (pulsed at 1 ms, 10% duty cycle maximum)
Continuous Current, S or D	30 mA
Operating Temperature Range	-40°C to +85°C
Storage Temperature Range	-65°C to +125°C
Junction Temperature	150°C
Thermal Impedance (θ_{JA}) ²	80°C/W
Reflow Soldering (Pb Free)	
Peak Temperature	260°C (+0°C/-5°C)
Time at Peak Temperature	As per JEDEC J-STD-20

¹ Overvoltages at IN, S, or D are clamped by internal diodes. Limit current to the maximum ratings given.

² Measured with the device soldered on a 4-layer board.

Stresses above those listed under Absolute Maximum Ratings may cause permanent damage to the device. This is a stress rating only; functional operation of the device at these or any other conditions above those indicated in the operational section of this specification is not implied. Exposure to absolute maximum rating conditions for extended periods may affect device reliability.

Only one absolute maximum rating can be applied at any one time.

ESD CAUTION



ESD (electrostatic discharge) sensitive device. Charged devices and circuit boards can discharge without detection. Although this product features patented or proprietary protection circuitry, damage may occur on devices subjected to high energy ESD. Therefore, proper ESD precautions should be taken to avoid performance degradation or loss of functionality.

PIN CONFIGURATION AND FUNCTION DESCRIPTIONS

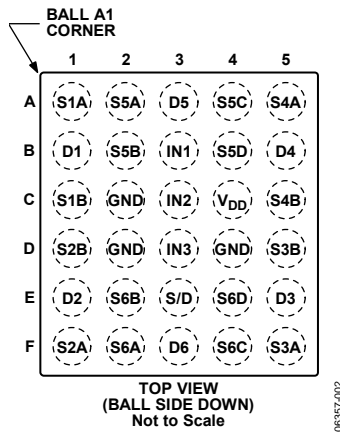

Figure 2. 30-Ball WLCSP (CB-30-1)

Table 3. Pin Function Descriptions

Ball Name	Mnemonic	Description
A1	S1A	Source Terminal for Mux 1 (Wide Bandwidth Section). Can be an input or an output.
A2	S5A	Source Terminal for Mux 5 (Low Distortion Section). Can be an input or an output.
A3	D5	Drain Terminal for Mux 5 (Low Distortion Section). Can be an input or an output.
A4	S5C	Source Terminal for Mux 5 (Low Distortion Section). Can be an input or an output.
A5	S4A	Source Terminal for Mux 4 (Low Distortion Section). Can be an input or an output.
B1	D1	Drain Terminal for Mux 1 (Wide Bandwidth Section). Can be an input or an output.
B2	S5B	Source Terminal for Mux 5 (Low Distortion Section). Can be an input or an output.
B3	IN1	Logic Control Input.
B4	S5D	Source Terminal for Mux 5 (Low Distortion Section). Can be an input or an output.
B5	D4	Drain Terminal for Mux 4 (Low Distortion Section). Can be an input or an output.
C1	S1B	Source Terminal for Mux 1 (Wide Bandwidth Section). Can be an input or an output.
C2	GND	Ground (0 V) Reference.
C3	IN2	Logic Control Input.
C4	V _{DD}	Most Positive Power Supply Terminal.
C5	S4B	Source Terminal for Mux 4 (Low Distortion Section). Can be an input or an output.
D1	S2B	Source Terminal for Mux 2 (Wide Bandwidth Section). Can be an input or an output.
D2	GND	Ground (0 V) Reference.
D3	IN3	Logic Control Input.
D4	GND	Ground (0 V) Reference.
D5	S3B	Source Terminal for Mux 3 (Wide Bandwidth Section). Can be an input or an output.
E1	D2	Drain Terminal for Mux 2 (Wide Bandwidth Section). Can be an input or an output.
E2	S6B	Source Terminal for Mux 6 (Low Distortion Section). Can be an input or an output.
E3	S/D	Shutdown Logic Control Input.
E4	S6D	Source Terminal for Mux 6 (Low Distortion Section). Can be an input or an output.
E5	D3	Drain Terminal for Mux 3 (Wide Bandwidth Section). Can be an input or an output.
F1	S2A	Source Terminal for Mux 2 (Wide Bandwidth Section). Can be an input or an output.
F2	S6A	Source Terminal for Mux 6 (Low Distortion Section). Can be an input or an output.
F3	D6	Drain Terminal for Mux 6 (Low Distortion Section). Can be an input or an output.
F4	S6C	Source Terminal for Mux 6 (Low Distortion Section). Can be an input or an output.
F5	S3A	Source Terminal for Mux 3 (Wide Bandwidth Section). Can be an input or an output.

TERMINOLOGY

I_{DD}

Positive supply current.

V_D (V_S)

Analog voltage on Terminal D and Terminal S.

R_{ON}

Ohmic resistance between Terminal D and Terminal S.

R_{FLAT} (ON)

Flatness is defined as the difference between the maximum and minimum value of on resistance as measured.

ΔR_{ON}

On resistance match between any two channels.

I_S (OFF)

Source leakage current with the switch off.

I_D, I_S (ON)

Channel leakage current with the switch on.

V_{INL}

Maximum input voltage for Logic 0.

V_{INH}

Minimum input voltage for Logic 1.

I_{INL} (I_{INH})

Input current of the digital input.

C_S (OFF)

Off switch source capacitance. Measured with reference to ground.

C_D, C_S (ON)

On switch capacitance. Measured with reference to ground.

C_{IN}

Digital input capacitance.

t_{ON}

Delay time between the 50% and the 90% points of the digital input and switch on condition.

t_{OFF}

Delay time between the 50% and the 10% points of the digital input and switch off condition.

t_{BBM}

On or off time measured between the 80% points of both switches when switching from one to the other.

t_D

Signal propagation delay through the switch measured between the 50% points of the input signal and its corresponding output signal.

t_{SKEW}

Difference in propagation delay between the selected inputs on the 4:1 multiplexers or any two SPDT switches from the wide bandwidth section.

Charge Injection

A measure of the glitch impulse transferred from the digital input to the analog output during on-off switching.

Off Isolation

A measure of unwanted signal coupling through an off switch.

Crosstalk

A measure of unwanted signal that is coupled through from one channel to another as a result of parasitic capacitance.

-3 dB Bandwidth

The frequency at which the output is attenuated by 3 dB.

Insertion Loss

The loss due to the on resistance of the switch.

THD + N

The ratio of the harmonic amplitudes plus signal noise to the fundamental.

Differential Gain Error

The measure of how much color saturation shift occurs when the luminance level changes. Both attenuation and amplification can occur; therefore, the largest amplitude change between any two levels is specified and expressed in percent.

Differential Phase Error

The measure of how much hue shift occurs when the luminance level changes. It can be a negative or a positive value and is expressed in degrees of subcarrier phase.

TYPICAL PERFORMANCE CHARACTERISTICS

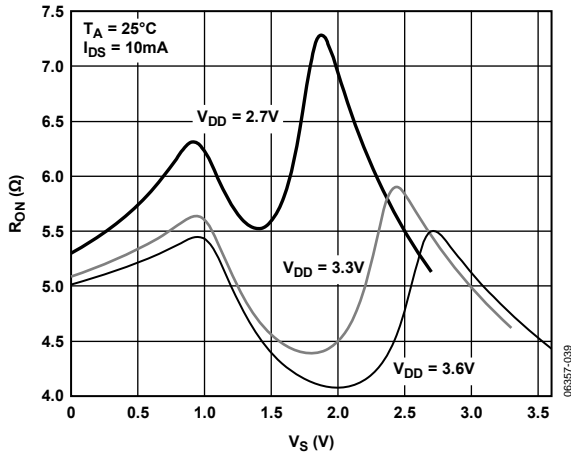

Figure 3. On Resistance vs. Source Voltage, Wide Bandwidth Section

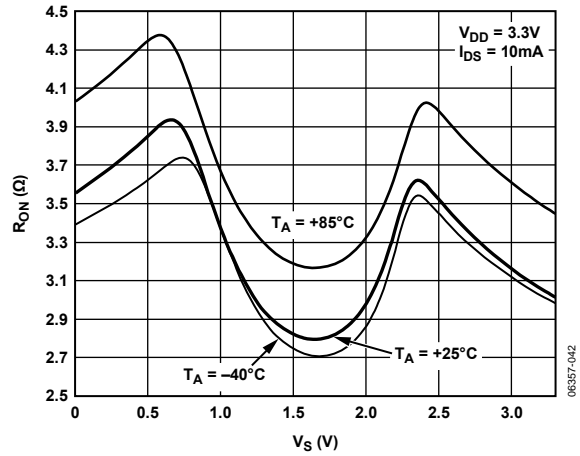

Figure 6. On Resistance vs. Temperature, Low Distortion Section

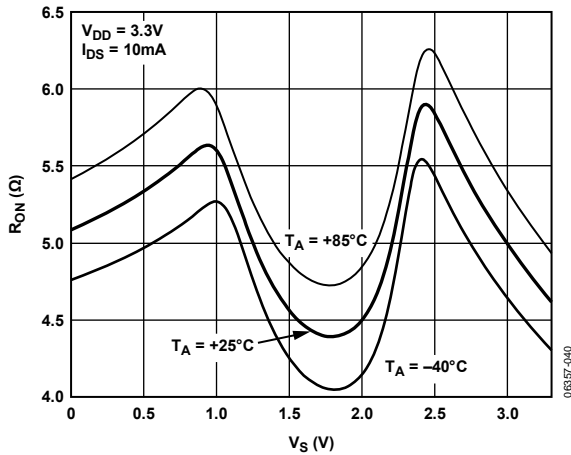

Figure 4. On Resistance vs. Temperature, Wide Bandwidth Section

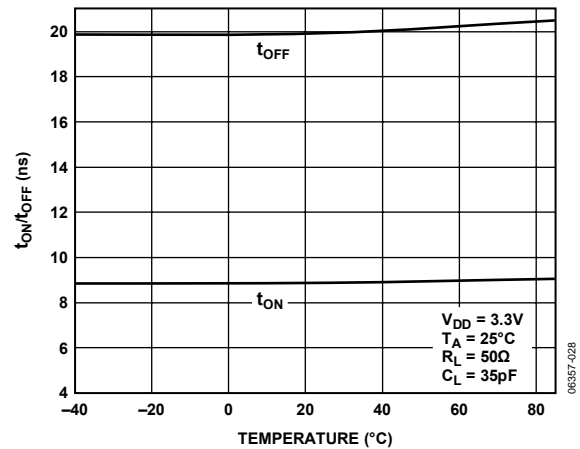

Figure 7. t_{ON}/t_{OFF} Times vs. Temperature

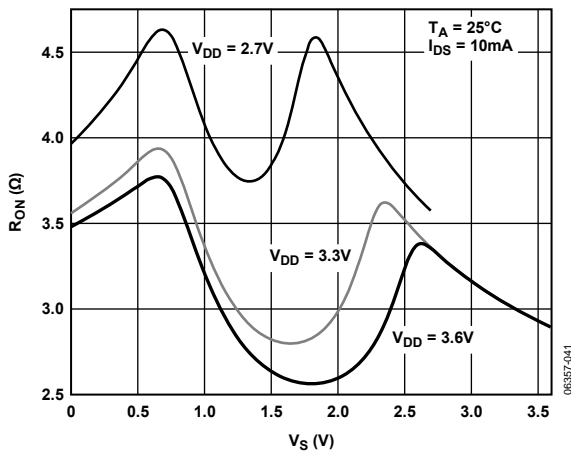

Figure 5. On Resistance vs. Source Voltage, Low Distortion Section

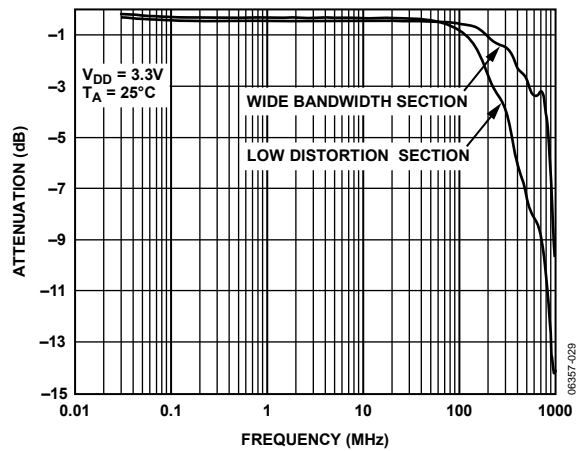

Figure 8. On Response vs. Frequency, Low Distortion Section (SPDT)

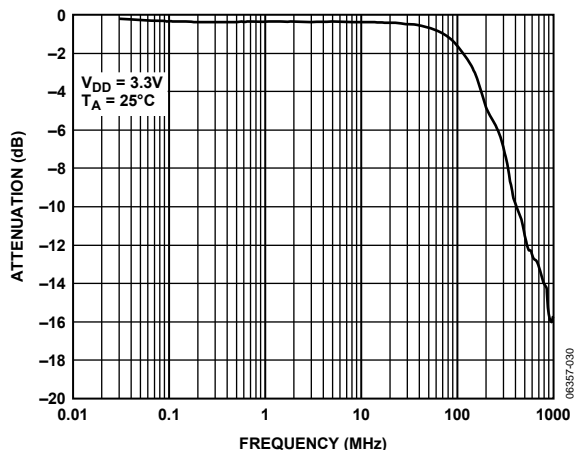

Figure 9. On Response vs. Frequency, Low Distortion Section (4:1 Multiplexers)

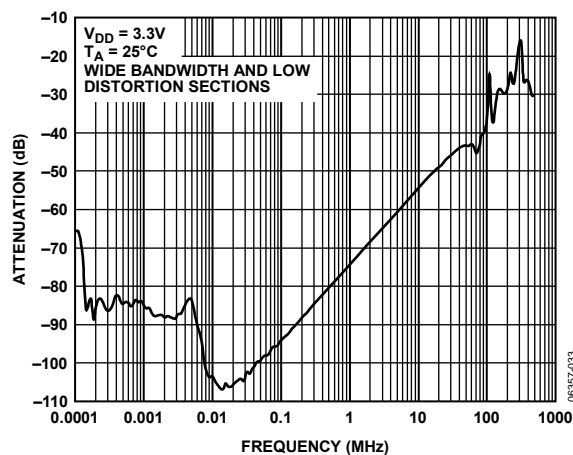

Figure 12. Off Isolation vs. Frequency

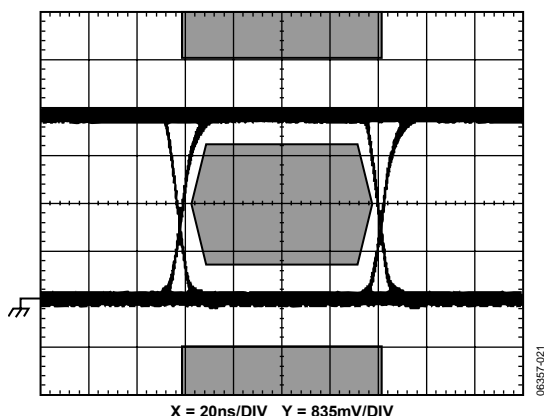

Figure 10. USB 1.1 Eye Diagram

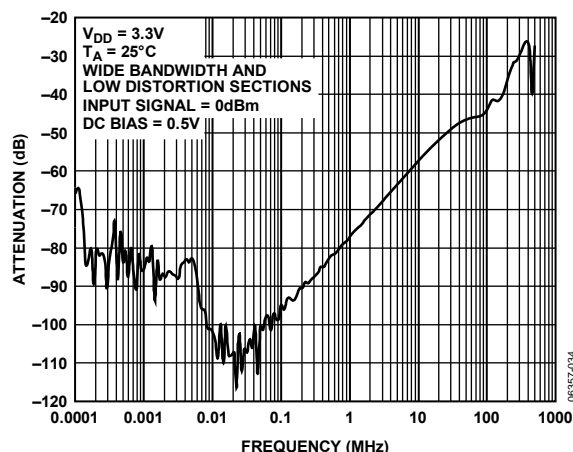

Figure 13. Crosstalk vs. Frequency

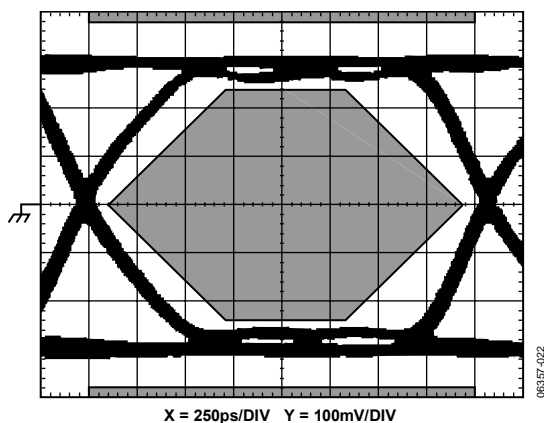

Figure 11. USB 2.0 Eye Diagram

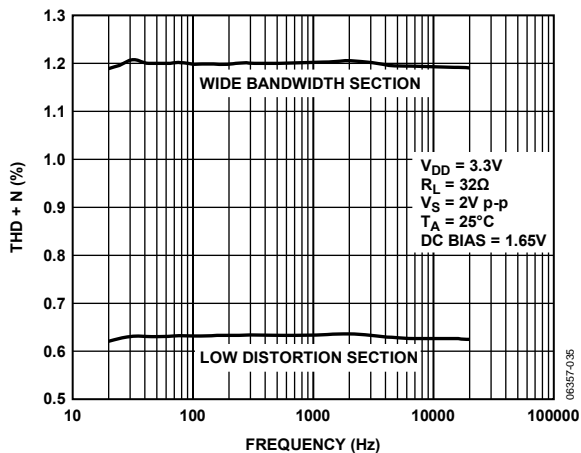

Figure 14. THD + N vs. Frequency

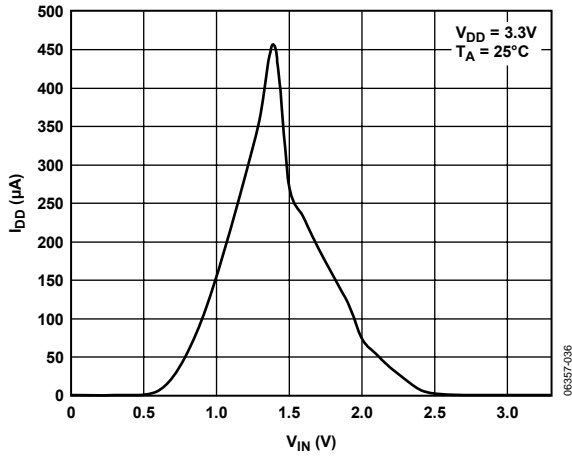

Figure 15. Supply Current vs. Input Logic Level

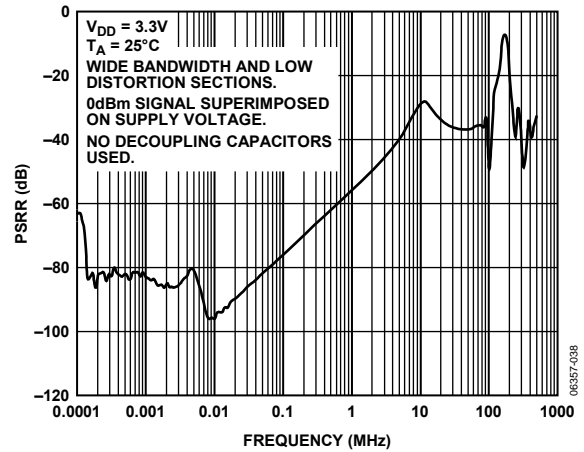

Figure 17. Power Supply Rejection Ratio vs. Frequency

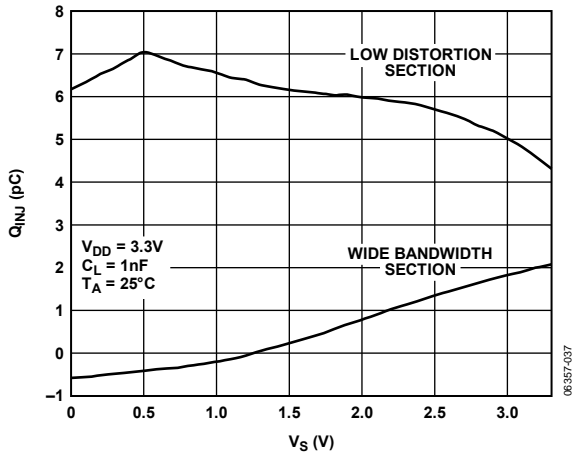

Figure 16. Charge Injection vs. Source Voltage

TEST CIRCUITS

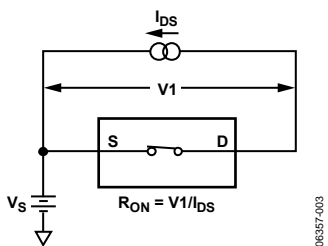

Figure 18. On Resistance

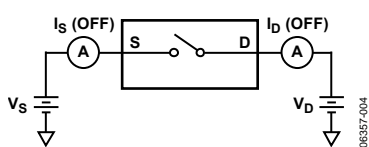

Figure 19. Off Leakage

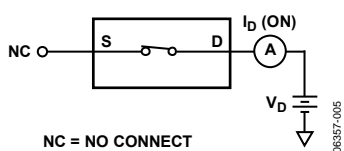
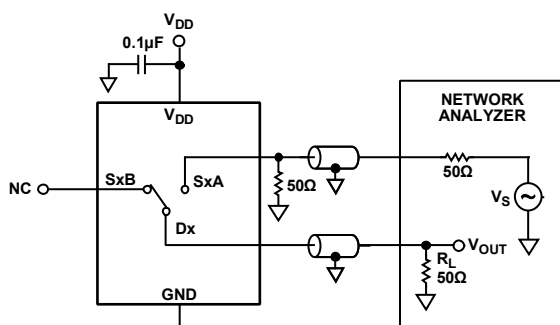

Figure 20. On Leakage



OFF ISOLATION = $20 \log \frac{V_{OUT}}{V_S}$

NC = NO CONNECT

Figure 21. Off Isolation

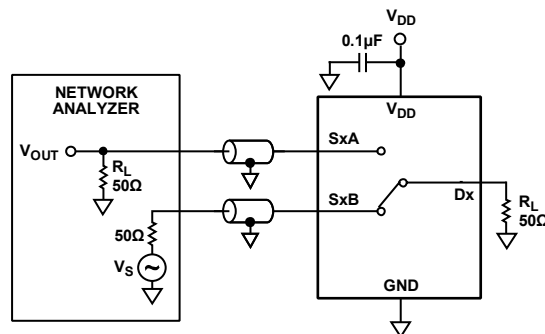

CHANNEL-TO-CHANNEL CROSSTALK = $20 \log \frac{V_{OUT}}{V_S}$

Figure 22. Channel-to-Channel Crosstalk

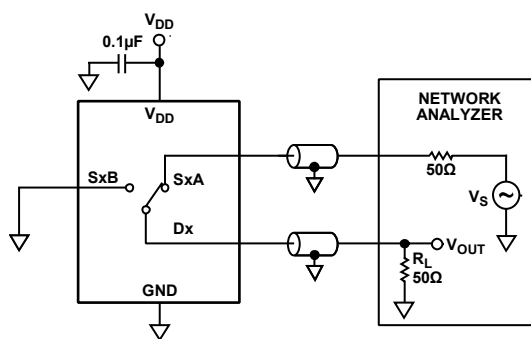

INSERTION LOSS = $20 \log \frac{V_{OUT \text{ WITH SWITCH}}}{V_{OUT \text{ WITHOUT SWITCH}}}$

Figure 23. -3 dB Bandwidth

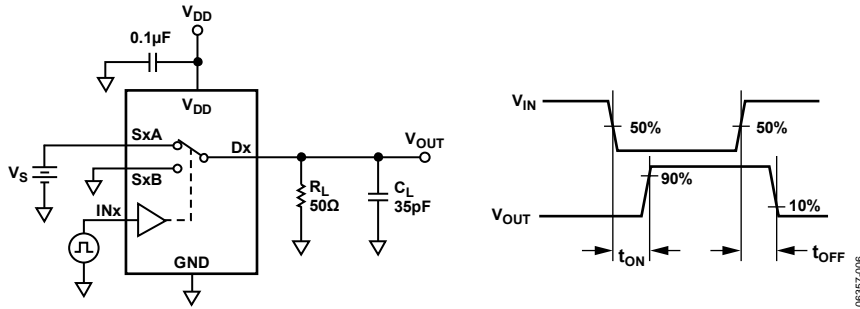

Figure 24. Switching Times (t_{ON} , t_{OFF})

06357-006

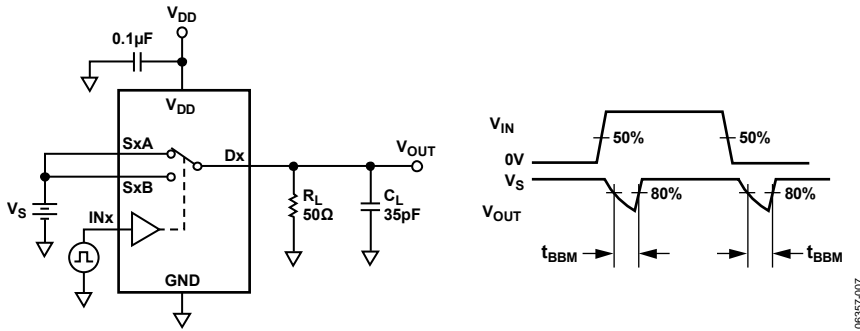
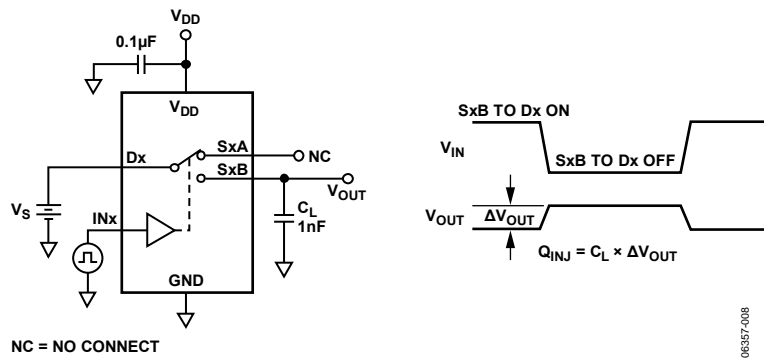

Figure 25. Break-Before-Make Time Delay (t_{BBM})

06357-007



NC = NO CONNECT

Figure 26. Charge Injection

06357-008

THEORY OF OPERATION

The ADG790 is a single-chip, CMOS switching solution that comprises four SPDT switches and two 4:1 multiplexers. The internal architecture used by the device groups the switches into two sections, each optimized to provide the best performance in terms of bandwidth and distortion. The on-chip parallel interface controls the operation of all switches, allowing the user to control switches from both sections simultaneously.

WIDE BANDWIDTH SECTION

The wide bandwidth section contains three SPDT switches S1A/S1B-D1, S2A/S2B-D2, and S3A/S3B-D3. These switches use a CMOS topology that ensures, besides low on resistance and excellent flatness, the ability to switch signals up to the supply rails. This, combined with the low switch capacitance, provides the wide bandwidth required when switching high frequency signals. The three SPDT switches are also optimized to provide low propagation delay and excellent matching between the channels, making the ADG790 ideal for applications that use multiple signals, such as universal USB switches (full and high speed), or RGB video signals, such as VGA.

LOW DISTORTION SECTION

The low distortion section contains a single SPDT switch (S4A/S4B-D4) and two 4:1 multiplexers (S5A/S5B/S5C/S5D-D5 and S6A/S6B/S6C/S6D-D6, respectively). The switches from this section also use a CMOS topology that exhibits very low on

resistance and flatness while maintaining a wide bandwidth that makes them suitable for a wide range of applications, including low distortion audio and standard definition video signals. The channels from the 4:1 multiplexers are matched to provide optimal performance when used with differential signals such as S-Video.

CONTROL INTERFACE

The operation of the ADG790 is controlled via a 4-wire parallel interface. The logic levels applied to the IN1, IN2, and IN3 pins control the operation of the switches from both the wide bandwidth and low distortion sections, as shown in Table 4. The shutdown pin (S/D) allows the user to disable all four SPDT switches and force the 4:1 multiplexers into the S5B and S6B positions, respectively. This function can be used to set up a low speed communication protocol between the circuitry from both sides of the device, which allows automatic configuration of the switching function.

For example, in modern handset applications, where a single connector is used as a multifunction communication port, the S5B-D5 and S6B-D6 configuration obtained by setting the S/D pin high can be used to detect the type of peripheral device connected to the handset. The ADG790 then automatically routes the required signals to the communication port connector.

Table 4. Truth Table

Logic Control Inputs				Switch Status						
S/D	IN1	IN2	IN3	S1A-D1 S2A-D2 S3A-D3 S5D-D5 S6D-D6	S1B-D1 S2B-D2 S3B-D3	S4A-D4	S4B-D4	S5A-D5 S6A-D6	S5B-D5 S6B-D6	S5C-D5 S6C-D6
1	X ¹	X ¹	X ¹	Off	Off	Off	Off	Off	On	Off
0	0	0	0	Off	On	Off	On	Off	Off	On
0	0	0	1	On	Off	On	Off	Off	Off	Off
0	0	1	0	Off	On	On	Off	Off	On	Off
0	0	1	1	Off	On	On	Off	Off	Off	On
0	1	0	0	Off	On	On	Off	On	Off	Off
0	1	0	1	On	Off	Off	On	Off	Off	Off
0	1	1	0	Off	On	Off	On	On	Off	Off
0	1	1	1	Off	On	Off	On	Off	On	Off

¹ X = logic state doesn't matter.

EVALUATION BOARD

The ADG790 evaluation board allows designers to evaluate the high performance of the device with a minimum of effort.

The EVAL-ADG790 includes a printed circuit board populated with the ADG790; it can be used to evaluate the performance of the device. It interfaces to the USB port of a PC, allowing the user to easily program the ADG790 through the USB port using the software provided with the board. Schematics of the evaluation board are shown in Figure 27 and Figure 28. The software runs on any PC that has Microsoft® Windows® 2000 or Windows® XP installed.

USING THE ADG790 EVALUATION BOARD

The ADG790 evaluation board is a test system designed to simplify the evaluation of the device. Each input/output of the part comes with a standardized socket to allow connection to and from USB, CVBS, S-Video, and VGA signal sources. A data sheet for the ADG790 evaluation board is also available with full information on setup and operation.

OUTLINE DIMENSIONS

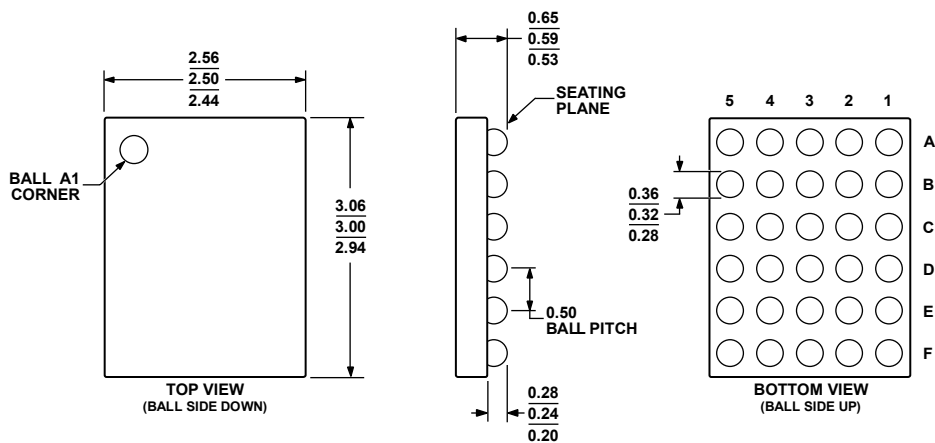

Figure 29. 30-Ball Wafer Level Chip Scale Package [WLCSP] (CB-30-1)

Dimensions shown in millimeters

082106-A

ORDERING GUIDE

Model	Temperature Range	Package Description	Package Option
ADG790BCBZ-REEL ¹	-40°C to +85°C	30-Ball Wafer Level Chip Scale Package [WLCSP]	CB-30-1
EVAL-ADG790EBZ ¹		Evaluation Board	

¹ Z = Pb-free part.

ADG790

NOTES

NOTES

ADG790

NOTES