

## ZXHF5000

### 4:2 IF switch with integrated gain and control

#### Summary

The ZXHF5000 provides an integrated IF solution for multiple output LNB and switch box applications. The ZXHF5000 includes a 4 by 2 switch with 19dB of positive gain which can be connected directly to the output of the LNB or switch box eliminating the need for cable drive amplifiers.

The ZXHF5000 includes all the control required for voltage and tone based systems providing a reliable and highly integrated solution.

For more information on the ZXHF5000 please contact your local Zetex sales office.

#### Features

- High linearity 4:2 switch
- Integrated cable drive amplifiers
- Integrated switch control - Tone and voltage
- Wide bandwidth 200 to 2700MHz
- Gain 19dB, rising across band
- High isolation Typ. >30dB, 200 to 2150MHz
- OIP3 >15dBm, 200 to 2150MHz
- Reliable tone detector with unwanted signal rejection filter
- Accurate voltage detector 14.0V to 15.5V
- Intelligent low power mode
- 3.3V operation
- Unconditionally stable
- Pin-out programmable for double-sided assembly

#### Applications

- Twin universal LNB's
- Quad universal LNB's
- Multiple output LNB's
- Multi switches

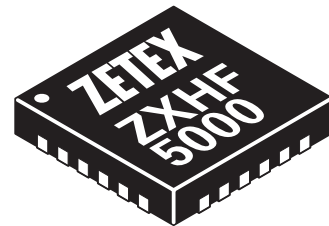
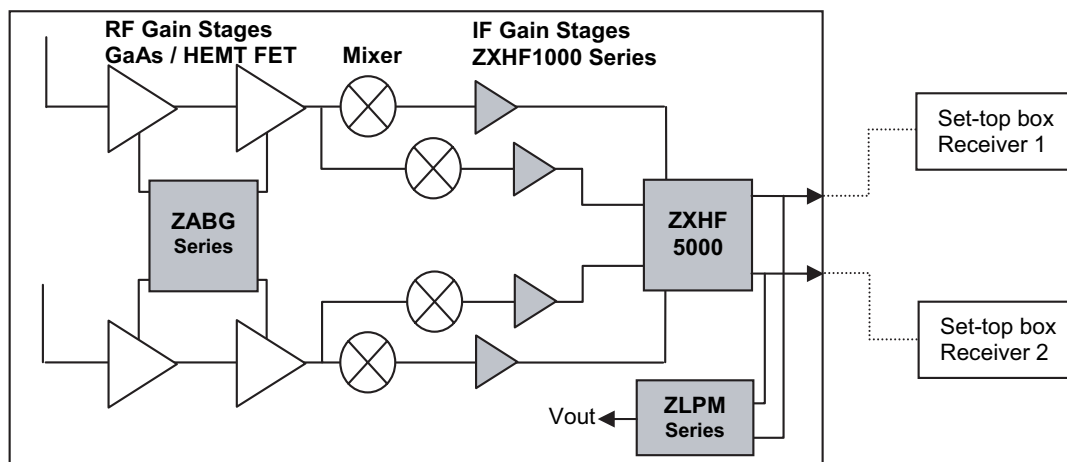

Figure 1 Typical low power twin universal LNB system



## Notes:

---

<b>Europe</b>	<b>Americas</b>	<b>Asia Pacific</b>	<b>Corporate Headquarters</b>
Zetex GmbH Kustermann-park Balanstraße 59 D-81541 München Germany Telefon: (49) 89 45 49 49 0 Fax: (49) 89 45 49 49 49 europe.sales@zetex.com	Zetex Inc 700 Veterans Memorial Highway Hauppauge, NY 11788 USA Telephone: (1) 631 360 2222 Fax: (1) 631 360 8222 usa.sales@zetex.com	Zetex (Asia Ltd) 3701-04 Metroplaza Tower 1 Hing Fong Road, Kwai Fong Hong Kong Telephone: (852) 26100 611 Fax: (852) 24250 494 asia.sales@zetex.com	Zetex Semiconductors plc Zetex Technology Park, Chadderton Oldham, OL9 9LL United Kingdom Telephone: (44) 161 622 4444 Fax: (44) 161 622 4446 hq@zetex.com

---

For international sales offices visit [www.zetex.com/offices](http://www.zetex.com/offices)

Zetex products are distributed worldwide. For details, see [www.zetex.com/salesnetwork](http://www.zetex.com/salesnetwork)

This publication is issued to provide outline information only which (unless agreed by the company in writing) may not be used, applied or reproduced for any purpose or form part of any order or contact or be regarded as a representation relating to the products or services concerned. The company reserves the right to alter without notice the specification, design, price or conditions of supply of any product or service.

---

**Issue 1 - October 2006**

**2**

**[www.zetex.com](http://www.zetex.com)**

**Zetex reserves the right to alter, without notice, the specifications, design or conditions of this product.**

© Zetex Semiconductors plc 2006