

FSUSB31

Low-Power 1-Port Hi-Speed USB 2.0 (480Mbps) Switch

Features

- Low On capacitance, 3.7pF (typical)
- Low On resistance, 6.5Ω (typical)
- Low power consumption (1μA maximum)
 - 10μA maximum I_{CCT} over and expanded control voltage range ($V_{IN} = 2.6V$, $V_{CC} = 4.3V$)
- Wide -3dB bandwidth, > 720MHz
- 8K I/O to GND ESD protection
- Power OFF protection when $V_{CC} = 0V$, D+ / D- pins can tolerate up to 4.3V
- Packaged in:
 - Pb-Free 8-lead MicroPak™ (1.6 x 1.6mm)
 - Pb-Free 8-lead US8

Applications

- Cell phone, PDA, Digital Camera, and Notebook
- LCD Monitor, TV, and Set-Top Box

Related Application Notes

- [AN-6022 Using the FSUSB30/31 to Comply with USB 2.0 Fault Condition Requirements](#)

Description

The FSUSB31 is a low-power, single-port, high-speed USB 2.0 switch. This part is configured as a single pole, single-throw switch and is optimized for switching or isolating a high-speed (480Mbps) source or a high-speed and full-speed (12Mbps) source. The FSUSB31 is compatible with the requirements of USB2.0 and features an extremely low on capacitance (C_{ON}) of 3.7pF. The wide bandwidth of this device (>720MHz) exceeds the bandwidth needed to pass the third harmonic, resulting in signals with minimum edge and phase distortion. Superior channel-to-channel crosstalk minimizes interference.

The FSUSB31 contains special circuitry on the D+ / D- pins that allows the device to withstand an over-voltage condition. This device is also designed to minimize current consumption even when the control voltage applied to the OE pin is lower than the supply voltage (V_{CC}). This feature is especially valuable for ultra-portable applications such as cell phones, allowing for direct interface with the general purpose I/Os of the baseband processor. Other applications include port isolation and switching in portable cell phones, PDAs, digital cameras, printers, and notebook computers.

Ordering Information

Part Number	Package	Pb-Free	Package Description
FSUSB31K8X	MAB08A	Yes	8-Lead US8, JEDEC MO-187, Variation CA 3.1mm Wide
FSUSB31L8X	MAC08A	Yes	8-Lead MicroPak, 1.6mm Wide

Pb-Free package per JEDEC J-STD-020B.

Application Diagram

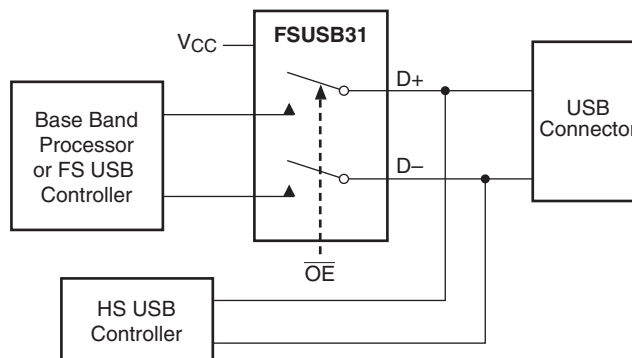

Figure 1. Typical Application Diagram

MicroPak™ is a trademark of Fairchild Semiconductor Corporation.

Connection Diagrams

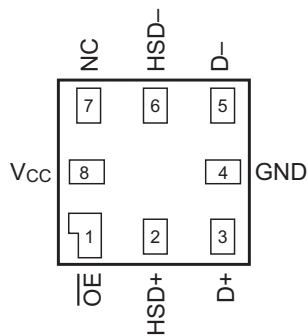

Figure 2. Pin Assignments for MicroPak

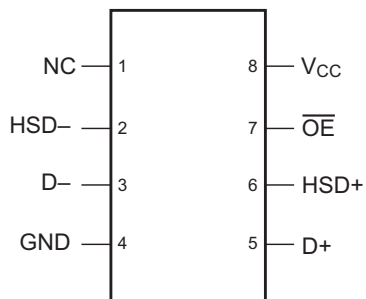

Figure 3. Pin Assignments for US8

Analog Symbol

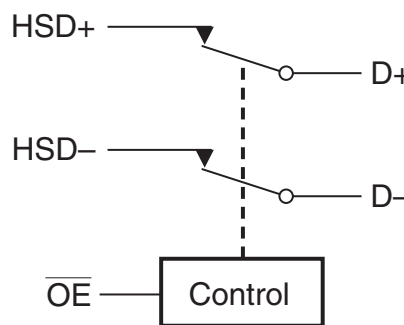

Figure 4. Analog Symbol

Pin Descriptions

Pin Name	Description
\overline{OE}	Bus Switch Enable
D+, D-, HSD+, HSD-	Data Ports
NC	No Connect

Truth Table

\overline{OE}	Function
HIGH	Disconnect
LOW	D+, D- = HSD

Absolute Maximum Ratings

Stresses exceeding the absolute maximum ratings may damage the device. The device may not function or be operable above the recommended operating conditions and stressing the parts to these levels is not recommended. In addition, extended exposure to stresses above the recommended operating conditions may affect device reliability. The absolute maximum ratings are stress ratings only.

Symbol	Parameter	Minimum	Maximum	Unit
V_{CC}	Supply Voltage	-0.5V	4.6	V
V_S	DC Input Voltage ⁽¹⁾	-0.5V	4.6	V
V_{IN}	DC Switch Voltage ⁽¹⁾	HSD	$V_{CC}+0.3$	V
		D+, D-	+4.6	V
I_{IK}	DC Input Diode Current	-50		mA
I_{OUT}	DC Output Current		50	mA
T_{STG}	Storage Temperature	-65	+150	°C
ESD	Human Body Model	All Pins	7.5	kV
		I/O to GND	8	kV

Recommended Operating Conditions

The Recommended Operating Conditions table defines the conditions for actual device operation. Recommended operating conditions are specified to ensure optimal performance to the datasheet specifications. Fairchild does not recommend exceeding them or designing to absolute maximum ratings.

Symbol	Parameter	Minimum	Maximum	Unit
V_{CC}	Supply Voltage	3.0	4.3	V
V_{IN}	Control Input Voltage ⁽²⁾	0V	V_{CC}	V
	Switch Input Voltage	0V	V_{CC}	V
T_A	Operating Temperature	-40	+85	°C

Notes:

1. The input and output negative voltage ratings may be exceeded if the input and output diode current ratings are observed. DC switch voltage may never exceed 4.6V.
2. Control input must be held HIGH or LOW and it must not float.

DC Electrical Characteristics

All typical values are at 25°C unless otherwise specified.

Symbol	Parameter	Conditions	V _{CC} (V)	T _A = -40°C to +85°C			Unit
				Min.	Typ.	Max.	
V _{IK}	Clamp Diode Voltage	I _{IN} = -18mA	3.0			-1.2	V
V _{IH}	Input Voltage HIGH		3.0 to 3.6	1.3			V
			4.3	1.7			
V _{IL}	Input Voltage LOW		3.0 to 3.6			0.5	V
			4.3			0.7	
I _{IN}	Control Input Leakage	V _{IN} = 0V to V _{CC}	4.3	-1.0		1.0	μA
I _{OZ}	OFF State Leakage	0 ≤ HSD ≤ V _{CC}	4.3	-2.0		2.0	μA
I _{OFF}	Power OFF Leakage Current (D+, D-)	V _{IN} = 0.0V to 4.3V, V _{CC} = 0V	0	-2.0		2.0	μA
R _{ON}	Switch On Resistance ⁽³⁾	V _{IN} = 0.4V, I _{ON} = -8mA	3.0		6.5	10.0	Ω
ΔR _{ON}	Delta R _{ON} ⁽⁴⁾	V _{IN} = 0.4V, I _{ON} = -8mA	3.0		0.35		Ω
R _{ON} Flatness	R _{ON} Flatness ⁽³⁾	V _{IN} = 0.0V - 1.0V, I _{ON} = -8mA	3.0		2.0		Ω
I _{CC}	Quiescent Supply Current	V _{IN} = 0.0V or V _{CC} , I _{OUT} = 0	4.3			1.0	μA
I _{CCT}	Increase in I _{CC} Current per Control Voltage and V _{CC} Levels	V _{IN} = 2.6V, V _{CC} = 4.3V	4.3			10.0	μA

Notes:

- Measured by the voltage drop between Dn, HSD, and Dn pins at the indicated current through the switch. On resistance is determined by the lower of the voltage on the two ports.
- Guaranteed by characterization.

AC Electrical Characteristics

All typical values are for V_{CC} = 3.3V are at 25°C unless otherwise specified.

Symbol	Parameter	Conditions	V _{CC} (V)	T _A = -40°C to +85°C			Unit	Figure Number
				Min.	Typ.	Max.		
t _{ON}	Turn-On Time, OE to Output	V _{IN} = 0.8V, R _L = 50Ω, C _L = 5pF	3.0 to 3.6		15.0	30.0	ns	Figure 12
t _{OFF}	Turn-Off Time, OE to Output	V _{IN} = 0.8V, R _L = 50Ω, C _L = 5pF	3.0 to 3.6		12.0	25.0	ns	Figure 12
t _{PD}	Propagation Delay ⁽⁴⁾	R _L = 50Ω, C _L = 5pF	3.3		0.25		ns	Figure 10 Figure 11
t _{BBM}	Break-Before-Make	R _L = 50Ω, C _L = 5pF, V _{IN} = 0.8V	3.0 to 3.6	2.0		6.5	ns	Figure 13
O _{IRR}	Off Isolation (Non-Adjacent)	R _T = 50Ω, f = 240MHz	3.0 to 3.6		-35.0		dB	Figure 16
Xtalk	Non-Adjacent Channel Crosstalk	R _T = 50Ω, f = 240MHz	3.0 to 3.6		-55.0		dB	Figure 17
BW	-3dB Bandwidth	R _T = 50Ω, C _L = 0pF	3.0 to 3.6		720		MHz	Figure 15
		R _T = 50Ω, C _L = 5pF			550			

USB Hi-Speed Related AC Electrical Characteristics

Symbol	Parameter	Conditions	V _{CC} (V)	T _A = -40°C to +85°C			Unit	Figure Number
				Min.	Typ.	Max.		
t _{SK(O)}	Channel-to-Channel Skew ⁽⁵⁾	C _L = 5pF	3.0 to 3.6		50.0		ps	Figure 10 Figure 14
t _{SK(P)}	Skew of Opposite Transitions of the Same Output ⁽⁵⁾	C _L = 5pF	3.0 to 3.6		20.0		ps	Figure 10 Figure 14
t _J	Total Jitter ⁽⁵⁾	R _L = 50Ω, C _L = 5pF, t _R = t _F = 500ps at 480 Mbps (PRBS = 2 ¹⁵ - 1)	3.0 to 3.6		200		ps	

Note:

5. Guaranteed by design.

Capacitance

Symbol	Parameter	Conditions	T _A = -40°C to +85°C			Unit	Figure Number
			Min.	Typ.	Max.		
C _{IN}	Control Pin Input Capacitance	V _{CC} = 0V		1.0		pF	Figure 19
C _{ON}	D1 _n , D2 _n , Dn On Capacitance	V _{CC} = 3.3, \overline{OE} = 0V		3.7		pF	Figure 18
C _{OFF}	D1 _n , D2 _n Off Capacitance	V _{CC} and \overline{OE} = 3.3		1.7		pF	Figure 19

Typical Characteristics

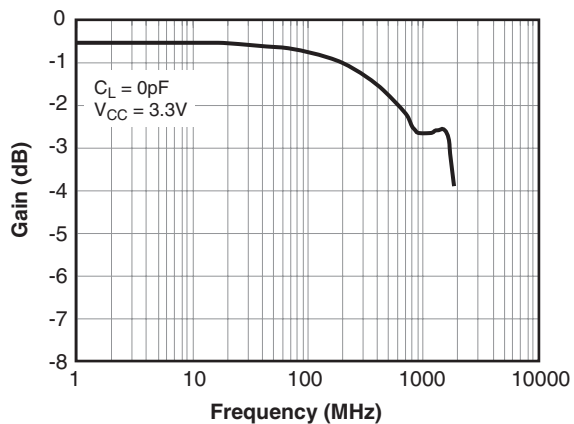

Figure 5. Gain vs. Frequency

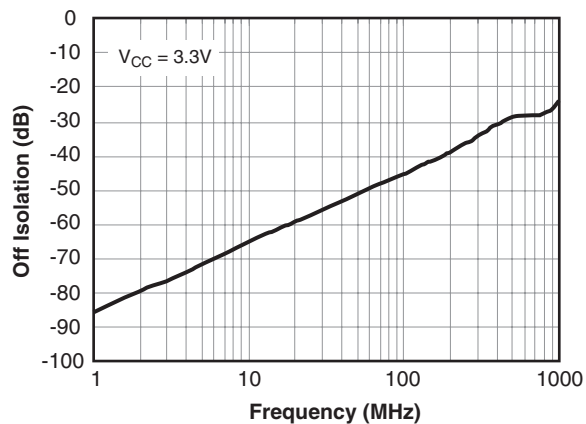

Figure 6. Off Isolation

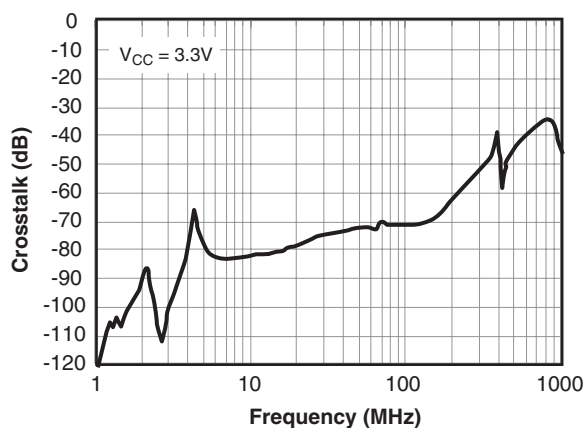

Figure 7. Crosstalk

Test Diagrams

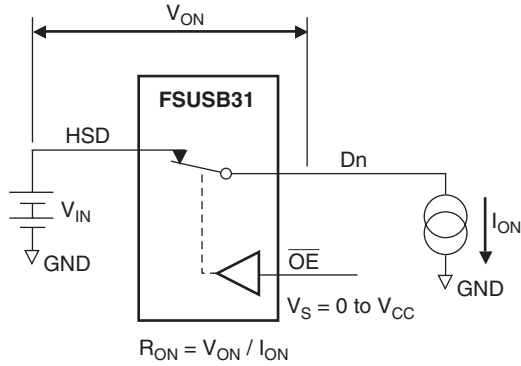

Figure 8. On Resistance

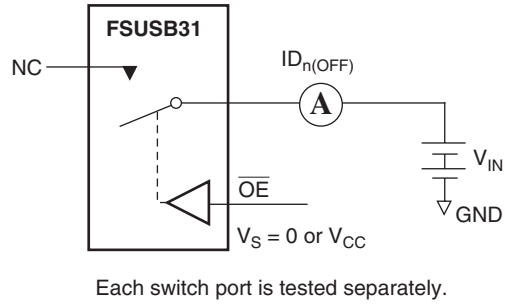
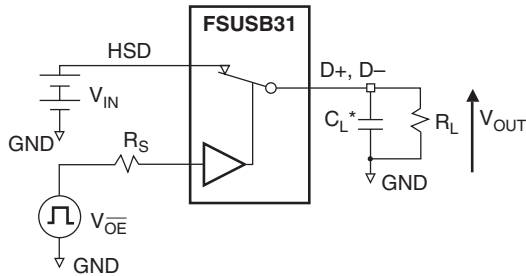

Figure 9. Off Leakage



R_L , R_S , and C_L are functions of the application environment (see AC Electrical tables for specific values).

* C_L includes test fixture and stray capacitance.

Figure 10. AC Test Circuit Load

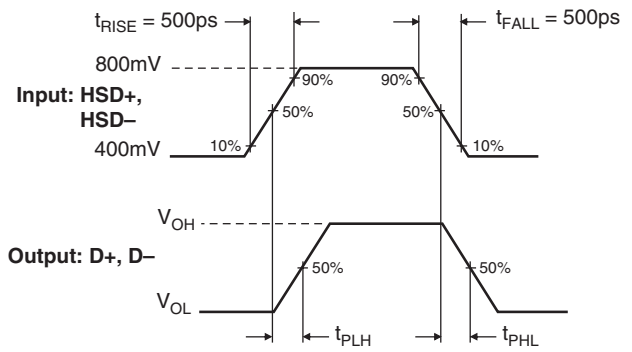

Figure 11. Switch Propagation Delay Waveforms (t_{PD})

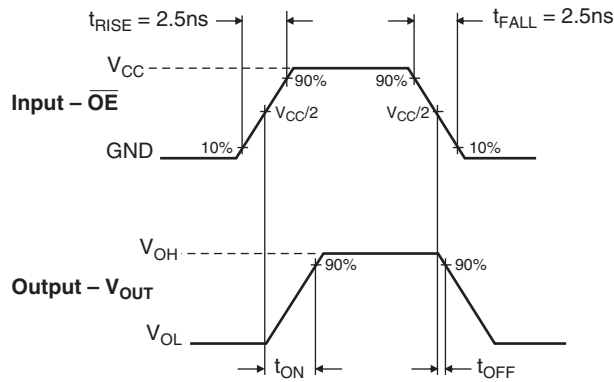

Figure 12. Turn On / Turn Off Waveform (t_{ON} / t_{OFF})

Test Diagrams (Continued)

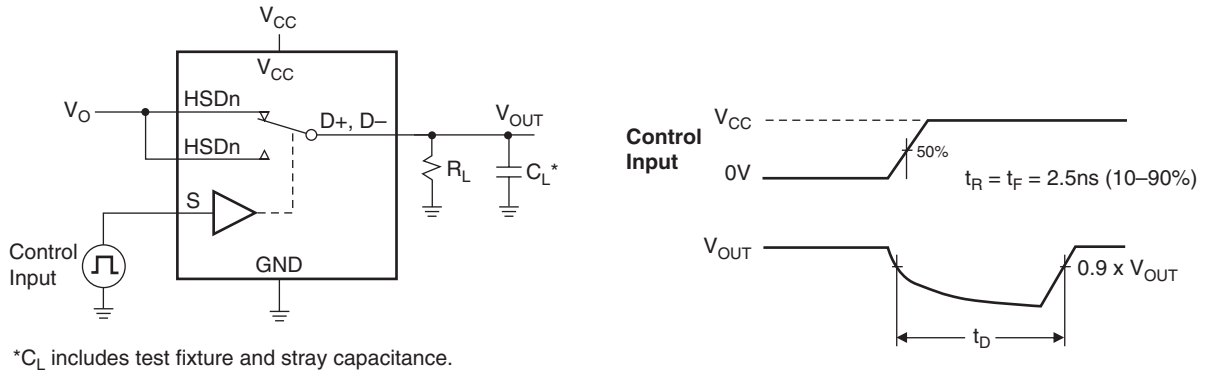

Figure 13. Break-Before-Make (t_{BBM})

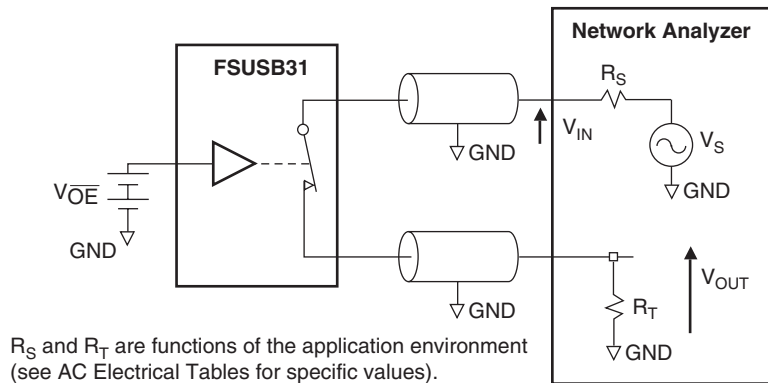
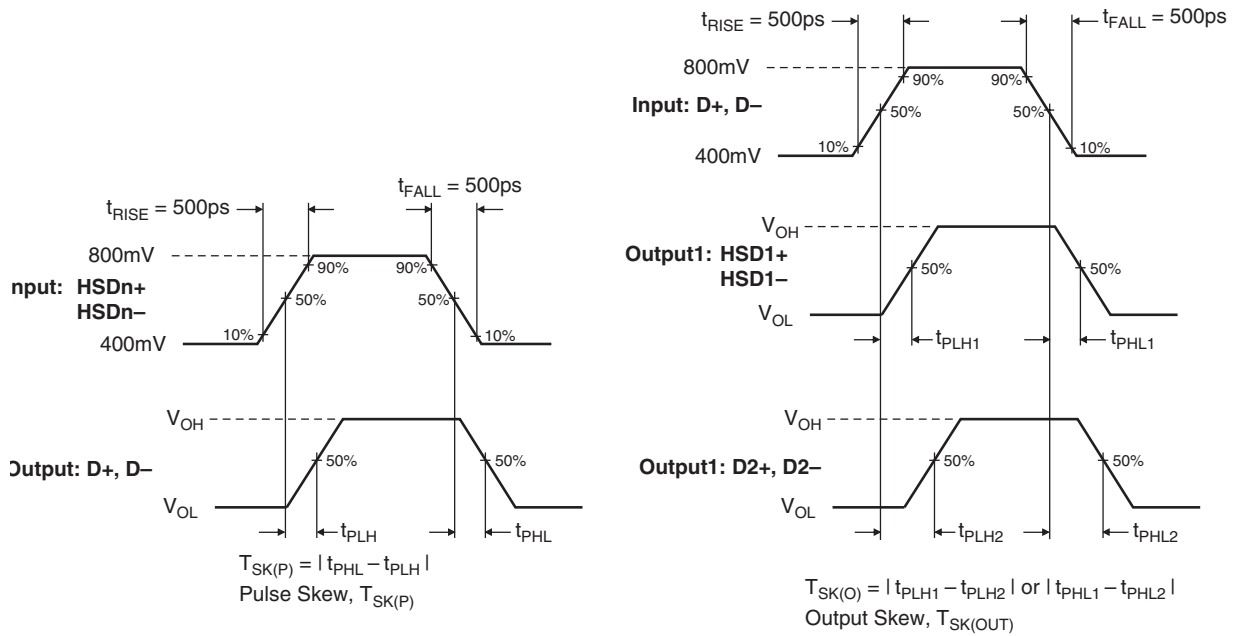

Figure 15. Bandwidth

Test Diagrams (Continued)

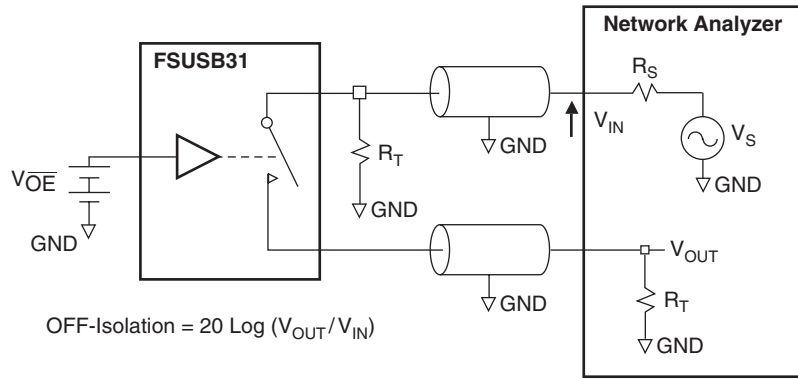

Figure 16. Channel Off Isolation

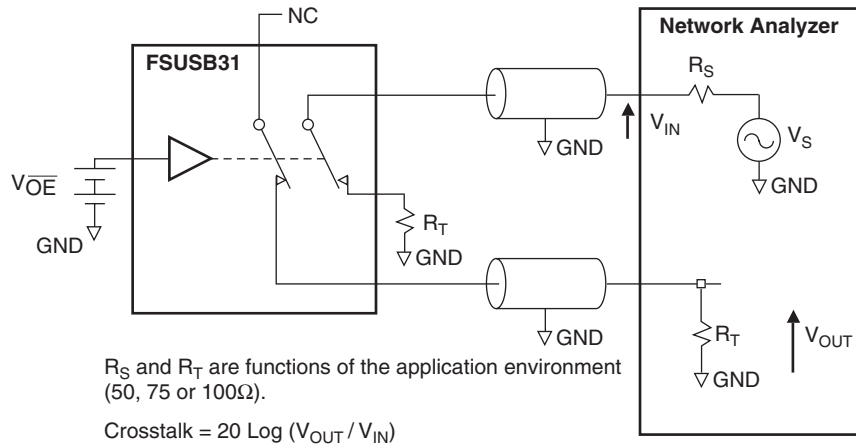

Figure 17. Non-Adjacent Channel-to-Channel Crosstalk

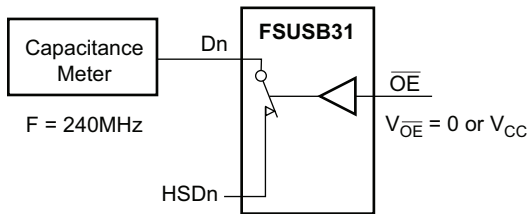

Figure 18. Channel On Capacitance

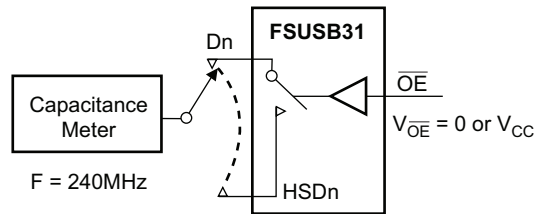

Figure 19. Channel Off Capacitance

Application Guidance: Meeting USB 2.0 Vbus Short Requirements

In section 7.1.1 of the USB 2.0 specification, it notes that USB devices must be able to withstand a Vbus short to D+ or D- when the USB device is either powered off or powered on. The FSUSB31 can be successfully configured to meet both these requirements.

Power-Off Protection

For a Vbus short circuit, the switch is expected to withstand such a condition for at least 24 hours. The FSUSB31 has specially designed circuitry which prevents unintended signal bleed through as well as guaranteed system reliability during a power-down, over-voltage condition. The protection has been added to the common pins (D+, D-).

Power-On Protection

The USB 2.0 specification also notes that the USB device should be capable of withstanding a Vbus short during transmission of data. Fairchild recommends adding a 100Ω series resistor between the switch VCC pin and supply rail to protect against this case. This modification works by limiting current flow back into the VCC rail during the over-voltage event so current remains within the safe operating range. In this application, the switch passes the full 5.25V input signal through to the selected output, while maintaining specified off isolation on the un-selected pins.

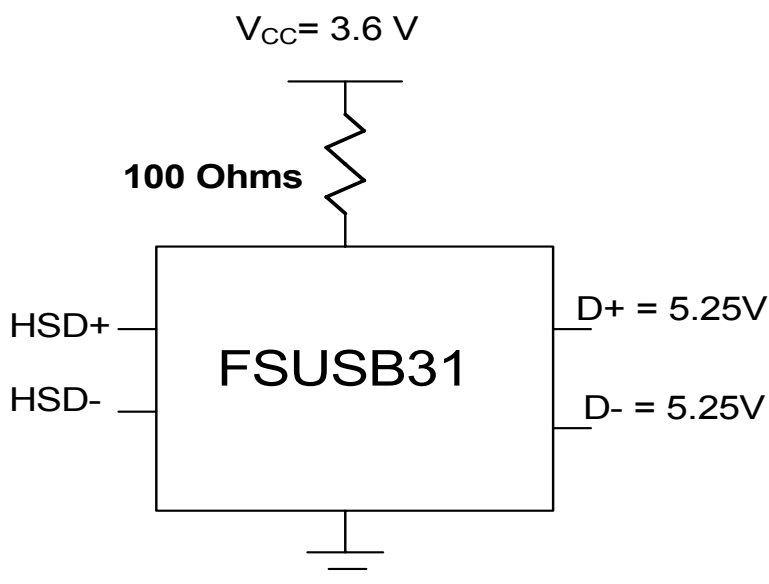

Figure 20. A 100Ω resistor in series with the V_{CC} supply allows the FSUSB31 to withstand a Vbus short when powered up

For more information, see Applications Note *AN-6022 Using the FSUSB30/FSUSB31 to Comply with USB 2.0 Fault Condition Requirements* at www.fairchildsemi.com

Tape and Reel Specification

Tape Format for MircoPak

Package Designator	Tape Section	Number Cavities	Cavity Status	Cover Tape Status
L8X	Leader (Start End)	125 (typ)	Empty	Sealed
	Carrier	5000	Filled	Sealed
	Trailer (Hub End)	75 (typ)	Empty	Sealed

Tape Dimension

Dimensions are in millimeters unless otherwise specified.

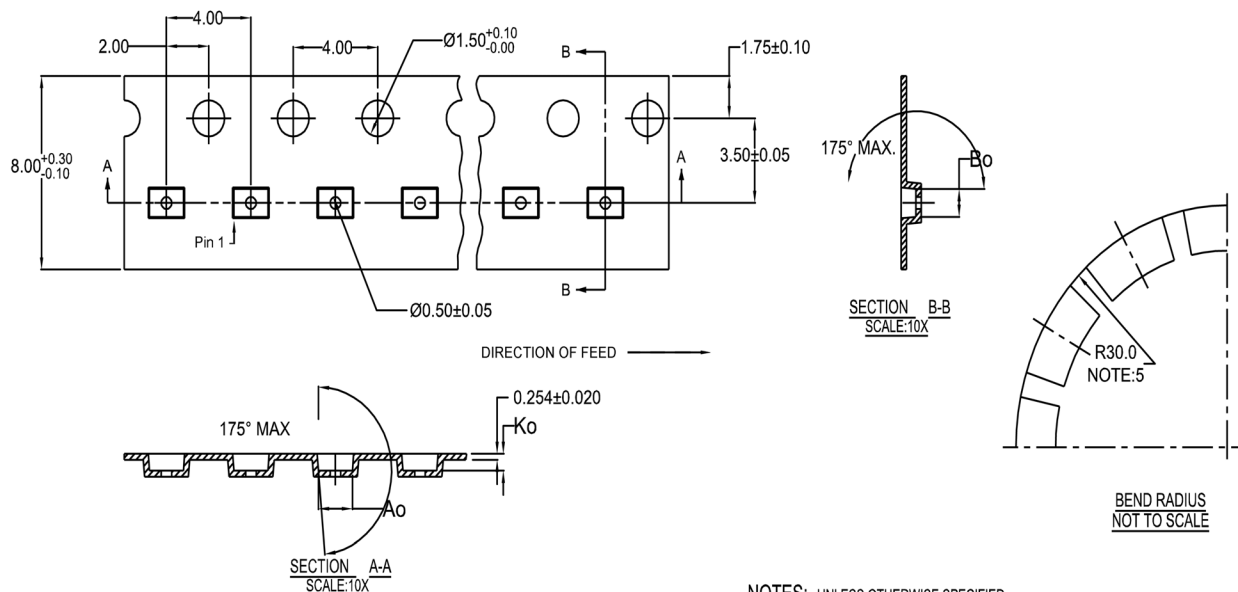

10	300056	2.30 ± 0.05	1.78 ± 0.05	0.68 ± 0.05
8	300038	1.78 ± 0.05	1.78 ± 0.05	0.68 ± 0.05
6	300033	1.60 ± 0.05	1.15 ± 0.05	0.70 ± 0.05

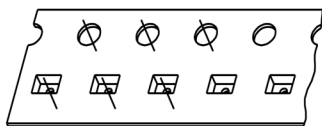

NOTES: UNLESS OTHERWISE SPECIFIED

1. ACCUMULATED 50 SPROCKETS, SPROCKET HOLE PITCH IS 200.00 ± 0.30 MM
2. NO INDICATED CORNER RADIUS IS 0.127MM
3. CAMBER NOT TO EXCEED 1MM IN 100MM
4. SMALLEST ALLOWABLE BENDING RADIUS
5. POCKET POSITION RELATIVE TO SPROCKET HOLE MEASURED AS TRUE POSITION OF POCKET, NOT POCKET HOLE

Reel Dimension for MircoPak

Dimensions are in inches (millimeters) unless otherwise specified.

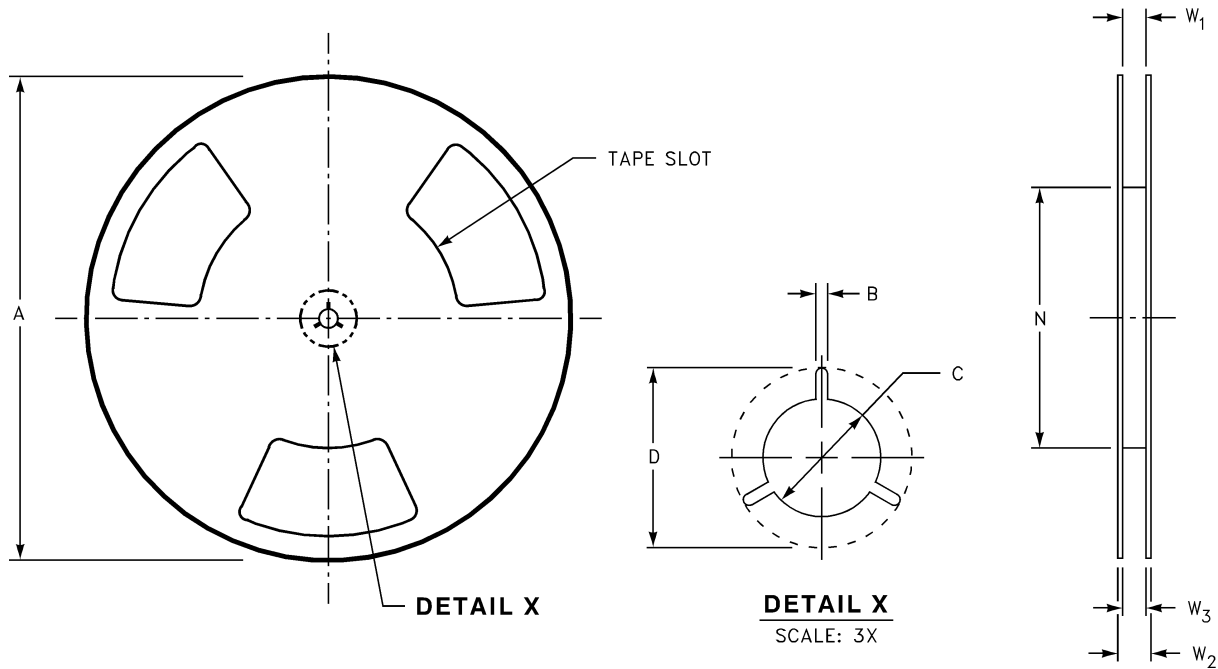

Tape Size	A	B	C	D	N	W1	W2	W3
(8mm)	7.0 (177.8)	0.059 (1.50)	0.512 (13.00)	0.795 (20.20)	2.165 (55.00)	0.331 + 0.059/-0.000 (8.40 + 1.50/-0.00)	0.567 (14.40)	W1 + 0.078/-0.039 (W1 + 2.00/-1.00)

Physical Dimensions

Dimensions are in millimeters unless otherwise noted.

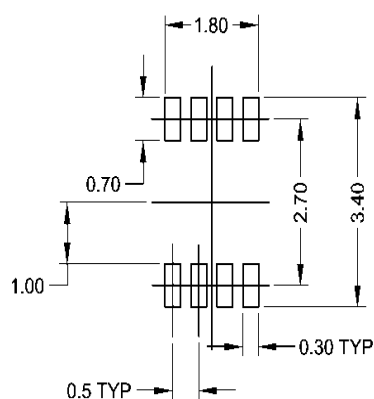
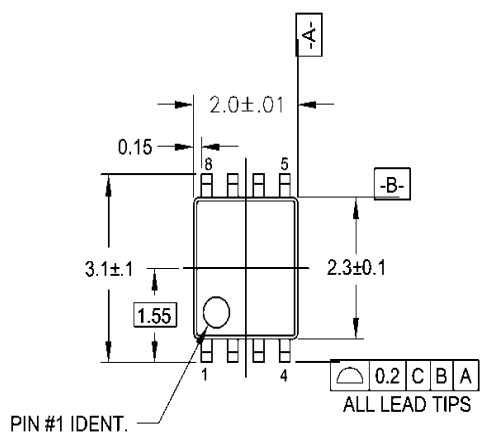

LAND PATTERN RECOMMENDATION

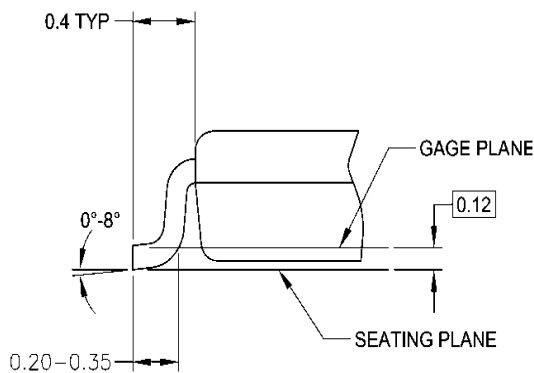
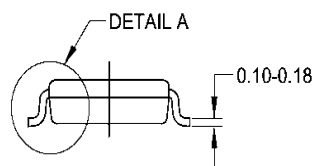
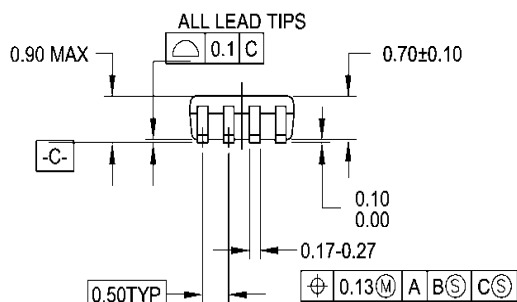

DETAIL A

NOTES:

- A. CONFORMS TO JEDEC REGISTRATION MO-187
- B. DIMENSIONS ARE IN MILLIMETERS.
- C. DIMENSIONS ARE EXCLUSIVE OF BURRS, MOLD FLASH, AND TIE BAR EXTRUSIONS.
- D. DIMENSIONS AND TOLERANCES PER ANSI Y14.5M, 1982.

MAB08AREVC

Figure 21. Pb-Free, 8-Lead US8, JEDEC MO-187, Variation CA 3.1mm Wide

Physical Dimensions (Continued)

Dimensions are in millimeters unless otherwise noted.

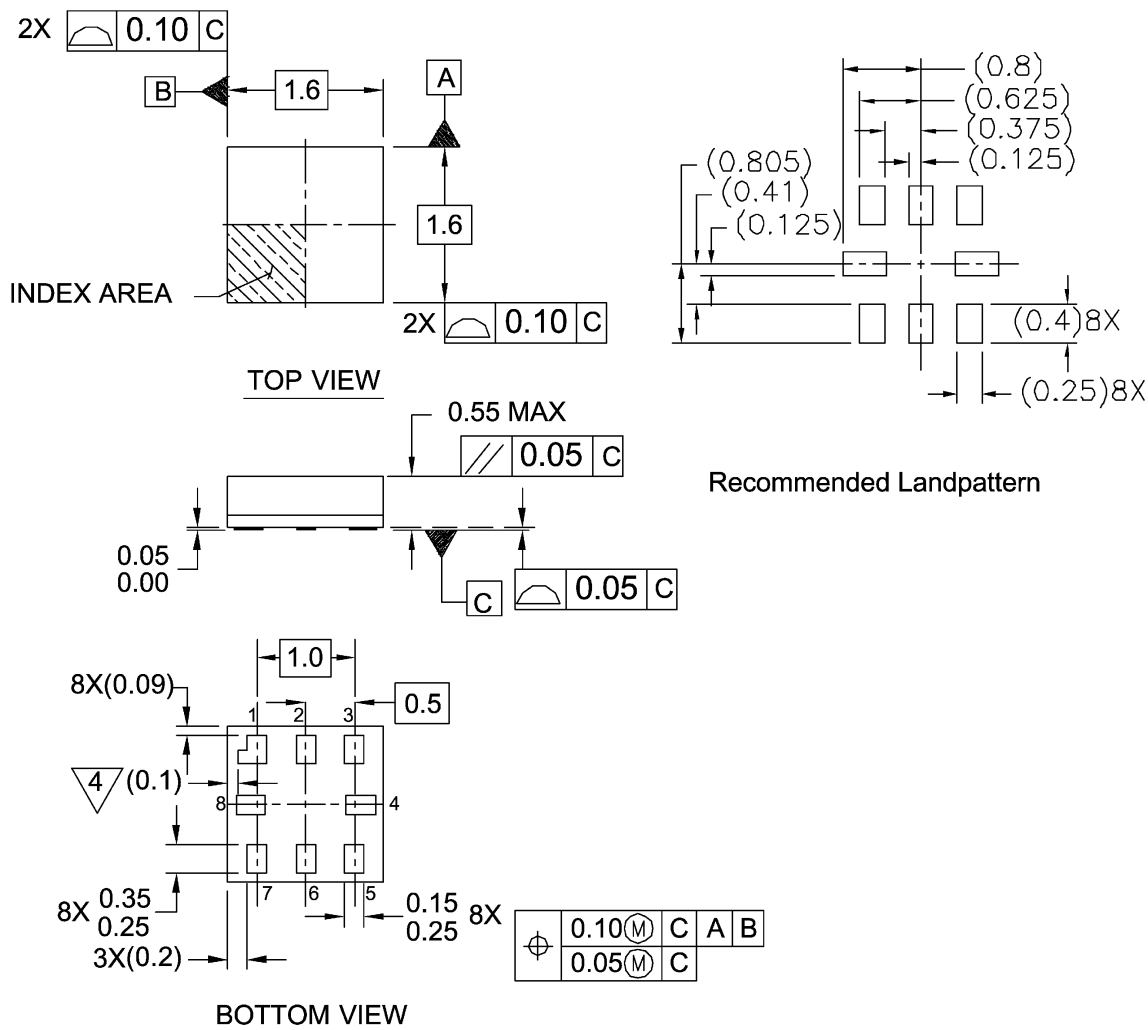

Notes:

1. PACKAGE CONFORMS TO JEDEC MO-255 VARIATION UAAD
2. DIMENSIONS ARE IN MILLIMETERS
3. DRAWING CONFORMS TO ASME Y.14M-1994

4/PIN 1 FLAG, END OF PACKAGE OFFSET.

MAC08AREVC

Figure 22. Pb-Free, 8-Lead MicroPak, 1.6mm Wide

TRADEMARKS

The following are registered and unregistered trademarks Fairchild Semiconductor owns or is authorized to use and is not intended to be an exhaustive list of all such trademarks.

ACE ^x ™	FACT Quiet Series™	OCX™	SILENT SWITCHER®	UniFET™
ActiveArray™	GlobalOptoisolator™	OCXPro™	SMART START™	VCX™
Bottomless™	GTO™	OPTOLOGIC®	SPM™	Wire™
Build it Now™	HiSeC™	OPTOPLANAR™	Stealth™	
CoolFET™	I ² C™	PACMAN™	SuperFET™	
CROSSVOLT™	i-Lo™	POP™	SuperSOT™_3	
DOME™	ImpliedDisconnect™	Power247™	SuperSOT™_6	
EcoSPARK™	IntelliMAX™	PowerEdge™	SuperSOT™_8	
E ² C MOS™	ISOPLANAR™	PowerSaver™	SyncFET™	
EnSigna™	LittleFET™	PowerTrench®	TCM™	
FACT®	MICROCOUPLER™	QFET®	TinyBoost™	
FAST®	MicroFET™	QS™	TinyBuck™	
FAST _r ™	MicroPak™	QT Optoelectronics™	TinyPWM™	
FPS™	MICROWIRE™	Quiet Series™	TinyPower™	
FRFET™	MSX™	RapidConfigure™	TinyLogic®	
	MSXPro™	RapidConnect™	TINYOPTO™	
Across the board. Around the world.™		μSerDes™	TruTranslation™	
The Power Franchise®		ScalarPump™	UHC®	
Programmable Active Droop™				

DISCLAIMER

FAIRCHILD SEMICONDUCTOR RESERVES THE RIGHT TO MAKE CHANGES WITHOUT FURTHER NOTICE TO ANY PRODUCTS HEREIN TO IMPROVE RELIABILITY, FUNCTION, OR DESIGN. FAIRCHILD DOES NOT ASSUME ANY LIABILITY ARISING OUT OF THE APPLICATION OR USE OF ANY PRODUCT OR CIRCUIT DESCRIBED HEREIN; NEITHER DOES IT CONVEY ANY LICENSE UNDER ITS PATENT RIGHTS, NOR THE RIGHTS OF OTHERS. THESE SPECIFICATIONS DO NOT EXPAND THE TERMS OF FAIRCHILD'S WORLDWIDE TERMS AND CONDITIONS, SPECIFICALLY THE WARRANTY THEREIN, WHICH COVERS THESE PRODUCTS.

LIFE SUPPORT POLICY

FAIRCHILD'S PRODUCTS ARE NOT AUTHORIZED FOR USE AS CRITICAL COMPONENTS IN LIFE SUPPORT DEVICES OR SYSTEMS WITHOUT THE EXPRESS WRITTEN APPROVAL OF FAIRCHILD SEMICONDUCTOR CORPORATION.

As used herein:

- Life support devices or systems are devices or systems which, (a) are intended for surgical implant into the body, or (b) support or sustain life, or (c) whose failure to perform when properly used in accordance with instructions for use provided in the labeling, can be reasonably expected to result in significant injury to the user.
- A critical component is any component of a life support device or system whose failure to perform can be reasonably expected to cause the failure of the life support device or system, or to affect its safety or effectiveness.

PRODUCT STATUS DEFINITIONS

Definition of Terms

Datasheet Identification	Product Status	Definition
Advance Information	Formative or In Design	This datasheet contains the design specifications for product development. Specifications may change in any manner without notice.
Preliminary	First Production	This datasheet contains preliminary data, and supplementary data will be published at a later date. Fairchild Semiconductor reserves the right to make changes at any time without notice to improve design.
No Identification Needed	Full Production	This datasheet contains final specifications. Fairchild Semiconductor reserves the right to make changes at any time without notice to improve design.
Obsolete	Not In Production	This datasheet contains specifications on a product that has been discontinued by Fairchild semiconductor. The datasheet is printed for reference information only.

Rev. I22