



8-Bit, Ultra-High-Speed DAC

MAX5140

General Description

The MAX5140 is a monolithic, 8-bit digital-to-analog converter (DAC) capable of accepting video data at 400MSPS. Complete with video controls (sync, blank, reference white (force high), and bright), the MAX5140 directly drives doubly terminated 50Ω or 75Ω loads to standard composite video levels. Standard setup level is 7.5IRE. The MAX5140 includes an internal precision bandgap reference that can drive two other MAX5140s in an RGB graphics system.

The MAX5140 is available in a 24-pin PDIP package in the -20°C to +85°C industrial temperature range.

Applications

- Raster Graphics
- High-Resolution Color or Monochrome Displays to 2k x 2k Pixels
- Medical Electronics: CAT, PET, and MR Imaging Displays
- CAD/CAE Workstations
- Solids Modeling
- General-Purpose, High-Speed Digital-to-Analog Conversion
- Digital Synthesizers
- Automated Test Equipment
- Digital Transmitters/Modulators

Features

- ◆ 400MSPS Nominal Conversion Rate
- ◆ RS-343-A Compatible
- ◆ Complete Video Controls: Sync, Blank, Bright, and Reference White (force high)
- ◆ ECL Compatible
- ◆ Single Power Supply
- ◆ Registered Data and Video Controls
- ◆ Differential Current Outputs
- ◆ Stable On-Chip Bandgap Reference
- ◆ 50Ω and 75Ω Output Drive
- ◆ ESD-Protected Data and Control Inputs

Ordering Information

PART	TEMP. RANGE	PIN-PACKAGE
MAX5140IPG	-20°C to +85°C	24 Plastic DIP

Pin Configuration

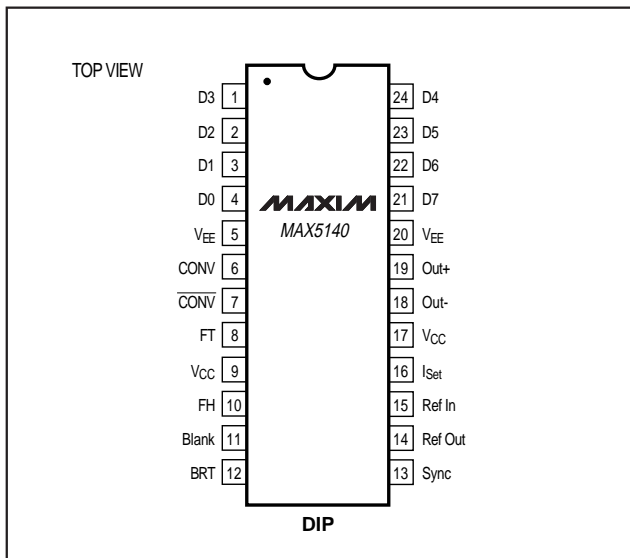

Functional Diagram

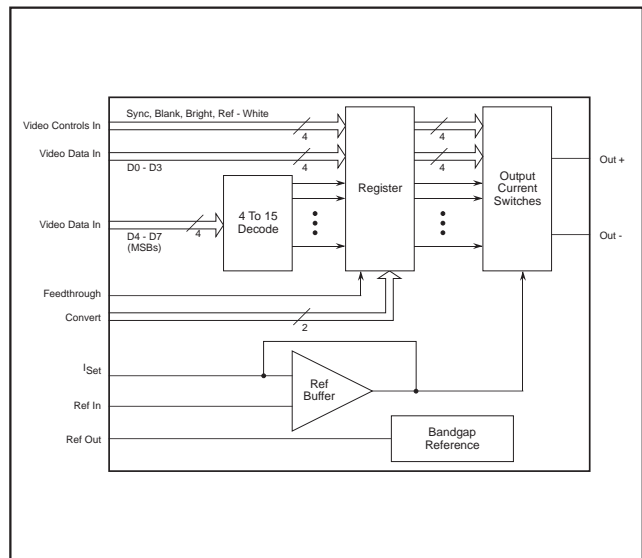

For free samples & the latest literature: <http://www.maxim-ic.com>, or phone 1-800-998-8800.
For small orders, phone 408-737-7600 ext. 3468.

8-Bit, Ultra-High-Speed DAC

ABSOLUTE MAXIMUM RATINGS

Supply Voltage	
V _{EE} (measured to V _{CC})	-7.0V to 0.5V
Input Voltages	
CONV, Data, and Controls (measured to V _{CC})	V _{EE} to 0.5V
Ref+ (measured to V _{CC})	V _{EE} to 0.5V
Ref- (measured to V _{CC})	V _{EE} to 0.5V

Operating Temperature Ranges	
Ambient	-20°C to +85°C
Junction	+175°C
Lead Temperature (soldering, 10sec)	+300°C
Storage Temperature Range	-60°C to +150°C

Stresses beyond those listed under "Absolute Maximum Ratings" may cause permanent damage to the device. These are stress ratings only, and functional operation of the device at these or any other conditions beyond those indicated in the operational sections of the specifications is not implied. Exposure to absolute maximum rating conditions for extended periods may affect device reliability.

DC ELECTRICAL CHARACTERISTICS

(V_{CC} = ground, V_{EE} = -5.2V ± 0.3V, C_C = 0pF, I_{SET} = 1.105mA, T_A = T_{MIN} to T_{MAX}, unless otherwise noted.)

PARAMETER	SYMBOL	CONDITIONS	TEST LEVEL	MIN	TYP	MAX	UNITS
Integral Linearity Error	ILE	1.0mA < I _{SET} < 1.3mA	VI	-0.37		0.37	% Full Scale
				-0.95		0.95	LSB
Differential Linearity Error	DLE	1.0mA < I _{SET} < 1.3mA	VI	-0.2		0.2	% Full Scale
				-0.5		0.5	LSB
Gain Error			VI	-6.5		6.5	% Full Scale
Gain-Error Tempco			V		150		ppm/°C
Bandgap Tempco			V		100		ppm/°C
Input Capacitance, I _{SET} , Ref Out	C _{REF}		V		5		pF
Compliance Voltage, Positive Output			VI	-1.2		1.5	V
Compliance Voltage, Negative Output			VI	-1.2		1.5	V
Equivalent Output Resistance	R _{OUT}		VI	20			kΩ
Output Capacitance	C _{OUT}		V		9		pF
Maximum Current, Positive Output	I _{O+(MAX)}		IV	45			mA
Maximum Current, Negative Output	I _{O-(MAX)}		IV	-45			mA
Output Offset Current	I _{OS}		VI		0.05	0.5	LSB
Input Voltage, Logic High	V _{IH}		VI	-1.0			V
Input Voltage, Logic Low	V _{IL}		VI			-1.5	V
Convert Voltage, Common-Mode Range			IV	-0.5		-2.5	V
Convert Voltage, Differential			IV	0.4		1.2	V
Input Current, Logic Low, Data and Controls	I _{IL}		VI		35	120	μA
Input Current, Logic High, Data and Controls	I _{IH}		VI		40	120	μA
Input Current, Convert	I _{CONV}		VI		2	60	μA

8-Bit, Ultra-High-Speed DAC

MAX5140

DC ELECTRICAL CHARACTERISTICS (continued)

(V_{CC} = ground, V_{EE} = -5.2V ±0.3V, C_C = 0pF, I_{SET} = 1.105mA, T_A = T_{MIN} to T_{MAX}, unless otherwise noted.)

PARAMETER	SYMBOL	CONDITIONS	TEST LEVEL	MIN	TYP	MAX	UNITS
Reference Voltage (measured to V _{CC})	V _{REF}		VI	-1.3	-1.2	-1.0	V
Reference Output Current	I _{REF}		VI	-50			μA
Input Capacitance, Data and Controls	C _{IN}		V		3		pF
Power-Supply Sensitivity			VI	-120	20	120	μA/V
Supply Current	I _{EE}		VI		155	220	mA

AC ELECTRICAL CHARACTERISTICS

(R_L = 37.5Ω, C_L = 5pF, I_{SET} = 1.105mA, T_A = +25°C, unless otherwise noted.)

PARAMETER	SYMBOL	CONDITIONS	TEST LEVEL	MIN	TYP	MAX	UNITS
Maximum Conversion Rate			IV	385	400		Msp/s
Rise Time	t _R	10% to 90% G.S. R _L = 25Ω	IV			900 600	ps
Current-Settling Time, Clocked Mode	t _{SI}	To 0.2% G.S. R _L = 25Ω	V		4 3		ns
Clock to Output Delay, Clocked Mode	t _{DSC}	T _A = T _{MIN} to T _{MAX}	III IV		2.2	4 4.5	ns
Data to Output Delay, Transparent Mode	t _{DST}	T _A = T _{MIN} to T _{MAX}	III IV		3.2	6 6	ns
Glitch Energy		Area = 1/2VT	V		4		pV-s
Convert Pulse Width	t _{PWH} , t _{PWL}		III	1.3			ns
Reference Bandwidth	-3dB		V		1.25		MHz
Setup Time, Data and Controls	t _S		III	1.0			ns
Hold Time, Data and Controls	t _H		III	0.5			ns
Slew Rate		20% to 80% G.S.	V		700		V/μs
Clock Feedthrough			III			-48	dB

TEST-LEVEL CODES

All electrical characteristics are subject to the following conditions:

All parameters having min/max specifications are guaranteed. The Test Level column indicates the specific device testing actually performed during production and Quality Assurance inspection. Any blank section in the data column indicates that the specification is not tested at the specified condition.

Unless otherwise noted, all tests are pulsed tests; therefore, T_j = T_C = T_A.

TEST LEVEL

I
II
III
IV
V
VI

TEST PROCEDURE

100% production tested at the specified temperature.
100% production tested at T_A = +25°C, and sample-tested at the specified temperatures.
QA sample tested at only the specified temperatures.
Parameter is guaranteed (but not tested) by design and characterization data.
Parameter is a typical value for reference.
100% production tested at T_A = +25°C. Parameter is guaranteed over specified temperature range.

8-Bit, Ultra-High-Speed DAC

Pin Description

PIN	NAME	FUNCTION
1, 2, 3	D3, D2, D1	Data Bits 3, 2, and 1
4	D0	Data Bit 0 (LSB)
5, 20	V _{EE}	Negative Supply
6	CONV	Convert Clock Input
7	$\overline{\text{CONV}}$	Convert-Clock-Input Complement
8	FT	Register Feedthrough Control
9, 17	V _{CC}	Positive Supply
10	FH	Data Force-High Control
11	Blank	Video Blank Input
12	BRT	Video Bright Input
13	Sync	Video Sync Input
14	Ref Out	Reference Output
15	Ref In	Reference Input
16	I _{Set}	Reference Current
18	Out-	Output Current Negative
19	Out+	Output Current Positive
21	D7	Data Bit 7 (MSB)
22, 23, 24	D6, D5, D4	Data Bits 6, 5, and 4

Detailed Description

The MAX5140 is an ultra-high-speed video digital-to-analog converter (DAC) capable of up to 400Msps conversion rates. This high speed makes the device suitable for driving 2048 x 2048 pixel displays at 60Hz to 90Hz update rates.

In addition, the MAX5140 includes an internal bandgap reference, which may be used to drive two other MAX5140s, if desired.

The MAX5140 has ECL logic-level-compatible video control and data inputs. The complementary analog output currents produced by the devices are proportional to the product of the digital control and data inputs in conjunction with the analog reference current. The MAX5140 is segmented so that the input data's four MSBs are separated into a parallel thermometer code. From here, fifteen identical current sinks are driven to fabricate sixteen coarse output levels. The remaining four LSBs drive four binary-weighted current switches.

MSB currents are then summed with the LSBs that contribute one-sixteenth of full-scale to provide the 256 distinct analog output levels.

The video-control inputs drive weighted current sinks, which are added to the output current to produce composite video-output levels. These controls (sync, blank, reference white (force high), and bright) are required in video applications.

A feature that similar video DACs do not have is feedthrough control. The feedthrough pin (FT) allows registered or unregistered operation of the video control and data inputs. In registered mode, the composite functions are latched to the pixel data to prevent screen-edge distortions (generally found on unregistered video DACs).

8-Bit, Ultra-High-Speed DAC

MAX5140

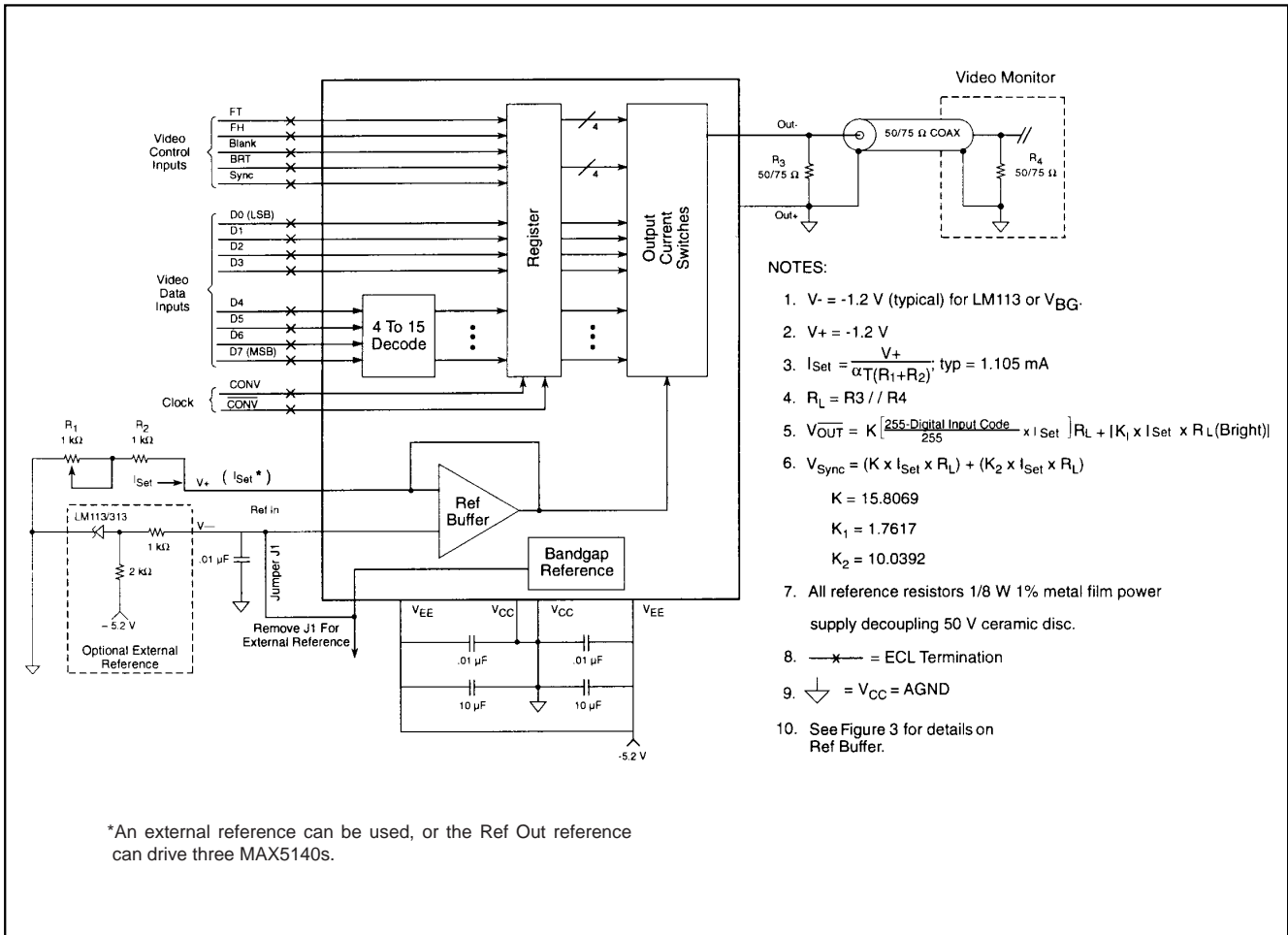

- NOTES:
- $V_- = -1.2 \text{ V}$ (typical) for LM113 or V_{BG} .
 - $V_+ = -1.2 \text{ V}$
 - $I_{Set} = \frac{V_+}{\alpha_T(R_1 + R_2)}$; typ = 1.105 mA
 - $R_L = R_3 // R_4$
 - $V_{OUT} = K \left[\frac{255 - \text{Digital Input Code}}{255} \times I_{Set} \right] R_L + |K_1 \times I_{Set} \times R_L (\text{Bright})|$
 - $V_{Sync} = (K \times I_{Set} \times R_L) + (K_2 \times I_{Set} \times R_L)$
 $K = 15.8069$
 $K_1 = 1.7617$
 $K_2 = 10.0392$
 - All reference resistors 1/8 W 1% metal film power supply decoupling 50 V ceramic disc.
 - \times = ECL Termination
 - ∇ = $V_{CC} = \text{AGND}$
 - See Figure 3 for details on Ref Buffer.

Figure 1. Typical Interface Circuit

Applications Information

General

Figure 1 shows a typical interface circuit using the MAX5140 in a color-raster application. The MAX5140 requires few external components and is extremely easy to use. The MAX5140's ultra-high operating speeds require good circuit layout, supply decoupling, and proper transmission-line design. For best performance, note the following considerations.

Input Considerations

Video-input data and controls can be directly connected to the MAX5140. Note that all ECL inputs are terminated as closely to the device as possible to

reduce ringing, crosstalk, and reflections. Maxim recommends that stripline or microstrip techniques be used for all ECL interfaces. A convenient and commonly used microstrip impedance is about 130Ω, which is easily terminated using a 330Ω resistor to V_{EE} and a 220Ω resistor to ground. This arrangement gives a Thevenin-equivalent termination of 130Ω to -2V without the need for a -2V supply. Standard single in-line package (SIP) 220/330 resistor networks are available for this purpose.

Figure 2 shows equivalent input circuits.

8-Bit, Ultra-High-Speed DAC

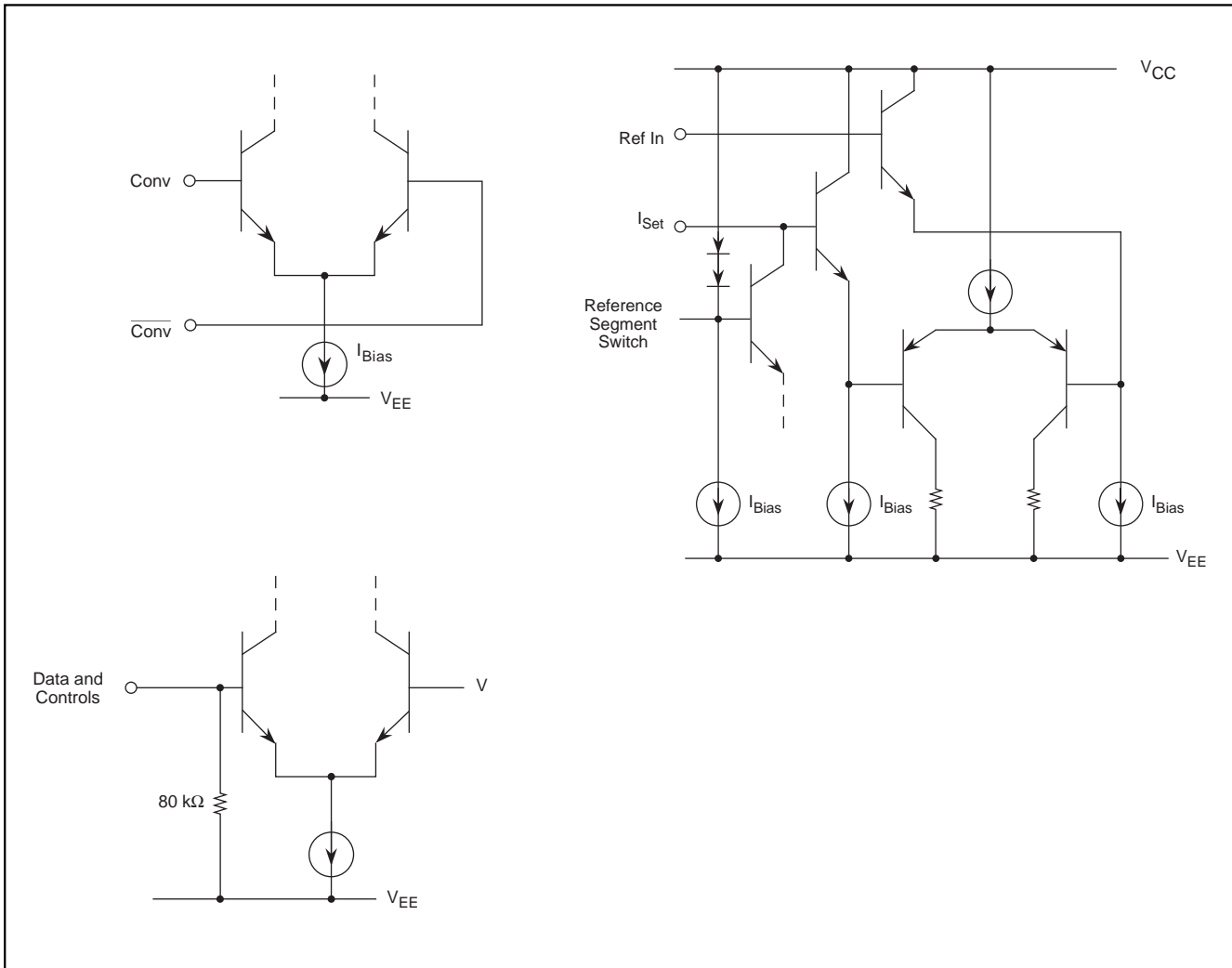

Figure 2. Equivalent Input Circuits—Data, Clock, Controls, and Reference

Output Considerations

The analog outputs are designed to directly drive a doubly terminated 50Ω or 75Ω load-transmission system as shown. The MAX5140 output source impedances are high-impedance current sinks. The load impedance (R_L) must be 25Ω or 37.5Ω to attain standard RS-343-A video levels. Any deviation from this impedance affects the resulting video output levels proportionally. As with the data interface, it is important that all analog transmission lines have matched impedance throughout, including connectors and transitions between printed wiring and coaxial cable. The combination of matched source-termination resistor R_S and

load terminator R_L minimizes reflections of both forward and reverse traveling waves in the analog transmission system.

Power Considerations

The MAX5140 has two analog power-supply pins and operates from a standard $-5.2V$ single supply. Proper supply bypassing augments the MAX5140's inherent supply-noise-rejection characteristics. As shown in Figure 1, each supply pin should be bypassed as close to the device as possible with $0.01\mu F$ and $10\mu F$ capacitors.

8-Bit, Ultra-High-Speed DAC

This device also has two analog ground pins (V_{CC}). Tie both ground pins to the analog ground plane. All power and ground pins must be connected in any application. If a +5V power source is required, the V_{CC} ground pins become the positive supply pins, while the V_{EE} supply pins become the ground pins. The relative polarities of the other input and output voltages must be maintained.

Reference Considerations

The MAX5140 has two reference inputs (Ref In and I_{Set}) and one reference output (Ref Out). The input pins are connected to the inverting and noninverting inputs of an internal amplifier that serves as a reference buffer.

The buffer amplifier's output is the reference for the current sinks. The amplifier feedback loop is connected around one of the current sinks to achieve better accuracy. (See Figure 3.)

Since the analog output currents are proportional to the digital input data and I_{Set} , full-scale output can be adjusted by varying the reference current. I_{Set} is controlled through the MAX5140's I_{Set} input. Figure 1 shows the method and the necessary equations for setting I_{Set} . The MAX5140 can use an external negative-voltage reference. The external reference must be stable to achieve a satisfactory output, and Ref In should be driven through a resistor to minimize offsets caused by bias current. To change the full-scale output, vary the value for I_{Set} with the 500 Ω to 1k Ω trimmer. A double 50 Ω load (25 Ω) can be driven if I_{Set} is

increased by 50% for doubly terminated 75 Ω video applications.

Data Inputs and Video Controls

The MAX5140 has standard, single-ended data inputs. The inputs are registered to produce the lowest differential data-propagation delay (skew) to minimize glitching. Also, four video-control inputs generate composite video outputs: sync, blank, bright, and reference white (force high). Feedthrough control is also provided. All of the controls and data inputs are ECL compatible. In addition, all have internal pulldown resistors to leave them at a logic low so the pins are inactive when not used. This is useful if the devices are applied as standard DACs without the need for video controls, or if fewer than eight bits are used.

The MAX5140 is usually configured in synchronous mode. In this mode, the controls and data are synchronized to prevent pixel dropout. This reduces screen-edge distortions and provides the lowest output noise while maintaining the highest conversion rate. With the FT control open (low), each rising edge of the convert clock (CONV) latches decoded data and control values into a D-type internal register. The switched-current sinks convert the registered data into the appropriate analog output. When FT is tied high, the control inputs and data are not registered. The analog output asynchronously tracks the input data and video controls. Feedthrough itself is asynchronous and is usually used as a DC control.

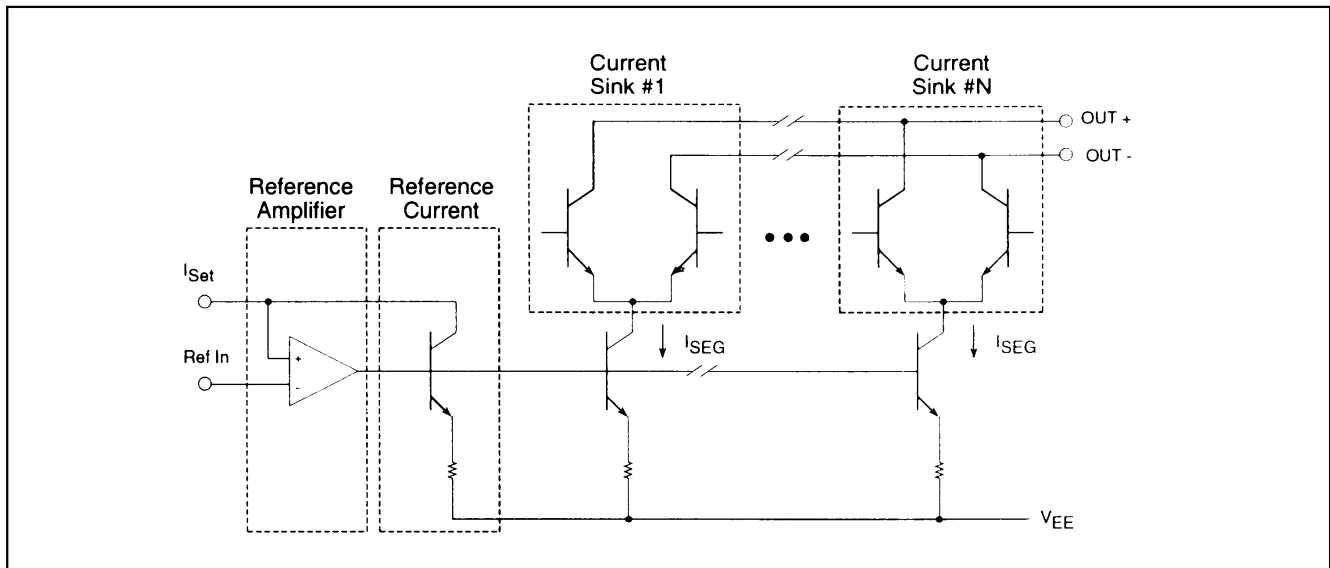

Figure 3. Reference Buffer and DAC Output Circuit

8-Bit, Ultra-High-Speed DAC

To be registered synchronously, control and data inputs must be present at the input pins for a specific setup time (t_s) before and a specific hold time (t_H) after CONV's rising edge. Setup and hold times are not important in asynchronous mode. The minimum pulse widths high (t_{PWH}) and low (t_{PWL}), as well as settling time, become the limiting factors (Figure 4).

The video controls produce the output levels needed for horizontal blanking, frame synchronization, etc., to be compatible with video-system standards as described in RS-343-A. Table 1 shows the video-control effects on the analog output. Internal logic governs blank, sync, and force high so that they override the data inputs as needed in video applications. Sync overrides both the data and other controls to produce full negative video output (Figure 5).

Reference-white, video-level output is provided by force high, which drives the internal digital data to full-scale output (100IRE units). Bright gives an additional 10% of full-scale value to the output level. This function can be used in graphic displays for highlighting menus,

cursors, or warning messages. If the devices are used in nonvideo applications, the video controls can be left open.

Convert Clock

For best performance, the clock should be differentially ECL driven by using CONV and $\overline{\text{CONV}}$ (Figure 6). Driving the clock in this manner minimizes clock noise and power-supply/output intermodulation. The clock's rising edge synchronizes the data and control inputs to the MAX5140. Since $\overline{\text{CONV}}$ determines the actual switching threshold of CONV, the clock can be driven single-ended by connecting a bias voltage to $\overline{\text{CONV}}$. This bias voltage sets the converter clock's switching threshold.

Analog Outputs

The MAX5140 has two analog outputs that are high-impedance, complementary current sinks. The outputs vary in proportion to the input data, controls, and reference-current values so that the full-scale output can be changed by setting ISet.

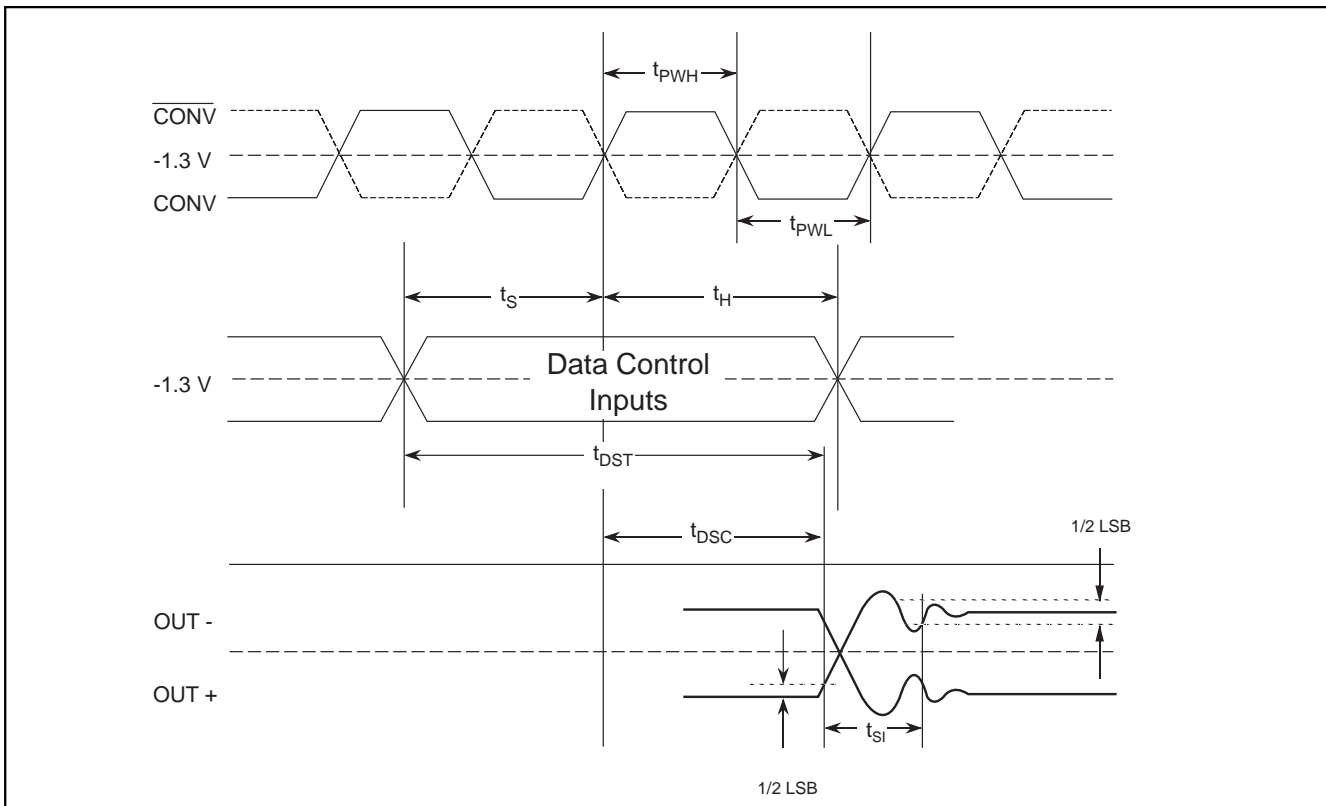

Figure 4. Timing Diagram

8-Bit, Ultra-High-Speed DAC

MAX5140

Table 1. Video-Control Operation (output values for setup: 10IRE, 75Ω standard load)

SYNC	BLANK	REF WHITE	BRIGHT	DATA INPUT	OUT- (mA)	OUT- (V)	OUT- (IRE)	DESCRIPTION
1	X	X	X	X	28.57	-1.071	-40	Sync Level
0	1	X	X	X	20.83	-0.781	0	Blank Level
0	0	1	1	X	0.00	0.000	110	Enhanced High Level
0	0	1	0	X	1.95	-0.073	100	Normal High Level
0	0	0	0	000...	19.40	-0.728	7.5	Normal Low Level
0	0	0	0	111...	1.95	-0.073	100	Normal High Level
0	0	0	1	000...	17.44	-0.654	17.5	Enhanced Low Level
0	0	0	1	111...	0.00	0.000	110	Enhanced High Level

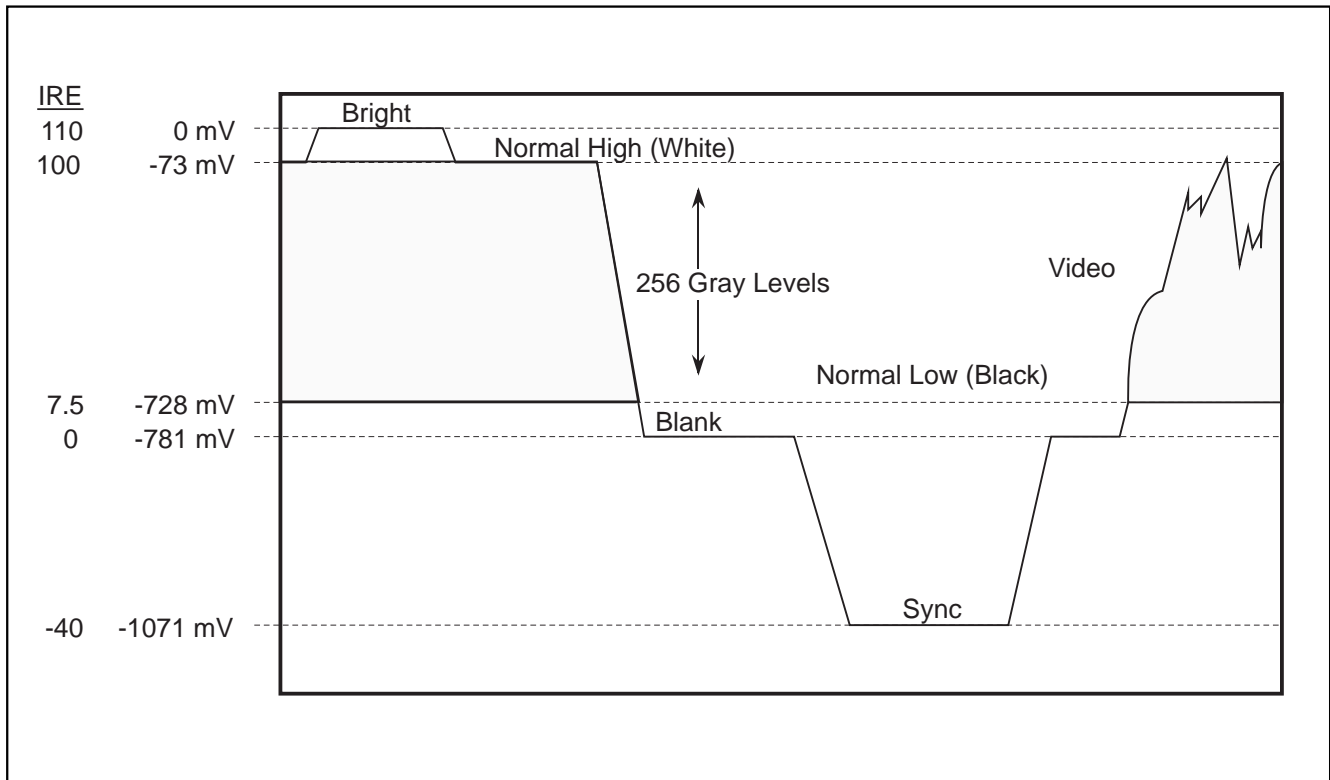

Figure 5. Video-Output Waveform for Standard Load

8-Bit, Ultra-High-Speed DAC

In video applications, the outputs can drive a doubly terminated 50Ω or 75Ω load to standard video levels. In the standard configuration shown in Figure 7, the output voltage is the product of the output current and load impedance and is between $0V$ and $-1.07V$. Out- (Figure 5) provides a video output waveform with the Sync pulse bottom at $-1.07V$. Out+ is inverted with Sync up.

Typical RGB Graphics System

In an RGB graphics system, the color displayed is determined by the combined intensities of the red, green, and blue (RGB) DAC outputs. A change in gain or offset in any of the RGB outputs affects the apparent hue displayed on the CRT screen. Thus, it is very important that the DAC's outputs track each other over a wide range of operating conditions. Since the DAC

output is proportional to the product of the reference and digital input code, use a common reference to drive all three DACs in an RGB system to minimize RGB DAC-to-DAC mismatch and improve TC tracking.

The MAX5140 contains an internal precision-bandgap reference that completely eliminates the need for an external reference. The reference can supply up to $50\mu A$ to an external load, such as two other DAC reference inputs.

The circuits shown in Figure 8 show how a single MAX5140 can be used as a master reference in a system with multiple DACs (such as RGB). The other DACs are simply slaved from the MAX5140's reference output.

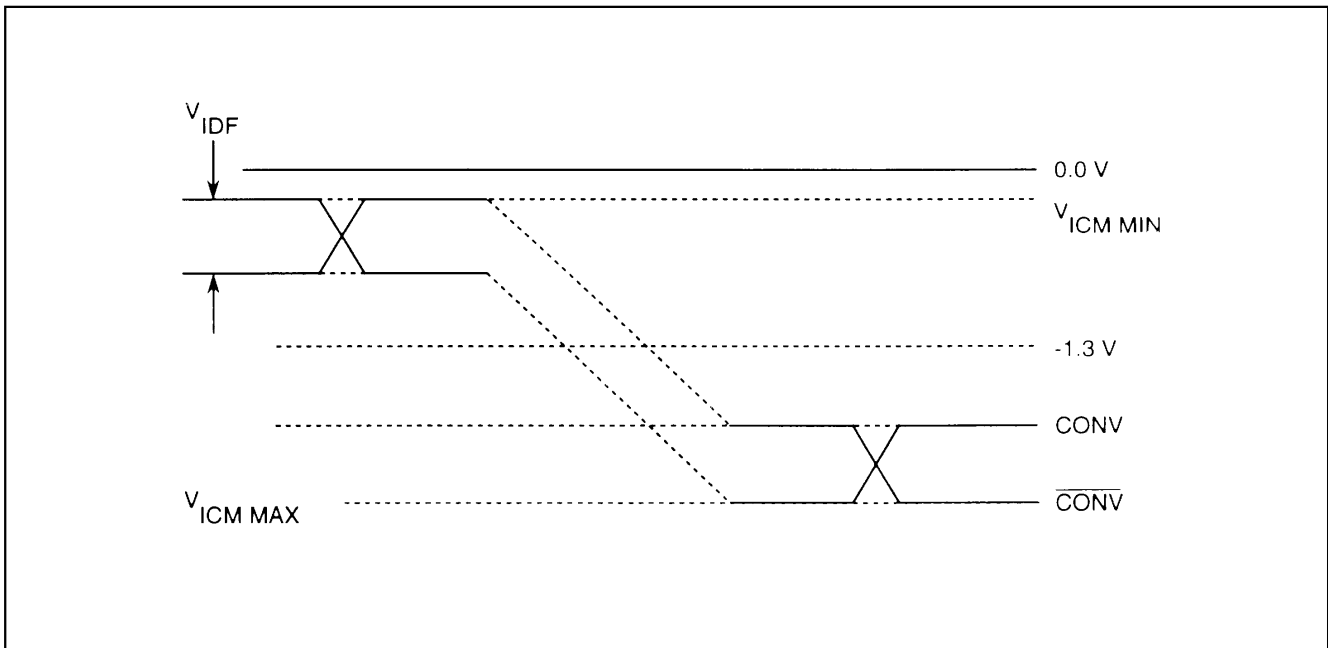

Figure 6. $CONV$, \overline{CONV} Switching Levels

8-Bit, Ultra-High-Speed DAC

MAX5140

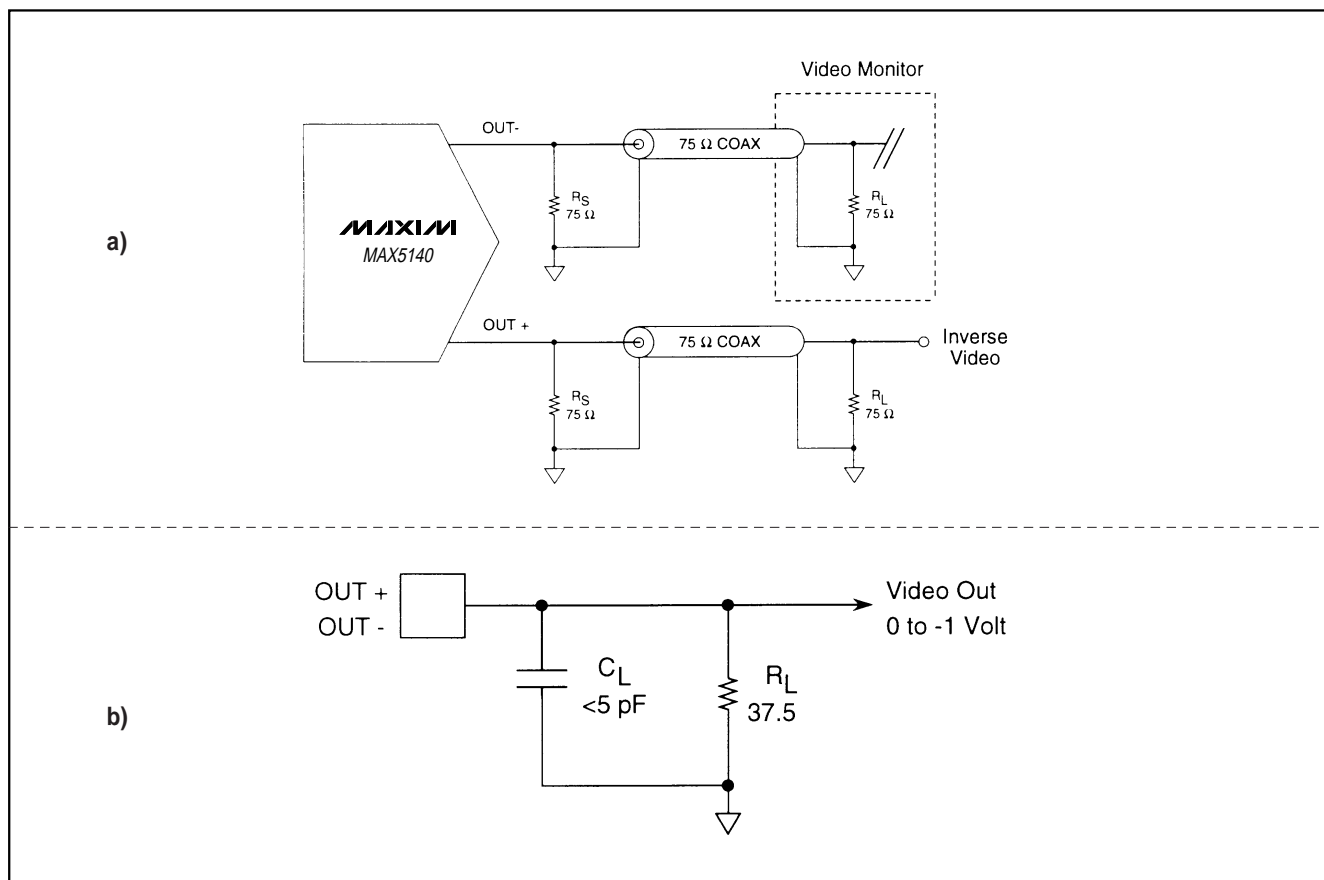

Figure 7. Standard Load (a) and Test Load (b)

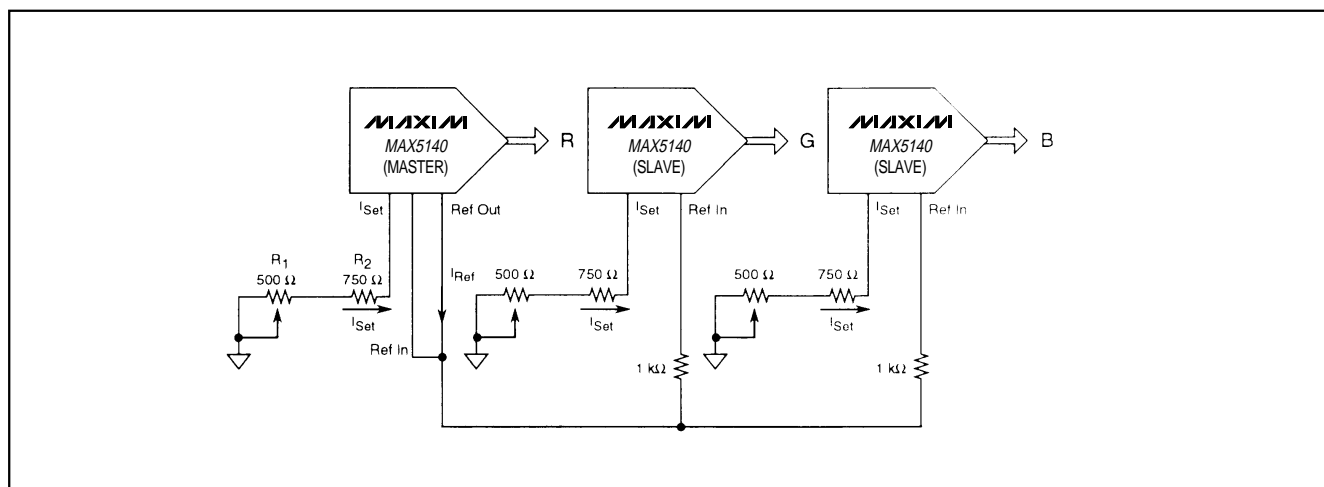
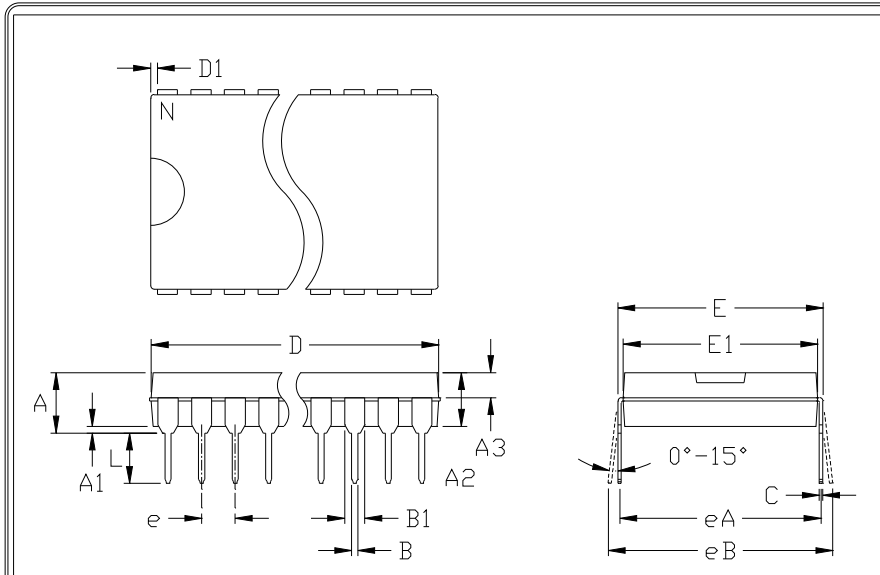

Figure 8. Typical RGB Graphics System

8-Bit, Ultra-High-Speed DAC

Package Information



	INCHES		MILLIMETERS	
	MIN	MAX	MIN	MAX
A	---	0.200	---	5.08
A1	0.015	---	0.38	---
A2	0.125	0.175	3.18	4.45
A3	0.055	0.080	1.40	2.03
B	0.016	0.020	0.41	0.51
B1	0.045	0.065	1.14	1.65
C	0.008	0.012	0.20	0.30
D1	0.050	0.090	1.27	2.29
E	0.600	0.625	15.24	15.88
E1	0.525	0.575	13.34	14.61
e	0.100	---	2.54	---
eA	0.600	---	15.24	---
eB	---	0.700	---	17.78
L	0.120	0.150	3.05	3.81

	INCHES		MILLIMETERS		N	MO015
	MIN	MAX	MIN	MAX		
D	1.230	1.270	31.24	32.26	24	AA
D	1.430	1.470	36.32	37.34	28	AL
D	2.025	2.075	51.44	52.71	40	AM

- NOTES:
1. D&E DO NOT INCLUDE MOLD FLASH
 2. MOLD FLASH OR PROTRUSIONS NOT TO EXCEED .15mm (.006")
 3. LEADS TO BE COPLANAR WITHIN .102mm (.004")
 4. CONTROLLING DIMENSION: MILLIMETER
 5. SIMILAR TO JEDEC MO015-XX AS SHOWN IN ABOVE TABLE
 6. N = NUMBER OF PINS



PACKAGE FAMILY OUTLINE: PDIP .600"

1/1

21-0044 A
DOCUMENT CONTROL NUMBER REV

Maxim cannot assume responsibility for use of any circuitry other than circuitry entirely embodied in a Maxim product. No circuit patent licenses are implied. Maxim reserves the right to change the circuitry and specifications without notice at any time.

12 Maxim Integrated Products, 120 San Gabriel Drive, Sunnyvale, CA 94086 408-737-7600

© 1998 Maxim Integrated Products

Printed USA

MAXIM is a registered trademark of Maxim Integrated Products.