

DATA SHEET

SAA1501T Battery charge level indicator

Objective specification
File under Integrated Circuits, IC11

December 1994

Philips Semiconductors



PHILIPS

Battery charge level indicator

SAA1501T

FEATURES

- High level of integration to allow assembly in intelligent battery packs
- Accurate charge and discharge account
- Large dynamic range of charge and discharge currents
- Independent settings of charge and discharge efficiency
- 2 V minimum supply voltage (2 cell operation)
- Temperature protection of batteries during charging
- Temperature controlled self-discharge
- Accurate charge current regulation
- Two charge amount display modes, LCD and LED.

GENERAL DESCRIPTION

The SAA1501T is intended to be used as a battery monitor and charge current control circuit in rechargeable battery systems.

The SAA1501T is processed in BiCMOS technology where the benefits of mixed bipolar and CMOS technology is fully utilized to achieve high accuracy measurements and digital signal processing in the same device. The general function of the integrated circuit is a Coulomb counter. During battery charging, the charge current and charge time are registered in a Coulomb counter. During discharge, the discharge current and time are recorded. The momentary charge amount of the batteries can be displayed either on an LCD screen or on an LED bargraph. Using the SAA1501T, intelligent batteries or intelligent battery powered systems can be easily designed with only a few external components.

QUICK REFERENCE DATA

SYMBOL	PARAMETER	CONDITIONS	MIN.	TYP.	MAX.	UNIT
V_{CC}	supply voltage		2.0	3.0	4.3	V
I_{CC}	supply current	$V_{CC} = 3\text{ V};$ $I_c = I_d = 60\ \mu\text{A}$	–	1.2	1.7	mA
I_{CCstb}	supply current in standby mode	$V_{CC} = 3\text{ V};$ $V_{CSI} = V_{DSI} = 0\text{ V}$	–	–	100	μA
f_{osc}	fixed oscillator frequency	$C_{osc} = 820\text{ pF};$ $R_{ref} = 51.5\text{ k}\Omega$	–	4.2	–	kHz
$V_{i(s)}$	input sense voltage (pins 9 and 10)		0	–	$V_{CC} - 1.6$	V
T_{amb}	operating ambient temperature		0	–	+70	$^{\circ}\text{C}$

ORDERING INFORMATION

TYPE NUMBER	PACKAGE		
	NAME	DESCRIPTION	VERSION
SAA1501T	SO24	plastic small outline package; 24 leads; body width 7.5 mm	SOT137-1

Battery charge level indicator

SAA1501T

BLOCK DIAGRAM

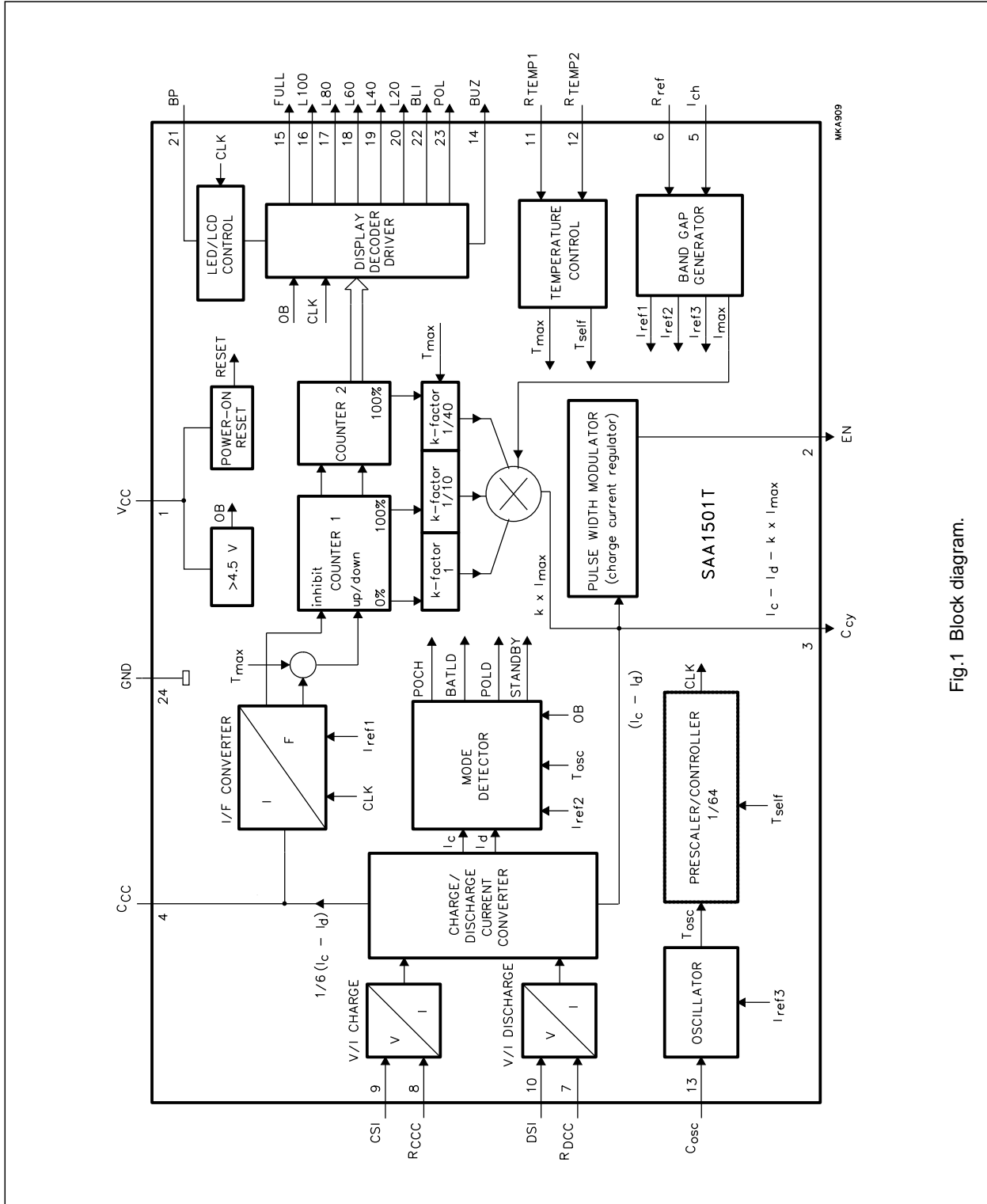

Fig.1 Block diagram.

Battery charge level indicator

SAA1501T

PINNING

SYMBOL	PIN	DESCRIPTION
V _{CC}	1	supply voltage
EN	2	enable output
C _{cy}	3	duty cycle capacitor output
C _{CC}	4	charge counter capacitor output
I _{ch}	5	maximum average charge current setting input
R _{ref}	6	current reference resistor input
R _{DCC}	7	discharge current conversion resistor input
R _{CCC}	8	charge current conversion resistor input
CSI	9	charge sense input
DSI	10	discharge sense input
R _{TEMP1}	11	temperature sensing resistor 1 input
R _{TEMP2}	12	temperature sensing resistor 2 input
C _{osc}	13	oscillator capacitor input
BUZ	14	buzzer output
FULL	15	battery full indication output
L100	16	100% segment indication output
L80	17	80% segment indication output
L60	18	60% segment indication output
L40	19	40% segment indication output
L20	20	20% segment indication output
BP	21	LCD back plane drive
BLI	22	battery low indicator LED output
POL	23	power-on LED output
GND	24	power ground

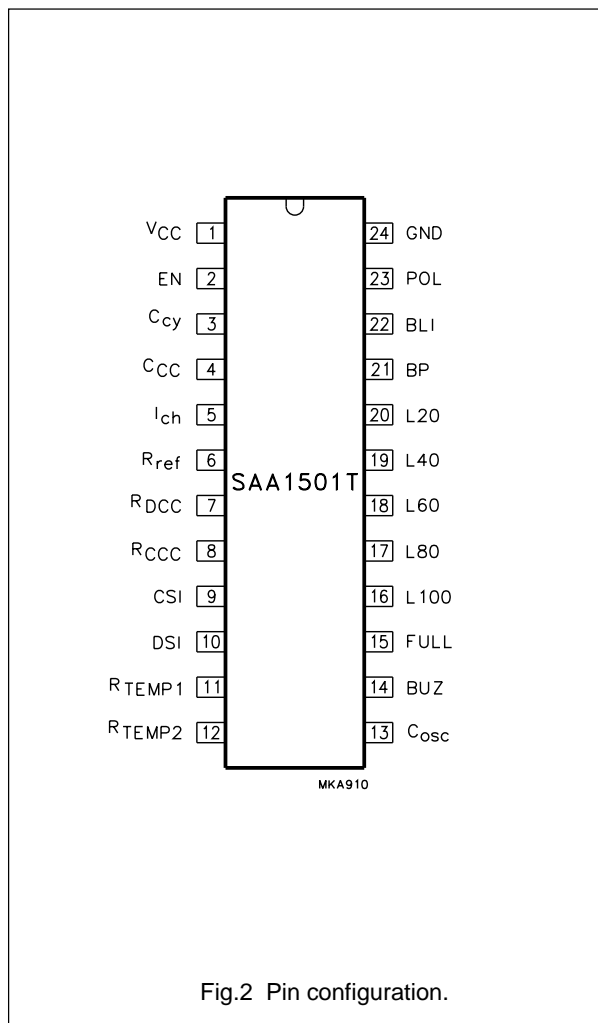

Battery charge level indicator

SAA1501T

FUNCTIONAL DESCRIPTION

The most important function of the SAA1501T is the charge account in rechargeable battery systems. Both NiCd and NiMH batteries in all sizes can be used. The system can operate alone as a charge monitor with a charge amount display function or, can operate in conjunction with a charger. If the SAA1501T operates together with a charger, it delivers a control signal at output EN, for charge current regulation or for battery voltage regulation.

Fast charging systems and charge current regulation

The SAA1501T is especially designed to be used in fast charging systems. In fast charging systems, the charge time is lowered by raising the charge current. Signal EN controls the charger current. The counters register the state of charge of the batteries and at the 80% level the charge current is reduced via a smaller duty cycle regulation of signal EN. The second (slow) level fully charges the batteries which is not possible with the first (fast) level. After the slow charge mode the counter switches over to an even smaller duty cycle of EN and thus enters the third (trickle) charge mode, to overcome the self-discharge of the batteries.

Current sensing and charge account

The charge current is sensed by means of a very low resistance (e.g. 70 mΩ) sense resistor R_{sc} (see Fig.8) to save power at high charge rates. Via the V/I charge converter and external resistor R_{CCC} (see Fig.8), the sensed voltage is converted into a charge current I_c (the same is applicable for the discharge current). In the I/F converter the charge current is converted into a frequency for up-counting the counter. For the discharge current (I_d) the converted frequency is used for down-counting. The up and down counting is registered in counters CNT1 and CNT2, depending on the actual charge and discharge current levels of the batteries. This is called dynamic charge account.

Charge display

The charge amount represented by the Coulomb counter can be displayed via an LCD screen or via an LED bargraph. If the charge amount is reduced to 0%, the battery low indicator (BLI) LED is turned on at the end of a battery discharge session. A flashing BLI, in combination with a repeating buzzer alarm, informs the user about the low charge state. A new charge session should then be started.

Protections

In the temperature control block, the absolute temperature is used as a protection to end the fast charge cycle. Fast charging at high temperature is not permitted because of degradation of the battery cells. If the batteries are disconnected, an open-battery condition is recognized and the SAA1501T enters the standby mode.

Mode detection

The mode detector detects whether there are any charge or discharge currents, whether the system is powered, whether loads are connected or whether the system is in the standby mode. If power is connected, the power-on LED (POL) is on. In the standby mode, the Coulomb counter will count down in accordance with the self-discharge speed of the batteries, which is temperature controlled. The following subsections describe the various blocks of the block diagram in more detail.

Supply and reference

During the period when V_{CC} rises from 0 V to the internal reset level, all counters are reset. The internal reset is released before V_{CC} reaches 1.7 V. The operating supply voltage ranges from 2 V to the open battery level of 4.3 V (min). The characteristics are guaranteed at $V_{CC} = 3$ V. In order to protect the SAA1501T against high supply voltages during open battery in a flyback converter, a voltage clamp circuit is made active at 6.35 V (typ). The clamping current must not exceed 80 mA. A band gap reference block is included to generate accurate voltages i.e. for the oscillator. Moreover, together with R_{ref} , accurate currents are generated which are used in the I/F and V/I converters and the oscillator block. In the standby mode only the oscillator and the digital parts are active to limit the discharge current of the batteries to a current level of less than 100 mA. The circuits that are needed temporarily are switched on and off during standby (see "Timing characteristics" t_{som}).

Voltage-to-current charge and discharge

In the V/I converter, the input charge current is translated into acceptable levels for the circuit. The conversion formula is:

$$I_c = \frac{(I_{charge} \times R_{sc})}{R_{CCC}}; \text{ where } R_{CCC} > R_{sc} \text{ (see Fig.7)}$$

Battery charge level indicator

SAA1501T

With R_{CC} , the charge efficiency can be manipulated depending on the charge level. The restriction of the SAA1501T is a maximum average charge current of $60 \mu\text{A}$ and a minimum momentary charge current of $0.6 \mu\text{A}$. The same formula is applicable for the discharge current. The discharge efficiency can now also be changed by R_{DCC} depending on the discharge current levels, but independent of the charge current. As both sense levels are referenced to ground, the sensing elements could be combined into one. The outputs are used combined as $\frac{1}{6} \times (I_c - I_d)$ in the I/F converter and combined as $(I_c - I_d)$ in the pulse width modulator block and made separately available in the mode detector. The conversion is made lower by a factor of 6 in the I/F converter block, thereby enabling the use of poor leakage capacitors on pin 4. All V/I converter pins are sensitive to capacitive loading ($C_{\text{out}} \times R_{\text{conv}} < 1 \text{ ms}$), the conversion resistors should be mounted as close as possible to the output pins.

I/F converter

This block produces up-counts while charging and down-counts while discharging. The I/F converter translates the charge/discharge currents into a frequency. This frequency is determined by

$$f = \frac{(I_{c(d)} \times R_{\text{sense}} \times 6)}{(C_{\text{CC}} \times \Delta V_{\text{osc}} \times R_{\text{CC}}(R_{\text{DCC}}))}$$

During the time period 't', the charge current, expressed as a 'Charge Parcel', will be counted in the Coulomb counters (CNT1 and CNT2). During discharge the 'Charge Parcel' is the product of the discharge current and the 't' from the I/F converter generated frequency. The momentary contents of the Coulomb counter is a multiple of the 'Charge Parcels'.

Coulomb counters CNT1 and CNT2

The SAA1501T has been designed for average maximum charge and discharge current levels of 5 C and minimum charge and discharge current levels of 0.05 C. This means that counter CNT1 will be full, or empty, after a minimum time period of 12 minutes at maximum charge and discharge currents at the recommended oscillator frequency. Higher charge and discharge rates than 5 C are possible, but only by changing the oscillator frequency. It should be noted that the self-discharge time and the display functions are influenced by a higher oscillator frequency. The SAA1501T enables top-up charging in order to account for the decrease of charge efficiency at high charge rates. The SAA1501T switches to the slow charge mode at full recognition when CNT1 is at its maximum. As soon as the batteries are completely full (when CNT2 is at its maximum), the SAA1501T switches

to the trickle charge mode to overcome the self-discharge of the batteries. The top-up charge volume of $\text{CNT2} = 0.2 \times \text{CNT1} = 0.2 \text{ C}$ (where Q is rated as Ampere hours of the battery). The slow and trickle charge current levels are dependent on the k-factor. Signal EN controls the external charger e.g. TEA1400 (see Fig.8). When an LED bargraph display is used, the LED currents are also considered as a battery discharge current, and therefore influence the duty cycle of the charge current regulation signal EN. The SAA1501T also enables temperature protection. In the event that the battery temperature exceeds a certain maximum temperature level ($T_{\text{battery}} > T_{\text{max}}$), which can be set by an external NTC resistor, the SAA1501T switches to the slow charge mode. In the standby mode (self-discharge mode), which is recognized by the SAA1501T in the mode detector when both the charge and discharge currents are zero ($I_c = I_d = 0$), the self-discharge of the batteries is registered by counting down in 200 days (based on $f_{\text{osc}} = 4 \text{ kHz}$) if $T_{\text{battery}} < T_{\text{self}}$ or in 100 days (based on $f_{\text{osc}} = 4 \text{ kHz}$) if $T_{\text{battery}} > T_{\text{self}}$. T_{self} is also set by means of an external NTC resistor.

Band gap generation

From the band gap voltage block, two reference voltages are derived V_{ref} and V_{max} . Voltage V_{ref} at pin R_{ref} sets the reference currents, I_{ref1} (I/F converter); I_{ref2} (mode detector) and I_{ref3} (oscillator). Voltage V_{max} sets the current I_{max} which is used in the pulse width modulation block to accurately control the charge current.

Charge current regulation

While charging, the SAA1501T produces a charge current regulation signal EN in the pulse width modulation block which is used for controlling an external charger. This digital signal EN is derived from the signal produced at pin C_{cy} . The duty cycle is determined by

$$\delta = \frac{k \times I_{\text{max}}}{I_c - I_d}$$

in which the value of k depends on the state of the counters CNT1 and CNT2:

CNT1 is not full; $k = 1$ (fast charging).

CNT1 is full; CNT2 is not full; $k = 0.1$ (slow charging).

CNT1 and CNT2 are full; $k = 0.025$ (trickle charging).

Battery charge level indicator

SAA1501T

Mode detector

This block differentiates between the available modes of operation. The modes are given below:

- Charge mode; power charge (POCH).
- Discharge mode; battery load (BATLD).
- Power load mode (POLD); the batteries are charged while the load is also active.
- Self discharge mode; (STANDBY).

To detect power in a regulated system (see Fig.8) the EN signal is used for sensing. The POCH mode is recognized when the converted charge current $I_c > I_{ref2}$ (when in the power mode, change of mode can only be recognised if EN is HIGH). The BATLD mode is recognized when $I_d > I_{ref2}$; the POLD mode is recognized when $I_c > I_{ref2}$ and $I_d > I_{ref2}$; the standby mode is recognized when $I_c < I_{ref2}$ and $I_d < I_{ref2}$. In the standby mode, if the advised frequency (4 kHz) is applied, it takes 0.5 s to determine another mode (in all other modes, a change of mode is sensed continuously). In all other modes an eventual change of mode is done continuously. To save supply current during standby, the V/I converters are switched off. With the specific fixed intervals, the SAA1501T checks whether power or load is connected again. This checking is synchronized by the sensing signal of the V/I converters. The SAA1501T can handle a DC charge current as well as a discontinuous charge current (SMSP charger). The load current can also be DC or interrupted, e.g. produced by a motor. The digital filtering of both signals, to overcome faulty mode detections, restricts the conditions in which power and load are recognized. Because of the very sensitive input detection level of the mode detector for a charge current (power) in combination with the high interference levels of motor driving, the detection level for power ($I_c > I_{ref2}$) is raised by a factor of 25 when the batteries are loaded.

Oscillator

As the oscillator has to operate in all modes, including the standby mode, the current consumption of the oscillator must be very low. The same applies for the band gap generator block, because the band gap delivers accurate reference voltages and currents to the oscillator block. Apart from the low current consumption, the accuracy of the period time is important. The period time of the oscillator is:

$$t_{osc} = 2 \times C_{osc} \times \frac{(V_H - V_L)}{I_{ref3}} = 5.6 \times C_{osc} \times R_{ref}$$

Prescaler/controller

In the prescaler, a new system clock is created (CLK) which is used for all timing blocks. Many frequencies are derived from the basic oscillator at the standard frequency of 4 kHz ($1/T_{osc}$), such as the self-discharge times and the modulation frequency for the buzzer, the drive voltage frequency for the LCD screen and the pulse trains for temperature measurements and power/load sensing measurements in the mode detector.

Temperature

In the temperature control block two temperature measurements are performed. In order to switch off fast charging when the battery temperature exceeds an adjustable maximum temperature (T_{max}), a maximum temperature measurement is performed. A second temperature measurement is performed in the standby mode. This temperature measurement is input to the temperature control block to switch over the self-discharge rate from a count down of 200 days (based on $f_{osc} = 4$ kHz) if $T_{battery} < T_{self}$, to a count down rate of 100 days (based on $f_{osc} = 4$ kHz) if $T_{battery} > T_{self}$. In all modes the temperature is measured periodical. The temperature circuit which controls the above mentioned functions is a bridge configuration synthesis, as illustrated in Fig.3.

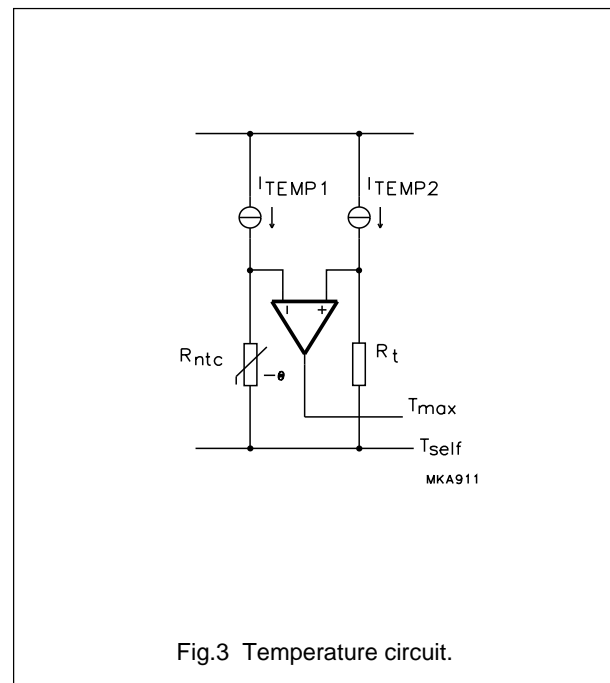

Fig.3 Temperature circuit.

Battery charge level indicator

SAA1501T

Display decoder driver

The counters are used to output the battery charge amount via a decoder and driver stage to the display outputs L100, L80, L60, L40 and L20 to drive an LCD screen or an LED bargraph. A 64 Hz (based on $f_{osc} = 4 \text{ kHz}$) block signal at output BP (back plane) must be connected to the back plane of the LCD bar. If pin BP is connected to ground, the display outputs L20 to L100 will produce signals for an LED bargraph. Output signal POL (power-on LED) indicates when the batteries are in the charge mode. When the counter is not at its maximum state, POL is on and flickers at 2 Hz (based on $f_{osc} = 4 \text{ kHz}$) when the counter is at its maximum. The waveforms illustrated in Fig.4 depict operation of the monitor display. The outputs BLI (battery low indication), BUZ (buzzer) and FULL indicate the extreme status (empty or full) of the counters and the batteries. The waveforms of the signals BLI and BUZ if one switches over from BATLD to standby when BLI is active, are given in Fig.4.

The BLI sequence is as follows. If during discharge the charge state falls below 0%, the red BLI LED is turned on. Changing mode from discharge to standby means that the BLI LED and the buzzer (BUZ) are activated as indicated in Fig.4. If after a 0% passing recharge is activated, the red BLI LED is turned on again for as long as the counter remains below 10%. Switch-over in the 0 to 10% range to standby will activate BLI and BUZ again.

The LEDs of the LED bargraph are activated as a result of each operational mode change, starting with a step-up pattern. Step-up means that LEDs are activated successively one after the other, in accordance with the charge status each $\frac{1}{8} \text{ s}$ (based on $f_{osc} = 4 \text{ kHz}$). After the step-up, the LEDs will be on for 8 s (based on $f_{osc} = 4 \text{ kHz}$), except for the POCH mode, where the LEDs will be on continuously to inform the user about the charge state of the batteries. The LCD display is, apart from the LED mode, always visible.

Figure 5 shows the legend for Fig.6. Figure 6 shows the operation of the monitor display.

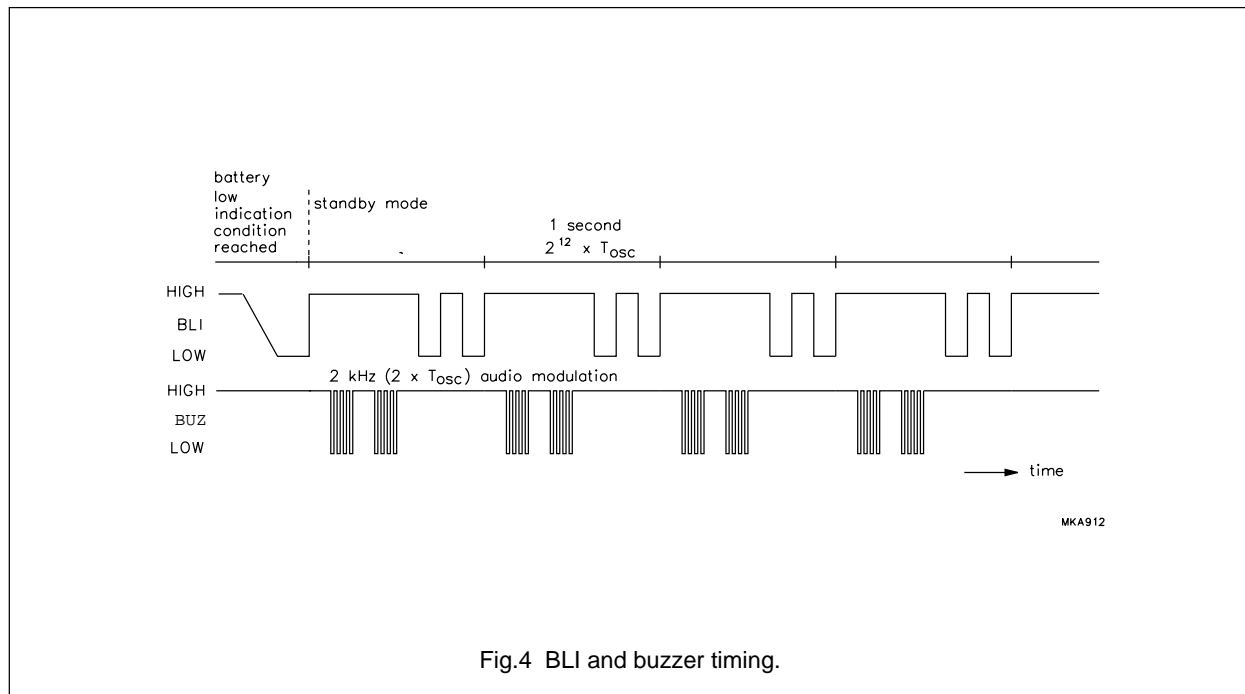

Fig.4 BLI and buzzer timing.

Battery charge level indicator

SAA1501T

Open battery protection

Open battery protection is active when $V_{CC} = 4.5$ V (typ.). The SAA1501T will then react as if the system is in the standby mode. This means that the LEDs are turned off in the LED mode, in the LCD mode the flickering is stopped and the enable pin (EN) is switched to floating.

Testing

A user test facility is built-in for checking if the LCD and/or LED displays are mounted correctly. Pin R_{CC} is used as

a test pin. Raising the voltage above 1 V during the set-up time will activate the test. The test mode can only be started in the standby mode. In the test mode all counters are reset and will be active successively in the sequence BLI, L20, L40, L60, L80, L100 and FULL with an interval period determined by T_{OSC} . The test mode can be exited via the following methods:

Power-on; the Coulomb counter retains the latest data displayed.

Automatically after the test cycle time; the Coulomb counter is reset.

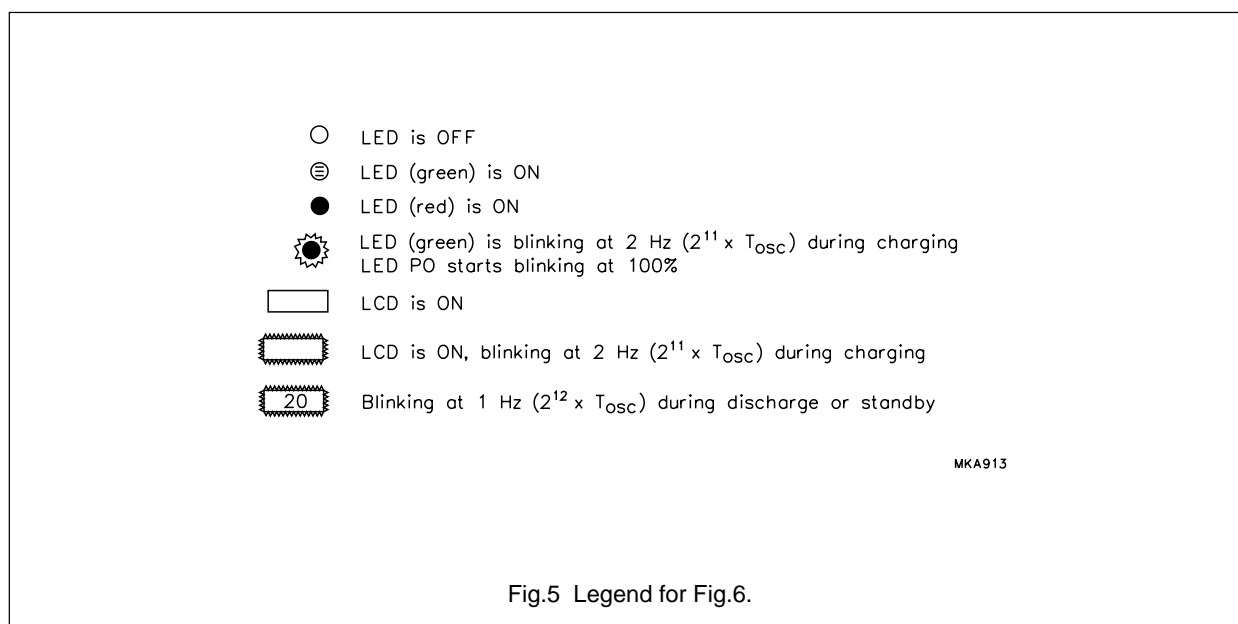

Battery charge level indicator

SAA1501T

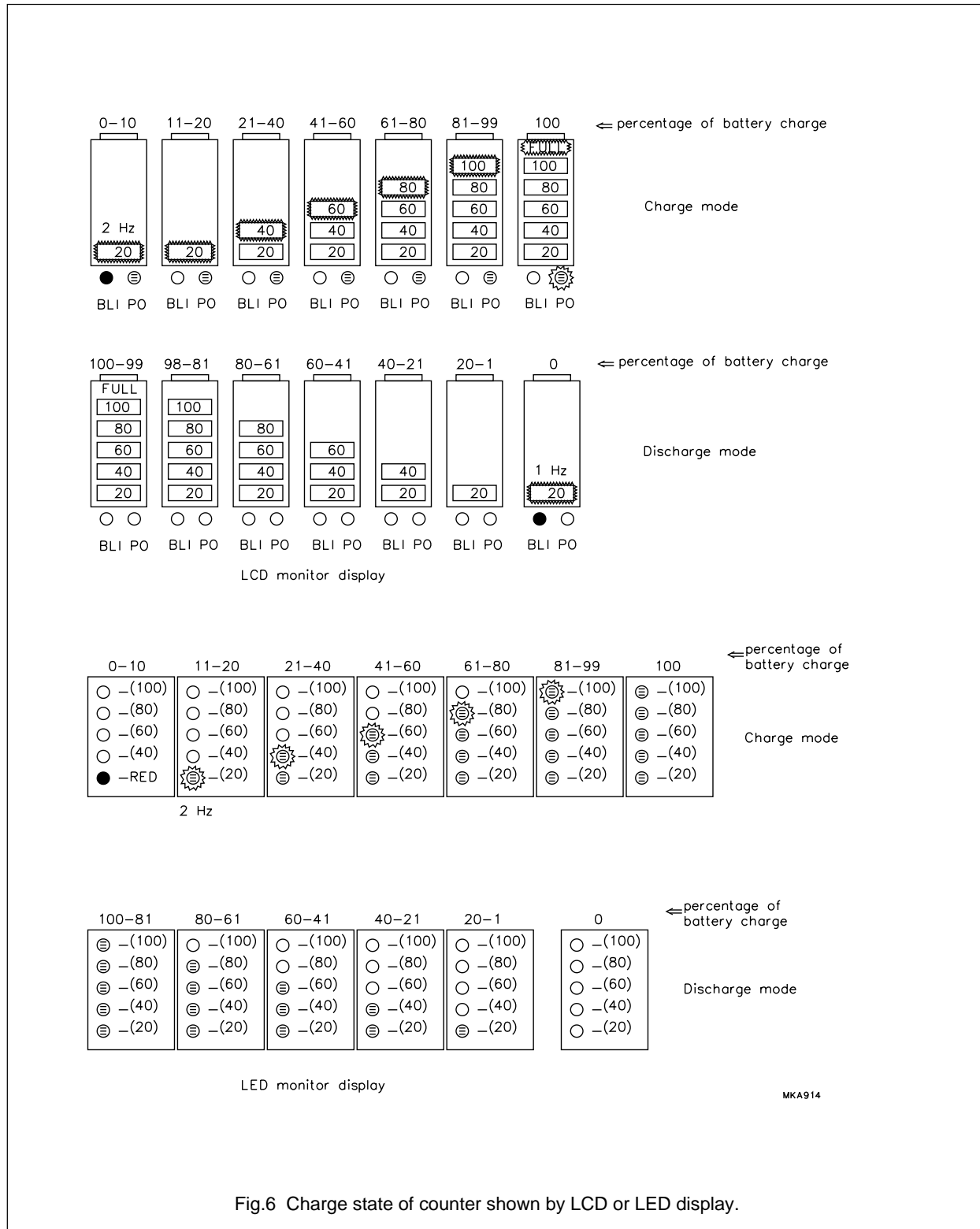

Fig.6 Charge state of counter shown by LCD or LED display.

Battery charge level indicator

SAA1501T

LIMITING VALUES

In accordance with the Absolute Maximum Rating System (IEC 134). All voltages with respect to GND (pin 24); input currents are positive; pins 5, 6 and 21 are not allowed to be voltage driven; the voltage ratings are valid provided other ratings are not being violated.

SYMBOL	PARAMETER	CONDITIONS	MIN.	MAX.	UNIT
V_{CC}	supply voltage		-0.5	+5.5	V
V_{n1}	input voltage at pins 9 to 12		-0.5	+1.0	V
V_{n2}	input voltage at pins 2 to 4, 13 to 20, 22 and 23		-0.5	V_{CC}	V
ΔV	voltage difference between pins 10 and 7 and between pins 9 and 8		-2.0	+2.0	V
I_{CC}	supply current		-	80	mA
I_{GND}	power ground supply current		-	-80	mA
I_n	supply current at pins 5 to 8		-	-1	mA
P_{tot}	total power dissipation	$T_{amb} = 70\text{ }^{\circ}\text{C}$	-	0.75	W
T_{stg}	storage temperature		-55	+150	$^{\circ}\text{C}$
T_j	junction temperature		-	+150	$^{\circ}\text{C}$
T_{amb}	operating ambient temperature		-10	+75	$^{\circ}\text{C}$

QUALITY SPECIFICATION

In accordance with SNW-FQ-611 part E. The numbers of the quality specification can be found in the "Quality Reference Handbook". The Handbook can be ordered using the code 9398 510 63011.

THERMAL CHARACTERISTICS

SYMBOL	PARAMETER	VALUE	UNIT
$R_{th\ j-a}$	thermal resistance from junction to ambient in free air	75	K/W

Battery charge level indicator

SAA1501T

CHARACTERISTICS

$V_{CC} = 3\text{ V}$; $T_{amb} = 25\text{ °C}$; $R_{ref} = 51.5\text{ k}\Omega$ (0.1%); $C_{osc} = 820\text{ pF}$ (0.1%); $R_{CCC} = R_{DCC} = 3.65\text{ k}\Omega$ (0.1%); $R_{max} = 3.48\text{ k}\Omega$ (0.1%); $I_{ref} = V_{ref}/R_{ref}$; $I_{max} = V_{max}/R_{max}$; the minimum and maximum values are 4 sigma limits; unless otherwise specified.

SYMBOL	PARAMETER	CONDITIONS	MIN.	TYP.	MAX.	UNIT
Supply						
V_{CC}	supply voltage	note 1	2.0	3.0	4.3	V
$V_{CC(ir)}$	supply voltage internal reset		–	1.2	1.7	V
I_{CC}	supply current	$I_c = I_d = 60\text{ }\mu\text{A}$	0.6	–	1.7	mA
I_{CCstb}	supply current in standby mode	$V_{CSI} = V_{DSI} = 0\text{ V}$	–	–	100	mA
V_{ref}	reference voltage	note 2	204	211	217	mV
I_{ref}	reference current	notes 1 and 2	3.5	–	8	μA
V_{max}	maximum voltage	note 2	204	211	217	mV
TC	temperature coefficient of reference voltage	$T = 0\text{ to }100\text{ °C}$	0	25×10^{-6}	100×10^{-6}	°C
V_{clamp}	clamping level voltage	$I_{CC} = 50\text{ mA}$	5.8	6.3	6.8	V
Voltage-to-current charge/discharge						
I_4	voltage-to-current charge/discharge current accuracy	$V_9 = 7\text{ mV}$; $V_4 = 1.5\text{ V}$	–259	–324	–389	nA
		$V_{10} = 7\text{ mV}$; $V_4 = 1.5\text{ V}$	262	328	394	nA
		$V_9 = 200\text{ mV}$; $V_4 = 1.5\text{ V}$	–8.93	–9.13	–9.32	μA
		$V_{10} = 200\text{ mV}$; $V_4 = 1.5\text{ V}$	8.93	9.13	9.32	μA
I_3	voltage-to-current charge/discharge current accuracy	$V_9 = 7\text{ mV}$; $R_{max} = 400\text{ k}\Omega$; $k = 0.025$	–1.55	–1.94	–2.32	μA
		$V_{10} = 7\text{ mV}$; $R_{max} = 400\text{ k}\Omega$; $k = 0.025$	1.57	1.97	2.36	μA
		$V_9 = 200\text{ mV}$; $R_{max} = 400\text{ k}\Omega$; $k = 0.025$	–53.5	–54.7	–56	μA
		$V_{10} = 200\text{ mV}$; $R_{max} = 400\text{ k}\Omega$; $k = 0.025$	53.5	54.7	56	μA
I_4/I_3	relative current accuracy of voltage-to-current in charge counter capacitor	$V_9 = V_{10} = 200\text{ mV}$	–	1.0	2.5	%
$V_{i(s)}$	input sense voltage at pins 9 and 10	$V_{CC(max)} = 3.7\text{ V}$; note 1	0	–	$V_{CC} - 1.6$	V
		$3.7 < V_{CC} < 4.4\text{ V}$; note 1	–	–	2.1	V
$I_{o(s)}$	DC output sense current (pins 8 and 7)		0.6	–	60	μA
V_{os}	offset voltage		–	–	1.8	mV

Battery charge level indicator

SAA1501T

SYMBOL	PARAMETER	CONDITIONS	MIN.	TYP.	MAX.	UNIT
I/F converter						
a	multiplication factor for I_{ref1}	$I_{ref1} = a \times I_{ref}$ (where a is constant); $V_4 = 1.26$ V; idle mode	2.35	2.5	2.65	
V_{clamp}	clamping voltage (pin 4)	$I_c = 0$; $I_d = 60$ μ A; $I_4 = 10$ μ A	0.7	0.9	1.1	V
$V_{CC(H)}$	HIGH level reference voltage (pin 4)		1.58	1.66	1.74	V
$V_{CC(L)}$	LOW level reference voltage (pin 4)		1.26	1.33	1.4	V
Pulse width modulator						
ACC	accuracy for I_{max} at C_{cy}	$15 < I_{max} < 60$ μ A	–	–	± 3	%
I_{max}	maximum DC current	$I_{max} = V_{max}/R_{max}$; note 1	0.6	–	60	mA
I_d/I_{max}	k factor	$k = 1$; $V_d = 1.5$ V; idle mode	0.95	0.98	1.01	
		$k = 0.1$; $V_d = 1.5$ V; idle mode	0.094	0.099	0.104	
		$k = 0.025$; $V_d = 1.5$ V; idle mode	0.023	0.025	0.027	
V_{CCY}	start up-clamping voltage (pin 3)	$I_d = 10$ μ A; $I_c = 0$	0.7	0.9	1.1	V
V_{CCY}	clamping voltage (pin 3)	open-circuit at pin 3; pin 5 = V_{CC} ; $\pm(I_c - I_d) = 60$ μ A	–	–	$V_{CC} - 0.6$	V
$V_{CCY(H)}$	HIGH level switching voltage		1.60	1.77	1.86	V
$V_{CCY(L)}$	LOW level switching voltage		1.28	1.32	1.37	V
I_z	3-state enable current	$V_2 = 1.5$ V	–	–	1	μ A
Mode detector						
I_{ref2}	mode detection level at pins 7 and 8	$I_{ref2} \geq e \times I_{ref}$ (where e is constant)	–	$0.15I_{ref}$	–	
I_{ref4}	mode detection level at pin 7	$I_{ref4} \geq I_{ref2}$; in modes POLD and BATLD	–	$25I_{ref2}$	–	
Oscillator (pin 13)						
Q_c	charge amount	$I_{ref1(sink)} \times T_{clk}$	142	150	158	nC
Q_d	discharge amount	$I_{ref1(source)} \times T_{clk}$	142	150	158	nC
ΔQ	difference between charge and discharge charge amount		0.95	1.0	1.05	
b	multiplication factor for I_{ref3}	$I_{ref3} = b \times I_{ref}$ (where b is constant)	–	0.75	–	
ΔV_{osc}	voltage swing HIGH-to-LOW transition		–	440	–	mV

Battery charge level indicator

SAA1501T

SYMBOL	PARAMETER	CONDITIONS	MIN.	TYP.	MAX.	UNIT
f_{osc}	oscillator frequency		3.9	4.3	4.7	kHz
Temperature control (pins 11 and 12)						
V_i	input voltage		0	–	900	mV
I_{TEMP2}/I_{TEMP1}	detection at T_{max}	$V_{11} = V_{12} = 300$ mV	9.7	10.0	10.3	
I_{TEMP2}/I_{TEMP1}	detection at T_{self}	$V_{11} = V_{12} = 300$ mV	15	16	17	
c	multiplication factor for I_{TEMP1}	$I_{TEMP1} = c \times I_{ref}$ (where c is constant); $V_{TEMP1} = V_{TEMP2} = 300$ mV	0.45	0.54	0.63	
d	multiplication factor for I_{TEMP2}	$I_{TEMP2} = d \times I_{ref}$ (where d is constant); $V_{TEMP1} = V_{TEMP2} = 300$ mV	4.5	5.4	6.3	
Open battery protection						
$V_{CC(ob)}$	open-battery level voltage		4.3	4.5	4.65	V
Testing						
V_{test}	test level voltage		1.0	–	2.0	V
Display decoder driver						
I_{OL1}	LOW level output current (pin 20 LED), (LED 20 is on)	$V_{OL} = 0.6$ V; L40 to L100 off; $V_{CC} = 2.4$ V	7	10	12	mA
I_{OBP}	output LED sense current (pin 21 LED), (LED 20 is on)	$V_{OBP} = 0.1$ V; L40 to L100 off; $V_{CC} = 2.4$ V	63	82	100	μ A
$I_{LED(CF)}$	LED current compensation factor	I_{OL1}/I_{OBP} ; $V_{CC} = 2.4$ V	110	121	132	
I_{OL2}	LOW level output current (pins 20 to 16 LED), (all LEDs are on)	all LEDs on; $V_{OL} = 0.7$ V; $V_{CC} = 2.8$ V	7.5	11	14	mA
$I_{OBP(tot)}$	total output sense current (pins 21)	$V_{OBP} = 0.1$ V; $V_{CC} = 2.8$ V; L20 to L100 on	350	452	560	μ A
$I_{LED(CF)}$	LED current compensation factor	$5I_{OL2}/I_{OBP(tot)}$	115	125	135	
I_{OL}	output current (pins 20 to 16 LCD)	$V_{OL} = 0.5$ V; $V_{CC} = 2.8$ V	350	480	640	μ A
$I_{OL(14,15)}$	LOW level output current (pins 14 and 15)	$V_{OL} = 0.4$ V; $V_{CC} = 2.4$ V	0.9	1.2	1.7	mA
$I_{OL(22,23)}$	LOW level output current (pins 22 and 23 LED)	$V_{OL} = 0.4$ V; $V_{CC} = 2.1$ V	7	10	12	mA
$I_{OL(21)}$	LOW level output current (pin 21 LCD)	$V_{OL} = 0.4$ V; $V_{CC} = 2.8$ V	572	849	1214	μ A
I_{OH}	HIGH level output current (pins 20 to 16 LED)	$V_{OH} = 2.4$ V; $V_{CC} = 2.8$ V	261	378	526	μ A
$I_{OH(21)}$	HIGH level output current (pin 21 LED)	$V_{OH} = 2.4$ V; $V_{CC} = 2.8$ V	239	378	565	μ A

Battery charge level indicator

SAA1501T

SYMBOL	PARAMETER	CONDITIONS	MIN.	TYP.	MAX.	UNIT
$V_{OH(14)}$	HIGH level output current (pin 14)	$V_{OH} = 2 \text{ V}; V_{CC} = 2.4 \text{ V}$	0.7	1.6	2.5	μA
$I_{OH(15)}$	HIGH level output current (pin 15)	$V_{OH} = 2 \text{ V}; V_{CC} = 2.4 \text{ V}$	0.99	1.67	2.69	mA
$I_{OH(22,23)}$	HIGH level output current (pins 22 and 23)	$V_{OH} = 2.4 \text{ V}; V_{CC} = 2.4 \text{ V}$	260	450	708	μA
I_{LO}	output leakage current (pin 21)	$V_{OH} = 0 \text{ to } V_{CC}$	–	–	± 1	μA

Notes

1. Not measured by the industrial measuring program, but guaranteed by design.
2. Internally detected from band gap generator.

Battery charge level indicator

SAA1501T

TIMING CHARACTERISTICS

SYMBOL	PARAMETER	CONDITIONS	VALUE
T_{osc}	oscillator cycle time	note 1	$T_{osc} = 2C_{osc} \times V_{osc}/I_{ref3}$
T_{clk}	clock cycle time		$64t_{osc}$
t_{som}	sense operation mode time	note 2	$1.5 \times 2^7 T_{osc}$
$t_{som(p)}$	sense operation mode period time	note 2	$2^{12} T_{osc}$
t_{rec}	recognition time	power; note 3	$>32t_{osc}$
		load; note 4	$>20t_{osc}$
t_{self}	self discharge counter time	$T_{battery} > T_{self}$ (100 days at $f_{osc} = 4$ kHz)	$2^{35} T_{osc}$
		$T_{battery} > T_{self}$ (200 days at $f_{osc} = 4$ kHz)	$2^{36} T_{osc}$
$t_{battery(s)}$	battery temperature measurement sense time		$2^7 T_{osc}$
$t_{battery(p)}$	battery temperature measurement period time		$2^{16} T_{osc}$
t_{su}	display test set-up time		$2^{11} T_{osc} < t < 1.5 \times 2^{18} T_{osc}$
t_{id}	interval display test time		$2^{10} T_{osc}$
t_{pd}	period display test time		$1.5 \times 2^{18} T_{osc}$
$t_{su:LED}$	LED set-up time		$2^9 T_{osc}$
$t_{LED(ON)}$	LEDs-on time	after change of mode (except POCH mode)	$2^{15} T_{osc}$
f_{BP}	drive voltage frequency for back plane		$2^{-4} T_{osc}$
f_{BUZ}	modulation frequency for auto buzzer		$\frac{1}{2} T_{osc}$

Notes

- $t_{osc} = 2C_{osc} \times \frac{V_{osc}}{I_{ref3}}$; where $V_{osc} = 440$ mV and $I_{ref3} = 0.75$.
- Applies to all converters and enable signal.
- For charge current AC or DC: $f > \frac{1}{2} f_{osc}$.
- For discharge current AC: $f > \frac{1}{4} f_{osc}$.

Battery charge level indicator

SAA1501T

APPLICATION INFORMATION

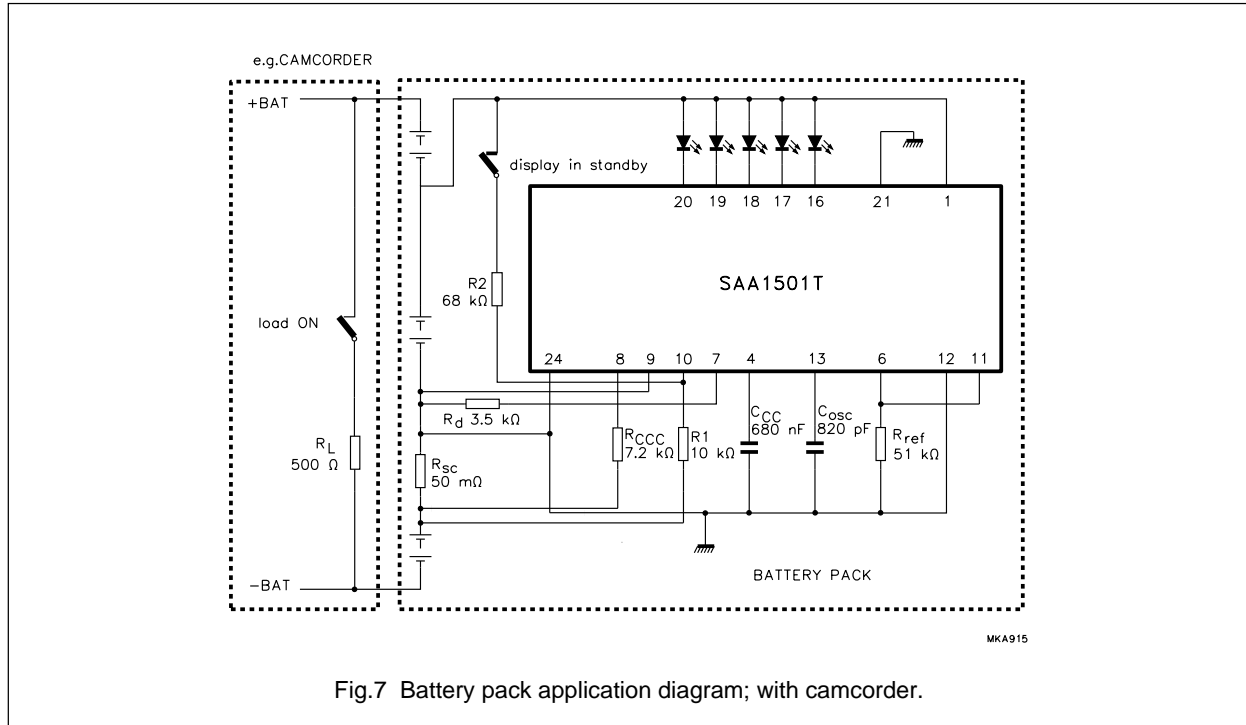

Fig.7 Battery pack application diagram; with camcorder.

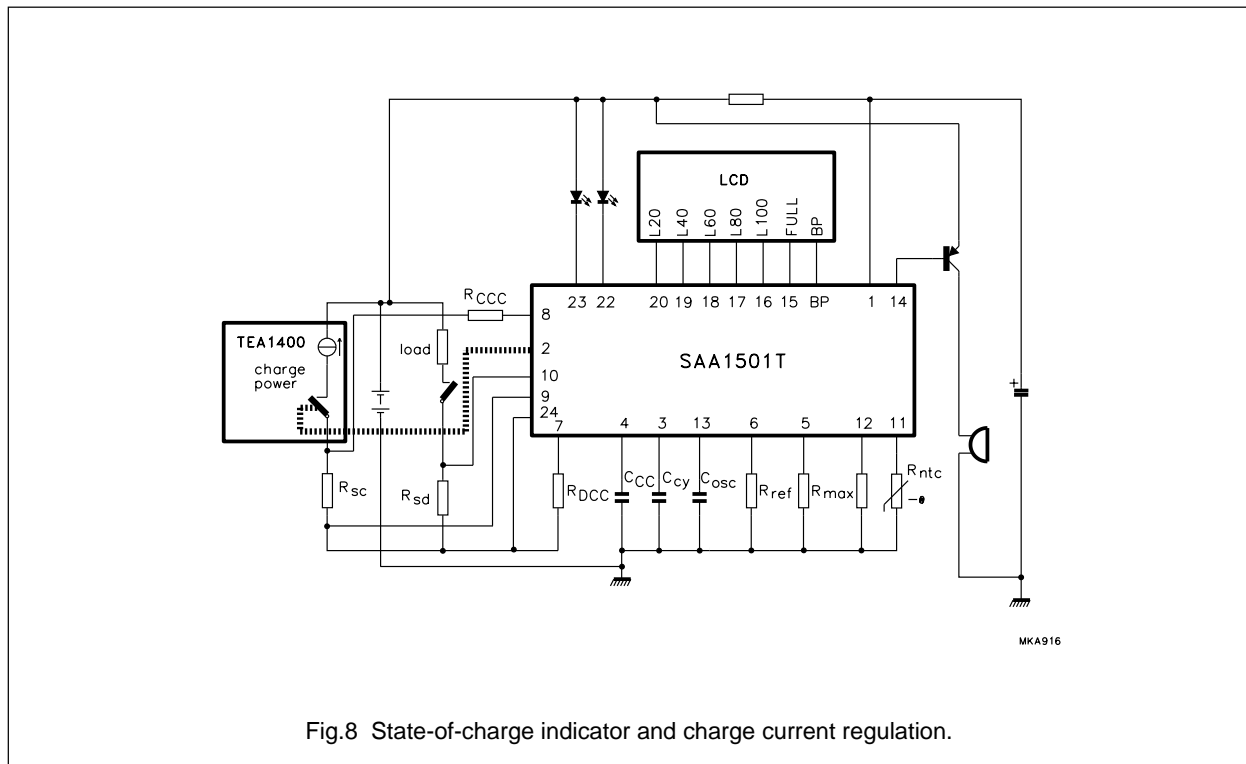
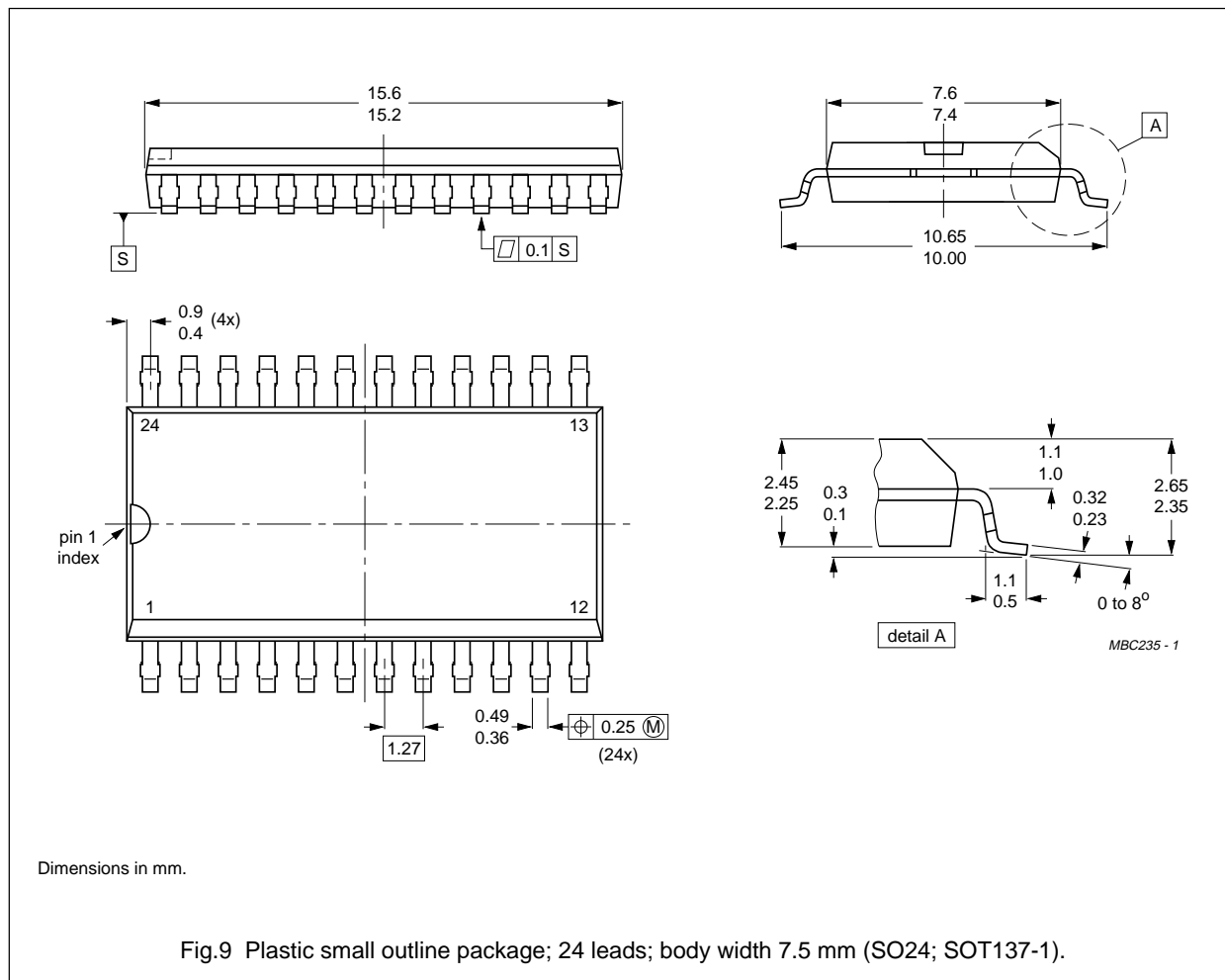

Fig.8 State-of-charge indicator and charge current regulation.

Battery charge level indicator

SAA1501T

PACKAGE OUTLINE



Battery charge level indicator

SAA1501T

SOLDERING

Plastic small-outline packages

BY WAVE

During placement and before soldering, the component must be fixed with a droplet of adhesive. After curing the adhesive, the component can be soldered. The adhesive can be applied by screen printing, pin transfer or syringe dispensing.

Maximum permissible solder temperature is 260 °C, and maximum duration of package immersion in solder bath is 10 s, if allowed to cool to less than 150 °C within 6 s.

Typical dwell time is 4 s at 250 °C.

A modified wave soldering technique is recommended using two solder waves (dual-wave), in which a turbulent wave with high upward pressure is followed by a smooth laminar wave. Using a mildly-activated flux eliminates the need for removal of corrosive residues in most applications.

BY SOLDER PASTE REFLOW

Reflow soldering requires the solder paste (a suspension of fine solder particles, flux and binding agent) to be

applied to the substrate by screen printing, stencilling or pressure-syringe dispensing before device placement.

Several techniques exist for reflowing; for example, thermal conduction by heated belt, infrared, and vapour-phase reflow. Dwell times vary between 50 and 300 s according to method. Typical reflow temperatures range from 215 to 250 °C.

Preheating is necessary to dry the paste and evaporate the binding agent. Preheating duration: 45 min at 45 °C.

REPAIRING SOLDERED JOINTS (BY HAND-HELD SOLDERING IRON OR PULSE-HEATED SOLDER TOOL)

Fix the component by first soldering two, diagonally opposite, end pins. Apply the heating tool to the flat part of the pin only. Contact time must be limited to 10 s at up to 300 °C. When using proper tools, all other pins can be soldered in one operation within 2 to 5 s at between 270 and 320 °C. (Pulse-heated soldering is not recommended for SO packages.)

For pulse-heated solder tool (resistance) soldering of VSO packages, solder is applied to the substrate by dipping or by an extra thick tin/lead plating before package placement.

DEFINITIONS

Data sheet status	
Objective specification	This data sheet contains target or goal specifications for product development.
Preliminary specification	This data sheet contains preliminary data; supplementary data may be published later.
Product specification	This data sheet contains final product specifications.
Limiting values	
Limiting values given are in accordance with the Absolute Maximum Rating System (IEC 134). Stress above one or more of the limiting values may cause permanent damage to the device. These are stress ratings only and operation of the device at these or at any other conditions above those given in the Characteristics sections of the specification is not implied. Exposure to limiting values for extended periods may affect device reliability.	
Application information	
Where application information is given, it is advisory and does not form part of the specification.	

LIFE SUPPORT APPLICATIONS

These products are not designed for use in life support appliances, devices, or systems where malfunction of these products can reasonably be expected to result in personal injury. Philips customers using or selling these products for use in such applications do so at their own risk and agree to fully indemnify Philips for any damages resulting from such improper use or sale.

Philips Semiconductors – a worldwide company

Argentina: IEROD, Av. Juramento 1992 - 14.b, (1428)
BUENOS AIRES, Tel. (541)786 7633, Fax. (541)786 9367

Australia: 34 Waterloo Road, NORTH RYDE, NSW 2113,
Tel. (02)805 4455, Fax. (02)805 4466

Austria: Triester Str. 64, A-1101 WIEN, P.O. Box 213,
Tel. (01)60 101-1236, Fax. (01)60 101-1211

Belgium: Postbus 90050, 5600 PB EINDHOVEN, The Netherlands,
Tel. (31)40 783 749, Fax. (31)40 788 399

Brazil: Rua do Rocio 220 - 5th floor, Suite 51,
CEP: 04552-903-SÃO PAULO-SP, Brazil.
P.O. Box 7383 (01064-970).
Tel. (011)821-2333, Fax. (011)829-1849

Canada: PHILIPS SEMICONDUCTORS/COMPONENTS:
Tel. (800) 234-7381, Fax. (708) 296-8556

Chile: Av. Santa Maria 0760, SANTIAGO,
Tel. (02)773 816, Fax. (02)777 6730

Colombia: IPRELENTO LTDA, Carrera 21 No. 56-17,
77621 BOGOTÁ, Tel. (571)249 7624/(571)217 4609,
Fax. (571)217 4549

Denmark: Prags Boulevard 80, PB 1919, DK-2300 COPENHAGEN S,
Tel. (032)88 2636, Fax. (031)57 1949

Finland: Sinikalliontie 3, FIN-02630 ESPOO,
Tel. (9)0-50261, Fax. (9)0-520971

France: 4 Rue du Port-aux-Vins, BP317,
92156 SURESNES Cedex,
Tel. (01)4099 6161, Fax. (01)4099 6427

Germany: P.O. Box 10 63 23, 20043 HAMBURG,
Tel. (040)3296-0, Fax. (040)3296 213.

Greece: No. 15, 25th March Street, GR 17778 TAVROS,
Tel. (01)4894 339/4894 911, Fax. (01)4814 240

Hong Kong: PHILIPS HONG KONG Ltd., 6/F Philips Ind. Bldg.,
24-28 Kung Yip St., KWAI CHUNG, N.T.,
Tel. (852)424 5121, Fax. (852)428 6729

India: Philips INDIA Ltd, Shivsagar Estate, A Block,
Dr. Annie Besant Rd. Worli, Bombay 400 018
Tel. (022)4938 541, Fax. (022)4938 722

Indonesia: Philips House, Jalan H.R. Rasuna Said Kav. 3-4,
P.O. Box 4252, JAKARTA 12950,
Tel. (021)5201 122, Fax. (021)5205 189

Ireland: Newstead, Clonskeagh, DUBLIN 14,
Tel. (01)640 000, Fax. (01)640 200

Italy: PHILIPS SEMICONDUCTORS S.r.l.,
Piazza IV Novembre 3, 20124 MILANO,
Tel. (0039)2 6752 2531, Fax. (0039)2 6752 2557

Japan: Philips Bldg 13-37, Kohnan2-chome, Minato-ku, TOKYO 108,
Tel. (03)3740 5028, Fax. (03)3740 0580

Korea: (Republic of) Philips House, 260-199 Itaewon-dong,
Yongsan-ku, SEOUL, Tel. (02)794-5011, Fax. (02)798-8022

Malaysia: No. 76 Jalan Universiti, 46200 PETALING JAYA,
SELANGOR, Tel. (03)750 5214, Fax. (03)757 4880

Mexico: 5900 Gateway East, Suite 200, EL PASO, TX 79905,
Tel. 9-5(800)234-7381, Fax. (708)296-8556

Netherlands: Postbus 90050, 5600 PB EINDHOVEN, Bldg. VB
Tel. (040)783749, Fax. (040)788399

New Zealand: 2 Wagener Place, C.P.O. Box 1041, AUCKLAND,
Tel. (09)849-4160, Fax. (09)849-7811

Norway: Box 1, Manglerud 0612, OSLO,
Tel. (022)74 8000, Fax. (022)74 8341

Pakistan: Philips Electrical Industries of Pakistan Ltd.,
Exchange Bldg. ST-2/A, Block 9, KDA Scheme 5, Clifton,
KARACHI 75600, Tel. (021)587 4641-49,
Fax. (021)577035/5874546.

Philippines: PHILIPS SEMICONDUCTORS PHILIPPINES Inc,
106 Valero St. Salcedo Village, P.O. Box 2108 MCC, MAKATI,
Metro MANILA, Tel. (02)810 0161, Fax. (02)817 3474

Portugal: PHILIPS PORTUGUESA, S.A.,
Rua dr. António Loureiro Borges 5, Arquiparque - Miraflores,
Apartado 300, 2795 LINDA-A-VELHA,
Tel. (01)4163160/4163333, Fax. (01)4163174/4163366.

Singapore: Lorong 1, Toa Payoh, SINGAPORE 1231,
Tel. (65)350 2000, Fax. (65)251 6500

South Africa: S.A. PHILIPS Pty Ltd.,
195-215 Main Road Martindale, 2092 JOHANNESBURG,
P.O. Box 7430 Johannesburg 2000,
Tel. (011)470-5911, Fax. (011)470-5494.

Spain: Balmes 22, 08007 BARCELONA,
Tel. (03)301 6312, Fax. (03)301 42 43

Sweden: Kottbygatan 7, Akalla. S-164 85 STOCKHOLM,
Tel. (0)8-632 2000, Fax. (0)8-632 2745

Switzerland: Allmendstrasse 140, CH-8027 ZÜRICH,
Tel. (01)488 2211, Fax. (01)481 77 30

Taiwan: PHILIPS TAIWAN Ltd., 23-30F, 66, Chung Hsiao West
Road, Sec. 1. Taipei, Taiwan ROC, P.O. Box 22978,
TAIPEI 100, Tel. (02)388 7666, Fax. (02)382 4382.

Thailand: PHILIPS ELECTRONICS (THAILAND) Ltd.,
209/2 Sanpavuth-Bangna Road Prakanong,
Bangkok 10260, THAILAND,
Tel. (662)398-0141, Fax. (662)398-3319.

Turkey: Talatpasa Cad. No. 5, 80640 GÜLTEPE/ISTANBUL,
Tel. (0212)279 2770, Fax. (0212)269 3094

United Kingdom: Philips Semiconductors LTD.,
276 Bath road, Hayes, MIDDLESEX UB3 5BX,
Tel. (081)73050000, Fax. (081)7548421

United States: 811 East Arques Avenue, SUNNYVALE,
CA 94088-3409, Tel. (800)234-7381, Fax. (708)296-8556

Uruguay: Coronel Mora 433, MONTEVIDEO,
Tel. (02)70-4044, Fax. (02)92 0601

For all other countries apply to: Philips Semiconductors,
International Marketing and Sales, Building BE-p,
P.O. Box 218, 5600 MD, EINDHOVEN, The Netherlands,
Telex 35000 phtncl, Fax. +31-40-724825

SCD35 © Philips Electronics N.V. 1994

All rights are reserved. Reproduction in whole or in part is prohibited without the prior written consent of the copyright owner.

The information presented in this document does not form part of any quotation or contract, is believed to be accurate and reliable and may be changed without notice. No liability will be accepted by the publisher for any consequence of its use. Publication thereof does not convey nor imply any license under patent- or other industrial or intellectual property rights.

Printed in The Netherlands

373061/1500/01/pp20
Document order number:

Date of release: December 1994
9397 743 50011

Philips Semiconductors



PHILIPS