

Ordering Information

PART NUMBER (Note)	PART MARKING	TEMP. RANGE (°C)	PACKAGE (Pb-Free)	PKG. DWG. #
QLX4600LIQT7	QLX4600LIQ	0 to +70	46 Ld QFN 7" Prod. Tape & Reel; Qty 1,000	L46.4x7
QLX4600LIQSR	QLX4600LIQ	0 to +70	46 Ld QFN 7" Sample Reel; Qty 100	L46.4x7

NOTE: These Intersil Pb-free plastic packaged products employ special Pb-free material sets; molding compounds/die attach materials and NiPdAu plate - e4 termination finish, which is RoHS compliant and compatible with both SnPb and Pb-free soldering operations. Intersil Pb-free products are MSL classified at Pb-free peak reflow temperatures that meet or exceed the Pb-free requirements of IPC/JEDEC J STD-020.

Pin Configuration

QLx4600-SL30
(46 LD 4x7 QFN)
TOP VIEW

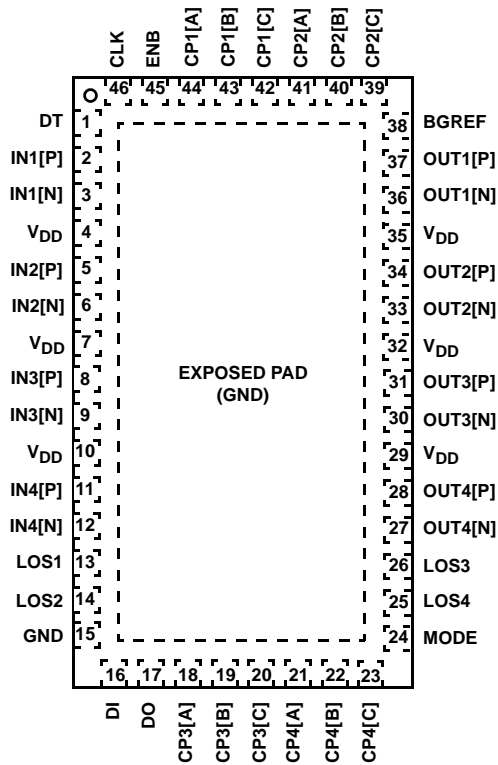

Pin Descriptions

PIN NAME	PIN NUMBER	DESCRIPTION
DT	1	Detection Threshold. Reference DC current threshold for input signal power detection. Data output OUT[k] is muted when the power of the equalized version of IN[k] falls below the threshold. Tie to ground to disable electrical idle preservation and always enable the limiting amplifier.
IN1[P,N]	2, 3	Equalizer 1 differential input, CML. The use of 100nF low ESL/ESR MLCC capacitor with at least 4GHz frequency response is recommended.
V _{DD}	4, 7, 10, 29, 32, 35	Power supply. 1.2V supply voltage. The use of parallel 100pF and 10nF decoupling capacitors to ground is recommended for each of these pins for broad high-frequency noise suppression.
IN2[P,N]	5, 6	Equalizer 2 differential input, CML. The use of 100nF low ESL/ESR MLCC capacitor with at least 4GHz frequency response is recommended.
IN3[P,N]	8, 9	Equalizer 3 differential input, CML. The use of 100nF low ESL/ESR MLCC capacitor with at least 4GHz frequency response is recommended.
IN4[P,N]	11, 12	Equalizer 4 differential input, CML. The use of 100nF low ESL/ESR MLCC capacitor with at least 4GHz frequency response is recommended.
LOS1	13	LOS indicator 1. High output when equalized IN1 signal is below DT threshold.
LOS2	14	LOS indicator 2. High output when equalized IN2 signal is below DT threshold.
GND	15	Ground
DI	16	Serial data input, CMOS logic. Input for serial data stream to program internal registers controlling the boost for all four equalizers. Synchronized with clock (CLK) on pin 46. Overrides the boost setting established on CP control pins. Internally pulled down.
DO	17	Serial data output, CMOS logic. Output of the internal registers controlling the boost for all four equalizers. Synchronized with clock on pin 46. Equivalent to serial data input on DI but delayed by 21 clock cycles.
CP3[A,B,C]	18, 19, 20	Control pins for setting equalizer 3. CMOS logic inputs. Pins are read as a 3-digit number to set the boost level. A is the MSB, and C is the LSB. Pins are internally pulled down through a 25kΩ resistor.
CP4[A,B,C]	21, 22, 23	Control pins for setting equalizer 4. CMOS logic inputs. Pins are read as a 3-digit number to set the boost level. A is the MSB, and C is the LSB. Pins are internally pulled down through a 25kΩ resistor.
MODE	24	Boost-level control mode input, CMOS logic. Allows serial programming of internal registers through pins DI, ENB, and Clk when set HIGH. Resets all internal registers to zero and uses boost levels set by CP pins when set LOW. If serial programming is not used, this pin should be grounded.
LOS4	25	LOS indicator 4. High output when equalized IN4 signal is below DT threshold.
LOS3	26	LOS indicator 3. High output when equalized IN3 signal is below DT threshold.
OUT4[N,P]	27, 28	Equalizer 4 differential output, CML. The use of 100nF low ESL/ESR MLCC capacitor with at least 4GHz frequency response is recommended.
OUT3[N,P]	30, 31	Equalizer 3 differential output, CML. The use of 100nF low ESL/ESR MLCC capacitor with at least 4GHz frequency response is recommended.
OUT2[N,P]	33, 34	Equalizer 2 differential output, CML. The use of 100nF low ESL/ESR MLCC capacitor with at least 4GHz frequency response is recommended.
OUT1[N,P]	36, 37	Equalizer 1 differential output, CML. The use of 100nF low ESL/ESR MLCC capacitor with at least 4GHz frequency response is recommended.
BGREF	38	External bandgap reference resistor. Recommended value of 6.04kΩ ±1%.

Pin Descriptions

PIN NAME	PIN NUMBER	DESCRIPTION
CP2[C,B,A]	39, 40, 41	Control pins for setting equalizer 2. CMOS logic inputs. Pins are read as a 3-digit number to set the boost level. A is the MSB, and C is the LSB. Pins are internally pulled down through a 25k Ω resistor.
CP1[C,B,A]	42, 43, 44	Control pins for setting equalizer 1. CMOS logic inputs. Pins are read as a 3-digit number to set the boost level. A is the MSB, and C is the LSB. Pins are internally pulled down through a 25k Ω resistor.
ENB	45	Serial data enable (active low), CMOS logic. Internal registers can be programmed with DI and CLK pins only when the ENB pin is 'LOW'. Internally pulled down.
CLK	46	Serial data clock, CMOS logic. Synchronous clock for serial data on DI and DO pins. Data on DI is latched on the rising clock edge. Clock speed is recommended to be between 10MHz and 20MHz. Internally pulled down.
EXPOSED PAD	-	Exposed ground pad. For proper electrical and thermal performance, this pad should be connected to the PCB ground plane.

QLx4600-SL30

Absolute Maximum Ratings

Supply Voltage (V_{DD} to GND) -0.3V to 1.3V
 Voltage at All Input Pins -0.3V to $V_{DD} + 0.3V$
 ESD Rating at All Pins 2kV (HBM)

Thermal Information

Thermal Resistance (Typical) θ_{JA} ($^{\circ}C/W$) θ_{JC} ($^{\circ}C/W$)
 46 Ld QFN Package (Note 1) 32 2.3
 Operating Ambient Temperature Range $0^{\circ}C$ to $+70^{\circ}C$
 Storage Ambient Temperature Range $-55^{\circ}C$ to $+150^{\circ}C$
 Maximum Junction Temperature $+125^{\circ}C$
 Pb-Free Reflow Profile see link below
<http://www.intersil.com/pbfree/Pb-FreeReflow.asp>

CAUTION: Do not operate at or near the maximum ratings listed for extended periods of time. Exposure to such conditions may adversely impact product reliability and result in failures not covered by warranty.

NOTE:

- θ_{JA} is measured with the component mounted on a high effective thermal conductivity test board in free air. See Tech Brief TB379 for details.

Operating Conditions

PARAMETER	SYMBOL	CONDITION	MIN	TYP	MAX	UNITS
Supply Voltage	V_{DD}		1.1	1.2	1.3	V
Operating Ambient Temperature	T_A		0	25	70	$^{\circ}C$
Bit Rate		NRZ data applied to any channel	1.5		6.25	Gb/s

Control Pin Characteristics Typical values are at $V_{DD} = 1.2V$, $T_A = +25^{\circ}C$, and $V_{IN} = 800mV_{p-p}$, unless otherwise noted. $V_{DD} = 1.1V$ to $1.3V$, $T_A = 0^{\circ}C$ to $+70^{\circ}C$.

PARAMETER	SYMBOL	CONDITION	MIN	TYP	MAX	UNITS	NOTES
Input 'LOW' Logic Level	V_{IL}	DI, CIK, ENB	0	0	350	mV	
Input 'HIGH' Logic Level	V_{IH}	DI, CIK, ENB	750		V_{DD}	mV	
Output 'LOW' Logic Level	V_{OL}	LOS[k], DO	0	0	250	mV	
Output 'HIGH' Logic Level	V_{OH}	LOS[k], DO	1000		V_{DD}	mV	
'LOW' Resistance State		CP[k][A,B,C]	0		1	k Ω	2
'MID' Resistance State		CP[k][B,C]	22.5	25	27.5	k Ω	2
'HIGH' Resistance State		CP[k][A,B,C]	500		∞	k Ω	2
Input Current		Current draw on digital pin, i.e., CP[k][A,B,C], DI, CIK, ENB		30	100	μA	

NOTE:

- If four CP pins are tied together, the resistance values in this table should be divided by four.

Electrical Specifications Typical values are at $V_{DD} = 1.2V$, $T_A = +25^{\circ}C$, and $V_{IN} = 800mV_{p-p}$, unless otherwise noted. $V_{DD} = 1.1V$ to $1.3V$, $T_A = 0^{\circ}C$ to $+70^{\circ}C$.

PARAMETERS	SYMBOL	CONDITION	MIN	TYP	MAX	UNITS	NOTES
Supply Current	I_{DD}			260		mA	
Cable Input Amplitude Range	V_{IN}	Measured differentially at data source before encountering channel loss	800	1200	1600	mV_{p-p}	3
DC Differential Input Resistance		Measured on input channel IN[k]	80	100	120	Ω	
DC Single-Ended Input Resistance		Measured on input channel IN[k]P or IN[k]N	40	50	60	Ω	
Input Return Loss (Differential)	S_{DD11}	50MHz to 3.75GHz	10			dB	4

QLx4600-SL30

Electrical Specifications Typical values are at $V_{DD} = 1.2V$, $T_A = +25^\circ C$, and $V_{IN} = 800mV_{p-p}$, unless otherwise noted.
 $V_{DD} = 1.1V$ to $1.3V$, $T_A = 0^\circ C$ to $+70^\circ C$. **(Continued)**

PARAMETERS	SYMBOL	CONDITION	MIN	TYP	MAX	UNITS	NOTES
Input Return Loss (Common Mode)	S_{CC11}	50MHz to 3.75GHz	6			dB	4
Input Return Loss (Com. to Diff. Conversion)	S_{DC11}	50MHz to 3.75GHz	20			dB	4
Output Amplitude Range	V_{OUT}	Active data transmission mode; Measured differentially at OUT[k]P and OUT[k]N with 50Ω load on both output pins	450	550	650	mV _{p-p}	
		Line Silence mode; Measured differentially at OUT[k]P and OUT[k]N with 50Ω load on both output pins		10	20	mV _{p-p}	
Differential Output Impedance		Measured on OUT[k]	80	105	120	Ω	
Output Return Loss (Differential)	S_{DD22}	50MHz to 3.75GHz	10			dB	4
Output Return Loss (Common Mode)	S_{CC22}	50MHz to 3.75GHz	5			dB	4
Output Return Loss (Com. to Diff. Conversion)	S_{DC22}	50MHz to 3.75GHz	20			dB	4
Output Residual Jitter		2.5Gb/s, 3.125Gb/s, 4.25Gb/s, 5Gb/s; Up to 20m 24AWG standard twin-axial cable (approx. -25dB @ 2.5GHz); 800mV _{p-p} ≤ VIN ≤ 1600mV _{p-p}		0.15	0.25	UI	3, 5, 6
		2.5Gb/s, 3.125Gb/s, 4.25Gb/s, 5Gb/s; 12m 30AWG standard twin-axial cable (approx. -30dB @ 2.5GHz); 800mV _{p-p} ≤ VIN ≤ 1600mV _{p-p}		0.20	0.30	UI	3, 5, 6
		2.5Gb/s, 3.125Gb/s, 4.25Gb/s, 5Gb/s; 20m 28AWG standard twin-axial cable (approx. -35dB @ 2.5GHz); 1200mV _{p-p} ≤ VIN ≤ 1600mV _{p-p}		0.25	0.35	UI	3, 5, 6
		6.25Gb/s, Up to 15m 28AWG standard twin-axial cable (approx. -30dB @ 3.2GHz); 1200mV _{p-p} ≤ VIN ≤ 1600mV _{p-p}		0.25	0.35	UI	3, 5, 6
Output Transition Time	t_r, t_f	20% to 80%	30	60	80	ps	7
Lane-to-Lane Skew					50	ps	
Propagation Delay		From IN[k] to OUT[k]			500	ps	
LOS Assert Time		Time to assert Loss-of-Signal (LOS) indicator when transitioning from active data mode to line silence mode			100	μs	8
LOS De-Assert Time		Time to assert Loss-of-Signal (LOS) indicator when transitioning from line silence mode to active data mode			100	μs	8
Data-to-Line Silence Response Time	t_{DS}	Time to transition from active data to line silence (muted output) on 20m 24AWG standard twin-axial cable at 5Gb/s			15	ns	8, 11
		Time from last bit of ALIGN(0) for SAS OOB signaling to line silence (<20mV _{p-p} output); Meritec 24AWG 20m; 3Gb/s			14	ns	12

QLx4600-SL30

Electrical Specifications Typical values are at $V_{DD} = 1.2V$, $T_A = +25^{\circ}C$, and $V_{IN} = 800mV_{p-p}$, unless otherwise noted. $V_{DD} = 1.1V$ to $1.3V$, $T_A = 0^{\circ}C$ to $+70^{\circ}C$. **(Continued)**

PARAMETERS	SYMBOL	CONDITION	MIN	TYP	MAX	UNITS	NOTES
Line Silence-to-Data Response Time	t_{SD}	Time to transition from line silence mode (muted output) to active data on 20m 24AWG standard twin-axial cable at 5Gb/s			20	ns	8, 11
		Time from first bit of ALIGN(0) for SAS OOB signaling to 450mV _{p-p} output; Meritec 24AWG 20m; 3Gb/s			19	ns	12
Timing Difference (SAS)	$ t_{DS} - t_{SD} $	For SAS OOB signaling support; Meritec 24AWG 20m			5	ns	12

NOTES:

3. After channel loss, differential amplitudes at QLx4600-SL30 inputs must meet the input voltage range specified in "Absolute Maximum Ratings" on page 5.
4. Temperature = $+25^{\circ}C$, $V_{DD} = 1.2V$.
5. Output residual jitter is the difference between the total jitter at the lane extender output and the total jitter of the transmitted signal (as measured at the input to the channel). Total jitter (TJ) is $DJ_{pp} + 14.1 \times RJ_{RMS}$.
6. Measured using a PRBS 2⁷-1 pattern. Deterministic jitter at the input to the lane extender is due to frequency-dependent, media-induced loss only.
7. Rise and fall times measured using a 1GHz clock with a 20ps edge rate.
8. For active data mode, cable input amplitude is 400mV_{p-p} (differential) or greater. For line silence mode, cable input amplitude is 20mV_{p-p} (differential) or less.
9. Measured differentially across the data source.
10. During line silence, transmitter noise in excess of this voltage range may result in differential output amplitudes from the QLx4600 that are greater than 20mV_{p-p}.
11. The data pattern preceding line silence mode is comprised of the PCIe electrical idle ordered set (EIOS). The data pattern following line silence mode is comprised of the PCIe electrical idle exit sequence (EIES).
12. The data pattern preceding or following line silence mode is comprised of the SAS-2 ALIGN (0) sequence for OOB signaling at 3Gb/s, and amplitude of 800mV_{p-p}.

Serial Bus Timing Characteristics

PARAMETER	SYMBOL	CONDITION	MIN	TYP	MAX	UNITS
CLK Setup Time	t_{SCK}	From the falling edge of ENB	10			ns
DI Setup Time	t_{SDI}	Prior to the rising edge of CLK	10			ns
DI Hold Time	t_{HDI}	From the rising edge of CLK	6			ns
ENB 'HIGH'	t_{HEN}	From the falling edge of the last data bit's CLK	10			ns
Boost Setting Operational	t_D	From ENB 'HIGH'			10	ns
DO Hold Time	t_{CQ}	From the rising edge of CLK to DO transition	12			ns
Clock Rate	f_{CLK}	Reference clock for serial bus EQ programming			20	MHz

Typical Performance Characteristics

$V_{DD} = 1.2V$, $T_A = +25^{\circ}C$, unless otherwise noted. Performance was characterized using the system testbed shown in Figure 1. Unless otherwise noted, the transmitter generated a non-return-to-zero (NRZ) PRBS-7 sequence at $800mV_{p,p}$ (differential) with 10ps of peak-to-peak deterministic jitter. This transmit signal was launched into twin-axial cable test channels of varying gauges and lengths. The loss characteristics of these test channels are plotted as a function of frequency in Figure 2. The received signal at the output of these test channels was then processed by the QLx4600-SL30 before being passed to a receiver. Eye diagram measurements were made with 4000 waveform acquisitions and include random jitter.

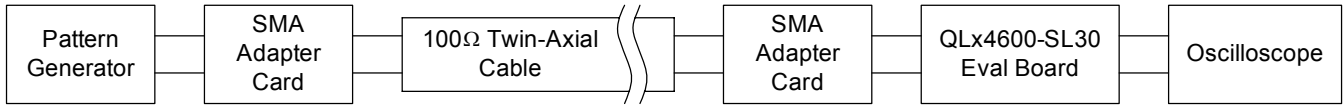

FIGURE 1. DEVICE CHARACTERIZATION TEST SETUP

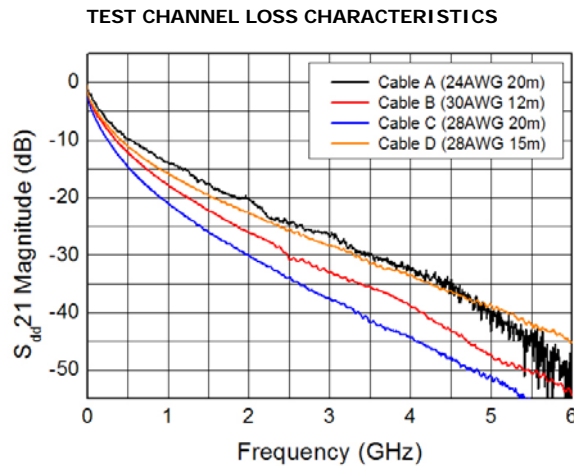

FIGURE 2. TWIN-AXIAL CABLE LOSS AS A FUNCTION OF FREQUENCY FOR VARIOUS TEST CHANNELS

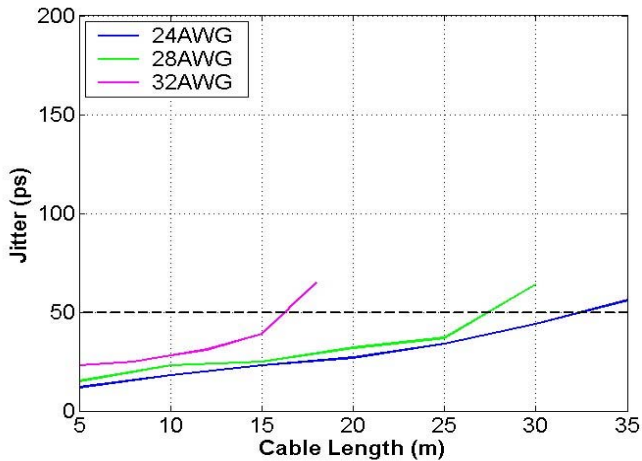

FIGURE 3A. JITTER vs CABLE LENGTH, 5Gb/s

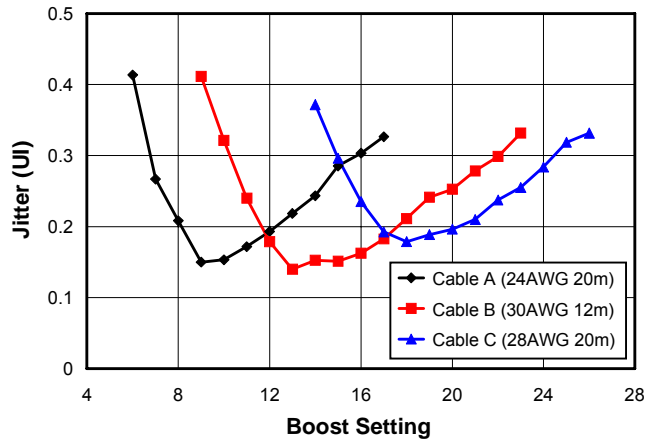

FIGURE 3B. JITTER vs BOOST SETTING, 5Gb/s

FIGURE 3. JITTER VS CABLE LENGTH AND JITTER VS BOOST SETTING AT 5 GBPS

Typical Performance Characteristics (Continued)

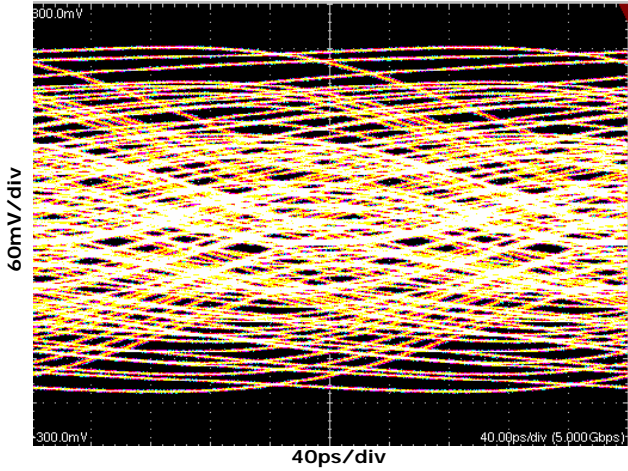

FIGURE 4. RECEIVED SIGNAL AFTER 20m OF 24AWG TWIN-AXIAL CABLE (CABLE A), 5Gb/s

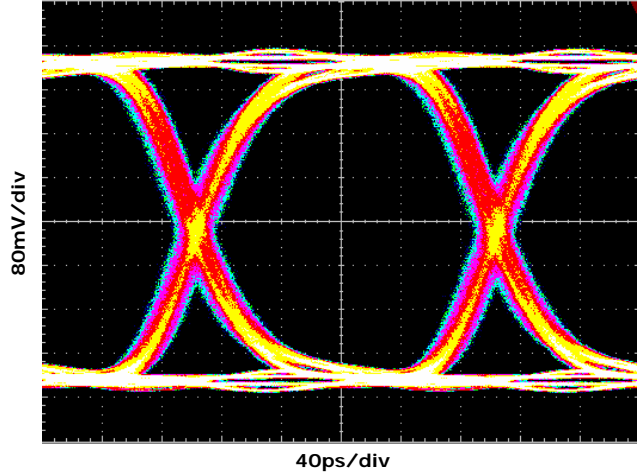

FIGURE 5. QLx4600-SL30 OUTPUT AFTER 20m OF 24AWG TWIN-AXIAL CABLE (CABLE A), 5Gb/s

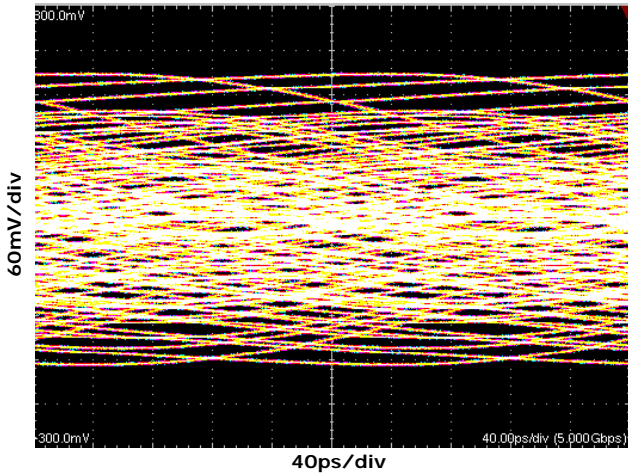

FIGURE 6. RECEIVED SIGNAL AFTER 12m OF 30AWG TWIN-AXIAL CABLE (CABLE B), 5Gb/s

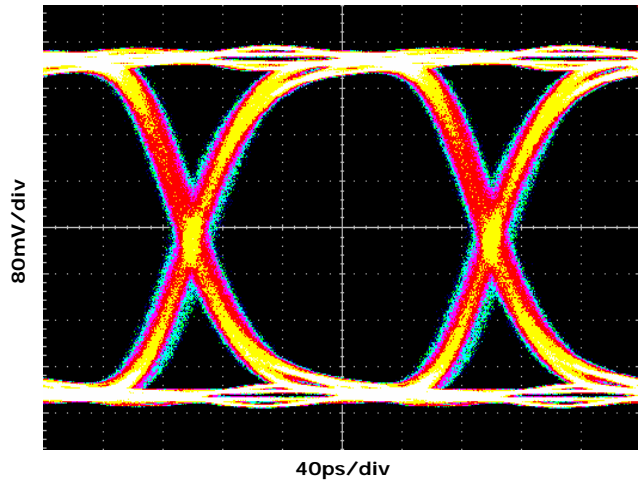

FIGURE 7. QLx4600-SL30 OUTPUT AFTER 12m OF 30AWG TWIN-AXIAL CABLE (CABLE B), 5Gb/s

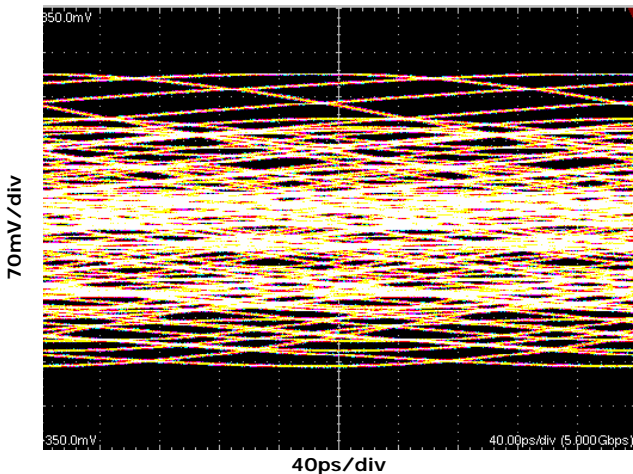

FIGURE 8. RECEIVED SIGNAL AFTER 20m OF 28AWG TWIN-AXIAL CABLE (CABLE C) (NOTE 13), 5Gb/s

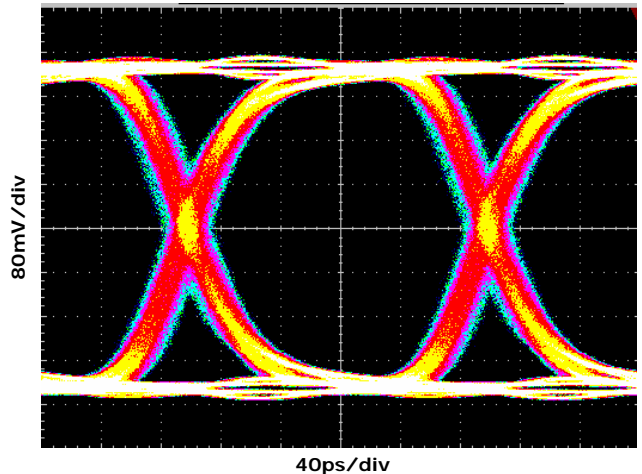

FIGURE 9. QLx4600-S30 OUTPUT AFTER 20m OF 28AWG TWIN-AXIAL CABLE (CABLE C) (NOTE 13), 5Gb/s

Typical Performance Characteristics (Continued)

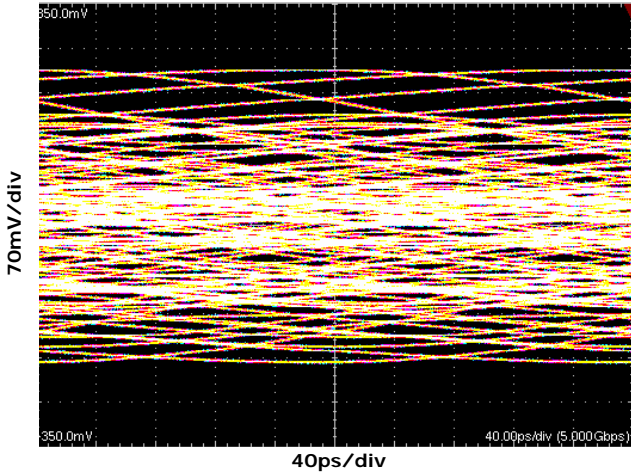

FIGURE 10. RECEIVED SIGNAL AFTER 30m OF 24AWG TWIN-AXIAL CABLE (NOTE 13), 5Gb/s

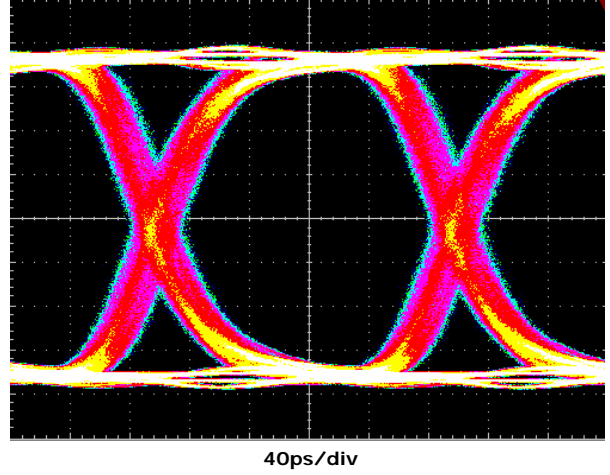

FIGURE 11. QLx4600-SL30 OUTPUT AFTER 30m OF 24AWG TWIN-AXIAL CABLE (NOTE 13), 5Gb/s

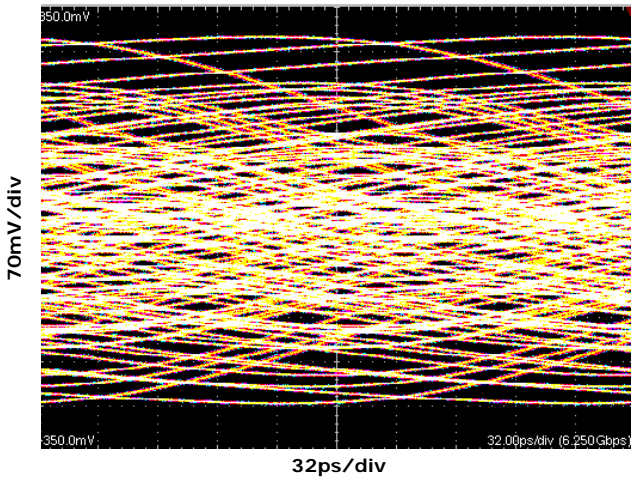

FIGURE 12. RECEIVED SIGNAL AFTER 15m OF 28AWG TWIN-AXIAL CABLE (CABLE D) (NOTE 13), 6.25Gb/s

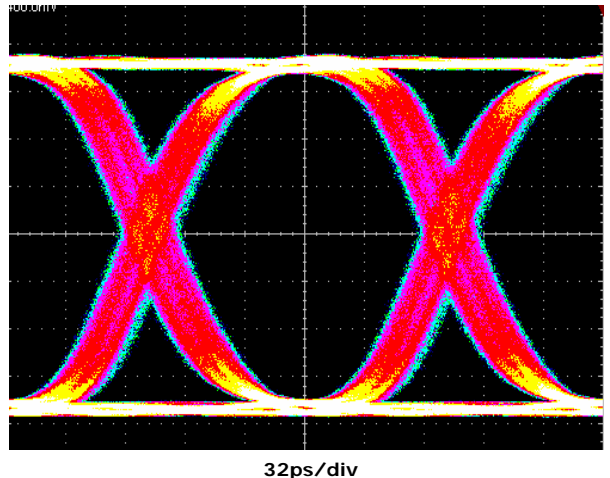

FIGURE 13. QLx4600-SL30 OUTPUT AFTER 15m OF 28AWG TWIN-AXIAL CABLE (CABLE D) (NOTE 13), 6.25Gb/s

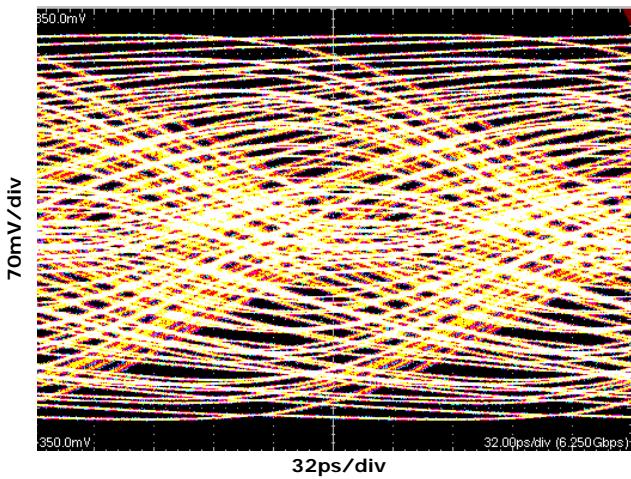

FIGURE 14. RECEIVED SIGNAL AFTER 40" FR4, 6.25Gb/s

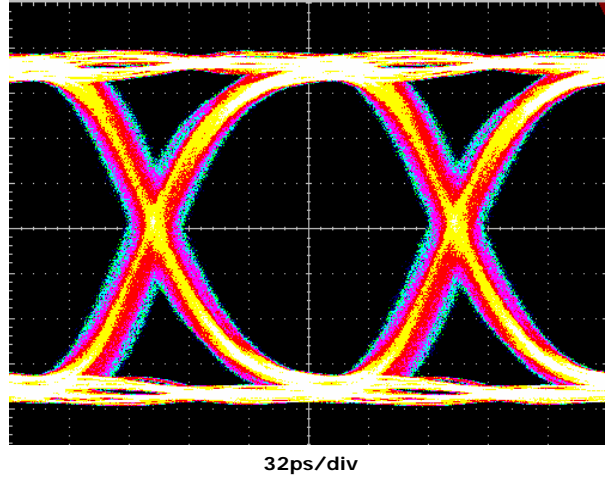

FIGURE 15. QLx4600-SL30 OUTPUT AFTER 40" FR4, 6.25Gb/s

Typical Performance Characteristics (Continued)

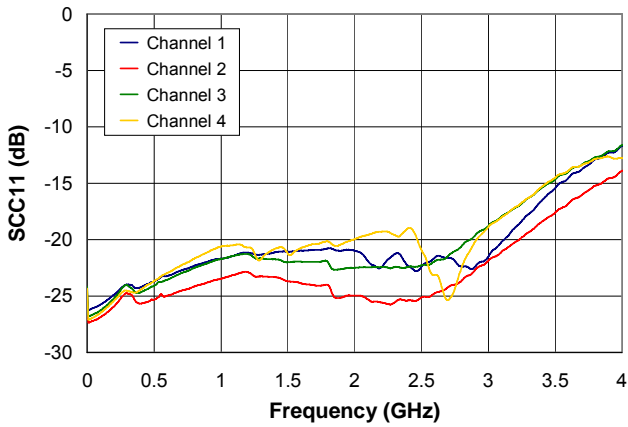

FIGURE 16. INPUT COMMON-MODE RETURN LOSS

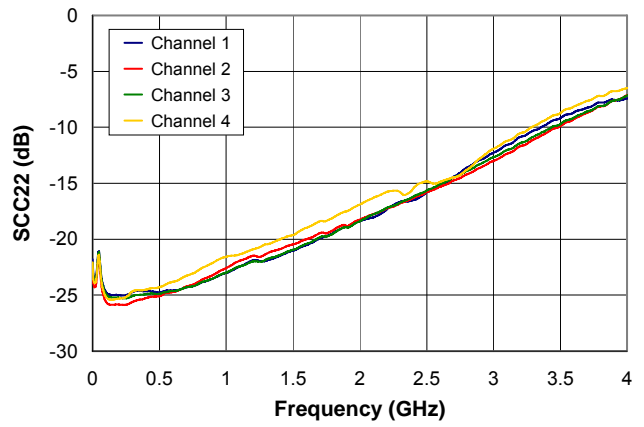

FIGURE 17. OUTPUT COMMON-MODE RETURN LOSS

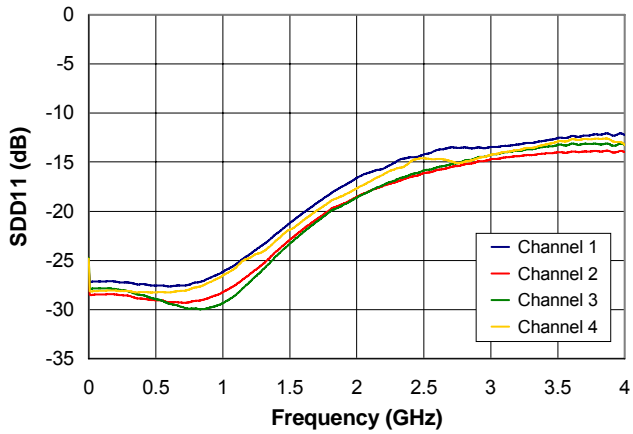

FIGURE 18. INPUT DIFFERENTIAL RETURN LOSS

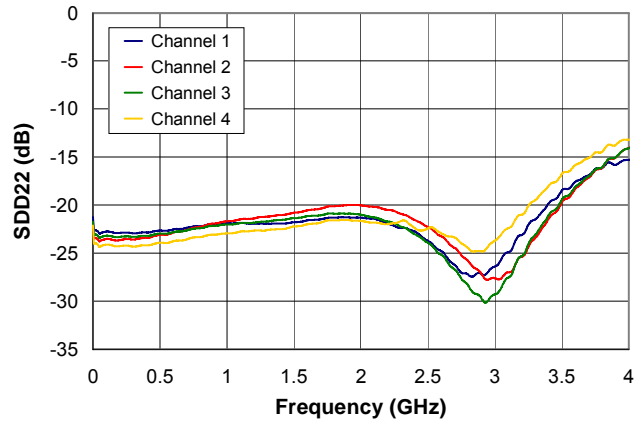

FIGURE 19. OUTPUT DIFFERENTIAL RETURN LOSS

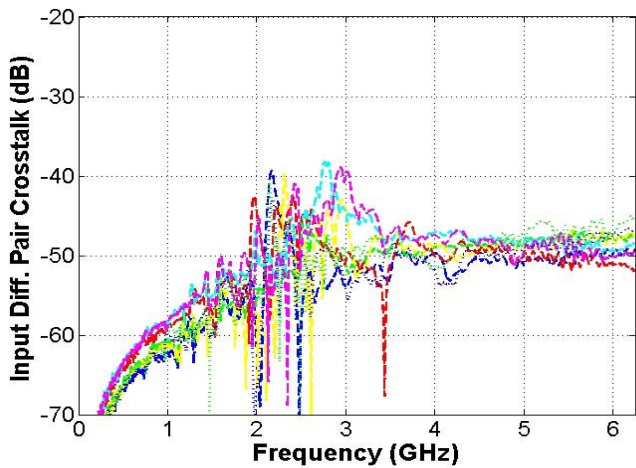

FIGURE 20. DIFFERENTIAL CROSSTALK BETWEEN ADJACENT INPUT CHANNELS

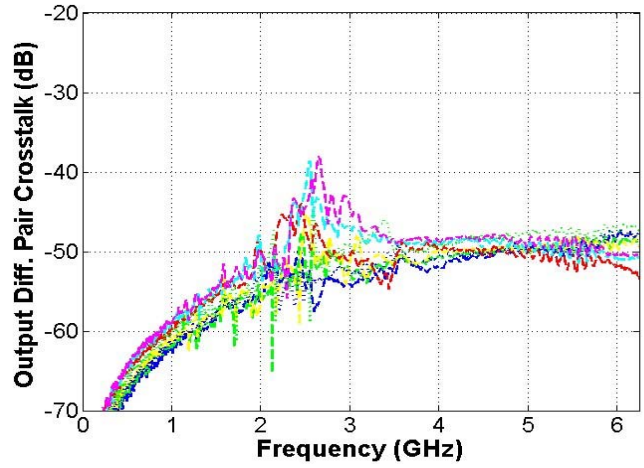

FIGURE 21. DIFFERENTIAL CROSSTALK BETWEEN ADJACENT OUTPUT CHANNELS

NOTE:

13. Differential transmit amplitude = 1200mV_{p-p}.

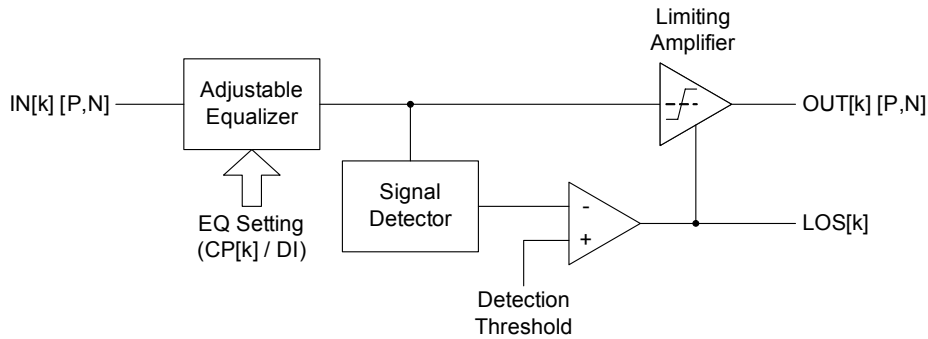

FIGURE 22. FUNCTIONAL DIAGRAM OF A SINGLE CHANNEL WITHIN THE QLx4600-SL30

Operation

The QLx4600-SL30 is an advanced quad lane-extender for high-speed interconnects. A functional diagram of one of the four channels in the QLx4600-SL30 is shown in Figure 22. In addition to a robust equalization filter to compensate for channel loss and restore signal fidelity, the QLx4600-SL30 contains unique integrated features to preserve special signaling protocols typically broken by other equalizers. The signal detect function is used to mute the channel output when the equalized signal falls below the level determined by the Detection Threshold (DT) pin voltage. This function is intended to preserve periods of line silence (“quiescent state” in InfiniBand contexts). Furthermore, the output of the signal detect/DT comparator is used as a loss of signal (LOS) indicator to indicate the absence of a received signal.

As illustrated in Figure 22, the core of each high-speed signal path in the QLx4600-SL30 is a sophisticated equalizer followed by a limiting amplifier. The equalizer compensates for skin loss, dielectric loss, and impedance discontinuities in the transmission channel. Each equalizer is followed by a limiting amplification stage that provides a clean output signal with full amplitude swing and fast rise-fall times for reliable signal decoding in a subsequent receiver.

Individually Adjustable Equalization Boost

Each channel in the QLx4600-SL30 features an independently settable equalizer for custom signal restoration. Each equalizer can be set to one of 32 levels of compensation when the serial bus is used to program the boost level and one of 18 compensation levels when the CP[k] pins are used to set the level. The equalizer transfer functions for a subset of these compensation levels are plotted in Figure 23. The flexibility of this adjustable compensation architecture enables signal fidelity to be optimized on a channel-by-channel basis, providing support for a wide variety of channel characteristics and data rates ranging from 2.5Gb/s to 6.25Gb/s. Because the boost level is externally set rather than internally adapted, the QLx4600-SL30 provides reliable communication from the very first bit transmitted. There is no time needed for adaptation and control loop convergence. Furthermore, there are no

pathological data patterns that will cause the QLx4600-SL30 to move to an incorrect boost level.

The Applications Information section beginning on page 13 details how to set the boost level by both the CP-pin voltage approach and the serial programming approach.

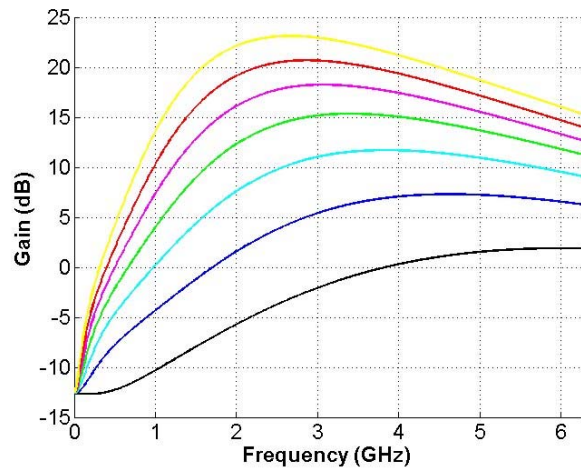

FIGURE 23. EQUALIZER TRANSFER FUNCTIONS FOR SETTINGS 0, 5, 10, 15, 20, 25, AND 31 IN THE QLx4600-SL30

CML Input and Output Buffers

The input and output buffers for the high-speed data channels in the QLx4600-SL30 are implemented using CML. Equivalent input and output circuits are shown in Figures 24 and 25, respectively.

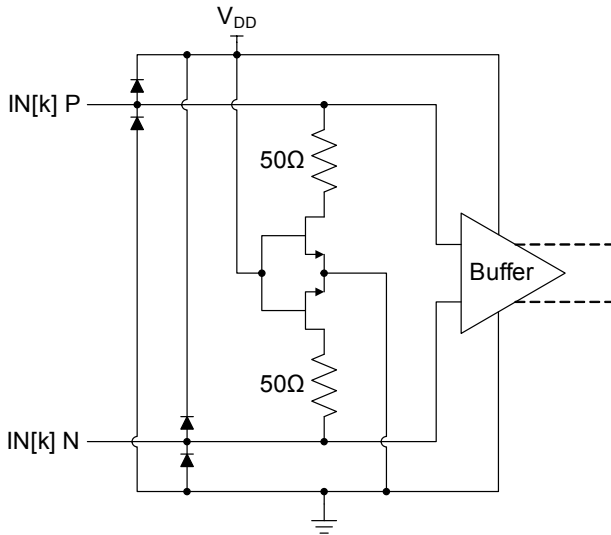

FIGURE 24. CML INPUT EQUIVALENT CIRCUIT FOR THE QLx4600-S30

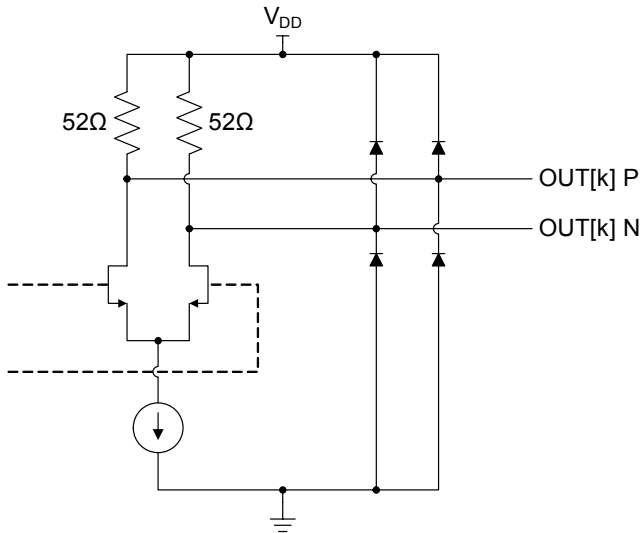

FIGURE 25. CML OUTPUT EQUIVALENT CIRCUIT FOR THE QLx4600-S30

NOTE: The load value of 52Ω is used to internally match SDD₂₂ for a characteristic impedance of 50Ω.

Line Silence/Electrical Idle/Quiescent Mode

Line silence is commonly broken by the limiting amplification in other equalizers. This disruption can be detrimental in many systems that rely on line silence as part of the protocol. The QLx4600-SL30 contains special lane management capabilities to detect and preserve periods of line silence while still providing the fidelity-enhancing benefits of limiting amplification during active data transmission. Line silence is detected by measuring the amplitude of the equalized signal and comparing that to a threshold set by the current at the DT pin. When the amplitude falls below the threshold, the output driver

stages are muted and held at their nominal common mode voltage¹.

LOS Indicator

Pins LOS[k] are used to output the state of the muting circuitry to serve as a loss of signal indicator for channel k. This signal is directly derived from the muting signal off the DT-threshold signal detector output. The LOS signal goes 'HIGH' when the power signal is below the DT threshold and 'LOW' when the power goes above the DT threshold. This feature is meant to be used in optical systems (e.g. QSFP) where there are no quiescent or electrical-idle states. In these cases, the DT threshold is used to determine the sensitivity of the LOS indicator.

Applications Information

Several aspects of the QLx4600-SL30 are capable of being dynamically managed by a system controller to provide maximum flexibility and optimum performance. These functions are controlled by interfacing to the highlighted pins in Figure 26. The specific procedures for controlling these aspects of the QLx4600-SL30 are the focus of this section.

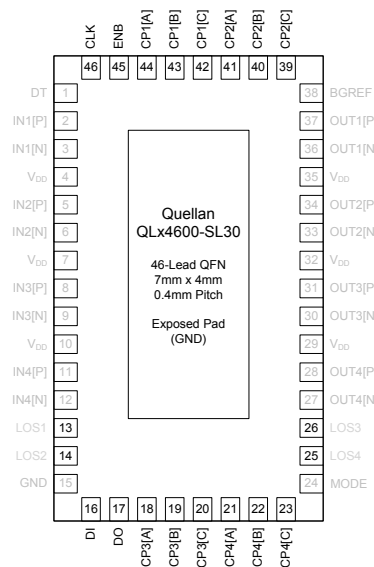

FIGURE 26. PIN DIAGRAM HIGHLIGHTING PINS USED FOR DYNAMIC CONTROL OF THE QLx4600-SL30

Equalization Boost Level

Channel equalization for the QLx4600-SL30 can be individually set to either (a) one of 18 levels through the DC voltages on external control pins or (b) one of 32 levels via a set of registers programmed by a low speed serial bus. The pins used to control the boost level are highlighted in Figure 26. Descriptions of these pins are listed in Table 1. Please refer to "Pin Descriptions" on page 3 for descriptions of all other pins on the QLx4600-SL30.

1. The output common mode voltage remains constant during both active data transmission and output muting modes.

TABLE 1. DESCRIPTIONS OF PINS USED TO SET EQUALIZATION BOOST LEVEL

PIN NAME	PIN NUMBER	DESCRIPTION
DI	16	Serial data input, CMOS logic. Input for serial data stream to program internal registers controlling the boost for all four equalizers. Synchronized with clock (CLK) on pin 46. Overrides the boost setting established on CP control pins. Internally pulled down.
DO	17	Serial data output, CMOS logic. Output of the internal registers controlling the boost for all four equalizers. Synchronized with clock on pin 46. Equivalent to serial data input on DI but delayed by 21 clock cycles.
CP3[A,B,C]	18, 19, 20	Control pins for setting equalizer 3. CMOS logic inputs. Pins are read as a 3-digit number to set the boost level. A is the MSB, and C is the LSB. Pins are internally pulled down through a 25kΩ resistor.
CP4[A,B,C]	21, 22, 23	Control pins for setting equalizer 4. CMOS logic inputs. Pins are read as a 3-digit number to set the boost level. A is the MSB, and C is the LSB. Pins are internally pulled down through a 25kΩ resistor.
MODE	24	Boost-level control mode input, CMOS logic. Allows serial programming of internal registers through pins DI, ENB, and Clk when set HIGH. Resets all internal registers to zero and uses boost levels set by CP pins when set LOW. If serial programming is not used, this pin should be grounded.
CP2[C,B,A]	39, 40, 41	Control pins for setting equalizer 2. CMOS logic inputs. Pins are read as a 3-digit number to set the boost level. A is the MSB, and C is the LSB. Pins are internally pulled down through a 25kΩ resistor.
CP1[C,B,A]	42, 43, 44	Control pins for setting equalizer 1. CMOS logic inputs. Pins are read as a 3-digit number to set the boost level. A is the MSB, and C is the LSB. Pins are internally pulled down through a 25kΩ resistor.
ENB	45	Serial data enable (active low), CMOS logic. Internal registers can be programmed with DI and CLK pins only when the ENB pin is 'LOW'. Internally pulled down.
CLK	46	Serial data clock, CMOS logic. Synchronous clock for serial data on DI and DO pins. Data on DI is latched on the rising clock edge. Clock speed is recommended to be between 10MHz and 20MHz. Internally pulled down.

The boost setting for equalizer channel k can be read as a three digit ternary number across CP[k][A,B,C]. The ternary value is established by the value of the resistor between VDD and the CP[k][A,B,C] pin.

As a second option, the equalizer boost setting can be taken from a set of registers programmed through a serial bus interface (pins 16, 17, 45, and 46). Using this interface, a set of registers is programmed to store the boost level. A total of 21 registers are used. Registers 2 through 21 are parsed into four 5-bit words. Each 5-bit word determines which of 32 boost levels to use for the corresponding equalizer. Register 1 instructs the QLx4600-SL30 to use registers 2 through 21 to set the boost level rather than the control pins CP[k][A,B,C].

Both options have their relative advantages. The control pin option minimizes the need for external controllers as the boost level can be set in the board design resulting in a compact layout. The register option is more flexible for cases in which the optimum boost level will not be known and can be changed by a host bus adapter with a small number of pins. It is noted that the serial bus interface can also be daisy-chained among multiple QLx4600-SL30 devices to afford a compact programmable solution even when a large number of data lines need to be equalized.

Upon power-up, the default value of all the registers (and register 1 in particular) is zero, and thus, the CP pins are used to set the boost level. This permits an alternate interpretation on setting the boost level. Specifically, the

CP pins define the default boost level until the registers are (if ever) programmed via the serial bus.

TABLE 2. MAPPING BETWEEN CP-SETTING RESISTOR AND PROGRAMMED BOOST LEVELS

RESISTANCE BETWEEN CP PIN AND V _{DD}			SERIAL BOOST LEVEL
CP[A]	CP[B]	CP[C]	
Open	Open	Open	0
Open	Open	25kΩ	2
Open	Open	0Ω	4
Open	25kΩ	Open	6
Open	25kΩ	25kΩ	8
Open	25kΩ	0Ω	10
Open	0Ω	Open	12
Open	0Ω	25kΩ	14
Open	0Ω	0Ω	15
0Ω	Open	Open	16
0Ω	Open	25kΩ	17
0Ω	Open	0Ω	19
0Ω	25kΩ	Open	21
0Ω	25kΩ	25kΩ	23
0Ω	25kΩ	0Ω	24
0Ω	0Ω	Open	26
0Ω	0Ω	25kΩ	28
0Ω	0Ω	0Ω	31

Control Pin Boost Setting

When register 1 of the QLx4600-SL30 is zero (the default state on power-up), the voltages at the CP pins are used to determine the boost level of each channel. For each of the four channels, k, the [A], [B], and [C] control pins (CP[k]) are associated with a 3-bit non binary word. While [A] can take one of two values, 'LOW' or 'HIGH', [B] and [C] can take one of three different values: 'LOW', 'MIDDLE', or 'HIGH'. This is achieved by changing the value of a resistor connected between VDD and the CP pin, which is internally pulled low with a 25kΩ resistor. Thus, a 'HIGH' state is achieved by using a 0Ω resistor, 'MIDDLE' is achieved with a 25kΩ resistor, and 'LOW' is achieved with an open resistance. Table 2 defines the mapping from the 3-bit CP word to the 18 out of 32 possible levels available via the serial interface.

If all four channels are to use the same boost level, then a minimum number of board resistors can be realized by tying together like CP[k][A,B,C] pins across all channels k. For instance, all four CP[k][A] pins can be tied to the same resistor running to VDD. Consequently, only three resistors are needed to control the boost of all four channels. If the CP Pins are tied together and the 25kΩ is used, the value changes to a 6.25kΩ resistor because the 25kΩ is divided by 4.

Optimal Cable Boost Settings

The settable equalizing filter within the QLx4600 enables the device to optimally compensate for frequency-dependent attenuation across a wide variety of channels, data rates, and encoding schemes. For the reference channels plotted in Figure 2, Table 3 shows the optimal boost setting when transmitting a PRBS-7 signal. The optimal boost setting is defined as the equalizing filter setting that minimizes the output residual jitter of the QLx4600. The settings in Table 3 represent the optimal settings for the QLx4600C across an ambient temperature range of 0°C to +70°C. The optimal setting at room temperature (+20°C to +40°C) is generally one to two settings lower than the values listed in Table 3.

TABLE 3. OPTIMAL CABLE BOOST SETTINGS

CABLE	APPROX. LOSS @ 2.5GHZ (DB)	QLx4600-SL30 BOOST
Cable A	22	10
Cable B	27	14
Cable C	35	19

NOTE: Optimal boost settings should be determined on an application-by-application basis to account for variations in channel type, loss characteristics, and encoding schemes. The settings in this table are presented as guidelines to be used as a starting point for application-specific optimization.

Register Description

The QLx4600-SL30's internal registers are listed in Table 4. Register 1 determines whether the CP pins or register values 2 through 21 are used to set the boost level. When this register is set, the QLx4600-SL30 uses registers 2-6, 7-11, 12-16, and 17-21 to set the boost level of equalizers 1, 2, 3, and 4. When register 1 is not set, the CP pins are used to determine the boost level for each equalizer channel. The use of five registers for each equalizer channel allows all 32 boost levels as candidate boost levels.

TABLE 4. DESCRIPTION OF INTERNAL SERIAL REGISTERS

REGISTER	EQUALIZER CHANNEL	DESCRIPTION
1	1-4	CP control override – Use registers 2 through 21 (rather than CP pins) to establish the boost levels when this bit is set.
2	1	Equalizer setting bit 0 (LSB).
3		Equalizer setting bit 1.
4		Equalizer setting bit 2.
5		Equalizer setting bit 3.
6		Equalizer setting bit 4 (MSB).
7	2	Equalizer setting bit 0 (LSB).
8		Equalizer setting bit 1.
9		Equalizer setting bit 2.
10		Equalizer setting bit 3.
11		Equalizer setting bit 4 (MSB).
12	3	Equalizer setting bit 0 (LSB).
13		Equalizer setting bit 1.
14		Equalizer setting bit 2.
15		Equalizer setting bit 3.
16		Equalizer setting bit 4 (MSB).
17	4	Equalizer setting bit 0 (LSB).
18		Equalizer setting bit 1.
19		Equalizer setting bit 2.
20		Equalizer setting bit 3.
21		Equalizer setting bit 4 (MSB).

Serial Bus Programming

Pins 16 (DI), 45 (ENB), and 46 (CLK) are used to program the registers inside the QLx4600-SL30. Figure 27 shows an exemplary timing diagram for the signals on these pins. The serial bus can be used to program a single QLx4600-SL30 according to the following steps:

1. The ENB pin is pulled 'LOW'.
 - While this pin is 'LOW', the data input on DI are read into registers but not yet latched.
 - A setup time of t_{SCK} is needed between ENB going 'LOW' and the first rising clock edge.
2. At least 21 values are read from DI on the rising edge of the CLK signal.
 - If more than 21 values are passed in, then only the last 21 values are kept in a FIFO fashion.
 - The data on DI should start by sending the value destined for register 21 and finish by sending the value destined for register 1.
 - A range of clock frequencies can be used. A typical rate is 10MHz. The clock should not exceed 20MHz.
 - Setup (t_{SDI}) and hold (t_{HDI}) times are needed around the rising clock edge.
3. The ENB pin is pulled 'HIGH' and the contents of the registers are latched and take effect.
 - After clocking in the last data bit, an additional t_{HEN} should elapse before pulling the ENB signal 'HIGH'.
 - After completing these steps, the new values will affect within t_D .

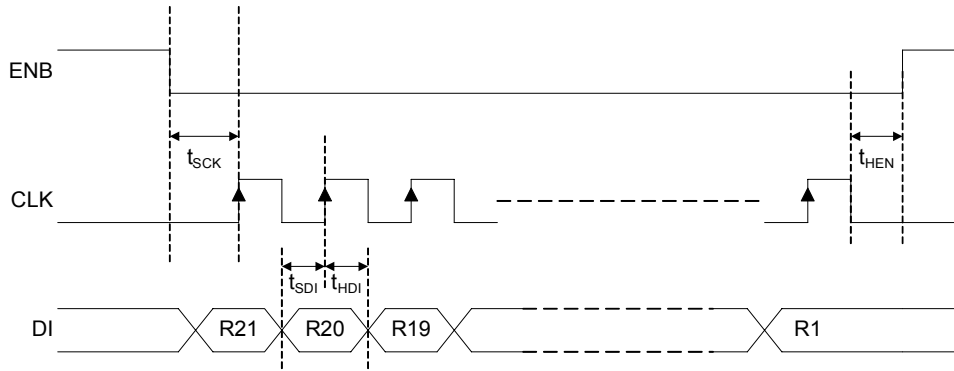

FIGURE 27. TIMING DIAGRAM FOR PROGRAMMING THE INTERNAL REGISTERS OF THE QLx4600-SL30

Programming Multiple QLx4600-SL30 Devices

The serial bus interface provides a simple means of setting the equalizer boost levels with a minimal amount of board circuitry. Many of the serial interface signals can be shared among the QLx4600-SL30 devices on a board and two options are presented in this section. The first uses common clock and serial data signals along with separate ENB signals to select which QLx4600-SL30 accepts the programmed changes. The second method uses a common ENB signal as the serial data is carried-over from one QLx4600-SL30 to the next.

Separate ENB Signals

Multiple QLx4600-SL30 devices can be programmed from a common serial data stream as shown in Figure 28. Here, each QLx4600-SL30 is provided its own ENB signal, and only one of these ENB signals is pulled 'LOW', and hence accepting the register data, at a time. In this situation, the programming of each equalizer follows the steps outlined in Figure 29.

DI /DO Carryover

The DO pin (pin 17) can be used to daisy-chain the serial bus among multiple QLx4600-SL30 chips. The DO pin outputs the overflow data from the DI pin. Specifically, as data is pipelined into a QLx4600-SL30, it proceeds according to the following flow. First, a bit goes into shadow register 1. Then, with each clock cycle, it shifts over into subsequent higher numbered registers. After shifting into register 21, it is output on the DO pin on the same clock cycle. Thus, the DO signal is equal to the DI signal, but delayed by 20 clock cycles. The timing diagram for the DO pin is shown in Figure 27 where the first 20 bits output from the DO are indefinite and subsequent bits are the data fed into the DI pin. The delay between the rising clock edge and the data transition is t_{CQ} .

A diagram for programming multiple QLx4600-SL30s is shown in Figure 30. It is noted that the board layout should ensure that the additional clock delay experienced between subsequent QLx4600-SL30s should be no more than the minimum value of t_{CQ} , i.e. 12ns.

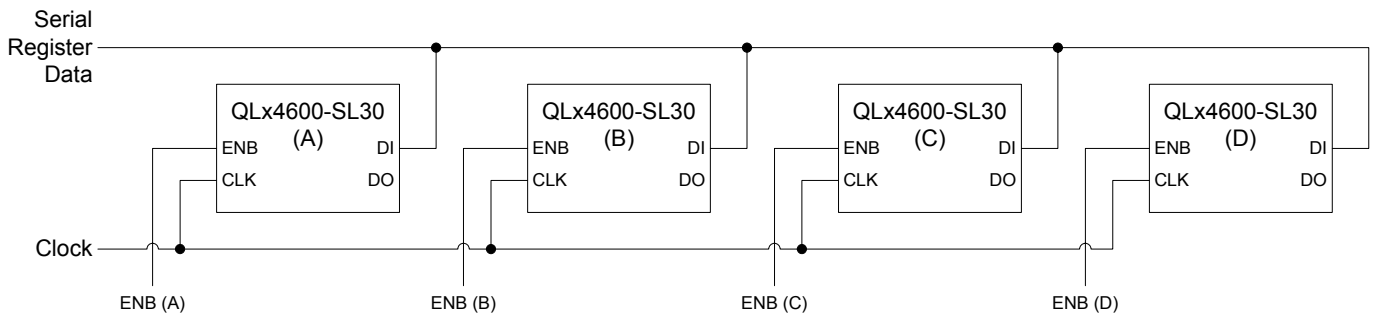

FIGURE 28. SERIAL BUS PROGRAMMING MULTIPLE QLx4600-SL30 DEVICES USING SEPARATE ENB SIGNALS

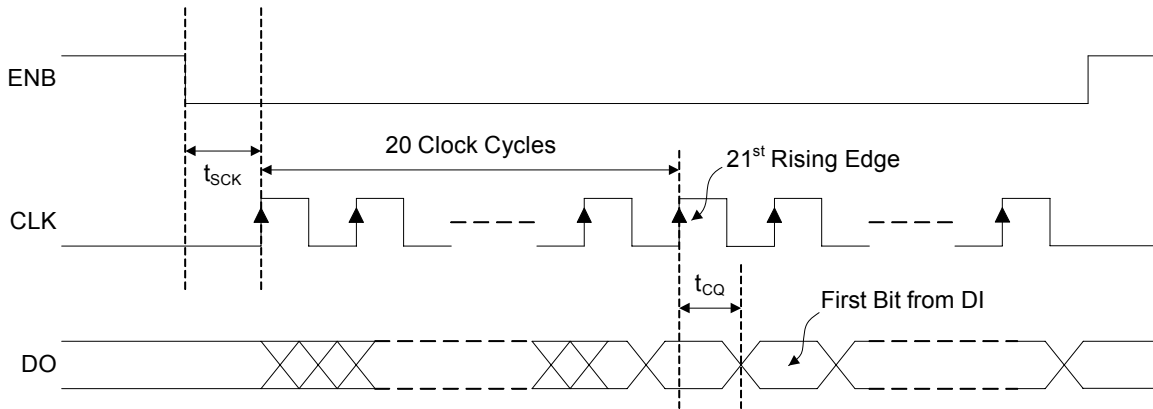

FIGURE 29. TIMING DIAGRAM FOR DI/DO CARRYOVER

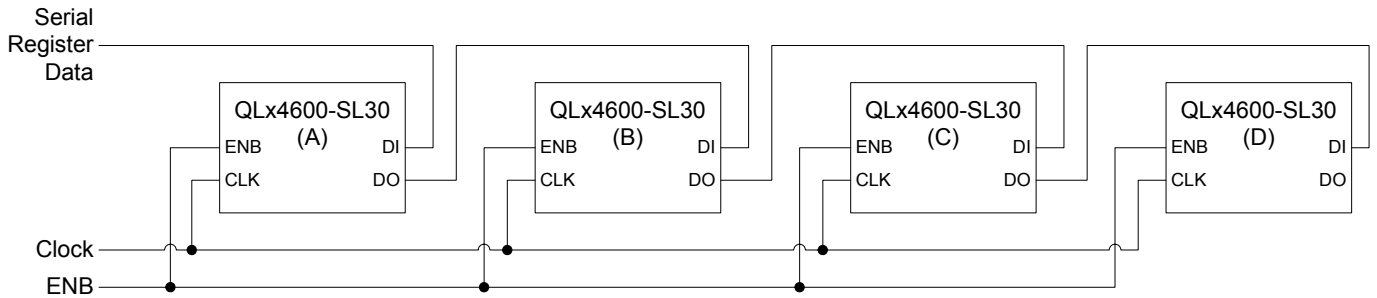

FIGURE 30. SERIAL BUS PROGRAMMING MULTIPLE QLx4600-SL30 DEVICES USING DI/DO CARRYOVER

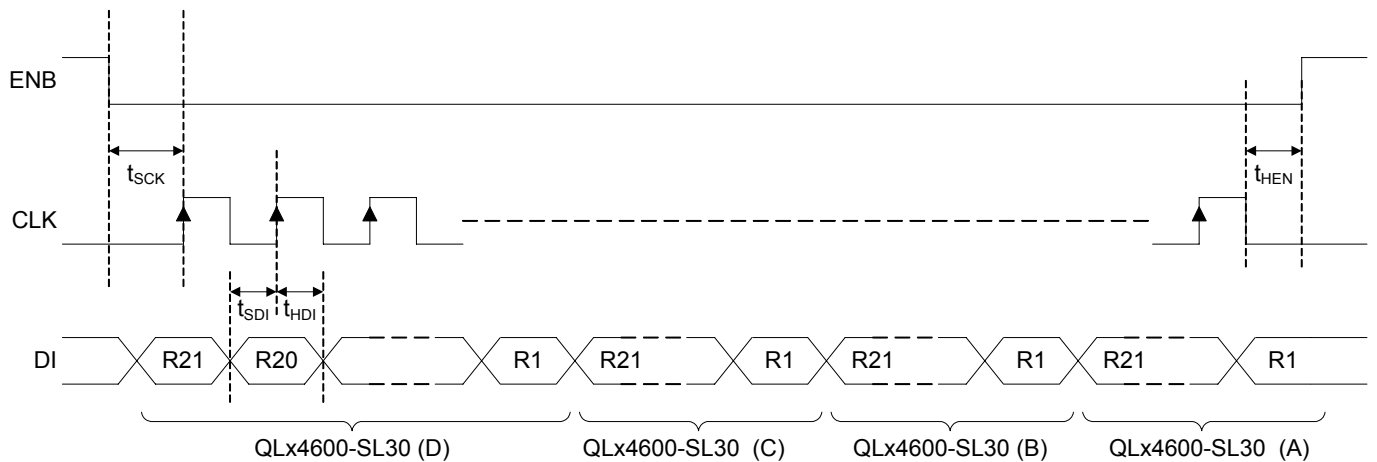

FIGURE 31. TIMING DIAGRAM FOR PROGRAMMING MULTIPLE QLx4600-SL30 DEVICES USING DI/DO CARRYOVER

Detection Threshold (DT) Pin Functionality

The QLx4600-SL30 is capable of maintaining periods of line silence on any of its four channels by monitoring each channel for loss of signal (LOS) conditions and subsequently muting the outputs of a respective channel when such a condition is detected. A reference current applied to the detection threshold (DT) pin is used to set the LOS threshold of the internal signal detection circuitry. Current control on the DT pin is done via one or two external resistors. Nominally, both a pull-up and pull-down resistor are tied to the DT pin (Figure 32A), but if adequate control of the supply voltage is maintained to within $\pm 3\%$ of 1.2V, then a simple pull-down resistor is adequate (as in Figure 32B). Resistors used should be at least 1/16W, with $\pm 1\%$ precision.

The internal bias point of the DT pin, nominally 1.05V, is used in conjunction with the voltage divider (R1 and R2) shown in Figure 32A to set the reference current on the DT pin.

Case 1: Channels with less than or equal to 25dB loss at 2.5GHz (1Gb/s to 6Gb/s):

For signals transmitted on channels having less than or equal to 25dB of loss at 2.5GHz, the optimal DT reference current is 0 μ A. This optimal reference current may be achieved by either leaving the DT pin floating, or tying the DT pin to ground (GND) with a 10M Ω resistor

Case 2: Channels with greater 25dB loss at 2.5GHz (1Gb/s to 6Gb/s):

For channels exhibiting more than 25dB of total loss (this includes cable or FR-4 loss) the DT pin should be configured for a reference sink current (coming out of the DT pin) of approximately 2 μ A. A typical configuration for a 2 μ A sink current is given in Figure 32C. If the configuration in Figure 32B is utilized, a 525k Ω resistor would be used.

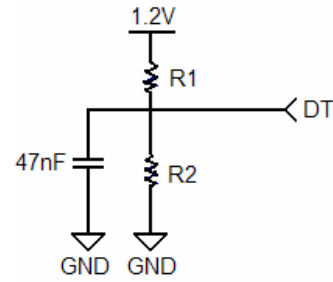

FIGURE 32A.

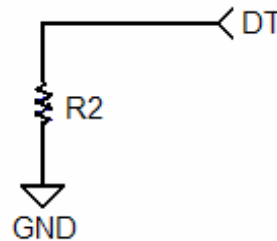

FIGURE 32B.

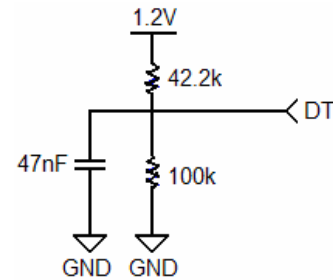

FIGURE 32C.

FIGURE 32.

Typical Application Reference Designs

Figures 33 and 34 show reference design schematics for a QLx4600-SL30 evaluation board with an SMA connector interface. Figure 33 shows the schematic for the case when the equalizer boost level is set via the CP pins. Figure 34 shows the schematic for the case when the level is set via the serial bus interface.

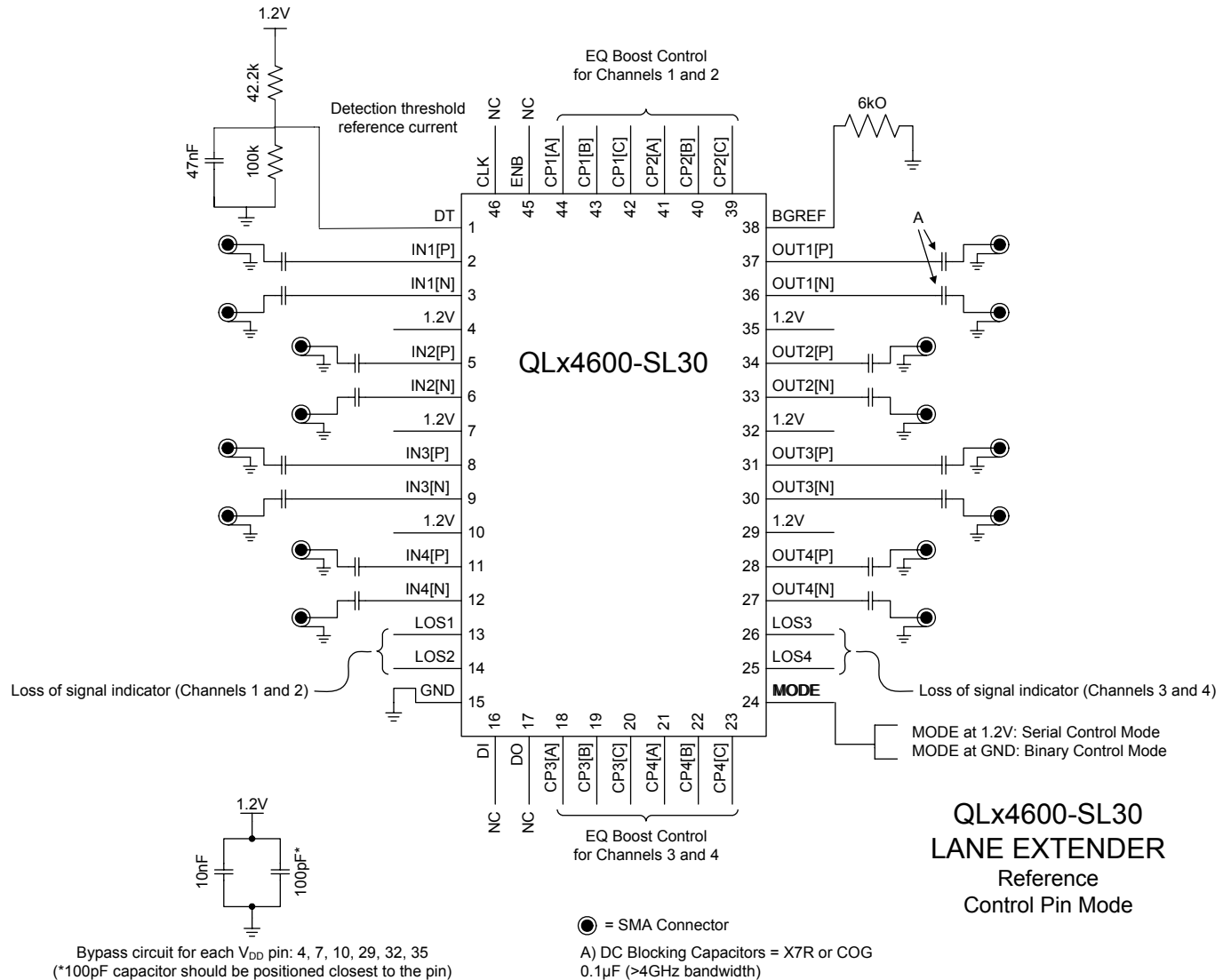

FIGURE 33. APPLICATION CIRCUIT FOR THE QLx4600-SL30 EVALUATION BOARD USING THE CONTROL PINS FOR SETTING THE EQUALIZER COMPENSATION LEVEL

Typical Application Reference Designs (Continued)

Figures 33 and 34 show reference design schematics for a QLx4600-SL30 evaluation board with an SMA connector interface. Figure 33 shows the schematic for the case when the equalizer boost level is set via the CP pins. Figure 34 shows the schematic for the case when the level is set via the serial bus interface.

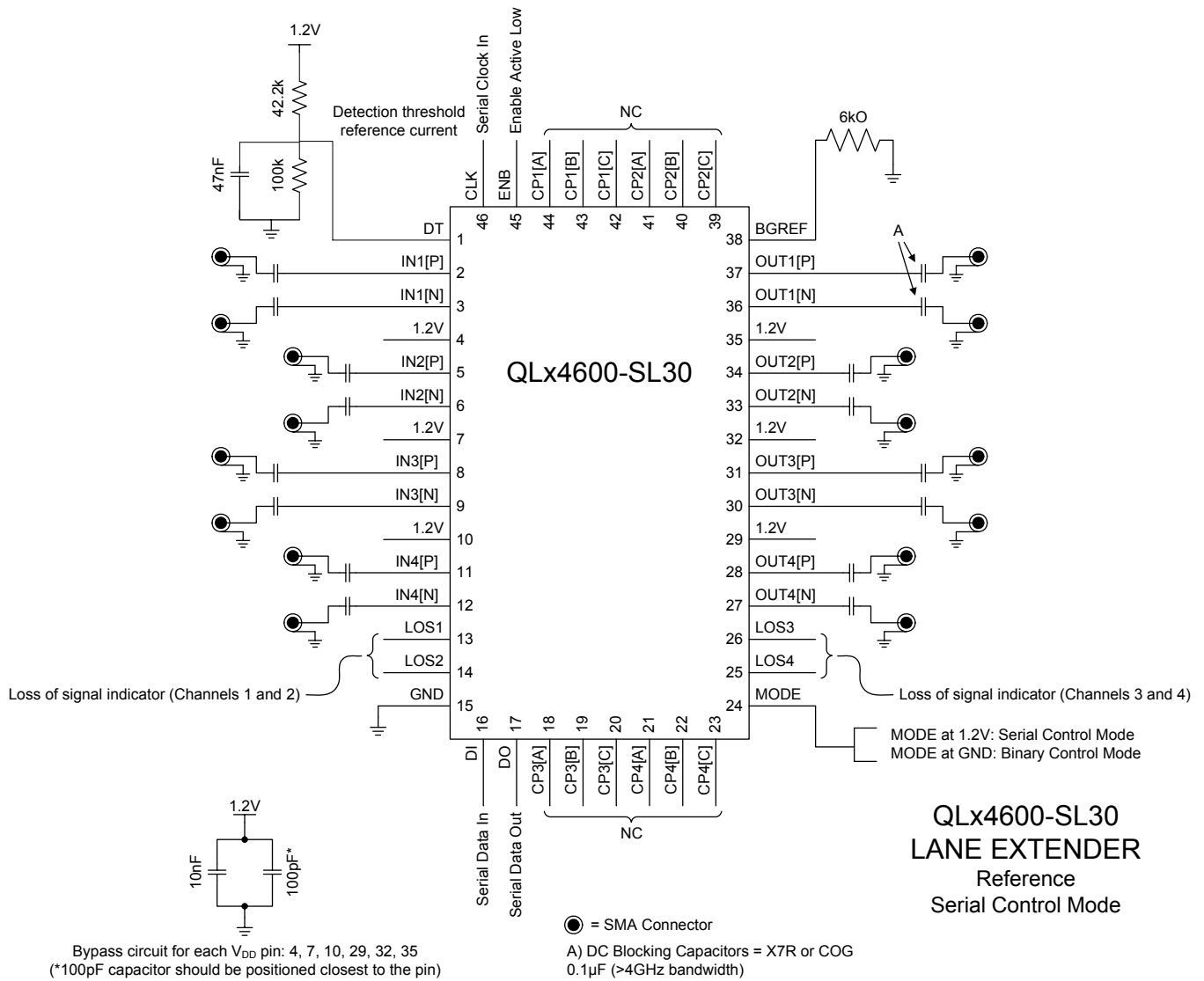

FIGURE 34. APPLICATION CIRCUIT FOR THE QLx4600-SL30 EVALUATION BOARD USING THE SERIAL BUS INTERFACE FOR SETTING THE EQUALIZER COMPENSATION LEVEL

About Q:ACTIVE®

Intersil has long realized that to enable the complex server clusters of next generation datacenters, it is critical to manage the signal integrity issues of electrical interconnects. To address this, Intersil has developed its groundbreaking Q:ACTIVE® product line. By integrating its analog ICs inside cabling interconnects, Intersil is able to achieve unsurpassed improvements in reach, power consumption, latency, and cable gauge size as well as increased airflow in tomorrow's datacenters. This new technology transforms passive cabling into intelligent "roadways" that yield lower operating expenses and capital expenditures for the expanding datacenter.

Intersil Lane Extenders allow greater reach over existing cabling while reducing the need for thicker cables. This significantly reduces cable weight and clutter, increases airflow, and reduces power consumption.

For additional products, see www.intersil.com/product_tree

Intersil products are manufactured, assembled and tested utilizing ISO9000 quality systems as noted in the quality certifications found at www.intersil.com/design/quality

Intersil products are sold by description only. Intersil Corporation reserves the right to make changes in circuit design, software and/or specifications at any time without notice. Accordingly, the reader is cautioned to verify that data sheets are current before placing orders. Information furnished by Intersil is believed to be accurate and reliable. However, no responsibility is assumed by Intersil or its subsidiaries for its use; nor for any infringements of patents or other rights of third parties which may result from its use. No license is granted by implication or otherwise under any patent or patent rights of Intersil or its subsidiaries.

For information regarding Intersil Corporation and its products, see www.intersil.com

Package Outline Drawing

L46.4x7

46 LEAD THIN QUAD FLAT NO-LEAD PLASTIC PACKAGE (TQFN)

Rev 0, 9/09

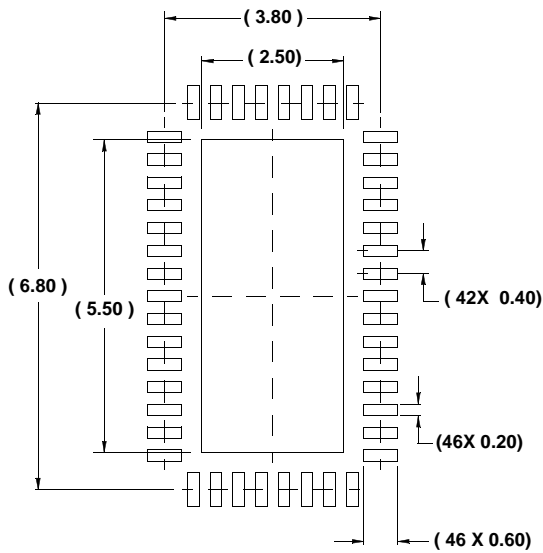
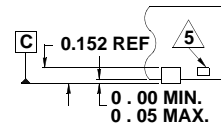
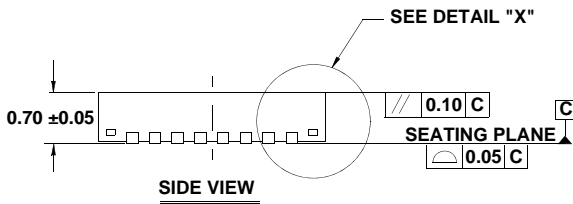
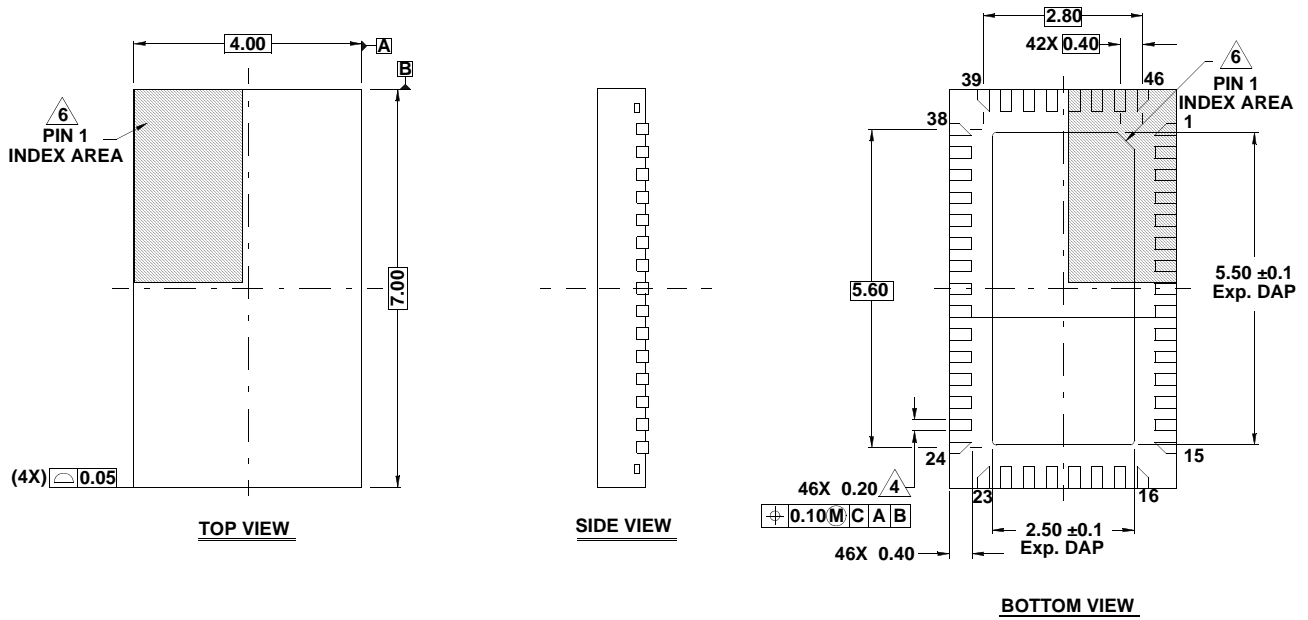

TYPICAL RECOMMENDED LAND PATTERN

NOTES:

1. Dimensions are in millimeters.
Dimensions in () for Reference Only.
2. Dimensioning and tolerancing conform to AMSE Y14.5m-1994.
3. Unless otherwise specified, tolerance : Decimal ± 0.05
4. Dimension ϕ applies to the metallized terminal and is measured between 0.15mm and 0.30mm from the terminal tip.
5. Tiebar shown (if present) is a non-functional feature.
6. The configuration of the pin #1 identifier is optional, but must be located within the zone indicated. The pin #1 identifier may be either a mold or mark feature.