

SCSI active terminator

BH9595FP-Y / BH9596FP-Y

These SCSI active terminators, developed as a substitute for conventional discrete terminators, maintain good consistency between VM level (2.85V) and GND level (0V) and between VM level and VDD level, and have extremely low power consumption, dropping to a maximum of 90 milliwatts at standby (compared to the maximum of 990 milliwatts used by conventional resistance terminators). These SCSI active terminators electrically control SCSI lines, connecting and disengaging the terminating resistor by electrically controlling the enable pin. (The enable pin is enabled at the HIGH level and switched to the High-Z state by the LOW level in the BH9595 and by the HIGH level in the BH9596, completely disconnecting the SCSI line from the SCSI terminator.)

These SCSI active terminators allow for the configuration of flexible, energy-saving SCSI networks, and are ideal for notebook computers, hard disk drives and a wide range of other products with SCSI capabilities.

●Applications

Compact disk drives, optical disk drives, CD-ROM drives, tape drives, personal computers (including laptop computers and notebook computers), workstations, mainframes, laser printers, plotters

●Features

- 1) Internal 2.85V power supply and push-pull operation, for good consistency at all signal levels.
- 2) Enable pin for terminator enabling and disconnecting, facilitating SCSI network construction.
- 3) Low power consumption, ideal for energy-saving systems.
Power consumption during standby : 90mW (compared to 990mW for conventional resistor terminators)Power consumption at 25% duty : 614mW (compared to 1,360mW for convention resistor terminators)Significant reductions in power consumption are possible.
- 4) Wide operating range.
TERM power : 4.0 ~ 5.5V (Transient : 6.0V)
- 5) Thin, microminiature design, ideal for space-saving applications.
Package body size : 13.6 × 5.4 × 1.9mm
- 6) Active termination of 18-line SCSI.
- 7) Internal thermal shutdown circuit.
- 8) Compatibility with SCSI-I and SCSI-II.

●Pin descriptions

Pin No.	Pin name
1	(N.C.) Not to be used
2	EN (Output enable)
3	SCSI Line 15
4	SCSI Line 16
5	SCSI Line 17
6	SCSI Line 18
—	GND
7	GND
8	SCSI Line 1
9	SCSI Line 2
10	SCSI Line 3
11	SCSI Line 4
12	SCSI Line 5
13	V _{DD1}

Pin No.	Pin name
14	V _{DD1}
15	SCSI Line 6
16	SCSI Line 7
17	SCSI Line 8
18	SCSI Line 9
19	SCSI Line 10
—	GND
20	SCSI Line 11
21	SCSI Line 12
22	SCSI Line 13
23	SCSI Line 14
24	VM
25	TSD (TSD signal output)

●Electrical characteristics

DC characteristics (unless otherwise noted, Ta = 25°C)

Parameter	Symbol	Min.	Typ.	Max.	Unit	Conditions
Input leakage current	I _{IL}	50	110	200	μA	V _i = GND, V _{DD1} = 5.5V
	I _{IH}	- 1	—	1	μA	V _i = V _{DD1} , V _{DD1} = 5.5V
SCSI line leakage current	I _{SLZ}	- 1	—	1	μA	EN = ENABLE* ⁴ , V _{DD1} = 5.5V
SCSI line short current * ¹	I _{SLD}	15	25	30	mA	EN = DISABLE* ⁵ , SCSI Line = GND, 4.0 ≤ V _{DD1} ≤ 5.5V
SCSI line short current * ²	I _{SLS}	7	20	30	mA	EN = DISABLE* ⁵ , SCSI Line = V _{DD1} , 4.0 ≤ V _{DD1} ≤ 5.5V
VM voltage	V _M	2.700	2.85	3.000	V	4.0 ≤ V _{DD1} ≤ 5.5V
Standby current * ¹	I _{DDSTB}	—	1.0	2.0	mA	EN = ENABLE* ⁴ , 4.0V ≤ V _{DD1} ≤ 5.5V
SCSI total sink current	I _{SLS}	300	—	550	mA	EN = DISABLE* ⁵ , 18 SCSI Line = GND, 4.0 ≤ V _{DD1} ≤ 5.5V
SCSI total drain current	I _{SLD}	300	—	550	mA	EN = DISABLE* ⁵ , 18 SCSI Line = V _{DD1} , 4.0 ≤ V _{DD1} ≤ 5.5V
SCSI equivalent resistance	R _{SL}	105	—	115	Ω	EN = DISABLE* ⁵ , SCSI Line: V _{DD1} = 4.7V
Pin capacity * ³	PC	—	5.0	6.0	pF	EN = ENABLE* ⁴

*¹ Drain Current (from Module to SCSI Line) / Line

*² Sink Current (from SCSI Line to Module) / Line

*³ Guaranteed performance

*⁴ BH9595FP-Y: EN = GND, BH9595FP-Y: EN = V_{DD1}

*⁵ BH9596FP-Y: EN = V_{DD1}, BH9596FP-Y: EN = GND

Transient characteristics (unless otherwise noted, Ta = 25°C)

Parameter	Symbol	Min.	Max.	Unit	Conditions
Load Transient Voltage 2.85V→GND	ΔVM_{TD1}	-100	100	mV	EN = DISABLE*, 4.0 ≤ V _{DD1} ≤ 5.5V All SCSI Lines: 2.85V→GND Level
Load Transient 1 / 10 decay Time 2.85V→GND	τ_{TD1}	—	100	μs	EN = DISABLE*, 4.0 ≤ V _{DD1} ≤ 5.5V All SCSI Lines: 2.85V→GND Level
Load Transient Voltage GND→2.85V	ΔVM_{TD2}	-100	100	mV	EN = DISABLE*, 4.0 ≤ V _{DD1} ≤ 5.5V All SCSI Lines: GND→2.85V Level
Load Transient 1 / 10 decay Time GND→2.85V	τ_{TD2}	—	100	μs	EN = DISABLE*, 4.0 ≤ V _{DD1} ≤ 5.5V All SCSI Lines: GND→2.85V Level
Load Transient Voltage 2.85V→V _{DD1}	ΔVM_{TS1}	-100	100	mV	EN = DISABLE*, 4.0 ≤ V _{DD1} ≤ 5.5V All SCSI Lines: 2.85V→V _{DD1} Level
Load Transient Voltage 2.85V→V _{DD1}	τ_{TS1}	—	100	μs	EN = DISABLE*, 4.0 ≤ V _{DD1} ≤ 5.5V All SCSI Lines: 2.85V→V _{DD1} Level
Load Transient Voltage V _{DD1} →2.85V	ΔVM_{TS2}	-100	100	mV	EN = DISABLE*, 4.0 ≤ V _{DD1} ≤ 5.5V All SCSI Lines: V _{DD1} →2.85V Level
Load Transient Voltage V _{DD1} →2.85V	τ_{TS2}	—	100	μs	EN = DISABLE*, 4.0 ≤ V _{DD1} ≤ 5.5V All SCSI Lines: V _{DD1} →2.85V Level

* BH9595FP-Y: EN = V_{DD1}, BH9596FP-Y: GND

The transient characteristics are guaranteed design values.

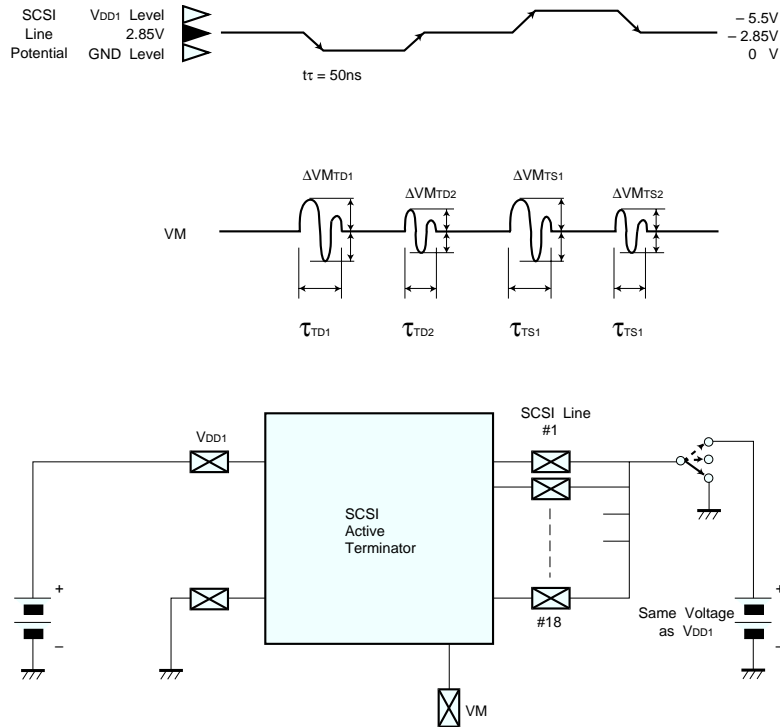

Fig. 1 Measurement of transient characteristics

● Application example

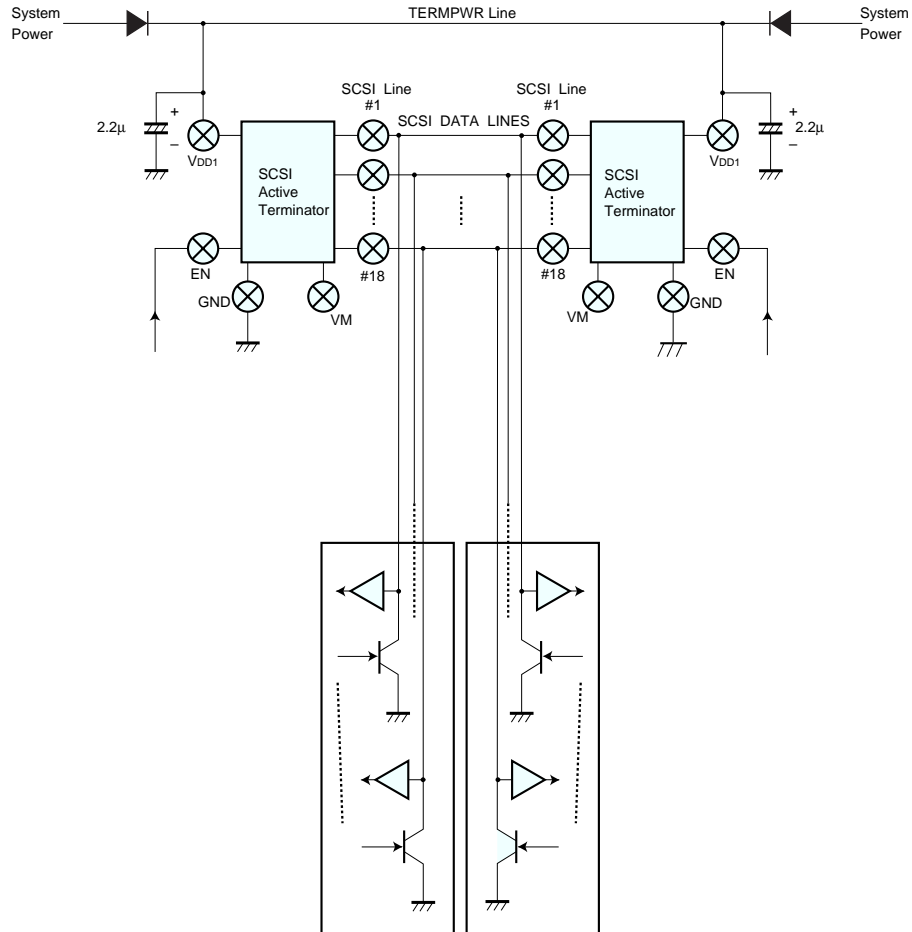

Fig. 2

●Mode selection table

Mode	BH9595FP - Y	BH9596FP - Y
Disable	L	H
Enable	H	L

●Thermal shutdown

- (1) All outputs are opened at 175°C (typically).
- (2) Temperature hysteresis is approximately 20°C.
- (3) Thermal shutdown output table

Conditions	Level
Normal	“Low”
Shutdown	“High”

●Operation notes

- (1) This terminator's operational range includes harmonic frequencies. Mount to minimize ground impedance.
- (2) Connect the V_{DD1} pin (TERMPWR) to a grounded 2.2μF bypass capacitor.

●External dimensions (Units: mm)

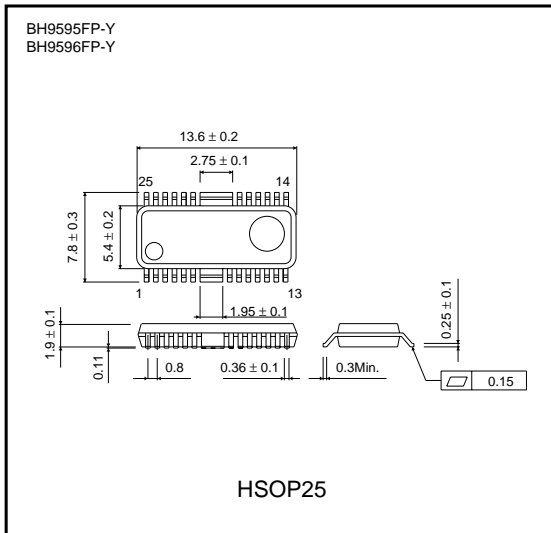

●Thermal reduction curve

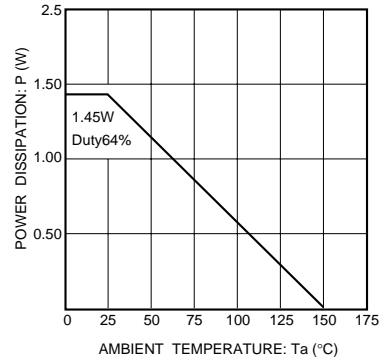

Fig. 3

- *1 When mounted on a 90 × 50 × 1.6 (mm) glass epoxy board.
- *2 Reduced by 11.6mW for each increase in Ta of 1°C over 25°C.
- *3 Can withstand continuous use of 64% duty, at 25°C.