

DESCRIPTION

The LX5205 is an eighteen line active terminator for the SCSI parallel bus. This SCSI standard recommends active termination at both ends of the SCSI bus.

During disconnect mode, the LX5205 requires a meager 500nA of supply current while offering only 2.5pF of output capacitance. To enter this low power mode, the disconnect pins can be left open (floating) or driven low thereby disconnecting the terminating resistors and placing the internal low dropout regulator into low power mode. In disconnect mode each termination line presents a high impedance to the SCSI bus with the overall effect being to preserve high signal integrity and subsequent reliable, error free communications. The LX5205 has two disconnect pins for SCSI Plug and Play (PnP) applications.

During normal operation, the LX5205 consumes only 800 μ A of current which is the lowest enabled supply current of any terminator available on the market today. Linfinity's proprietary BiCMOS low dropout regulator architecture enables this unique and very efficient operating characteristic.

The LX5205 also offers a precisely trimmed channel output current specified to a 5% tolerance. The maximum value of the output current is trimmed as closely as possible to the SCSI standard maximum specification to give the highest possible noise margin for fast SCSI operation. And finally, the LX5205 sinks up to 100mA of current making it compatible with today's fast active negation drivers.

The LX5205 is a superior, pin-for-pin replacement for the UC5607.

KEY FEATURES

- SCSI PLUG AND PLAY, DUAL LOW DISCONNECT, LOGIC LOW COMMAND DISCONNECTS ALL TERMINATION LINES
- 2.5pF OUTPUT CAPACITANCE DURING DISCONNECT
- 500nA SUPPLY CURRENT IN DISCONNECT MODE
- 800 μ A SUPPLY CURRENT DURING NORMAL OPERATION
- 100mA SINK CURRENT FOR ACTIVE NEGATION
- LOGIC COMMAND DISCONNECTS ALL TERMINATION LINES
- CURRENT LIMIT AND THERMAL PROTECTION
- COMPATIBLE WITH SCSI 1, 2, 3, AND FAST-20 STANDARDS
- HOT SWAP COMPATIBLE

IMPORTANT: For the most current data, consult Linfinity's web site: <http://www.linfinity.com>.

PRODUCT HIGHLIGHT

RECEIVING WAVEFORM - 20MHZ

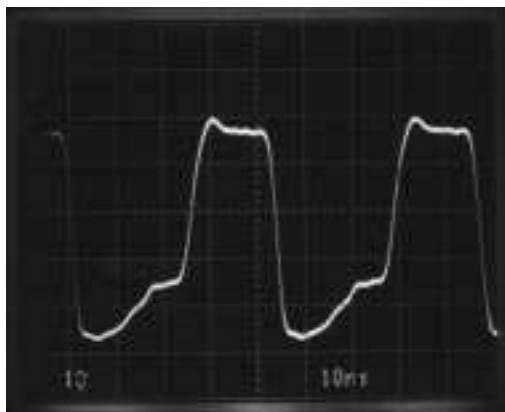

DRIVING WAVEFORM - 20MHZ

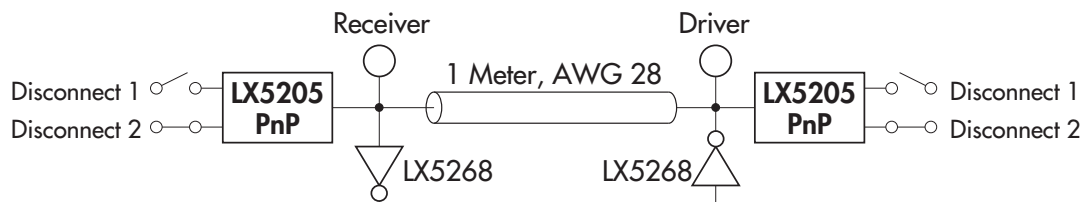
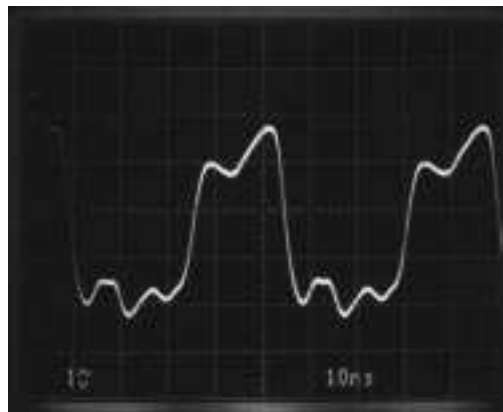

PACKAGE ORDER INFO

T _A (°C)	DWP Plastic SOWB 28-pin, Power
0 to 70	LX5205CDWP

Note: All surface-mount packages are available in Tape & Reel. Append the letter "T" to part number. (i.e. LX5205CDWPT)

NOTE:

For An In-Depth Discussion On Applying SCSI, Request Linfinity Application Note: "Understanding The Single-Ended SCSI Bus"

18-LINE PLUG AND PLAY, μ POWER SCSI TERMINATOR

PRELIMINARY DATA SHEET

ABSOLUTE MAXIMUM RATINGS (Note 1)

TermPwr Voltage	+7V
Signal Line Voltage	0V to +7V
Regulator Output Current	1.2A
Operating Junction Temperature	
Plastic (DWP Package)	150°C
Storage Temperature Range	-65°C to 150°C
Lead Temperature (Soldering, 10 seconds)	300°C

Note 1. Exceeding these ratings could cause damage to the device. All voltages are with respect to Ground. Currents are positive into, negative out of the specified terminal.

THERMAL DATA

DWP PACKAGE:

THERMAL RESISTANCE-JUNCTION TO LEADS, θ_{jL}	18°C/W
THERMAL RESISTANCE-JUNCTION TO AMBIENT, θ_{jA}	40°C/W

Junction Temperature Calculation: $T_j = T_A + (P_D \times \theta_{jA})$.

The θ_{jA} numbers are guidelines for the thermal performance of the device/pc-board system. All of the above assume no ambient airflow.

PACKAGE PIN OUTS

DISCONNECT 1	1	28	DISCONNECT 2
T1	2	27	T18
T2	3	26	T17
T3	4	25	T16
T4	5	24	T15
T5	6	23	T14
HEAT SINK/GND	7	22	HEAT SINK/GND
GND	8	21	HEAT SINK/GND
HEAT SINK/GND	9	20	HEAT SINK/GND
T6	10	19	T13
T7	11	18	T12
T8	12	17	T11
T9	13	16	T10
V _{TERM}	14	15	REG OUT

DWP PACKAGE
(Top View)

POWER UP / POWER DOWN FUNCTION TABLE

Disconnect 1	Disconnect 2	Outputs	Quiescent Current
H	H	Disabled	0.5 μ A
H	L	Enabled	800 μ A
L	H	Enabled	800 μ A
L	L	Disabled	80 μ A
Open	Open	Disabled	0.5 μ A

18-LINE PLUG AND PLAY, μ POWER SCSI TERMINATOR

PRELIMINARY DATA SHEET

RECOMMENDED OPERATING CONDITIONS (Note 2)

Parameter	Symbol	Recommended Operating Conditions			Units
		Min.	Typ.	Max.	
Tempwr Voltage	V_{TERM}	4		5.25	V
Signal Line Voltage		0		5	V
Disconnect Input Voltage		0		V_{TERM}	V
Output Capacitance on REGOUT		4.7			μ F
Operating Virtual Junction Temperature Range					
LX5205C		0		125	$^{\circ}$ C

Note 2. Range over which the device is functional.

ELECTRICAL CHARACTERISTICS

(Unless otherwise specified, these specifications apply over the operating ambient temperature range of $0^{\circ}\text{C} \leq T_A \leq 70^{\circ}\text{C}$. Tempwr = 4.75V, DISCONNECT 1 = DISCONNECT 2 = 2.2V. Low duty cycle pulse testing techniques are used which maintains junction and case temperatures equal to the ambient temperature.)

Parameter	Symbol	Test Conditions	LX5205			Units
			Min.	Typ.	Max.	
Supply Current Section						
Tempwr Supply Current		All term lines Open		0.8	1.5	mA
		All term lines 0.5V		390	415	mA
Power Down Mode		DISCONNECT 1,2 = Open		0.5	1	μ A
Output Section (Terminator Lines)						
Terminator Impedance		$I_{TERM} = -5\text{mA to } -15\text{mA}$	100	110	120	Ω
Terminator Output High Voltage			2.7	2.9		V
Max. Output Current		$V_{OUT} = 0.5\text{V}, T_A = 25^{\circ}\text{C}$	-20.3	-21.8	-23	mA
		$V_{OUT} = 0.5\text{V}, 0^{\circ}\text{C} \leq T_A \leq 70^{\circ}\text{C}$	-19.0	-21.8	-23	mA
		$V_{OUT} = 0.5\text{V}, V_{TERM} = 4\text{V}, T_A = 25^{\circ}\text{C}$	-19.5	-21.8	-23	mA
		$V_{OUT} = 0.5\text{V}, V_{TERM} = 4\text{V}$	-18.0	-21.8	-23	mA
Output Leakage		DISCONNECT 1,2 = Open, $V_{TERM} = 0\text{V to } 5.25\text{V}$		10	400	nA
Output Capacitance		DISCONNECT 1,2 = Open		2.5		pF
Sink Current		$V_{OUT} = 4\text{V}$	58	70		mA
Regulator Section						
Regulator Output Voltage				3.6		V
Line Regulation		$V_{TERM} = 4\text{V to } 6\text{V}$		10	20	mV
Load Regulation		$I_{REG} = 0 \text{ to } -100\text{mA}$		20	50	mV
Drop Out Voltage		$I_{REG} = -100\text{mA}$		0.45	1.0	V
Short Circuit Current		$V_{REG} = 0\text{V}$		-700	-1000	mA
Thermal Shutdown				150		$^{\circ}$ C
Disconnect Section						
Disconnect Threshold			0.8		2.0	V
Input Current		Disconnect 1 = Disconnect 2 = 0V		-28		μ A
		Disconnect 1 = Disconnect 2 = 2.2V		-25		μ A

BLOCK DIAGRAM

FIGURE 1 — LX5205 BLOCK DIAGRAM

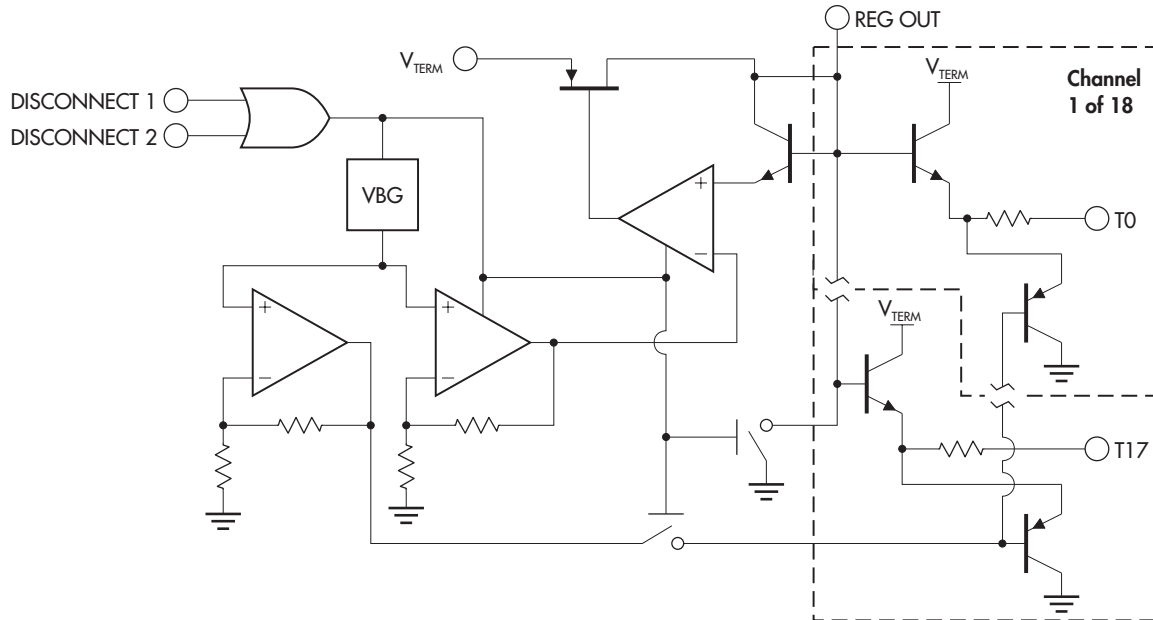

APPLICATION SCHEMATIC

FIGURE 2 — 8-BIT SCSI SYSTEM APPLICATION

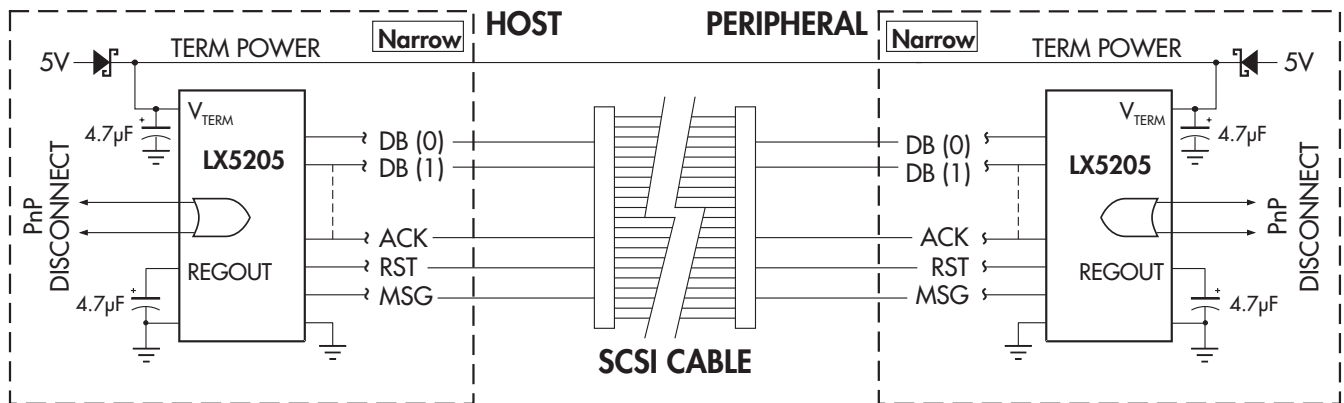

PRELIMINARY DATA - Information contained in this document is pre-production data, and is proprietary to Linfinity. It may not be modified in any way without the express written consent of Linfinity. Product referred to herein is offered in sample form only, and Linfinity reserves the right to change or discontinue this proposed product at any time.