

3.2Gbps, 4 Differential Channel, Serial Re-Driver with Equalization, De-emphasis, and Squelch

Features

- Supports data rates up to 3.2Gbps on each lane
- Optimized for SATA i/m operation
- Adjustable Transmitter De-Emphasis & Amplitude
- Adjustable Receiver Equalization
- Two Spread Spectrum Reference Clock Buffer Outputs
- Optimized for SATA applications
- Input signal level detection & output squelch on all channels
- 100-Ohm Differential CML I/O's
- Low Power (100mW per Channel)
- Standby Mode – Power Down State
- V_{DD} Operating Range: 1.5V to 1.8V
- Packaging (Pb-free & Green): 84-ball LFBGA (NB84)

Description

Pericom Semiconductor's PI2EQX3202B is a low power, signal Re-Driver. The device provides programmable equalization, amplification, and de-emphasis by using 7 select bits, SEL[0:6], to optimize performance over a variety of physical mediums by reducing Inter-symbol Interference. PI2EQX3202B supports four 100-Ohm Differential CML data I/O's between the Protocol ASIC to a switch fabric, across a backplane, or to extend the signals across other distant data pathways on the user's platform.

The integrated equalization circuitry provides flexibility with signal integrity of the signal before the Re-Driver. Whereas the integrated de-emphasis circuitry provides flexibility with signal integrity of the signal after the Re-Driver.

A low-level input signal detection and output squelch function is provided for all four channels. Each channel operates fully independently. When a channel is enabled (EN_x=1) and operating, that channels input signal level (on xI+/-) determines whether the output is enabled. If the input level of the channel falls below the active threshold level (V_{th}-) then the outputs are driven to the common mode voltage.

In addition to providing signal re-conditioning, Pericom's PI2EQX3202B also provides power management Stand-by mode operated by an Enable pin.

Block Diagram

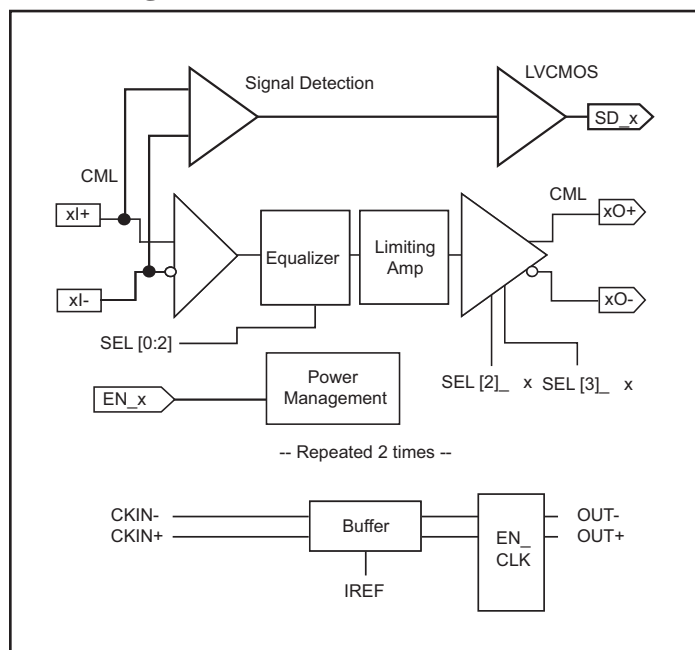

Pin Description

	1	2	3	4	5	6	7	8	9	10
A	SD_C	SD_D	SEL0_A	SEL0_B	SEL4_A	SEL4_B	SEL6_A	SEL6_B	EN_A	EN_B
B	V _{DD}	SD_B	V _{DD}	SEL1_A	SEL2_A	SEL3_A	SEL5_A	V _{DD}	EN_C	V _{DD}
C	BO+	SD_A	AI+	SEL1_B	SEL2_B	SEL3_B	SEL5_B	BI+	EN_D	AO+
D	BO-	V _{DD}	AI-	84-Ball LFBGA				BI-	GND	AO-
E	GND	V _{DD}	GND					GND	GND	GND
F	V _{DD}	GND	V _{DD}					V _{DD}	GND	V _{DD}
G	DO+	SEL0_C	CI+					DI+	SEL6_C	CO+
H	DO-	SEL0_D	CI-	V _{DD}	CKIN+	CKIN-	GND	DI-	SEL6_D	CO-
J	GND	SEL1_C	GND	SEL2_C	SEL2_D	SEL3_D	IREF	GND	SEL4_D	GND
K	EN_CLK	SEL1_D	SEL3_C	SEL4_C	OUT0+	OUT0-	OUT1+	OUT1-	SEL5_C	SEL5_D

Pin Description

Pin #	Pin Name	I/O	Description
B1, F1, D2, E2, B3, F3, H4, B8, F8, B10, F10	V _{DD}	PWR	Supply Voltage, 1.5V to 1.8V ± 0.1V
C3 D3	AI+ AI-	I	CML Input Channel A with internal 50Ω pull down
E1, J1, F2, E3, J3, H7, E8, J8, D9, E9, F9, E10, J10	GND	PWR	Supply Ground
C8 D8	BI+ BI-	I	CML Input Channel B with internal 50Ω pull down
G3 H3	CI+ CI-	I	CML Input Channel C with internal 50Ω pull down
G8 H8	DI+ DI-	I	CML Input Channel D with internal 50Ω pull down
A3, B4, B5	SEL[0:2]_A	I	Selection pins for equalizer (see Amplifier Configuration Table) w/ 50kΩ internal pull up
A4, C4, C5	SEL[0:2]_B	I	
G2, J2, J4	SEL[0:2]_C	I	
H2, K2, J5	SEL[0:2]_D	I	
B6, A5	SEL[3:4]_A	I	Selection pins for amplifier (see Amplifier Configuration Table) w/ 50kΩ internal pull up
C6, A6	SEL[3:4]_B	I	
K3, K4	SEL[3:4]_C	I	
J6, J9	SEL[3:4]_D	I	
B7, A7	SEL[5:6]_A	I	Selection pins for De-Emphasis (See De-Emphasis Configuration Table) w/ 50kΩ internal pull up
C7, A8	SEL[5:6]_B	I	
K9, G9	SEL[5:6]_C	I	
K10, H9	SEL[5:6]_D	I	
C10 D10	AO+ AO-	O	CML Output Channel A internal 50Ω pull up to V _{DD} during normal operation and 2kΩ when EN_A=0. Drives to output common mode voltage when input is <V _{TH-} .
C1 D1	BO+ BO-	O	CML Output Channel B with internal 50Ω pull up to V _{DD} during normal operation and 2kΩ when EN_B=0. Drives to output common mode voltage when input is <V _{TH-} .
G10 H10	CO+ CO-	O	CML Output Channel C with internal 50Ω pull up to V _{DD} during normal operation and 2kΩ when EN_C=0. Drives to output common mode voltage when input is <V _{TH-} .
G1 H1	DO+ DO-	O	CML Output Channel D with internal 50Ω pull up to V _{DD} during normal operation and 2kΩ when EN_D=0. Drives to output common mode voltage when input is <V _{TH-} .
A9, A10, B9, C9	EN_ [A,B,C,D]	I	Active HIGH LVCMOS signal input pins, when HIGH, it enables the CML output. When LOW, it disables the CML output (x0+, x0-) to HI-z state. Both x0+ & x0- outputs will be pulled up to V _{DD} by internal 2kΩ resistor.

(Continued)

Pin #	Pin Name	I/O	Description
H6 H5	CKIN- CKIN+	I	Differential Reference Clock Input
K5 K6	OUT0+, OUT0-	O	Differential Reference Clock Outputs
K7 K8	OUT1+, OUT1-	O	
J7	IREF	O	External 475Ω resistor connection to set the differential output current
K1	EN_CLK	I	Active HIGH LVCMOS signal input pin. When HIGH, it enables the OUTx+/OUTx- outputs. When LOW, it disables these outputs, with 50Ω to ground termination.
C2,B2,A1,A2	SD_A, SD_B, SD_C, SD_D	O	Signal detect output. Provides a LVCMOS high output when a valid input signal is detected. When low, SD_X indicates that the input signal level is below the signal detect threshold level.

Output Swing Control

SEL3_[A:D]	SEL4_[A:D]	Swing
0	0	1x
0	1	0.8x
1	0	1.2x
1	1	1.4x

Output De-emphasis Adjustment

SEL5_[A:D]	SEL6_[A:D]	De-emphasis
0	0	0dB
0	1	-2.5dB
1	0	-3.5dB
1	1	-4.5dB

Equalizer Selection

SEL0_[A:D]	SEL1_[A:D]	SEL2_[A:D]	Compliance Channel @ 1.6GHz
0	0	0	No Equalization
0	0	1	0.5dB ± 0.5dB
0	1	0	1.5dB ± 1.0dB
0	1	1	2.5dB ± 1.0dB
1	0	0	3.5dB ± 1.0dB
1	0	1	4.5dB ± 1.0dB
1	1	0	5.5dB ± 1.0dB
1	1	1	6.5dB ± 1.0dB

Maximum Ratings

(Above which useful life may be impaired. For user guidelines, not tested.)

Storage Temperature.....	-65°C to +150°C
Supply Voltage to Ground Potential.....	-0.5V to +2.5V
DC SIG Voltage.....	-0.5V to V _{DD} +0.5V
Current Output	-25mA to +25mA
Power Dissipation Continuous.....	800mW
Operating Temperature.....	0 to +70°C

Note:

Stresses greater than those listed under MAXIMUM RATINGS may cause permanent damage to the device. This is a stress rating only and functional operation of the device at these or any other conditions above those indicated in the operational sections of this specification is not implied. Exposure to absolute maximum rating conditions for extended periods may affect reliability.

AC/DC Electrical Characteristics (V_{DD} = 1.4V to 1.9V)

Symbol	Parameter	Conditions	Min.	Typ.	Max.	Units
P _s	Supply Power	EN = LVCMOS Low			0.1	W
		EN = LVCMOS High			0.6	
t _{PD}	Latency	From input to output		2.0		ns
CML Receiver Input						
V _{RX-DIFFP-P}	Differential Input Peak-to-peak Voltage		0.200			V
V _{RX-CM-ACP}	AC Peak Common Mode Input Voltage				150	mV
V _{TH-}	Signal Detect Threshold	E _{N_X} = High	50		200	mVp-p
Z _{RX-DIFF-DC}	DC Differential Input Impedance		80	100	120	Ω
Z _{RX-DC}	DC Input Impedance		40	50	60	
Equalization						
J _{RS}	Residual Jitter ^(1,2)	Total Jitter			0.3	Ulp-p
		Deterministic jitter			0.2	
J _{RM}	Random Jitter ^(1,2)			1.5		psrms

Notes

- K28.7 pattern is applied differentially at point A as shown in Figure 1.
- Total jitter does not include the signal source jitter. Total jitter (TJ) = (14.1 × RJ + DJ) where RJ is random RMS jitter and DJ is maximum deterministic jitter. Signal source is a K28.5 ± pattern (00 1111 1010 11 0000 0101) for the deterministic jitter test and K28.7 (0011111000) or equivalent for random jitter test. Residual jitter is that which remains after equalizing media-induced losses of the environment of Figure 1 or its equivalent. The deterministic jitter at point B must be from media-induced loss, and not from clock source modulation. Jitter is measured at 0V at point C of Figure 1.

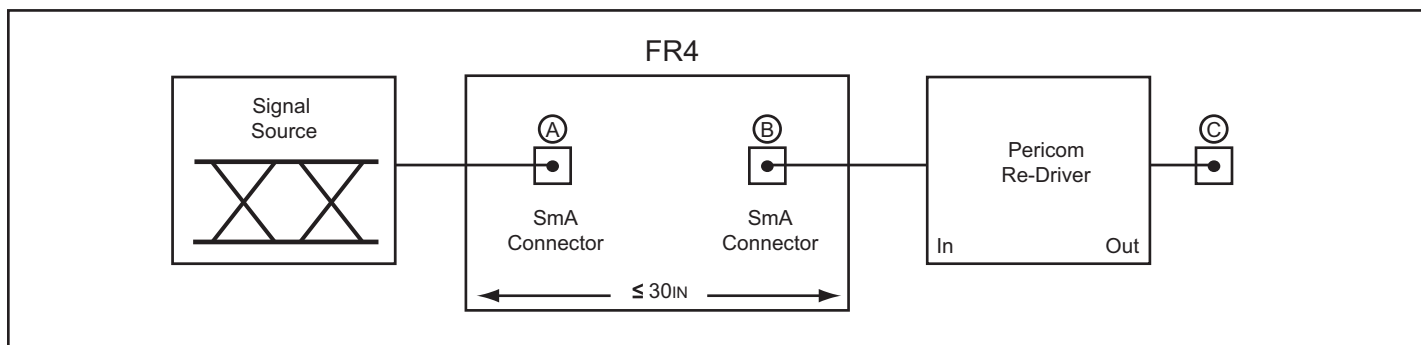

Figure 1. Test Condition Referenced in the Electrical Characteristic Table

AC/DC Electrical Characteristics ($V_{DD} = 1.4\text{V to }1.9\text{V}$)

Symbol	Parameter	Conditions	Min.	Typ.	Max.	Units
CML Transmitter Output (100-Ohm differential)						
V_{DIFFP}	Output Voltage Swing $ V_{TX-D+} - V_{TX-D-} $		200		600	mVp-p
$V_{TX-DIFFP-P}$	Output Voltage Swing $ V_{TX-D+} - V_{TX-D-} $		400 ⁽²⁾		1200 ⁽³⁾	mVp-pd
V_{TX-C} ⁽⁴⁾	Common-Mode Voltage	$ V_{TX-D+} - V_{TX-D-} / 2$		$V_{DD} - 0.3$		
t_F, t_R	Transition Time	20% to 80% ⁽¹⁾			150	ps
Z_{OUT}	Output Resistance	Single-ended	40	50	60	Ω
$Z_{TX-DIFF-DC}$	DC Differential TX Impedance		80	100	120	Ω
C_{TX}	AC Coupling Capacitor		75		200	nF
LVC MOS Control Pins						
V_{IH}	Input High Voltage		$0.65 \times V_{DD}$		V_{DD}	V
V_{IL}	Input Low Voltage				$0.35 \times V_{DD}$	
I_{IH}	Input High Current				250	μA
I_{IL}	Input Low Current				500	
LVC MOS Outputs						
V_{OH}	Output HIGH Voltage	$I_{OH} = -10\text{mA}$	$V_{DD} - 0.4$			V
V_{OL}	Output LOW Voltage	$I_{OL} = 10\text{mA}$			0.4	V

Note:

1. Using K28.7 (0011111000) pattern)
2. When 0.8x swing selected
3. When 1.4x swing selected
4. The parameter is determined by device characterization, and is not production tested

AC Switching Characteristics for Clock Buffer ($V_{DD} = 1.4$ to $1.9V$) ⁽³⁾

Symbol	Parameters	Min	Max.	Units	Notes
T_{rise} / T_{fall}	Rise and Fall Time (measured between 0.175V to 0.525V) ⁽¹⁾	125	525	ps	1
$\Delta T_{rise} / \Delta T_{fall}$	Rise and Fall Time Variation		75		1
V_{HIGH}	Voltage High including overshoot	660	900	mV	1
V_{LOW}	Voltage Low including undershoot	-150			1
V_{CROSS}	Absolute crossing point voltages	-200	550		1
ΔV_{CROSS}	Total Variation of V_{cross} over all edges	200	250		1
T_{DC}	Duty Cycle (input duty cycle = 50%) ⁽²⁾	45	55	%	2

Notes:

1. Measurement taken from Single Ended waveform.
2. Measurement taken from Differential waveform.
3. Test configuration is $R_S = 33.2\Omega$, $R_p = 49.9\Omega$, and 2pF.

Configuration Test Load Board Termination

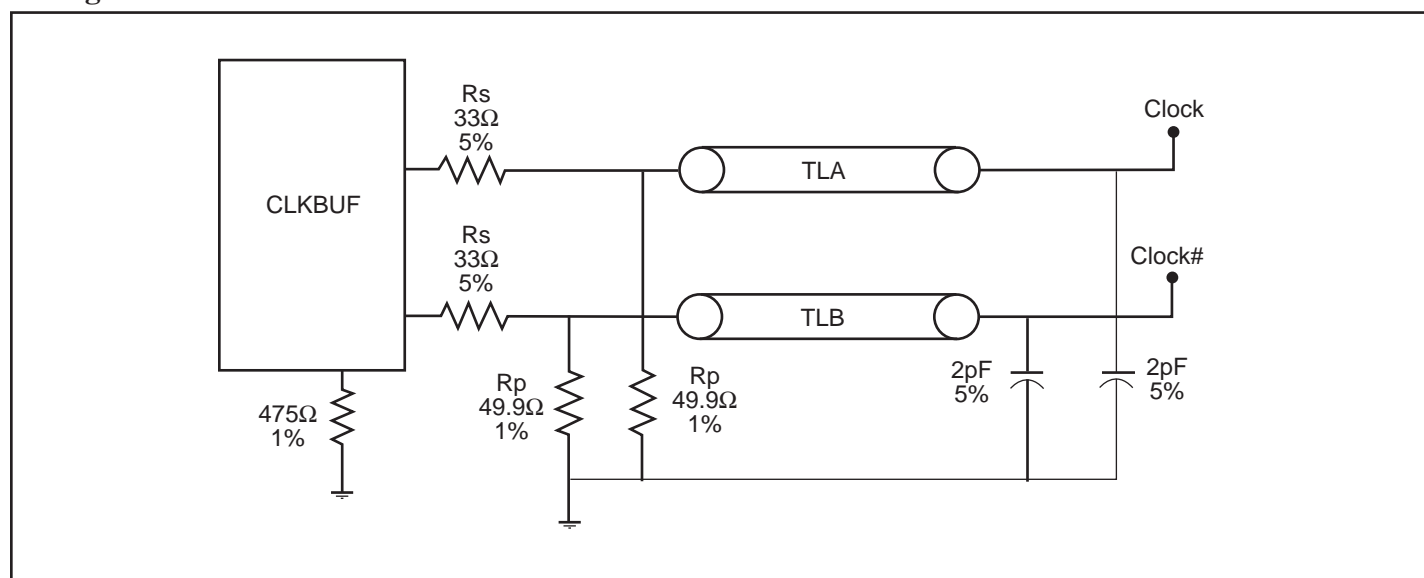
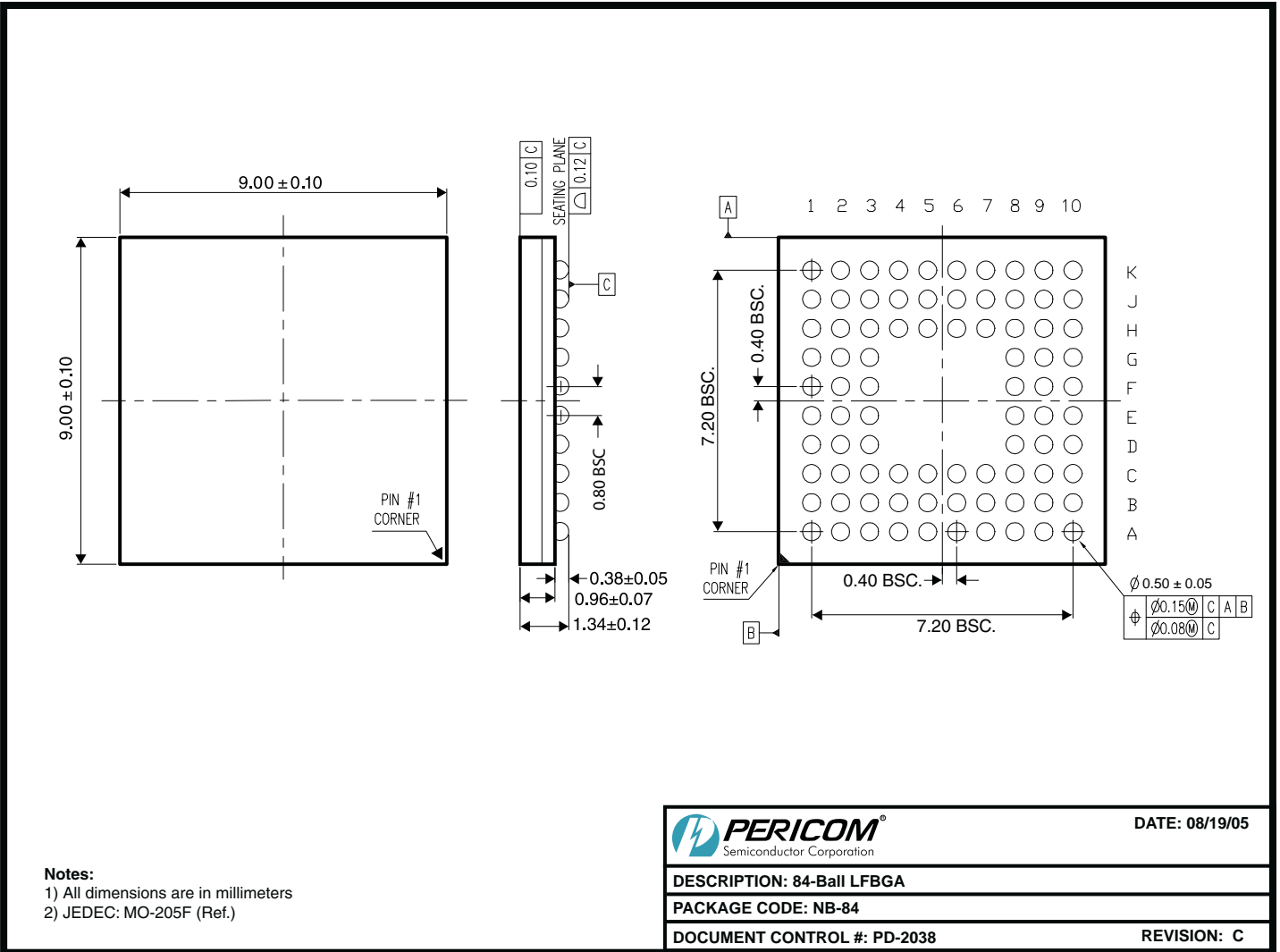

Figure 2. Configuration test load board termination

Note:

- TLB and TLB are 3" transmission lines.



Ordering Information

Ordering Number	Package Code	Package Description
PI2EQX3202BNBE	NB	Pb-free & Green 84-Ball LFBGA

Notes:

- Thermal characteristics can be found on the company web site at www.pericom.com/packaging/
- E = Pb-free and Green
- X suffix = Tape/Reel