

# LM2512

## Mobile Pixel Link Level 0, 24-Bit RGB Display Interface Serializer with Dithering and Look Up Table Option — —

### NOT RECOMMENDED FOR NEW DESIGN - See LM2512A

#### General Description

The LM2512 is a MPL Serializer (SER) that performs a 24-bit to 18-bit Dither operation and serialization of the video signals to Mobile Pixel link (MPL) levels on only 3 or 4 active signals. An optional Look Up Table (Three X 256 X 8 bit RAM) is also provided for independent color correction. 18-bit Bufferless or partial buffer displays from QVGA (320 x 240) up to VGA (640 x 480) pixels can utilize a 24-bit video source.

The interconnect is reduced from 28 signals to only 3 or 4 active signals with the LM2512 and companion deserializer easing flex interconnect design, size constraints and cost.

The LM2512 SER resides by the application, graphics or baseband processor and translates the wide parallel video bus from LVCMOS levels to serial Mobile Pixel Link levels for transmission over a flex cable (or coax) and PCB traces to the DES located near or in the display module.

When in Power\_Down, the SER is put to sleep and draws less than 10µA. The link can also be powered down by stopping the PCLK (DES dependant) or by the PD\* input pins.

The LM2512 implements the physical layer of the MPL Level 0 Standard (MPL-0) and a 450 µA I<sub>OMS</sub> current (Class 0).

#### Features

- 24-bit RGB Display Interface support up to 640 x 480 VGA formats
- 24 to 18-bit Dithering
- Optional Look Up Table for independent color correction
- MPL-Level 0 Physical Layer
- SPI Interface for Look Up Table control and loading
- Low Power Consumption & Powerdown state
- Level translation between host and display
- Optional Auto Power Down on STOP PCLK
- Frame Sequence bits automatically resync upon data or clock error
- 1.6V to 2.0V core / analog supply voltage
- 1.6V to 3.0V I/O supply voltage range

#### System Benefits

- Dithered Data Reduction
- Independent RGB Color Correction
- 24-bit Color Input
- Small Interface
- Low Power
- Low EMI
- Intrinsic Level Translation

#### Typical 3 MD Lane Application Diagram - Bridge Chip

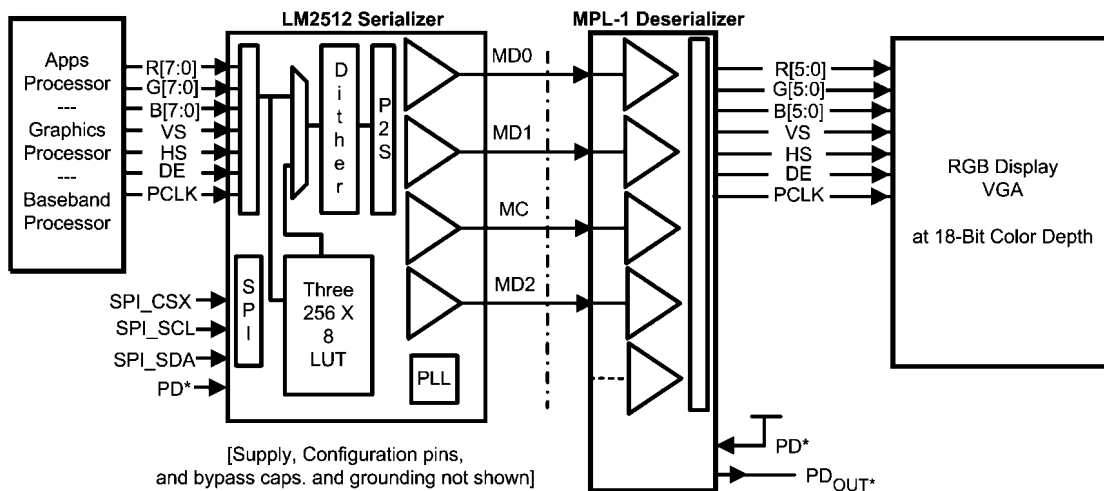

20172801

LM2512 Mobile Pixel Link Level 0, 24-Bit RGB Display Interface Serializer with Dithering and Look Up Table Option - NOT RECOMMENDED FOR NEW DESIGN - See LM2512A

## Ordering Information

NSID	Package Type	Package ID
LM2512SM	49L UFBGA, 4.0 X 4.0 X 1.0 mm, 0.5 mm pitch	SLH49A
LM2512SN	40L LLP, 6.0 X 6.0 X 0.4 mm, 0.5 mm pitch	SNA40A

## Pin Descriptions

Pin Name	No. of Pins	I/O, Type	Description RGB Serializer
<b>MPL SERIAL BUS PINS</b>			
MD[2:0]	3	O, MPL	MPL Data Line Driver
MC	1	O, MPL	MPL Clock Line Driver
<b>SPI INTERFACE and CONFIGURATION PINS</b>			
SPI_CSX	1	I, LVCMOS	SPI_Chip Select Input SPI port is enabled when: SPI_CSX is Low, PD* is High, and PCLK is static.
SPI_SCL	1	I, LVCMOS	SPI_Clock Input
SPI_SDA/HS	1	IO, LVCMOS	Multi-function Pin: If SPI_CSX is Low, this is the SPI_SDA IO signal. Default is Input. Pin will be an output for a SPI Read transaction. See HS description below also.
PD*	1	I, LVCMOS	Power Down Mode Input SER is in sleep mode when PD* = Low, SER is enabled when PD* = High In PD*=L - Sleep mode: SPI interface is OFF, Register settings are <b>RESET</b> , and LUT data is retained.
RES1	1	I, LVCMOS	<b>Reserved 1 - Tie High (V<sub>DDIO</sub>) only available on SLH49A package</b>
TM	1	I LVCMOS	Test Mode <b>L = Normal Mode, tie to GND</b> H = Test Mode (Reserved)
NC	1	NA	Not Connected - Leave Open; only on SLH49A package..
<b>VIDEO INTERFACE PINS</b>			
PCLK	1	I, LVCMOS	Pixel Clock Input Video Signals are latched on the <b>RISING</b> edge.
R[7:0] G[7:0] B[7:0]	24	I, LVCMOS	RGB Data Bus Inputs – Bit 7 is the MSB.
VS	1	I, LVCMOS	Vertical Sync. Input <b>This signal is used as a frame start for the Dither block and is required.</b> The VS signal is serialized unmodified.
SPI_SDA/HS	1	IO, LVCMOS	Multi-function Pin: Horizontal Sync. Input (when SPI_CSX = High) See SPI_SDA description above also.
DE	1	I, LVCMOS	Data Enable Input
<b>POWER/GROUND PINS</b>			
V <sub>DDA</sub>	1	Power	Power Supply Pin for the PLL (SER) and MPL Interface. 1.6V to 2.0V
V <sub>SSA</sub>	1	Ground	Ground Pin for the PLL (SER) and MPL Interface.
V <sub>DD</sub>	1	Power	Power Supply Pin for the digital core. 1.6V to 2.0V
V <sub>SS</sub>	1	Ground	Ground Pin for the digital core. For SNA40A package, this is the large center pad.
V <sub>DDIO</sub>	3	Power	Power Supply Pin for the parallel interface I/Os. 1.6V to 3.0V
V <sub>SSIO</sub>	4	Ground	Ground Pin for the parallel interface I/Os. For SNA40A package, this is the large center pad.

**Note:**

I = Input, O = Output, IO = Input/Output. **Do not float input pins.**

**Absolute Maximum Ratings** (Note 1)

If Military/Aerospace specified devices are required, please contact the National Semiconductor Sales Office/ Distributors for availability and specifications.

Supply Voltage ( $V_{DDA}$ )	-0.3V to +2.2V
Supply Voltage ( $V_{DD}$ )	-0.3V to +2.2V
Supply Voltage ( $V_{DDIO}$ )	-0.3V to +3.3V
LVC MOS Input/Output Voltage	-0.3V to ( $V_{DDIO}$ +0.3V)
MPL Output Voltage	-0.3V to $V_{DDA}$
Junction Temperature	+150°C
Storage Temperature	-65°C to +150°C

## ESD Ratings:

HBM, 1.5 k $\Omega$ , 100 pF	$\geq \pm 2$ kV
EIAJ, 0 $\Omega$ , 200 pF	$\geq \pm 200$ V

Maximum Package Power Dissipation Capacity at 25°C	
SLH49A Package	2.5 W

SNA40A Package	3.2 W
Derate SLH49A Package above 25°C	25 mW/°C
Derate SNA40A Package above 25°C	26 mW/°C

**Recommended Operating Conditions**

	Min	Typ	Max	Units
Supply Voltage				
$V_{DDA}$ to $V_{SSA}$ and $V_{DD}$ to $V_{SS}$	1.6	1.8	2.0	V
$V_{DDIO}$ to $V_{SSIO}$	1.6		3.0	V
PClock Frequency (4X)	7.5		22.5	MHz
PClock Frequency (6X)	5		15	MHz
MC Frequency	30		90	MHz
Ambient Temperature	-30	25	85	°C

**Electrical Characteristics**

Over recommended operating supply and temperature ranges unless otherwise specified. (Notes 2, 3)

Symbol	Parameter	Conditions	Min	Typ	Max	Units	
<b>MPL</b>							
$I_{OLL}$	Logic Low Current (5X $I_B$ )		3.66 $I_B$	5.0 $I_B$	7.33 $I_B$	$\mu$ A	
$I_{OMS}$	Mid Scale Current			3.0 $I_B$		$\mu$ A	
$I_{OLH}$	Logic High Current (1X $I_B$ )		0.70 $I_B$	1.0 $I_B$	1.47 $I_B$	$\mu$ A	
$I_B$	Current Bias			150		$\mu$ A	
$I_{OFF}$	MPL Leakage Current	$V_{MPL} = 0V$	-2		+2	$\mu$ A	
<b>LVC MOS (1.6V to 3.0V Operation)</b>							
$V_{IH}$	Input Voltage High Level		0.7 $V_{DDIO}$		$V_{DDIO}$	V	
$V_{IL}$	Input Voltage Low Level		GND		0.3 $V_{DDIO}$	V	
$V_{HY}$	Input Hysteresis			100		mV	
$I_{IN}$	Input Current		-1	0	+1	$\mu$ A	
$V_{OH}$	Output Voltage High Level	SPI_SDA		0.7 $V_{DDIO}$	$V_{DDIO}$	V	
$V_{OL}$	Output Voltage Low Level			$V_{SSIO}$	0.2 $V_{DDIO}$	V	
<b>SUPPLY CURRENT</b>							
$I_{DD}$	Total Supply Current - Enabled (Note 4)	MC = 80 MHz, Checkerboard Pattern 3 MD Lane (Note 5)	$V_{DDIO}$		0.02	0.07	mA
			$V_{DD}/V_{DDA}$		3.9	7	mA
	Supply Current -Enabled	MC = 60 MHz, Checkerboard Pattern 2 MD Lane	$V_{DDIO}$		0.01		mA
			$V_{DD}/V_{DDA}$		2.6		mA
$I_{DDZ}$	Supply Current—Disable Power Down Modes $T_a = 25^\circ\text{C}$ , (Note 12)	PD* = L	$V_{DDIO}$		<1	2	$\mu$ A
			$V_{DD}/V_{DDA}$		<1	5	$\mu$ A
	Stop Clock	$V_{DDIO}$		<1	2	$\mu$ A	
		$V_{DD}/V_{DDA}$		<1	5	$\mu$ A	

## Switching Characteristics

Over recommended operating supply and temperature ranges unless otherwise specified. (Note 2)

Symbol	Parameter	Conditions	Min	Typ	Max	Units
<b>PARALLEL BUS TIMING</b>						
$t_{SET}$	Set Up Time	SER Inputs <i>Figure 1</i>	5			ns
$t_{HOLD}$	Hold Time		5			ns
<b>SERIAL BUS TIMING</b>						
$t_{DVBC}$	Serial Data Valid before Clock Edge	SER Data Pulse Width <i>Figure 2</i> , (Notes 10, 11)	0.3			UI
$t_{DVAC}$	Serial Data Valid after Clock Edge		0.3			UI
<b>POWER UP TIMING</b>						
$t_0$	Bias Up Time	<i>Figure 9</i>		200		PCLK cycles
$t_1$	MC Pulse Width LOW			200		PCLK cycles
$t_2$	MC Pulse Width HIGH			20		PCLK cycles
$t_3$	MC Pulse LOW			8		PCLK cycles
$t_4$	MC Pulse LOW - SER PLL Lock Counter			600		PCLK cycles
$t_{PZXclk}$	Enable Time - Clock Start	PCLK to MC <sub>OUT</sub> <i>Figure 4</i>		(Note 6)		
<b>MPL POWER OFF TIMING</b>						
$t_{PAZ}$	Disable Time to Power Down	(Note 8)			15	ms
$t_{PXZclk}$	Disable Time - Clock Stop	PCLK to MC <sub>OUT</sub> <i>Figure 3</i>		2		PCLK cycles
<b>SPI INTERFACE</b>						
$t_{ACC}$	SPI Data Active (SDA_device)	<i>Figure 16</i>	0		50	ns
$t_{OHR}$	SPI Data Tri-State (SDA_device)		0		50	ns

## Recommended Input Timing Requirements (PCLK and SPI)

Over recommended operating supply and temperature ranges unless otherwise specified. (Note 2)

Symbol	Parameter	Conditions	Min	Typ	Max	Units
<b>PIXEL CLOCK (PCLK)</b>						
$f_{PCLK}$	Pixel Clock Frequency	3 MD Lane, (4X)	7.5		22.5	MHz
		2 MD Lane, (6X)	5		15	MHz
$PCLK_{DC}$	Pixel Clock Duty Cycle		30	50	70	%
$t_T$	Transition Time	(Notes 7, 11)	2	>2		ns
$t_{STOPpclk}$	Clock Stop Gap	(Notes 9, 11)	4	2		PCLK cycles
<b>SPI INTERFACE</b>						
$f_{SCLw}$	SCL Frequency	WRITE			10	MHz
$f_{SCLr}$		READ			6.67	MHz
$t_{s0}$	CSX Set Time	Figure 15	60			ns
$t_{s1}$	SI Set Time		30			ns
$t_{h1}$	SI Hold Time		30			ns
$t_{w1h}$	SCL Pulse Width High	Figures 15, 16	WRITE	35		ns
			READ	60		ns
$t_{w1l}$	SCL Pulse Width Low		WRITE	35		ns
			READ	60		ns
$t_r$	SCL Rise Time	Figure 15		5		ns
$t_f$	SCL Fall Time			5		ns
$t_{0H}$	SI Hold Time		30			ns
$t_{h0}$	CSX Hold Time		65			ns
$t_{w2}$	CSX OFF Time		100			ns

**Note 1:** "Absolute Maximum Ratings" are those values beyond which the safety of the device cannot be guaranteed. They are not meant to imply that the device should be operated at these limits. The tables of "Electrical Characteristics" specify conditions for device operation.

**Note 2:** Typical values are given for  $V_{DDIO} = 1.8V$  and  $V_{DD} = V_{DDA} = 1.8V$  and  $T_A = 25^\circ C$ .

**Note 3:** Current into a device pin is defined as positive. Current out of device pins is defined as negative. Voltages are referenced to Ground unless otherwise specified.

**Note 4:** For IDD tests - input signal conditions are: (swing, edge, freq, DE = H, VS = L, HS = L, RGB Checkerboard Pattern: AAAAAA-555555)

**Note 5:** Total Supply Current Conditions: checkerboard data pattern, 20MHz PCLK (3MDs), TYP  $V_{DDIO} = V_{DDA} = V_{DD} = 1.8V$ , MAX  $V_{DDIO} = 3.0V$ , MAX  $V_{DDA} = V_{DD} = 2.0V$ .

**Note 6:** Enable Time is a complete MPL start up comprised of  $t_0 + t_1 + t_2 + t_3 + t_4$ .

**Note 7:** Maximum transition time is a function of clock rate and should be less than 30% of the clock period to preserve signal quality.

**Note 8:** Guaranteed functionally by the  $I_{DDZ}$  parameter. See also Figure 10.

**Note 9:** This is the minimum time that the PCLK needs to be held off for in order for the device to be reset. Once PCLK is reapplied, a PLL Lock is required and start up sequence before video data is serialized.

**Note 10:** 1 UI is the serial data MD pulse width =  $1 / 8 \times PCLK$  (3 MD lanes)

**Note 11:** This is a functional parameter and is guaranteed by design or characterization.

**Note 12:** Upon power-up, the LUT SRAMs may not be in their lowest power state. To ensure that the SRAMs have entered their lowest power state, a single SPI access to each of the three SRAMs is recommended. The  $IDDz$  current specification assumes that each of the three SRAMs has been accessed at least once. For additional information, please refer to the "Power Up Sequence" section in the datasheet.

# Timing Diagrams

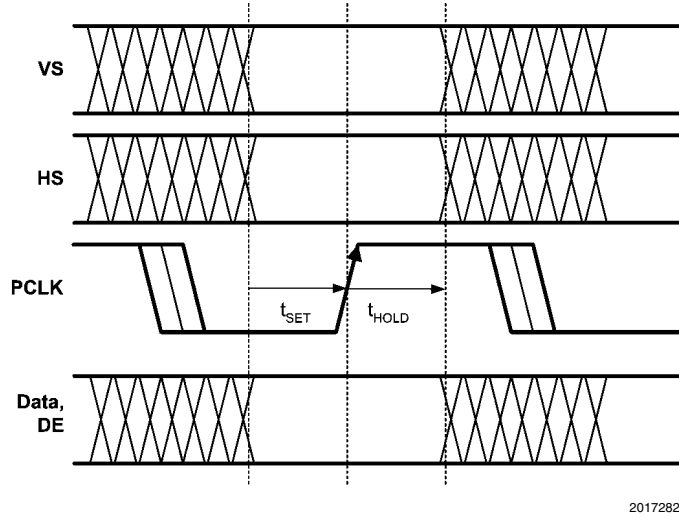

20172826

**FIGURE 1. Input Timing for RGB Interface**

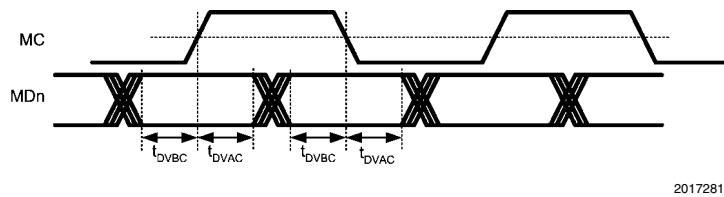

20172816

**FIGURE 2. Serial Data Valid**

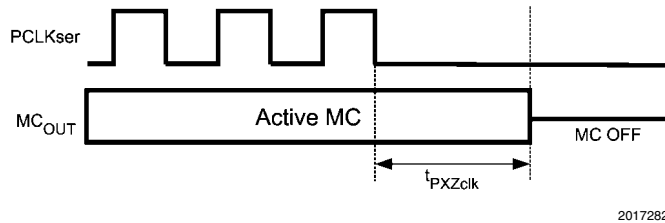

20172829

**FIGURE 3. Stop PClock Power Down**

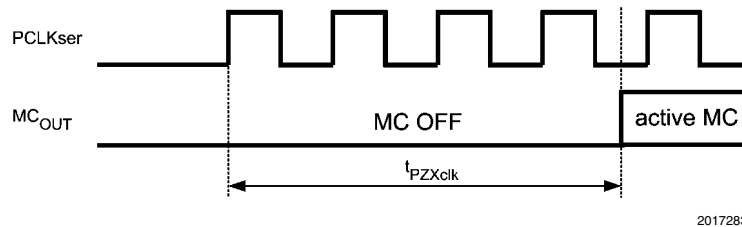

20172830

**FIGURE 4. Stop PClock Power Up**

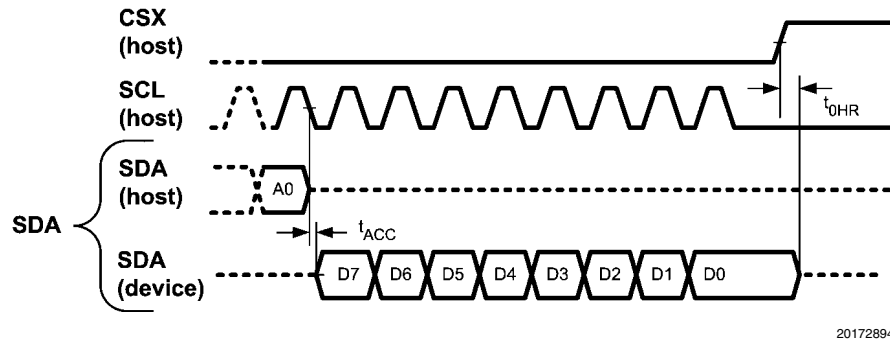

20172894

FIGURE 5. SPI Interface

## Functional Description

The LM2512 is a Mobile Pixel Link (MPL) Serializer that serializes a 24-bit RGB plus three control signals (VS, HS, and DE) to two or three MPL MD lines plus the serial clock MC. The 24-bit RGB data is dithered to 18 bits by the Serializer.

An optional Look Up Table consisting of three 256 X 8-bit RAMs may also be used and is controlled via a 3-wire SPI interface. The LM2512 is compatible with certain discrete MPL Deserializers and also Display Drivers with integrated MPL Deserializers.

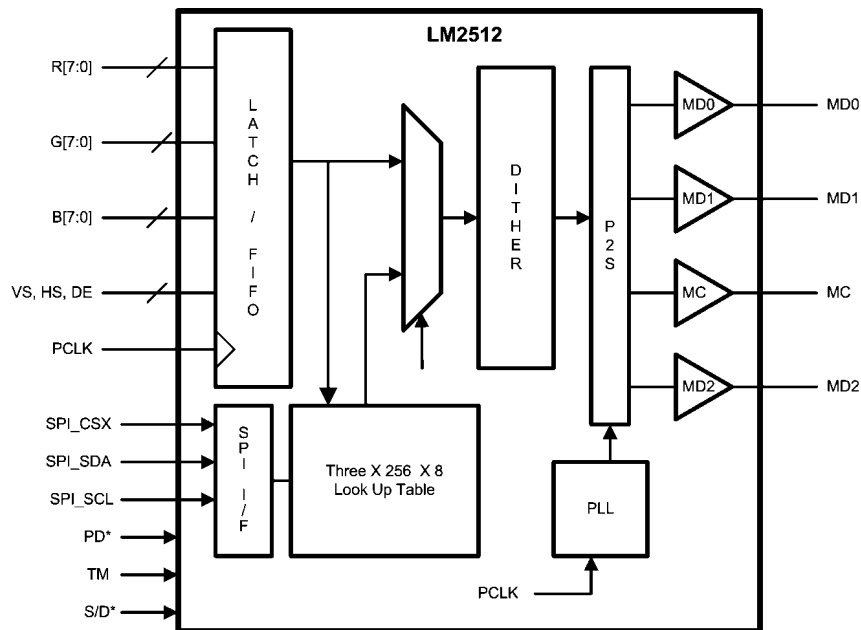

20172892

FIGURE 6. General LM2512 Block Diagram

## BUS OVERVIEW

The LM2512 is a multi-lane MPL Serializer that supports a 24-bit RGB source interface. The MPL physical layer is purpose-built for an extremely low power and low EMI data transmission while requiring the fewest number of signal lines. No external line components are required, as termination is provided internal to the MPL receiver. A maximum raw throughput of 480 Mbps (3-lane raw) is possible with this chipset. The MPL interface is designed for use with common 50Ω to 100Ω lines using standard materials and connectors. Lines may be microstrip or stripline construction. Total length of the interconnect is expected to be less than 20cm.



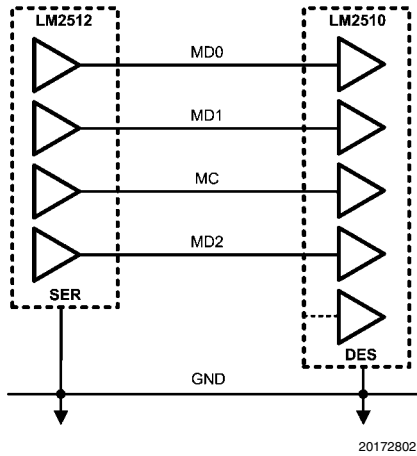

FIGURE 7. Three MD Lane MPL Interface

### SERIAL BUS TIMING

Data valid is relative to both edges of a RGB transaction as shown in *Figure 8*. Data valid is specified as: Data Valid before Clock, Data Valid after Clock, and Skew between data lines should be less than 500ps.

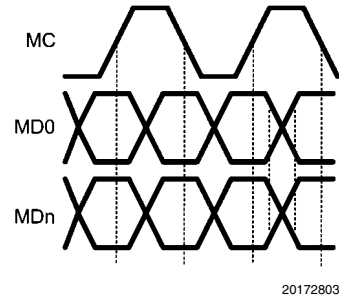

FIGURE 8. Dual Link Timing

### SERIAL BUS PHASES

There are three bus phases on the MPL serial bus. These are determined by the state of the MC and MD lines. The MPL bus phases are shown in *Table 1*.

The LM2512 supports MPL Level 0 Enhanced Protocol with a Class 0 PHY.

TABLE 1. Link Phases

Name	MC State	MDn State	Phase Description	Pre-Phase	Post-Phase
OFF (O)	0	0	Link is Off	A, or LU	LU
LINK-UP (LU)	0LHL	000L	Start Up Pulse	O	A or O
Active (A)	A	X	Streaming Data	LU	O

#### Notes on MC/MD Line State:

0 = no current (off)

L = Logic Low—The higher level of current on the MC and MD lines

H = Logic High—The lower level of current on the MC and MD lines

X = Low or High

A = Active Clock

### SERIAL BUS START UP TIMING

In the Serial Bus OFF phase, SER line drivers for MDs and MC are turned off such that zero current flows over the MPL lines. On the SER side, when the PD\* input pin is de-asserted (driven High), or with PD\* = High and the PCLK is turned on, the SER will power up its bias block during  $t_0$ .

The SER will next drive the MC line to the logic Low (5I current) state for 200 PCLK cycles ( $t_1$ ). The DES devices detects the current flowing in the MC line, and powers up its analog circuit blocks (or alternately is controlled by its PD\* input pin - device specific).

The SER then drives the MC line to a logic High (1I current) for 20 PCLK cycles ( $t_2$ ). On the MC low-to-high transition, the

DES samples the current and optimizes its current sources to match that of the drivers.

The MC is now driven to a logic Low (5I current) for 8 PCLK cycles ( $t_3$ ).

Next the SER PLL is locked to the PCLK. A hold off counter of 600 PCLK cycles is used to hold off until the PLL has locked and is stable ( $t_4$ ). At this point, streaming RGB information is now sent across the MPL link.

Link-Up is shown in *Figure 9*. The MC and MDn signals are current waveforms. Data at the DES output will appear a latency delay later.

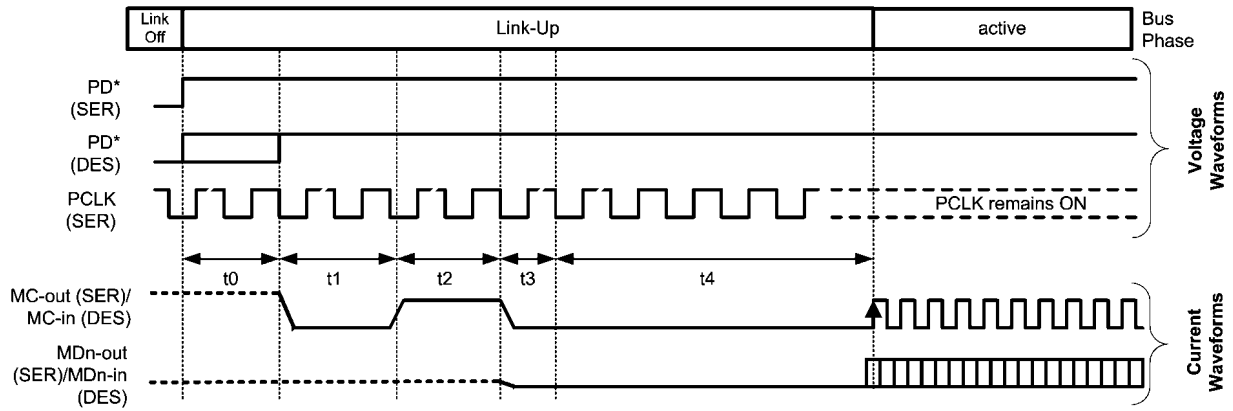

20172861

FIGURE 9. MPL Power Up Timing

**OFF PHASE**

In the OFF phase, MPL transmitters are turned off with zero current flowing on the MC and MDn lines. *Figure 10* shows the transition of the MPL bus into the OFF phase. If an MPL line is driven to a logical Low (high current) when the OFF phase is entered it may temporarily pass through as a logical High (low current) before reaching the zero line current state. The link may be powered down by asserting both the SER's and DES's PD\* input pins (Low) or by stopping the PCLK (DES dependant). This causes the devices to immediately put the link to the OFF Phase and internally enter a low power state.

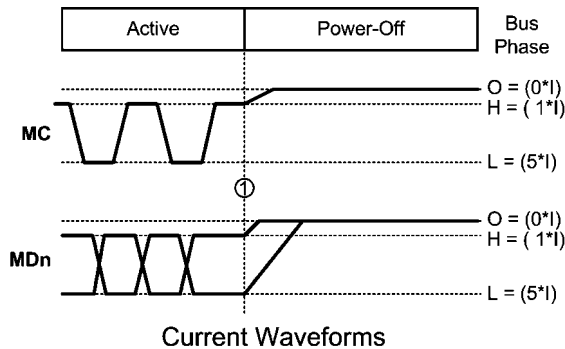

20172806

FIGURE 10. Bus Power Down Timing

**RGB VIDEO INTERFACE**

The LM2512 is transparent to data format and control signal timing. Each PCLK, RGB inputs, HS, VS and DE are sampled on the rising edge of the PCLK. A PCLK by PCLK representation of these signals is duplicated on the opposite device after being transferred across the MPL Level-0 interface.

The LM2512 can accommodate a wide range of display formats. QVGA to VGA can be supported within the 2MHz to 20 MHz PCLK input range.

The 24-bit RGB (R0-7, G0-7, B0-7) color information is dithered to 18 bits then serialized, followed by the control bits VS (VSYNC), HS (HSYNC), DE (Data Enable) and PE (Odd Parity) and Frame Sequence (F[1:0]) bits.

The default configuration is for 3 MD lanes plus the MC. Via the SPI Interface, the Serializer can be configured for a 2 MD Lane configuration.

When transporting color depth below 24-bit, the 24-bit protocol can be used by offsetting the color data. The LSBs of the RGB are not used and data is offset toward the upper (MSB) end of the bit fields. Unused inputs should be tied off.

At a maximum PCLK of 20 MHz (3MDs), a 80MHz MC clock is generated. The data lane rate uses both clock edges, thus 160Mbps (raw) are sent per MD lane.

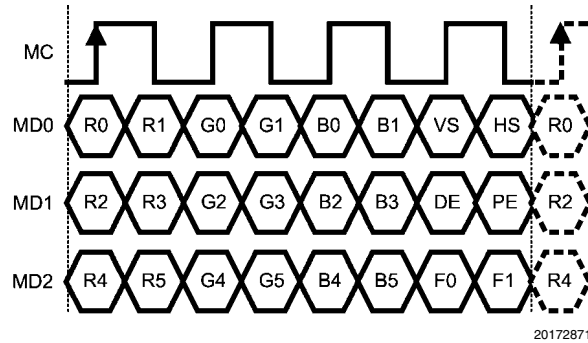

FIGURE 11. 24-bit to 18-bit Dithered, 3 MD Lane, RGB Transaction

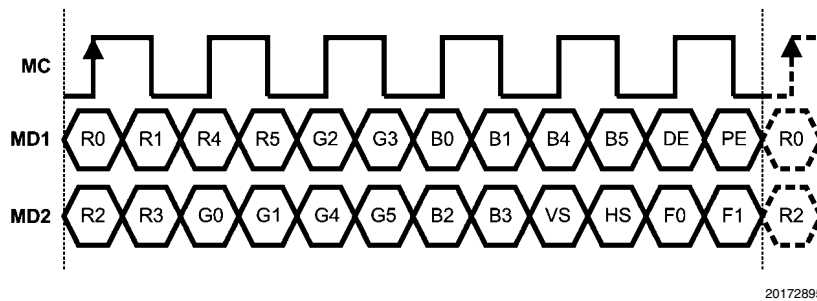

FIGURE 12. 24-bit to 18-bit Dithered, 2 MD Lane, RGB Transaction (NOTE MD1 and MD2)

#### Serial Payload Parity Bit

Odd Parity is calculated on the RGB bits, control (VS, HS, and DE) bits and F0, F1 bits and then sent from the SER to the DES via the serial PE bit. This is included for compatibility with certain MPL Deserializers.

#### Synchronization Detect and Recovery

If a data error or clock slip error occurs over the MPL link, the RGB MPL Deserializer can detect this condition and recover from it. The method chosen is a data transparent method, and has very little overhead because it does not use a data expansion coding method. For the Dithered 18-bit color transaction, it uses two bits that are already required in the 4 MC cycle transaction. Total overhead for each pixel is 3/24 or 12.5%.

The LM2512 MPL RGB Serializer simply increments the two bit field F[1:0] on every pixel (MPL frame) transmitted. Therefore every four MPL frames, the pattern will repeat. It is very unlikely that this pattern would be found within the payload data, and if it were found, the probability that it would repeat for many frames becomes infinitely small. This code is used by the MPL Deserializer to detect any frame alignment problems and quickly recover.

The RGB MPL Deserializer, upon a normal power up sequence, starts in the proper synchronization. If synchroniza-

tion is lost for any reason, it searches for the incrementing pattern. Once found, it resynchronizes the output pixel data and timing signals. See MPL DES Datasheet for details on how the specific DES handles the Frame Sequence.

#### DITHERING FEATURE

The LM2512 is a 2 or 3-Lane MPL Serializer, 24-bit RGB input data (8-bits/color channel) is internally dithered to 18-bits (6-bits/color channel) using a high-quality stochastic dithering process. This process has a "blue noise" characteristic that minimizes the visibility of the dither patterns. The resulting data stream of 18-bit data is then serialized and transmitted via MPL.

**The Dither circuitry requires the VS control signal for proper operation.** This signal is used to generate an internal signal that marks the start of the (video) frame. The serializer samples and sends the VS information unmodified.

Dithering parameters are controlled by two registers. When the dithering is bypassed, only RGB[7:2] is serialized and transmitted for 18-bit input RGB [5:0] (MSB aligned). RGB [1:0] should not be connected and the unused input should be tied low; do not leave input open.

### LOOK UP TABLE OPTION AND SPI INTERFACE

Three 256 X 8-bit SRAMs provide a Look Up Table for independent color correction. The LUT is disabled by default and also after a device PD\* cycle. The PD\* cycle can be entered via the PD\* input pin directly, or by stopping the PCLK. Before using the LUT, the SRAM must be loaded with its contents. If power is cycled to the device, the LUT must be loaded again.

To enable the LUT:

1. Select/Unlock the LM2512 SPI Interface - Write FF'h to REG22 (16'h)
2. Write the LUT contents to the SRAM using Writes or Page Writes
3. Access each of the three SRAM at least once to ensure that they are in their lowest power state.
4. Enable the LUT - Write a 01'h to REG0 (00'h)
5. De-Select/Lock the LM2512 SPI interface -Write 00'h to REG22 (16'h)

When waking up the LM2512 from the power down mode (PD\*=L), the LUT needs to be enabled if it is desired. Contents to the SRAM are still held and valid.

1. Select/Unlock the LM2512 SPI Interface - Write FF'h to REG22 (16'h)

2. Enable the LUT - Write a 01'h to REG0 (00'h)
3. Optional -select Lane Scale if not using default
4. De-Select/Lock the LM2512 SPI interface -Write a 00'h to REG22 (16'h)

If power is cycled to the device, the LUT SRAMs must be loaded again.

#### SPI Interface

The Serial Peripheral Interface (SPI) allows control over various aspects of the LM2512, the Look Up Table operation, and access to the three 256 x 8-RAM blocks. There are 9 defined registers in the device. Three SPI transactions are supported, which are: 16-bit WRITE, PAGE WRITE, and a 16-bit READ. The SPI interface is disabled when the device is in the sleep mode (via PCLK Stop or by PD\* = L). The SPI interface may be used when PD\* = H.

#### 16-bit WRITE

The 16-bit WRITE is shown in *16-bit WRITE – SPI*. The SDA payload consists of a "0" (Write Command), seven address bits and eight data bits. The CSX signal is driven Low, and 16-bits of SDA (data) are sent to the device. Data is latched on the rising edge of the SCL. After each 16-bit WRITE, CSX must return HIGH.

#### 16-bit WRITE – SPI

Bit	B15	B14	B13	B12	B11	B10	B9	B8	B7	B6	B5	B4	B3	B2	B1	B0
SDA	0	A6	A5	A4	A3	A2	A1	A0	D7	D6	D5	D4	D3	D2	D1	D0

#### 16-bit READ

The 16-bit READ is shown in *16-bit READ – SPI*. The SDA payload consists of a "1" (Read Command), seven address bits and eight data bits which are driven from the device. The

CSX signal is driven Low, and the host drives the first 8 bits of the SDA ("1" and seven address bits), the device then drives the respective 8 bits of the data on the SDA signal.

#### 16-bit READ – SPI

Bit	B15	B14	B13	B12	B11	B10	B9	B8	B7	B6	B5	B4	B3	B2	B1	B0
SDA	1	A6	A5	A4	A3	A2	A1	A0	D7	D6	D5	D4	D3	D2	D1	D0

#### PAGE WRITE

The PAGE WRITE is shown in *Figure 17*. The SDA payload consists of a "0" (Write Command), seven address bits of the start address and then the consecutive data bytes. 256 bytes maximum can be sent. The CSX signal is driven Low, and the

host drives the SDA signal with a "0" (Write Command), the seven start address bits and the variable length data bytes. The Page Write is denoted by the CSX signal staying low while the data bytes are streamed. Data is latched on the rising edge of the SCL.

#### PAGE WRITE

Bit	B15	B14	B13	B12	B11	B10	B9	B8	B7	B6	B5	B4	B3	B2	B1	B0
SDA	0	A6	A5	A4	A3	A2	A1	A0	D7	D6	D5	D4	D3	D2	D1	D0
	(start address)								(Data Byte 0)							
	D7	D6	D5	D4	D3	D2	D1	D0	D7	D6	D5	D4	D3	D2	D1	D0
	(Data Byte 1)								(Data Byte n, 256 max.)							

There are three SPI Interface signals: CSX - SPI Chip Select, SCL - SPI Clock, and SDA - SPI Data. CSX and SCL are inputs on the LM2512. SDA is a bi-directional Data line and is an input for a WRITE and an output for the READ\_DATA portion of a READ operation. READs are optional and are not

required. Due to the Select/Unlock – De-Select/Lock feature of the device the SPI interface may be shared with the display driver. Several connection configurations are possible. A couple examples are shown in *Figure 13* and *Figure 14*.

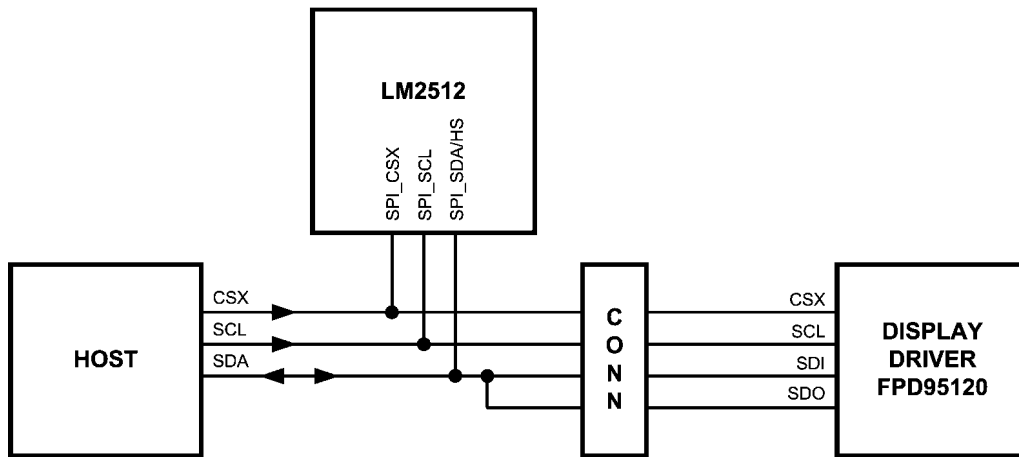

20172888

FIGURE 13. LM2512 WRITE &amp; READ to 3-signal SPI HOST

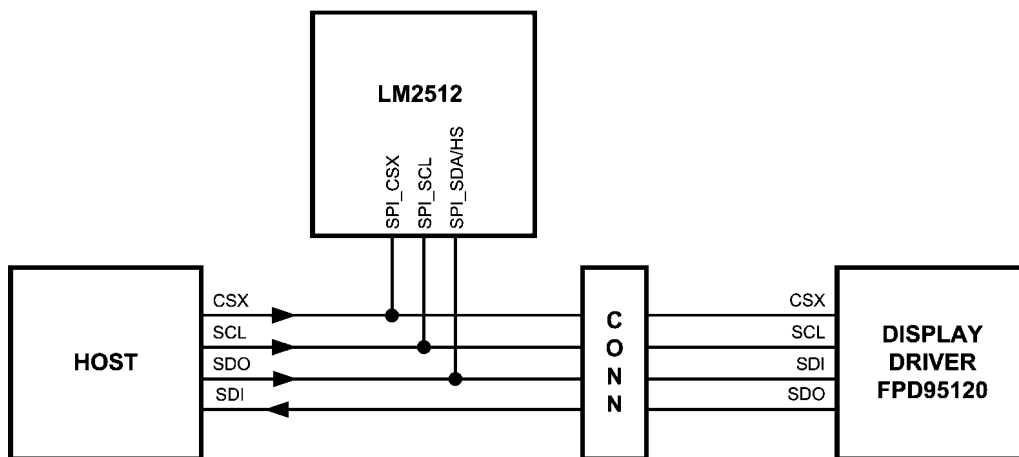

20172889

FIGURE 14. LM2512 WRITE only to 4-signal SPI HOST

## LM2512 SPI Registers

Name	Address	Type	Description	Default
Command	0x00	R/W	Bit 0 = LUT Enable 0'b = LUT Disabled, 1'b = LUT Enabled Bit 4 = Special Register Access 0'b = SRA Locked, 1'b = SRA Unlocked For access to Registers 0x08, 0x09, 0x0A, the Special Register Access bit must be unlocked. Must write all 8 bits.	00'h
<b>Reserved</b> (Note 15)	0x01	na	<b>Reserved</b>	
Red RAM Address	0x02	R/W	Red Address	00'h
Red RAM Data	0x03	R/W	Red Data	XX'h
Green RAM Address	0x04	R/W	Green Address	00'h
Green RAM Data	0x05	R/W	Green Data	XX'h
Blue RAM Address	0x06	R/W	Blue Address	00'h
Blue RAM Data	0x07	R/W	Blue Data	XX'h
Dither Configuration1 (Note 14)	0x08	R/W	Bit 0 - Dither Bypass 1'b = Bypass Dither, 0'b = Dither ON Bit 1 - DE INV 1'b = Active Low DE, 0'b = Active High DE Does not alter DE signal, dither block input only. Bit 2 - VS INV 1'b = Active Low VS signal, 0'b = Active High VS signal. Does not alter VS signal, dither block input only. Bit 3 - Reserved Bit 4 - Tempen0 1'b = Transposed Dither Pattern, 0'b = Even and odd frames use same dither pattern Bit 5 - Tempen1 1'b = Temporal Dithering is Enabled, 0'b = Disabled Bit 6 - Dith3 - Dither Amplitude 1'b = set to 3 bits, 0'b = set to 4 bits Bit 7 - Reserved	60'h
Dither Configuration2 (Note 14)	0x09	R/W	Dither Parameter <b>Reserved</b> , Default value recommended.	67'h
Lane Scale (Note 14)	0x0A	W	Bit[2:0] 000'b = Reserved 010'b = 2 MD Lanes 100'b = 3 MD Lanes (Default) all others= Reserved	04'h
<b>Reserved</b> (Note 15)	0x0B- 0x15	na	<b>Reserved</b>	
Device Select (Unlock/Lock)	0x16	R/W	0xFF'h enables LM2512 SPI All other values disables LM2512 SPI (0x00 to 0xFE)	00'h
<b>Reserved</b> (Note 15)	0x17- 0x7F	na	<b>Reserved</b>	

**Note 13:** If a WRITE is done to a reserved bits, data should be all 0's. If a READ is done to a reserved location, either 1's or 0's may be returned. Mask reserved data bits.

**Note 14:** This register must be unlocked first through bit 4 of register 0. This register is currently a write only register, read is not supported.

**Note 15:** DO NOT write to Reserved Registers.

# SPI Timing

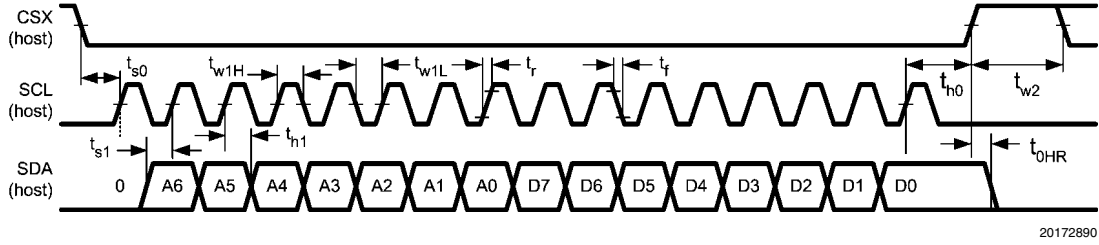

FIGURE 15. 16-bit SPI WRITE

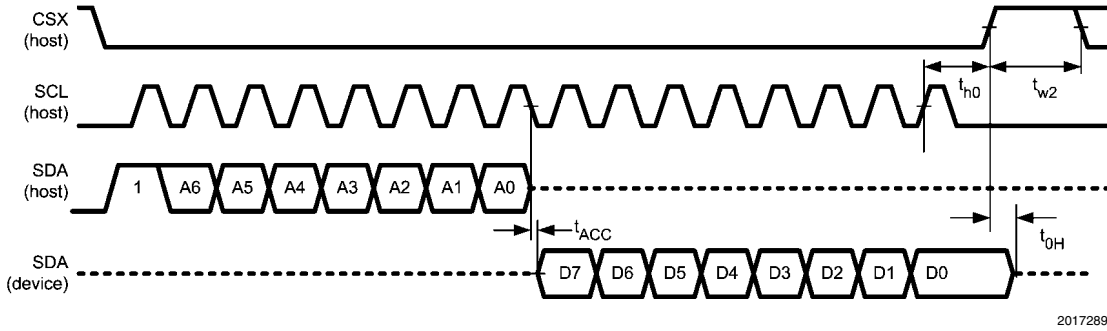

FIGURE 16. 16-bit SPI READ

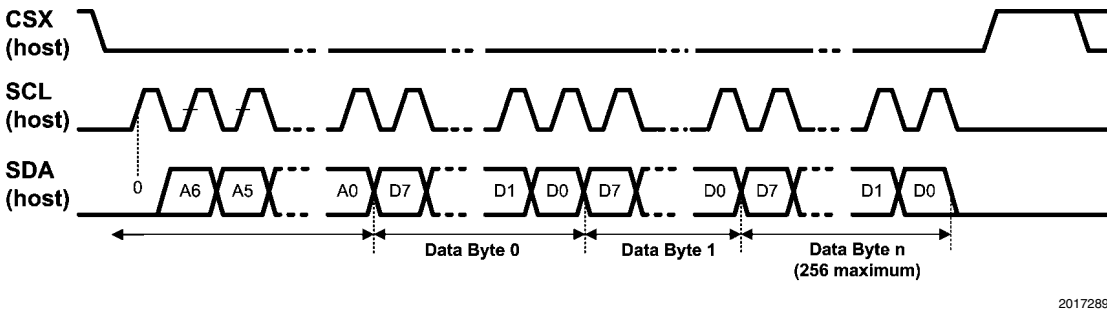

FIGURE 17. SPI PAGE WRITE

## Power Up Sequence

The MPL Link must be powered up and enabled in a certain sequence for proper operation of the link and devices. The following list provides the recommended sequence:

1. Apply Power (See Power Supply Section)
2. PD\* Input should be held low until Power is stable and within specification and PCLK is driven to a static level.
3. PD\* is driven HIGH, SPI interface is now available.
4. To program the device via the SPI interface:
  - Select / Unlock the LM2512, Write FF'h to REG 16'h

- LUT registers are now accessible
  - If Lane Scale Register need to be modified, this is accessed through bit 4 of the Command register.
  - A write to REG 16'h on any other value besides FF'h will de-select / lock the LM2512's SPI
  - SPI Commands **MUST** be completed before the PCLK is active.
5. Condition the DES as required
  6. Start PCLK, after the DES is calibrated and the SER PLL Locked, streaming data transmission will occur.

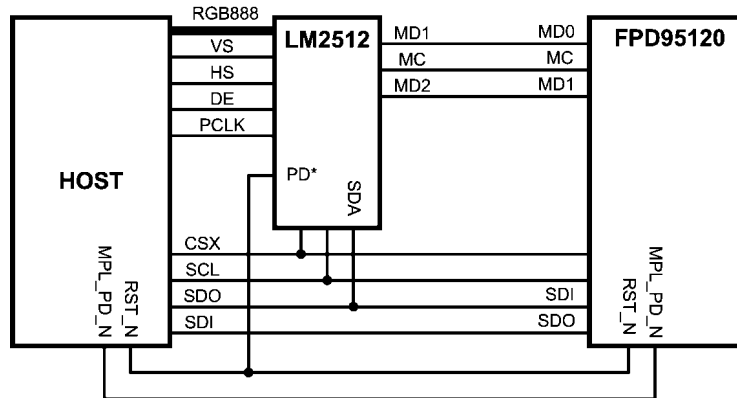

20172885

FIGURE 18. Typical Application Connection Diagram

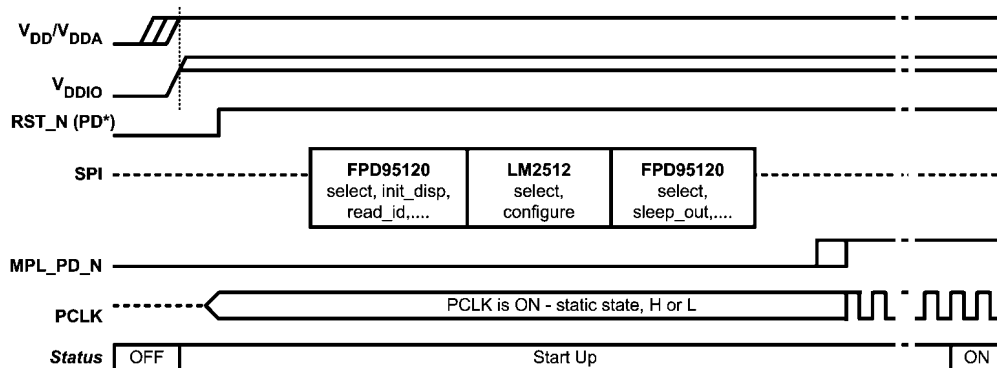

20172886

FIGURE 19. Power Up Sequence

A typical connection diagram is shown in *Figure 18*. The LM2512 SPI is configured to support write only transactions in this example. The FPD95120 can support both writes and reads on its SPI interface. *Figure 19* shows a typical power up sequence using the shared SPI interface. Power is brought up first. The RST\_N signal is held low until power to the FPD95120 (not shown) and the LM2512 is stable and within specifications. Next the RST\_N signal is driven High, which allows access to the SPI interfaces. The PCLK should also be turned on and held at a static level (High or Low). The FPD95120 is selected first via a write to register 16'h (see FPD95120 datasheet) and the display is initialized. Next a write of FF'h to register 16'h. This command will Lock the FPD95120 SPI interface and Select / Unlock the LM2512 SPI

interface. By default, the LM2512 powers up in 3 MD lanes with the LUT disabled. The Look-up Table - LUT is accessible by enabling bit 0 of the command register 00'h. The Special Register Access - SRA are also accessible for lane scaling by enabling bit 4 of the command register 00'h. To enable the LUT and unlock SRA, write of 11'h to register 00'h (See LM2512 SPI Register Table). To change to 2 MD lanes, write of 02'h to register 0A'h. The LM2512 has the potential to power-up into a condition which causes unwanted leakage current in the SRAMs. An access to each SRAM over the SPI interface as part of the power-up sequence is recommended in order to eliminate a potential power-up current leakage. Write of XX'h (don't care) data value or address value to each of the three SRAM registers (03'h, 05'h and 07'h). Next additional



commands are sent to the FPD95120 by issuing a Unlock command to the FPD95120 register 16'h which also de-selects / locks the LM2512 SPI. After the SPI commands are completed, the MPL\_PD\_N signal is driven High to arm the Deserializer for the MPL start sequence. The PCLK is started up, and the SER will calibrate the DES and lock to the incoming PCLK signal. Once this is completed, video data transmission occurs and the link is ON.

- LM2512 - 2 MD Lane to FPD95120 Display Driver
- LM2512 - 3 MD Lane to MPL-1 DES
- LM2512 - 2 MD Lane to MPL-1 DES
- LM2512 - 2 MD Lane to LM2506 DES

Take care in reviewing the MPL signals and serial bit mapping to ensure proper connection between the devices.

## Application Configurations

Many different application configurations are possible with the flexible LM2512 Serializer. These include:

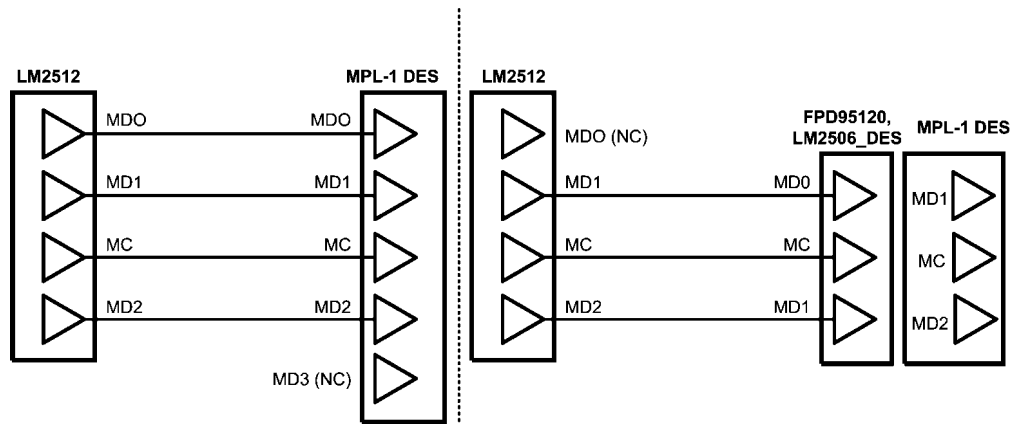

20172887

FIGURE 20. Application Configurations

## LM2512 Operation

### POWER SUPPLIES

The  $V_{DD}$  and  $V_{DDA}$  (MPL and PLL) must be connected to the same potential between 1.6V and 2.0V.  $V_{DDIO}$  powers the logic interface and may be powered between 1.6V and 3.0V to be compatible with a wide range of host and target devices.

$V_{DD}/V_{DDA}$  should be powered ON at the same time as  $V_{DDIO}$  or before.  $V_{DDIO}$  then  $V_{DD}/V_{DDA}$  is not recommended.

### BYPASS RECOMMENDATIONS

Bypass capacitors should be placed near the power supply pins of the device. Use high frequency ceramic (surface mount recommended) 0.1  $\mu$ F capacitors. A 2.2 to 4.7  $\mu$ F Tantalum capacitor is recommended near the SER  $V_{DDA}$  pin for PLL bypass. Connect bypass capacitors with wide traces and use dual or larger via to reduce resistance and inductance of the feeds. Utilizing a thin spacing between power and ground planes will provide good high frequency bypass above the frequency range where most typical surface mount capacitors are less effective. To gain the maximum benefit from this, low inductance feed points are important. Also, adjacent signal layers can be filled to create additional capacitance. Minimize loops in the ground returns also for improved signal fidelity and lowest emissions.

### UNUSED/OPEN PINS

Unused inputs **must** be tied to the proper input level—do not float them.

### PHASE-LOCKED LOOP

A PLL is enabled to generate the serial link clock. The Phase-locked loop system generates the serial data clock at 4X or 6X of the input clock depending upon the number of MD Lanes selected. The MC rate is limited to 80 MHz for this enhanced Class 0 MPL PHY.

### POWER DOWN/OFF CONFIGURATION / OPTIONS AND CLOCK STOP

The LM2512 (SER) can be controlled by its PD\* input pin or via a auto power down mode that monitors the PCLK input signal.

For PD\* Input Power Down control, a GPO signal from the host is used to enable and disable the LM2512 and the DES. The LM2512 is enabled when the PD\* input is High and disabled when the PD\* input is Low.

When using the auto power down mode, the PD\* input needs to be held High. When the PCLK is held static, the SER will detect this condition and power down. When the PCLK is restarted, the SER powers up, The DES is calibrated, and the PLL locks to the incoming clock signal. Once this is complete, video data transmission can occur. See *Figures 3, 4 and Figure 9*. The stopping of the pixel clock should be done cleanly. The minimum clock stop gap should be at least 4 PCLK cycles wide. Floating of the PCLK input pin is not recommended. Consult the MPL DES datasheet to determine requirements that the DES requires.

## Application Information

### SYSTEM BANDWIDTH CALCULATIONS

For a HVGA (320 X 480) application with the following assumptions: 60 Hz +/-5% refresh rate, 10% blanking, RGB666, and 2 MD Lanes and following calculations can be made:

Calculate PCLK -  $320 \times 480 \times 1.1 \times 60 \times 1.05 = 10.6$  MHz PCLK

Calculate MC rate - since the application is 2 MD lanes, PCLK X 6 is the MC rate or 63.87 MHz. Also check that this MC rate does not exceed the MC maximum rate for the chipset.

Calculate MD rate - MPL uses both edges of the MC to send serialized data, thus data rate is 2X the MC rate, or 127.7 Mbps per MD lane in our example.

Calculate the application throughput - using 2 MD lanes, throughput is 2 X of the MD rate or 255.5 Mbps of raw band width.

For a VGA (640 X 480) application with the following assumptions: 55 Hz +/-5% refresh rate, 10% blanking, RGB666, and 3 MD Lanes and following calculations can be made:

Calculate PCLK -  $640 \times 480 \times 1.1 \times 55 \times 1.05 = 19.5$  MHz PCLK

Calculate MC rate - since the application is 3 MD lanes, PCLK X 4 is the MC rate or 78.1 MHz. Also check that this MC rate does not exceed the MC maximum rate for the chipset.

Calculate MD rate - MPL uses both edges of the MC to send serialized data, thus data rate is 2X the MC rate, or 156 Mbps per MD lane in our example.

Calculate the application throughput - using 3MD lanes, throughput is 3X of the MD rate or 468 Mbps of raw band width.

### SYSTEM CONSIDERATIONS

When employing the MPL SER/DES chipset in place of a parallel video bus, a few system considerations must be taken into account. Before sending video data to the display, the SER/DES must be ready to transmit data across the link. The MPL link must be powered up, and the PLL must be locked and the DES calibrated.

### FLEX CIRCUIT RECOMMENDATIONS

The MPL lines should generally run together to minimize any trace length differences (skew). For impedance control and also noise isolation (crosstalk), guard ground traces are recommended in between the signals. Commonly a Ground-Signal-Ground (GSGSGSG) layout is used. Locate fast edge rate and large swing signals further away to also minimize any coupling (unwanted crosstalk). In a stacked flex interconnect, crosstalk also needs to be taken into account in the above and below layers (vertical direction). To minimize any coupling locate MPL traces next to a ground layer. Power rails also tend to generate less noise than LVCMOS so they are also good candidates for use as isolation and separation.

The interconnect from the SER to the DES typically acts like a transmission line. Thus impedance control and ground returns are an important part of system design. Impedance should be in the 50 to 100 Ohm nominal range for the LM2512. Testing has been done with cables ranging from 40 to 110 Ohms without error (BER Testing). To obtain the impedance, adjacent grounds are typically required ( 1 layer flex), or a ground shield / layer. Total interconnect length is intended to be in the 20cm range, however 30cm is possible at lower data rates. Skew should be less than 500ps to maximize timing margins.

### GROUNDING

While the LM2512 employs three separate types of ground pins, these are intended to be connected together to a common ground plane. The separate ground pins help to isolate switching currents from different sections of the integrated circuit (IC). Also required is a nearby signal return (ground) for the MPL signals. These should be provided next to the MPL signals, as that will create the smallest current loop area.

The grounds are also useful for noise isolation and impedance control.

### PCB RECOMMENDATIONS

General guidelines for the PCB design:

- Floor plan, locate MPL SER near the connector to limit chance of cross talk to high speed serial signals.
- Route serial traces together, minimize the number of layer changes to reduce loading.
- Use ground lines as guards to minimize any noise coupling (guarantees distance).
- Avoid parallel runs with fast edge, large LVCMOS swings.
- Also use a GSGSG pinout in connectors (Board to Board or ZIF).
- DES device - follow similar guidelines.
- Bypass the device with MLC surface mount devices and thinly separated power and ground planes with low inductance feeds.
- High current returns should have a separate path with a width proportional to the amount of current carried to minimize any resulting IR effects.

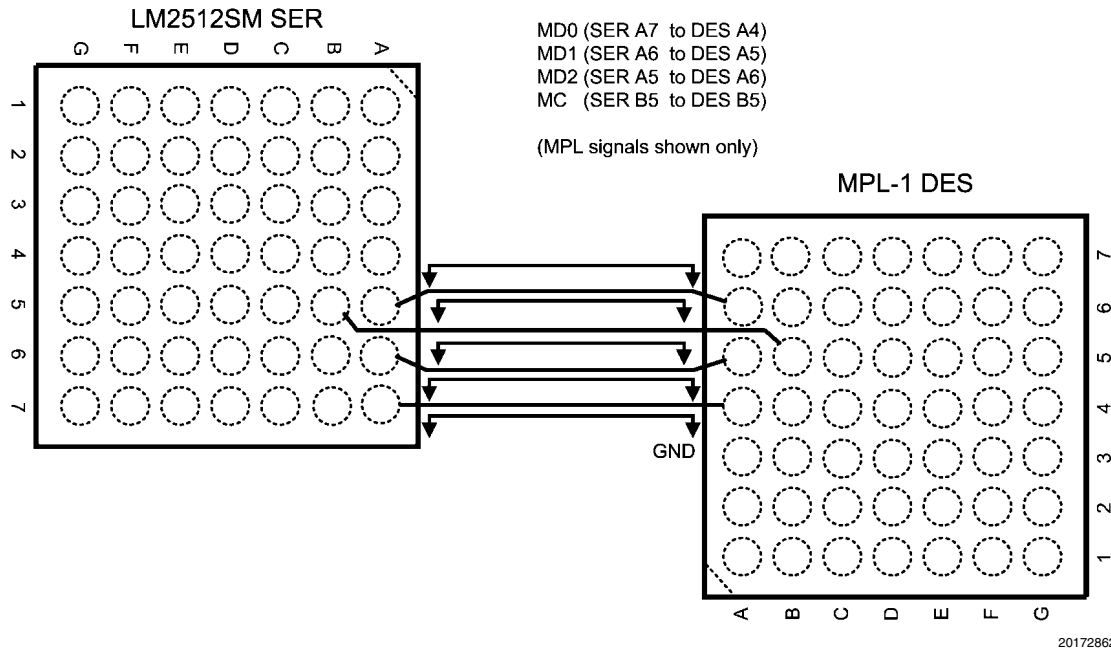

**FIGURE 21. MPL Interface Layout**

## Connection Diagram 49 UFBGA Package

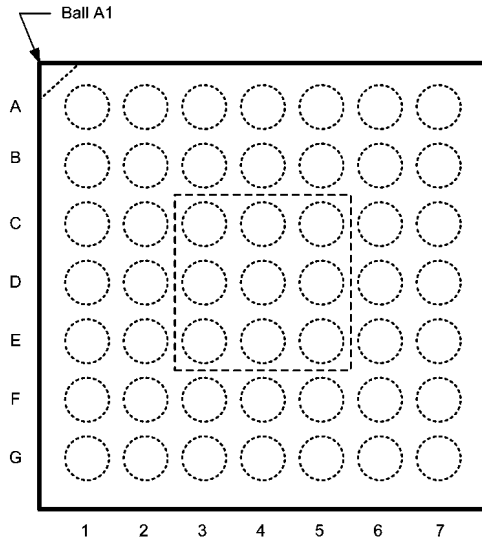

20172819

**TOP VIEW**  
(not to scale)

### RGB SER Pinout

SER	1	2	3	4	5	6	7
A	B1	SPI_SDA/HS	RES1	NC	MD2	MD1	MD0
B	B2	B0	VS	$V_{DDA}$	MC	TM	PD*
C	PCLK	B3	DE	$V_{SSA}$	SPI_CSX	SPI_SCL	R7
D	$V_{SSIO}$	$V_{DDIO}$	B4	$V_{SSIO}$	$V_{SSIO}$	$V_{DDIO}$	R6
E	B6	B7	G5	B5	R1	R4	R5
F	G0	G1	G4	$V_{DD}$	G6	R0	R3
G	G2	G3	$V_{SS}$	$V_{SSIO}$	$V_{DDIO}$	G7	R2

# Connection Diagram 40 LLP Package

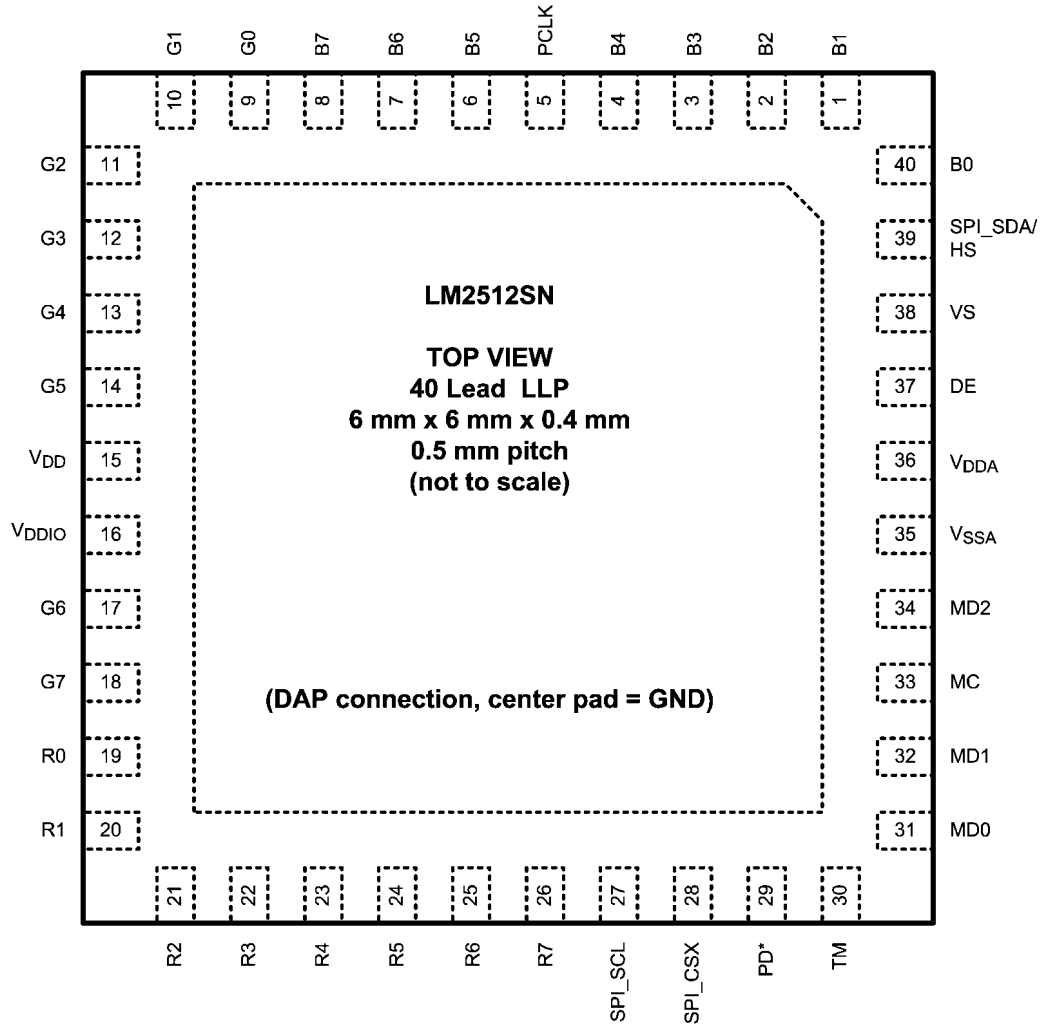

20172896

**TOP VIEW**  
**(not to scale)**

**Physical Dimensions** inches (millimeters) unless otherwise noted

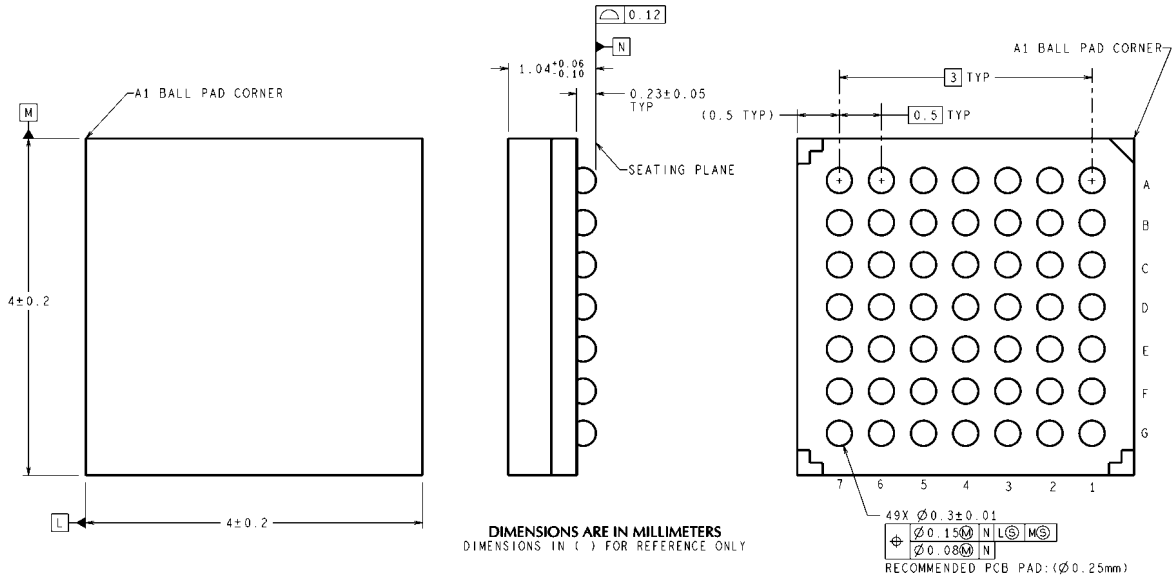

SLH49A (Rev D)

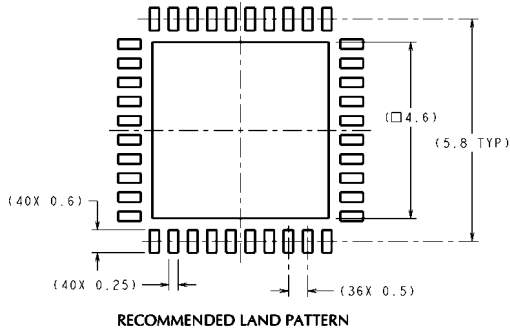

**DIMENSIONS ARE IN MILLIMETERS**  
DIMENSIONS IN ( ) FOR REFERENCE ONLY

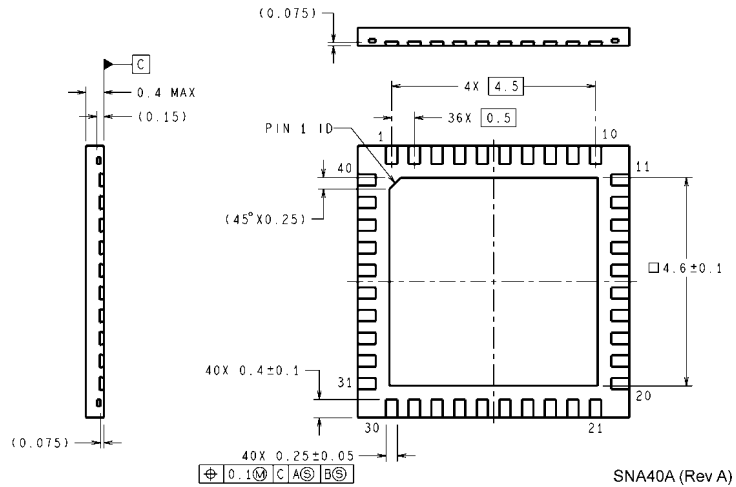
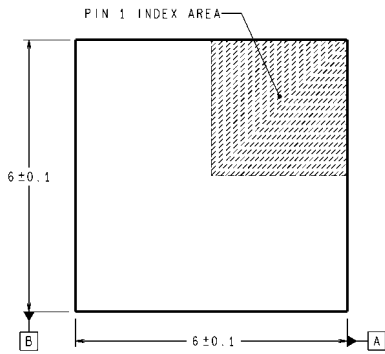

SNA40A (Rev A)

# Notes

LM2512

## Notes

For more National Semiconductor product information and proven design tools, visit the following Web sites at:

Products		Design Support	
Amplifiers	<a href="http://www.national.com/amplifiers">www.national.com/amplifiers</a>	WEBENCH	<a href="http://www.national.com/webench">www.national.com/webench</a>
Audio	<a href="http://www.national.com/audio">www.national.com/audio</a>	Analog University	<a href="http://www.national.com/AU">www.national.com/AU</a>
Clock Conditioners	<a href="http://www.national.com/timing">www.national.com/timing</a>	App Notes	<a href="http://www.national.com/appnotes">www.national.com/appnotes</a>
Data Converters	<a href="http://www.national.com/adc">www.national.com/adc</a>	Distributors	<a href="http://www.national.com/contacts">www.national.com/contacts</a>
Displays	<a href="http://www.national.com/displays">www.national.com/displays</a>	Green Compliance	<a href="http://www.national.com/quality/green">www.national.com/quality/green</a>
Ethernet	<a href="http://www.national.com/ethernet">www.national.com/ethernet</a>	Packaging	<a href="http://www.national.com/packaging">www.national.com/packaging</a>
Interface	<a href="http://www.national.com/interface">www.national.com/interface</a>	Quality and Reliability	<a href="http://www.national.com/quality">www.national.com/quality</a>
LVDS	<a href="http://www.national.com/lvds">www.national.com/lvds</a>	Reference Designs	<a href="http://www.national.com/refdesigns">www.national.com/refdesigns</a>
Power Management	<a href="http://www.national.com/power">www.national.com/power</a>	Feedback	<a href="http://www.national.com/feedback">www.national.com/feedback</a>
Switching Regulators	<a href="http://www.national.com/switchers">www.national.com/switchers</a>		
LDOs	<a href="http://www.national.com/lido">www.national.com/lido</a>		
LED Lighting	<a href="http://www.national.com/led">www.national.com/led</a>		
PowerWise	<a href="http://www.national.com/powerwise">www.national.com/powerwise</a>		
Serial Digital Interface (SDI)	<a href="http://www.national.com/sdi">www.national.com/sdi</a>		
Temperature Sensors	<a href="http://www.national.com/tempsensors">www.national.com/tempsensors</a>		
Wireless (PLL/VCO)	<a href="http://www.national.com/wireless">www.national.com/wireless</a>		

THE CONTENTS OF THIS DOCUMENT ARE PROVIDED IN CONNECTION WITH NATIONAL SEMICONDUCTOR CORPORATION ("NATIONAL") PRODUCTS. NATIONAL MAKES NO REPRESENTATIONS OR WARRANTIES WITH RESPECT TO THE ACCURACY OR COMPLETENESS OF THE CONTENTS OF THIS PUBLICATION AND RESERVES THE RIGHT TO MAKE CHANGES TO SPECIFICATIONS AND PRODUCT DESCRIPTIONS AT ANY TIME WITHOUT NOTICE. NO LICENSE, WHETHER EXPRESS, IMPLIED, ARISING BY ESTOPPEL OR OTHERWISE, TO ANY INTELLECTUAL PROPERTY RIGHTS IS GRANTED BY THIS DOCUMENT.

TESTING AND OTHER QUALITY CONTROLS ARE USED TO THE EXTENT NATIONAL DEEMS NECESSARY TO SUPPORT NATIONAL'S PRODUCT WARRANTY. EXCEPT WHERE MANDATED BY GOVERNMENT REQUIREMENTS, TESTING OF ALL PARAMETERS OF EACH PRODUCT IS NOT NECESSARILY PERFORMED. NATIONAL ASSUMES NO LIABILITY FOR APPLICATIONS ASSISTANCE OR BUYER PRODUCT DESIGN. BUYERS ARE RESPONSIBLE FOR THEIR PRODUCTS AND APPLICATIONS USING NATIONAL COMPONENTS. PRIOR TO USING OR DISTRIBUTING ANY PRODUCTS THAT INCLUDE NATIONAL COMPONENTS, BUYERS SHOULD PROVIDE ADEQUATE DESIGN, TESTING AND OPERATING SAFEGUARDS.

EXCEPT AS PROVIDED IN NATIONAL'S TERMS AND CONDITIONS OF SALE FOR SUCH PRODUCTS, NATIONAL ASSUMES NO LIABILITY WHATSOEVER, AND NATIONAL DISCLAIMS ANY EXPRESS OR IMPLIED WARRANTY RELATING TO THE SALE AND/OR USE OF NATIONAL PRODUCTS INCLUDING LIABILITY OR WARRANTIES RELATING TO FITNESS FOR A PARTICULAR PURPOSE, MERCHANTABILITY, OR INFRINGEMENT OF ANY PATENT, COPYRIGHT OR OTHER INTELLECTUAL PROPERTY RIGHT.

### LIFE SUPPORT POLICY

**NATIONAL'S PRODUCTS ARE NOT AUTHORIZED FOR USE AS CRITICAL COMPONENTS IN LIFE SUPPORT DEVICES OR SYSTEMS WITHOUT THE EXPRESS PRIOR WRITTEN APPROVAL OF THE CHIEF EXECUTIVE OFFICER AND GENERAL COUNSEL OF NATIONAL SEMICONDUCTOR CORPORATION.** As used herein:

Life support devices or systems are devices which (a) are intended for surgical implant into the body, or (b) support or sustain life and whose failure to perform when properly used in accordance with instructions for use provided in the labeling can be reasonably expected to result in a significant injury to the user. A critical component is any component in a life support device or system whose failure to perform can be reasonably expected to cause the failure of the life support device or system or to affect its safety or effectiveness.

National Semiconductor and the National Semiconductor logo are registered trademarks of National Semiconductor Corporation. All other brand or product names may be trademarks or registered trademarks of their respective holders.

Copyright© 2008 National Semiconductor Corporation

For the most current product information visit us at [www.national.com](http://www.national.com)



**National Semiconductor Americas Technical Support Center**  
 Email: [support@nsc.com](mailto:support@nsc.com)  
 Tel: 1-800-272-9959

**National Semiconductor Europe Technical Support Center**  
 Email: [europe.support@nsc.com](mailto:europe.support@nsc.com)  
 German Tel: +49 (0) 180 5010 771  
 English Tel: +44 (0) 870 850 4288

**National Semiconductor Asia Pacific Technical Support Center**  
 Email: [ap.support@nsc.com](mailto:ap.support@nsc.com)

**National Semiconductor Japan Technical Support Center**  
 Email: [jpn.feedback@nsc.com](mailto:jpn.feedback@nsc.com)