

### Features and Benefits

- Dual low noise, low offset, fully programmable amplifier chain
- 12 bit on-chip ADC
- Powerful signal conditioning and linearisation unit
- Multiple output options: 12 bit digital through SPI, 8 bit resolution analog linear signal outputs or 10 bit PWM, both for ambient and object temperature.
- On-chip programmable digital moving average LPF for ultimate low noise performance
- ISP I/O-configuration and analog settings, accessible by SPI serial interface.
- Wide supply voltage range from 4.5V-80V

### Applications

- Thermopile + thermistor amplification chain
- Digital or analog, linear, ambient-compensated IR sensor interface
- General purpose programmable sensor amplifier/ signal conditioner

### Ordering Information

Part No.	Temperature Suffix	Package	Temperature Range
MLX90313	K	DF	-40C to 125C Automotive

### Functional Diagram

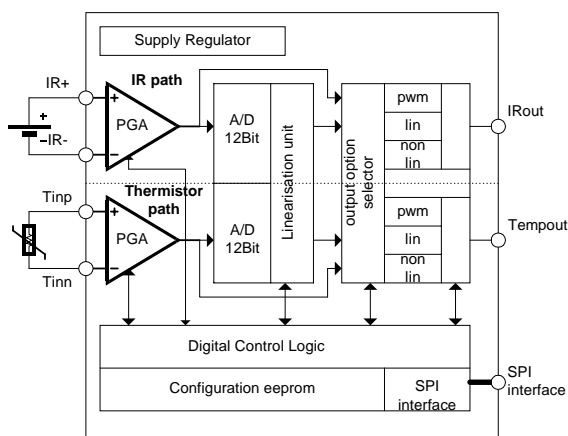

### Description

The MLX90313 is a versatile in-circuit programmable interface, which performs signal conditioning, linearisation and ambient temperature compensation, particularly for infrared sensors combined with a thermistor. Other types of sensors can also be used in various configurations. Sensors that can be used include pressure sensors, strain gauges, acceleration sensors etc.

The amplifier chains in MLX90313 are programmable in very broad ranges of gain. Both chains consist of high performance, chopper-stabilized amplifiers, providing excellent noise performance and low offset. The I/O configuration as well as analog settings are in-circuit programmable by means of the SPI-serial interface. This serial link can also be used to read out the output signals digitally. The circuit can either provide linear analog or PWM (Pulse Width Modulated) signal outputs. Additionally, the circuit can perform simple control applications using on-board comparators.

### MLX90313 Electrical Specifications

DC Operating Parameters  $T_A = -40^{\circ}\text{C}$  to  $125^{\circ}\text{C}$ ,  $V_{DD} = 4.5\text{V}$  to  $80\text{V}$  (unless otherwise specified)

Parameter	Symbol	Test Conditions	Min	Typ	Max	Unit
<b>Regulator and consumption</b>						
Supply voltage range	Vin1	VDD1	7		80	V
Supply voltage range	Vin	VDD	4.5	5	5.5	V
Supply current	I <sub>dd</sub>	@ $T_A=25^{\circ}\text{C}$		5	5.6	mA
Regulated supply voltage	V <sub>reg</sub>	VDD, 10 $\mu\text{F}$ ext. cap	4.7	5	5.3	V
Regulated voltage temperature coefficient	TC <sub>vr</sub>			-2.35		mV/ $^{\circ}$
POR threshold voltage	V <sub>por</sub>		1.1	1.3	1.5	V
<b>Band-gap reference</b>						
Analog ground voltage	A <sub>gnd</sub>		2.3	2.5	2.7	V
Analog ground thermal coefficient	TC <sub>bg</sub>			15	50	$\mu\text{V}/^{\circ}$
Reference current mirror load drive voltage	V <sub>cref</sub>		1.8	2	2.2	V
<b>IR-chain amplifier and output driver</b>						
Common mode input range	CMIR		-0.1		V <sub>dd</sub> -3	V
Common mode rejection ratio	CMRR	$f \leq 100\text{kHz}$ R <sub>sens</sub> < 60k $\Omega$ *	75			dB
Power supply rejection ratio	PSSR	$f \leq 100\text{kHz}$	75			dB
Available gain settings	Air		55		5500	V/V
Gain tolerance	$\delta\text{Gir}$		-6.5		+6.5	%
Amplifier offset	V <sub>off</sub>				4	$\mu\text{V}$
Input referred white noise	V <sub>nir</sub>	rms-value			25	nV/ $\sqrt{\text{Hz}}$
Chopper frequency	f <sub>c</sub>			8		KHz
Output voltage range		I <sub>ROUT</sub>	0		V <sub>dd</sub> -0.2	V
Output source current	I <sub>od</sub>	I <sub>ROUT</sub>	1			mA
Output sink current	I <sub>os</sub>	I <sub>ROUT</sub>	20			$\mu\text{A}$
DC Output impedance, drive	r <sub>od</sub>	I <sub>ROUT</sub>			10	$\Omega$
DC Output impedance, sink	r <sub>os</sub>	I <sub>ROUT</sub>			100	$\Omega$
Capacitive load I <sub>ROUT</sub> pin	C <sub>max</sub>	I <sub>ROUT</sub>			50	pF
Amplifier bandwidth	BW			500		Hz
<b>Temp-chain amplifier and output driver</b>						
Common mode input range	CMIR		0.1		V <sub>dd</sub> -3V	V
Common mode rejection ratio	CMRR	$f \leq 100\text{kHz}$	75			dB
Power supply rejection ratio	PSSR	$f \leq 100\text{kHz}$	75			dB
TINP bias current	I <sub>tpb</sub>	bias current enabled	1/7		.1	i <sub>Cref</sub> *
Available gain settings	A <sub>temp</sub>		1		40	V/V

Parameter	Symbol	Test Conditions	Min	Typ	Max	Unit
Gain tolerance	$\delta G_{temp}$	bias current enabled	-6.5		+6.5	%
Amplifier offset	Voff				4	$\mu V$
Input referred white noise	Vtemp	rms-value			400	nV/ $\sqrt{Hz}$
Chopper frequency	fc			8		kHz
Output voltage range	ORtemp	TEMPOUT	0		Vdd-0.2	V
Output source current	Iod	TEMPOUT	1			mA
Output sink current	Ios	TEMPOUT	20			$\mu A$
DC Output impedance, drive	rod	TEMPOUT			10	$\Omega$
DC Output impedance, sink	ros	TEMPOUT			100	$\Omega$
Capacitive load TEMPOUT pin	Cmax	TEMPOUT			50	pF
Amplifier bandwidth	BW			500		Hz

#### Rel1 open drain relay driver

High voltage protection			32			V
output impedance	Ro			10		$\Omega$

#### Comp1 comparator

Potentiometer input range	IRirout	IROUT	0		100	% of Vrefp
---------------------------	---------	-------	---	--	-----	------------

#### ADC

Input stage gain			2.95	3	3.05	V/V
External Reference voltage	Vrefpex		1		3.3	V
Internal Reference voltage	Vrefp		2.4	2.5	2.6	V
Vrefp input leakage current	Ilvrefp	@150°C			5	$\mu A$
Resolution				12		bit
Monotonicity			guaranteed by design			
Differential non-linearity	DNL				0.4	LSB
Integral non-linearity	INL				½	LSB
Gain error		full scale			1	LSB
Total input-referred noise		Vref=3V			0.2	LSB

#### DAC

Resolution				8		bit
Monotonicity			guaranteed by design			
Differential non-linearity	DNL				½	LSB
Integral non-linearity	INL				½	LSB

\*Rsens is the impedance of the sensor connected between IRINP and IRINN for the IR-chain amplifier.

\*\*Icref is the current flowing out of pin CREF

### General Description

The MLX90313 is a versatile in-circuit programmable interface, which performs signal conditioning, linearisation and ambient temperature compensation, particularly for infrared sensors combined with a thermistor. Other types of sensors can also be used in various configurations. Sensors that can be used include pressure sensors, strain gauges, acceleration sensors etc.

The amplifier chains in MLX90313 are programmable in very broad ranges of gain, between 50 and 12000 for the IR-chain and between 1 and 120 for the Temp-chain. Both chains consist of high performance, chopper-stabilized amplifiers, providing excellent noise performance and low offset. The I/O configuration as well as analog settings are in-circuit programmable by means of the SPI-serial interface. This serial link can also be used to read out the output signals digitally. The circuit can either provide linear analog or PWM (Pulse Width Modulated) signal outputs, relative to an analog ground, or several combinations of analog and digital comparator driven outputs. Two comparators controlled by either one of the two linearised signals are available on chip with different possibilities for the threshold level, polarity and switching hysteresis. One of the comparators drives the open drain output. The user can provide the threshold for this comparator at the IROUT I/O pin with a simple potentiometer.

A bias current for the thermistor can be obtained at the TINP input by connecting an external resistor between the CREF pin and VSS. The standard package is SOIC-20.

### Unique Features

The MLX90313 integrates dual low noise programmable gain amplifier stages. Both thermistor and IR signal path can be configured to suit a large number of components and applications. The onboard analog to digital converter (ADC) combined with the digital linearisation unit results in linear output signals. These output signals are available as analog or digital output signal. Applications requiring digital temperature information can use single wire PWM output or SPI serial communication. The complete configuration and calibration is in-system programmable through the SPI interface. Combination of all these integrated features combined with a thermopile sensor make the MLX90313 a true high accuracy automotive grade single-chip infrared thermometer.

### Absolute Maximum Ratings

Supply Voltage, $V_{in1}$ (overvoltage)	80V
Supply Voltage, $V_{in}$ (overvoltage)	6V
Supply Voltage, $V_{in1}$ (operating)	16V
Supply Voltage, $V_{in}$ (operating)	5.5V
Reverse Voltage Protection	-5V
Supply Current, $I_{DD}$	5.6 mA
Output Current, $I_{OUT}$	3 mA
Operating Temperature Range, $T_A$	-40C to +125C
Operating Temperature Range, $T_S$	-55C to +150C
ESD Susceptibility	2 kV
Rel1 output impedance	10 ohms

### Pin-out

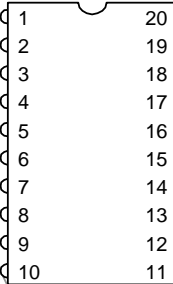

TINP	1	20	TEMPOUT
TINN	2	19	CSB
IRINP	3	18	SDOUT
IRINN	4	17	SCLK
VSS	5	16	TSTCLK
REL1	6	15	VDD
IROUT	7	14	VDD1
SDIN	8	13	AGND
TOUT1	9	12	VREFP
TOUT2	10	11	CREF

Pin	Symbol	Description
1	TINP	Temp-chain amplifier positive input
2	TINN	Temp-chain amplifier negative input
3	IRINP	IR-chain amplifier positive input
4	IRINN	IR-chain amplifier negative input
5	VSS	Supply pin
6	REL1	Open-drain relay driver output
7	IROUT	IR-chain amplifier output
8	SDIN	SPI data input
9	TOUT1	Test pin/ Oscillator output
10	TOUT2	Test pin, leave open
11	CREF	Bias current reference
12	VREFP	Reference voltage input/output
13	AGND	Analog ground, band-gap reference voltage
14	VDD1	Automotive Ignition supply pin
15	VDD	Regulated supply pin
16	TSTCLK	Clock for test mode; leave open
17	SCLK	SPI clock input
18	SDOUT	SPI data output
19	CSB	SPI chip select active low
20	TEMPOUT	Temp-chain amplifier output

## Pin Descriptions

### TINP

Temperature sensor positive input pin. The pin connects to the temp-chain amplifier and the on-chip biasing current source. The source is a mirrored version of the current running into CREF with programmable ratio. The current source can be switched off for use of external current biasing.

### TINN

Temperature sensor negative input.

### IRINP - IRINN

Thermopile sensor input pins.

VSS: Supply pin

### REL1

Open drain relay driver output. The typical on-resistance of this driver is  $<10\Omega$  with a supply voltage of  $VDD=5V$ . Different configurations are possible as shown below.

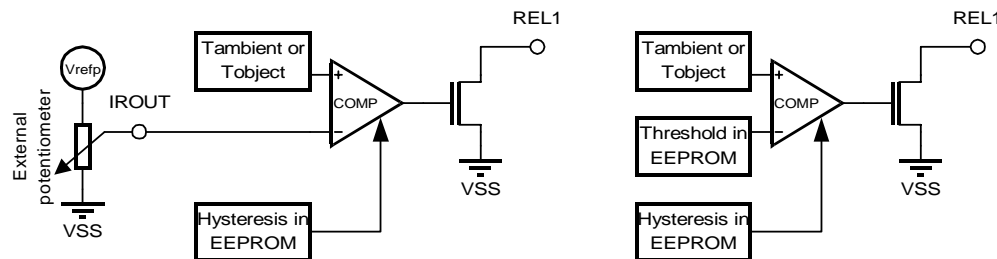

The comparator is a 12 bit digital comparator. The input polarity can be inverted or not. The threshold and hysteresis registers are 16 bit registers of which the 11 MSBs are used in the comparator circuitry. The voltage on the IROUT pin is sampled with 8 bit ADC referred between VREFP and VSS pins. Note. In case of potentiometer use the linearised analog output is not available. In this case the DAC is used as 8-Bit ADC for potentiometer (or other voltage source) monitoring.

### IROUT

IROUT/POTin analog/digital I/O pin. This pin can be configured as analog output of the IR sensor or as input for an external potentiometer. (see pin description of REL1). As analog output, this pin can either be connected to the analog amplified IR sensor signal or to the linearised object temperature by means of the DAC. The driver can source at least 1mA and sink at least 20 $\mu$ A to/from an external load. If the capacitive load on this pin exceeds 50pF, this load should be de-coupled by means of a series resistor. This pin can be configured also as digital output to transmit the IR temperature in PWM format. The pin is protected for over-voltage and can withstand 16V.

### SDIN

**Serial data input pin for the SPI. Data is accepted on the rising edge of the serial data clock (SCLK)**

### SDOUT

Serial data output pin for the SPI. Data is valid on the rising edge of the serial data clock (SCLK)

**SCLK**

Serial data clock from the external master to be supplied to this pin. Maximum frequency = 125kHz.

**CSB**

Active low, chip select pin for the SPI. Communication is started on the falling edge of CS and ended on the rising edge of CS.

**TOUT1 - TOUT2:**

Test pins. In normal mode, the internal clock signal of 1Mhz is present on TOUT1 and the clock of the chopper amplifier is present on TOUT2.

**CREF**

Current reference output. CREF is the reference voltage output for the temperature independent current source. The requirements for the resistor to be connected between CREF and VSS depend on the required accuracy and range of the ambient temperature measurement. The voltage level at CREF depends directly on the internal band-gap.

**VREFP**

Voltage reference I/O pin. This level is by default dependent on the on-chip band-gap reference source and can be programmed in range 2-4.5V from eeprom . This voltage is used as reference for the DAC, external applied potentiometer and 8-bit ADC. The chip can be configured to use an external reference voltage instead of the on-chip reference.

The pin is protected from over-voltage and can withstand 16V

**AGND**

Analog ground reference pin. This voltage is derived from the on-chip band-gap and has a typical level of 2.5V for maximum output range of the amplifiers. When IROUT and/or TEMPOUT are connected directly to the amplified analog signals, then these signals are referred to AGND. The regulator can be stopped from the eeprom configuration register. In this case the pin can be used for external reference for the 12-bit ADC.

The pin is protected from over voltage and can withstand 16V

**VDD1**

High voltage supply pin. This supply pin can be connected directly to an automotive ignition supply voltage. The internal regulator can operate with voltages between 7V and 80V.

**VDD**

5V regulated supply pin. The 5V regulated voltage from the on-chip regulator is available on this pin. The internal regulator can supply up to 20mA to external circuitry. VDD can also be used to supply the chip directly with an external 5V regulated supply.

**TEMPOUT**

TEMPOUT analog output/Comparator output pin. This pin can be configured as analog output of the

temperature sensor or as output of the internal comparator circuit. As analog output, this pin can either be connected to the analog amplified temperature sensor signal or to the linearised ambient temperature by means of the DAC.

When used as comparator output, different configurations are possible as shown below.

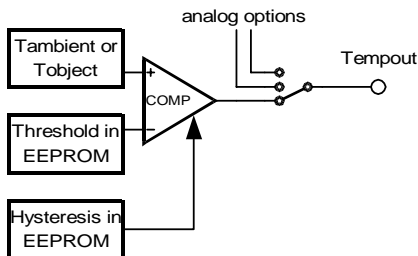

The driver can source at least 1mA and sink at least 20 $\mu$ A to an external load. If the capacitive load on this pin exceeds 50pF, the load should be de-coupled by means of a series resistor. The pin is also output for linearised Tambient in PWM mode. The pin is protected from over-voltage and can withstand 16V



### Analog Section

#### Supply regulator and Power-ON Reset

The on-chip supply regulator can be powered by an automotive ignition supply line (7V-80V). The chip can withstand SAE standard ignition transients. The resulting voltage of the regulator is available on VDD (5V±300mV). The VDD pin can source up to 20mA to external circuitry. The chip can also be supplied directly with a 5V regulated supply on pin VDD.

The power-on reset (POR) circuitry is completely internal. The chip is fully operational 16ms from the time the supply crosses 1.3V. The POR circuit will issue another POR if the supply voltage goes below 1.3V.

#### Band-gap, DAC and ADC references

The on-chip trimmable, curvature compensated band-gap circuitry provides a stable reference level (less than 10ppm per °C) for several derived reference potentials used for normal operation in MLX90313.

The analog ground at the AGND pin is directly derived from this band-gap voltage. The output voltages from both amplifier chains are relative to this potential. The AGND reference can be trimmed internally to (2.5V±20mV). The regulator at AGND pin can be switched off to minimize the current consumption. The pin can be also used as external input for the internal 12-bit ADC.

The reference voltages for ADC and DAC are also derived from the band-gap. The DAC reference is available at pin VREFP. The MLX90313 DAC reference voltage can be programmed on chip to one of the following values: 2, 2.5, 3, 3.5, 4 and 4.5 V. Depending on the customer application Melexis can program the linearised analog outputs for object and ambient temperatures providing absolute voltage/temperature dependence. The internal regulator for the DAC reference voltage can be switched off to minimize the consumption (if linearised analog output is not in use) or to use externally supplied reference for DAC reference in range 2 to 5V

The ADC reference is 2.5V typically. The chip can be also programmed to use external ADC reference connected to pin AGND. The current reference bias voltage (present at CREF pin) is also derived from the on-chip band-gap reference.

#### IR-amplifier chain

MLX90313 is available with gain settings for the IR-amplifier chain ranging from 55 to 5500. The gain can be selected by setting the appropriate bits of the 'Irgain1'-register (EEPROM address 00h) according to the table below. Any gain between the abovementioned limits can be obtained within an accuracy of ±6.5%. The amplifier input-referred white noise level is below 23nVrms/√Hz. In the application with IR-sensors, with output resistance of 50kΩ typical, the total system noise will however depend mainly on the noise of the sensor and will rise up to 45nVrms/√Hz. The offset for the chopper stabilized amplifier path can be largely calibrated out and amounts to maximum 4μV.

The common mode input range of the amplifier is -100mV to VDD - 3V. The output range of the amplifier is 0V to VDD-0.2V. The output of the amplifier is referred to the potential on AGND.

#### IR chain gain settings

$G_{IR} = G_{pr} \times G_b \times G_{pa} \times G_l$												
stage	$G_{pr}$		$G_b$				$G_{pa}$		$G_l$			
contr. bits	GCI0		GCI3	GCI2	GCI1		GCI4		GCI7	GCI6	GCI5	
setting	0	10	0	X	X	5	0	1	0	0	0	1.067
			1	0	0	10			0	0	1	1.143
			1	0	1	15			0	1	0	1.231
			1	1	0	20			0	1	1	1.333
	1	20*	1	1	1	25	1	5	1	0	0	1.455
			1	0	1	1.600						
			1	1	0	1.778						
			1	1	1	2.000						

\* This option is available only if ENLN=1

The pin ENLN controls both the noise level and distortion of the amplifier. If ENLN=1 the noise of the amplifier is 23nVrms/√Hz, the gain of 20 in first stage is available but the input signal must be less than 4 mV for less than 0.05% full scale distortion.

If ENLN is 0 then the span of the input signal can be ± 40mV with distortion less than 0.1% full scale. In this case the noise floor of the amplification chain increases 3 times.

### Temp-amplifier chain

MLX90313 is available with gain settings for the Temp-amplifier ranging from 5 to 50. The gain can be selected by setting the appropriate bits of the 'Temp gain and current control'-register (EEPROM address 02h) according to the table below. Any gain between the abovementioned limits can be obtained within an accuracy of ±6.5%. It is also possible to completely bypass the temperature amplifier and force the input signal directly to the ADC. The amplifier input-referred white noise level is below 400nVrms/√Hz.

The common mode input range of the amplifier is -100mV to VDD-3V. The output range of the amplifier is 0V to VDD-0.2V. The output of the amplifier is referred to the potential on AGND.

### Temp chain gain settings

$G_T = G_{pr} \times G_l \times M$												
stage	$G_{pr}$				$G_l$				$M$			
contr. bits	GCT2	GCT1	GCT0		GCT5	GCT4	GCT3		IRSEL2	IRSEL1	IRSEL0	
	0	0	0	1	X	X	X					
settin g	0	1	1	5	0	0	0	1.067	0	0	0	off
					0	0	1	1.143	0	0	1	1/7
	1	0	0	10	0	1	0	1.231	0	1	0	2/7
	1	0	1	15	0	1	1	1.333	0	1	1	3/7
	1	1	0	20	1	0	0	1.455	1	0	0	4/7
					1	0	1	1.600	1	0	1	5/7
	1	1	1	25	1	1	0	1.778	1	1	0	6/7
				1	1	1	1	2.000	1	1	1	1

Note: When the current mirror is on (all settings except IRSEL[2:0] = 000b) the gain is defined as follows:

$$G_T = \frac{V_{out}}{R_{sens} \cdot I_{cref}}$$

where Vout is the output of the analog amplifier chain, Rsens is the resistance of the sensor connected between TINP and TINN and Icref is the current out of CREF.

When the current mirror is off (IRSEL[2:0]=000b), M should be replaced by 1 and the gain is defined as follows:

$$G_T = \frac{V_{out}}{V_{in}}$$

where Vin is the voltage difference between TINP and TINN

If GCT[2:0]=0 then the temp chain will be completely off, the Timp pin will be connected directly to the ADC input, providing Gain=1

### Current Reference

The thermistor (or sensor) connected to TINP must be biased with a current source. This bias current is mirrored from the current through the external resistor between CREF and VSS. The voltage maintained at the CREF pin is derived from internal band-gap voltage, and thus constant. The typical value of the voltage at CREF pin is 2V.

The current mirror ratio can be set between 1/7 and 1 according to the table for the Temp-chain gain settings. The setting with IRSEL[2:0]=000b switches the current mirror off. In this case the thermistor must be biased by external circuitry.

### Analog-to-Digital Converter (ADC)

MLX90313 contains a 12-bit internal analog to digital converter. Real 12 bit conversion is achieved by a fully differential signal path of the converter. The input amplifier of the ADC has a fixed gain of 3. Automatic calibration is implemented in the background, which allows precise conversion in a very wide temperature range. The ADC sampling rate is 7k samples/second. The reference voltage for the ADC is normally a scaled version of the internal band-gap reference and is fixed to be 2.5V. Alternatively MLX90313 can be configured to work with an external reference potential applied to the AGND pin. In this case the appropriate bit in the configuration register (SELADREF bit in Confreg1) must be cleared. Internal ADC can work with references down to 1 V keeping the 12-bit resolution.

The ADC contains an interface circuit to scale and offset the analog signals in order to make the most efficient use of the available resolution. After amplification the IR and Temp sensor signals are referred to AGND voltage level (typical value 2.5V). The additional offset is scaled version of the AGND.

The ADC interface circuit is given below. The output of the Temp-chain is amplified relative to the voltage reference VrefT, which can be controlled with 2 bits (bit10 and bit9, EEPROM address 02h). The possible values for VrefT can be calculated according to the equation:

$$V_{refT} = \frac{V_{Agnd} \times 1.4 \times (63 + K)}{70}, \text{ where } K = 0 \text{ to } 3, \text{ corresponding to the value of the control bits.}$$

The typical values are 3.15, 3.20, 3.25 and 3.3V. If the temp path amplifier is bypassed then VrefT will be fixed to:  $Agnd \times 0.28 = 0.7V$  typical.

The output of the IR-chain is amplified relative to Refir and can be calculated according to the following equation:

$$V_{refir} = \frac{V_{Agnd} \times 1.4 \times (34 + K)}{70}, \text{ Where } K=0:31 \text{ depending on the selected value of Rsel}[4:0]$$

The typical values (for Agnd=2.5V) are listed in the table below:

ADC interface setting							
RSEL[4:0]	Refir [V]	RSEL[4:0]	Refir [V]	RSEL[4:0]	Refir [V]	RSEL[4:0]	Refir [V]
11111b	3.25	10111b	2.85	01111b	2.45	00111b	2.05
11110b	3.20	10110b	2.80	01110b	2.40	00110b	2.00
11101b	3.15	10101b	2.75	01101b	2.35	00101b	1.95
11100b	3.10	10100b	2.70	01100b	2.30	00100b	1.90
11011b	3.05	10011b	2.65	01011b	2.25	00011b	1.85
11010b	3.00	10010b	2.60	01010b	2.20	00010b	1.80
11001b	2.95	10001b	2.55	01001b	2.15	00001b	1.75
11000b	2.90	10000b	2.50	01000b	2.10	00000b	1.70

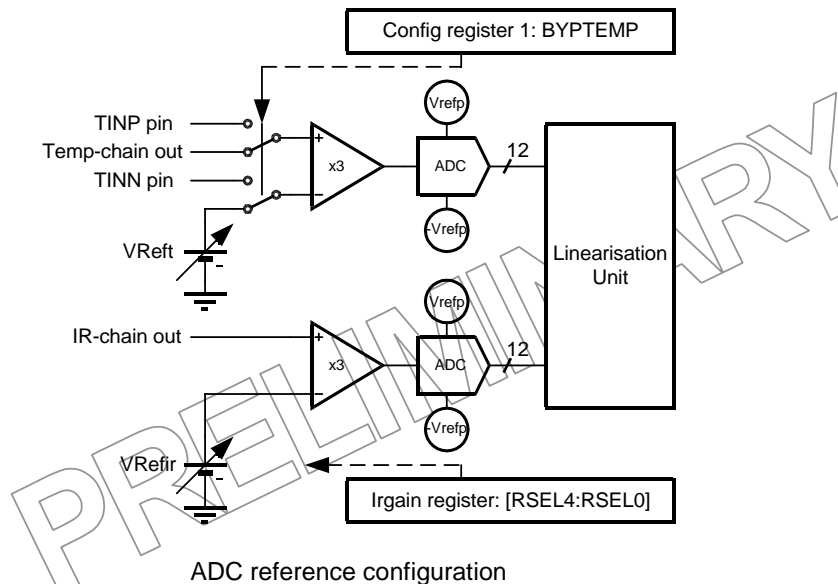

### Digital-to-Analog Converter (DAC)

A 8 bit digital to analog converter can be used to output the data for the linearised Tobject- and Tambient signals. The DAC can work with a internal programmable reference voltage, as well as with an external one. In case the internal reference voltage is used, this voltage can be monitored on the VREFP pin. If one wants to use his own reference voltage, this can be done by applying this voltage to the VREFP pin, and setting the appropriate configuration bit.

The result from D/A conversion is stored on hold capacitors and buffered. The signals are available at IROUT and TEMPOUT respectively, if the appropriate bits are set in the configuration register (EEPROM address 04h).

The reference value for the D/A can be programmed with 3 bits: SELDR[2:0] (register Irgain2) according to the table below:

SELDR2	SELDR1	SELDR0	ENDREFDIV	VREFP
0	0	0	0	2
0	0	1	0	2.5
0	1	0	0	3
0	1	1	1	3.5
1	0	0	1	4
1	0	1	1	4.5

For reference voltages higher than 3V the ENDREFDIV bit must be set. In this case the ASIC will divide internally the reference by 2 to provide proper input common mode for the output buffer amplifiers at pins IROUT and TEMPOUT. In this case the result of the D/A conversion result will be amplified times 2 by the output amplifiers, which will ensure the requested signal swing.

Melexis can rescale the DAC reference and eeprom table for the linearisation unit to provide absolute analog output. This way, at maximum calibrated temperature, the voltage of IROUT or TEMPOUT pin will always correspond to the requested D/A reference voltage.

The regulator for the VREFP voltage can be stopped and an external reference voltage can be forced and used from the D/A. The regulator for DAC reference voltage can also be stopped (bit ENDACREF=0) when DAC is not in use. This will save some supply current.

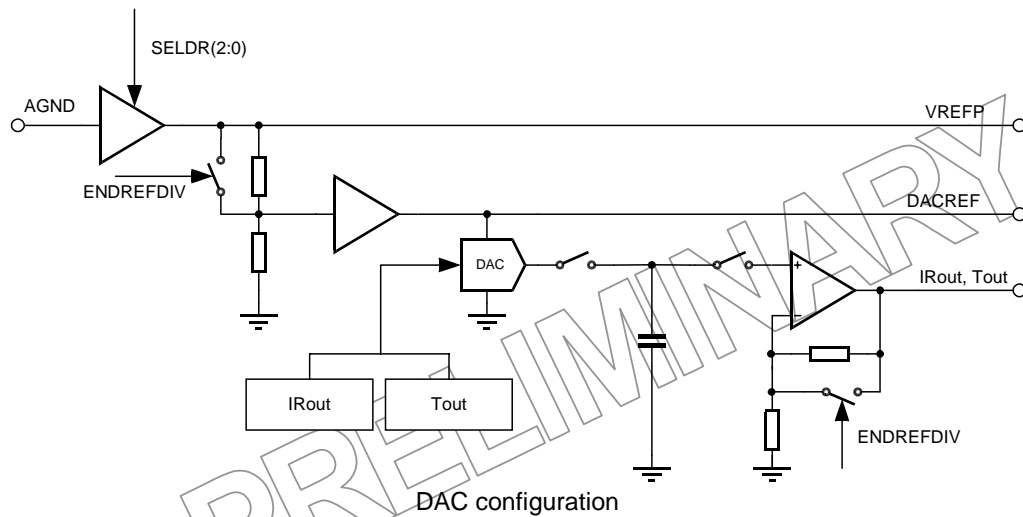

### Output drivers

The IROUT and TEMPOUT outputs can be connected to various signals available: The amplified analog signals (IRINP-IRINN and TINP-TINN), the linearised object respectively ambient temperature signals, or to the comparator circuitry. The IROUT and TEMPOUT pin drivers can source 1mA and sink 20µA and are reverse voltage protected down to -5V relative to VSS. The available configurations are described in table below.

Input/Output Setting				
I/O pin	IROUT		TEMPOUT	
Control Bits	IROUTC[1:0]	Configuration	TOUTC[1:0]	Configuration
Setting	00b	IR-chain out	00b	Temp-chain out
	01b	Linear Tobject	01b	Linear Tambient
	10b	Threshold Rel1 input	10b	Comp1 out
	11b	PWM out	11b	PWM out

REL1 is an open drain relay driver output controlled by the on-chip comparator circuitry. The available configurations are described in the section on the comparator circuitry.

### Digital Section

The digital unit on board of MLX90313 realizes all functions for control, configuration, measurements and linearisation. It contains several registers, ALU and control logic. All functions of the ASIC are hardware fixed and controlled by different state machines, which execute in sequence all procedures necessary for normal chip operation.

#### Internal registers overview

The table below contains all internal registers, their addresses for access via SPI serial interface and short functional description. Depending on their function they can be divided in 3 groups:

- Control registers: they keep the configuration of the chip including all gain settings of the amplifiers, analog ground level, band-gap and oscillator trimming data, etc. All this data is stored in eeprom and after POR the system loads it in the corresponding peripheral registers.
- Data registers: they keep all data for offsets, results from measurements and linearisation of both chains. This registers can be read via spi in normal mode and are write accessible during test mode.
- Computation registers. These registers support the computation unit and keep all temporary data necessary for digital low pass filtering, linearisation and comparator functions. They are not accessible via SPI in normal mode.

Internal Register Table.					
Register	Function	Address		Access via spi	
		Dec	Hex	Write	Read
IRGAIN1	IR-chain settings	0	00h	Test mode	No
IRGAIN2	IR-chain settings	1	01h	Test mode	No
TEMPGAIN	Temp-chain settings	2	02h	Test mode	No
CONFREG1	Configuration	3	03h	Test mode	Always
CONFREG2	Configuration	4	04h	Test mode	Always
OSCILLATOR	Oscillator	5	05h	Test mode	No
BGCONTROL	Bandgap control	6	06h	Test mode	No
LPF	Low Pass Filter	7	07h	Test mode	No
ADCREG	ADC output data	8	08h	Test mode	Always
IROUT	Tobject (lin)	9	09h	Test mode	Always
TOUT	Tambient (lin)	10	0Ah	Test mode	Always
IRDATA	IR-chain output	11	0Bh	Test mode	Always
TDATA	Temp-chain output	12	0Ch	Test mode	Always
IROS	IR-chain offset	13	0Dh	Test mode	Always
TOS	Temp-chain offset	14	0Eh	Test mode	Always
MAINSTM	Main state machine	15	0Fh	Test mode	No
TEST	Test mode control	16	10h	Always	No
REG TEMP	Temporary register for test			Test mode	No
REG A	Accumulator A			Test mode	No
REG B	Accumulator B			Test mode	No
TESTCTRL 1	Test control	20	14h	Test mode	No
REG C	Accumulator C			Test mode	No
REG E	Accumulator E			Testmode	No
TESTCTRL 2	ADC test control	23	17h	Test mode	No
WP	Eeprom write protect	24-31	18h-1Fh	Always	No

Configuration and control registers overview and bit functions as they are read from the module

Bit functions								
REGISTERH	B15	B14	B13	B12	B11	B10	B9	B8
REGISTERL	B7	B6	B5	B4	B3	B2	B1	B0
IRGAIN1H	ENDREFDIV	ENDAC	ENLN	GCI7	GCI6	GCI5	GCI4	GCI3
IRGAIN1L	GCI2	GCI1	GCI0					
IRGAIN2H	AGNDC3	AGNDC2	AGNDC1	AGNDC0	SELDR2	SELDR1	SELDR0	RSEL3
IRGAIN2L	RSEL2	RSEL1	RSEL0					
TEMPGAINH	TRSEL1	TRSEL0	IRSEL2	IRSEL1	IRSEL0	GCT5	GCT4	GCT3
TEMPGAINL	GCT2	GCT1	GCT0					
CONFREG1H	ERROR	ENVR	HVSUP	SELADREF	POTMET	COMP1V	COMP1P	BYPTEMP
CONFREG1L	REL1V	REL1P	EEWREN	TESTMODE				
CONFREG0H	IROUTC1	IROUTC0	TOUTC1	TOUTC0	SUBINC	SUBDEC	NTC	TIMEOS3
CONFREG0L	TIMEOS2	TIMEOS1	TIMEOS0					
OSCH								ENAGNDB
OSCL								
BGH								
BGL								
LPFH	RSEL4	ENOSM	ENTAV	IROS	TOS	LPFIR2	LPFIR1	LPFIR0
LPFL	LPFT2	LPFT1	LPFT0					
TESTH	1	0	1	0	0	1		
TESTL								
TESTCTRL1H								
TESTCTRL1L								
TESTCTRL2H								
TESTCTRL2L								
WPH								
WPL		1	1	0	0	1	0	1

### Register Descriptions

#### IRGAIN1

Read access: No. The data is accessible for read via SPI only from eeprom address 00h.  
Write access: Directly to the register in test mode. To eeprom if WP-register is correctly set.

IRGAIN1 bit functions			
Name	POR	val	Function
ENDREFDIV	X	1	Divide the reference for the DAC and enable output amplification by 2 of the To and Ta outputs. Must be set for Vref=3.5V,4V,4.5V.
ENDAC	X	1	Enable the DAC regulator
ENLIN	X	1	Enable low noise.
GCI[7:0]	X	00000000-11111111	Control the gain of the IR amplifier chain (see 'IR amplifier chain')

#### IRGAIN2

Read access: No. The data is accessible for read via SPI only from eeprom address 01h.  
Write access: Directly to internal register in test mode. To EEprom if WP-register is correctly set.

IRGAIN2 bit functions			
Bit	POR	val	Function
AGNDC [3:0]	X	0000-1111	Reserved
SELDR [2:0]	X		Adjustment of the DAC reference.
	X	000	Vref = 2V
	X	001	Vref = 2.5V
	X	010	Vref = 3V
	X	011	Vref = 3.5V

IRGAIN2 bit functions			
Bit	POR	val	Function
	X	100	Vref = 4V
	X	101	Vref = 4.5V
RSEL[3:0]	X	0000-1111	Select the value of the analog ground for IR signal path. The bits are 5, RSEL4 is in LPF register (see 'ADC' part)

### TEMPGAIN

Read access: No. The data is accessible for read via SPI only from eeprom address 02h.

Write access: Directly to internal register in test mode. To EEprom if WP-register is correctly set.

TEMPGAIN bit functions			
Bit	POR	val	Function
TRSEL[1:0]	X	00-11	Reference voltage for Tambient measurement at ADC interface input.
IRSEL[2:0]	X	000-111	Current mirror ratio: See under M in table 'Temp chain gain settings' in the section on the Temp-amplifier chain (analog features)
GCT[5:0]	X	000000-111111	Temp-gain: See table 'Temp-chain gain settings' in the section on the temp-amplifier chain (analog features)

### CONFREG1

Read access: Directly from internal registers or EEprom.

Write access: Directly to internal register in test mode. To EEprom if WP-register is correctly set.

CONFREG1 bit functions			
Bit	POR	val	Function
Fatal Error	X	1	Flags Multiple eeprom failure. Hamming coding can detect and correct only one bit per address. Bit will be cleared when going in test mode, disabling EEPROM protection and returning in normal mode. (for diagnostics only)
ENVR	X	1	Stops the internal reference for DAC (Pin VREF). The reference voltage can be supplied externally. If ENDAC=0 then VREF is input.
HVSUP	1	1	Enable the regulator for battery supply. NOTE!!! After POR this regulator will be always on. It can be stopped from EEPROM data.
SELADREF	X	0	External supply of ADC reference to AGND pin.
		1	Enable the internal ADC reference (connected to AGND pin).
POTMET	X	0	Sets threshold level for Rel1 to THRel1 in EEprom (address 75h)
		1	Sets potentiometer input (pin IROUT) as threshold level
COMP1V	X	0	Sets Tobject as target voltage for comparator Comp1
		1	Sets Tambient as target voltage for comparator Comp1
COMP1P	X	0	Sets polarity of Comp1: Inverting
		1	Sets polarity of Comp1: Non-inverting
BYPTEMP	X	0	Output of Temp amplifier path is connected to ADC
		1	Connects TINP-TINN directly to the ADC, bypassing the Temp-chain
REL1V	X	0	Sets Tobject as target voltage for Rel1
		1	Sets Tambient as target voltage for Rel1
REL1P	X	0	Sets polarity of Rel1: Inverting
		1	Sets polarity of Rel1: Non-inverting
EEWREN	0	1	Enables write access in EEPROM *write protect
TESTMODE	0	1	Indicates chip is in test mode *write protect

\*control bits EEWREN and TESTMODE are write protected. Their values can be set only with writing the appropriate data in 'Test' and 'WP' registers. These bits are flags which indicate the system operation



mode.

*CONFREG0*

CONFREG0 bit functions			
Bit	POR	val	Function
IROUTC[1:0]		00b	IROUT pin function: IR-chain out
		01b	IROUT pin function: Linear Tobject
		10b	IROUT pin function: Threshold Rel1 input
		11b	IROUT pin function: PWM out
TOUTC[1:0]		00b	TEMPOUT pin function: Temp-chain out
		01b	TEMPOUT pin function: Linear Tambient
		10b	TEMPOUT pin function: Comp1 out
		11b	TEMPOUT pin function: PWM out
SUBINC		0	2nd order derivative of thermistor function is positive (used if NTC=0)
		1	2nd order derivative of thermistor function is negative (used if NTC=0)
SUBDEC		0	2nd order derivative of thermistor function is positive (used if NTC=1)
		1	2nd order derivative of thermistor function is negative (used if NTC=1)
NTC		0	Used thermistor is PTC
		1	Used thermistor is NTC
TIMEOS[3:0]		0000	Offset calibration interval: 0'00"
		0001	Offset calibration interval: 0'02"
		0010	Offset calibration interval: 0'17"
		0011	Offset calibration interval: 0'19"
		0100	Offset calibration interval: 1'07"
		0101	Offset calibration interval: 1'09"
		0110	Offset calibration interval: 1'24"
		0111	Offset calibration interval: 1'26"
		1000	Offset calibration interval: 2'14"
		1001	Offset calibration interval: 2'16"
		1010	Offset calibration interval: 2'31"
		1011	Offset calibration interval: 2'33"
		1100	Offset calibration interval: 3'21"
		1101	Offset calibration interval: 3'23"
		1110	Offset calibration interval: 3'38"
		1111	Offset calibration interval: 3'40"

*OSCCTRL*

Read access: No. The data is accessible for read via SPI only from eeprom address 05h.

Write access: Only in test mode for both writing directly to internal registers and writing to Eeprom if WP register is correctly set.

*BGO: Reserved*

Read access: No. The data is accessible for read via SPI only from eeprom address 06h.

Write access: Only in test mode for both writing directly to internal registers and writing to Eeprom if the WP register is correctly set.

*LPF*

Read access: No. The data is accessible for read via SPI only from eeprom address 07h.

Write access: Only in test mode for both writing directly to internal registers and writing to Eeprom if the WP register is correctly set.

This register keeps the calibration data for the time constants of digital low pass filters of both channels (see section Linearisation Unit).

LPF bit functions			
Bit	POR	Val	Function
RSEL4		0	Refer to ADC interface setting
ENOSMB		0	Enable offset measurement of both IR & Temp channels.
		1	Disable offset measurement of both IR & Temp channels.
ENTAV		0	Reserved for future development. Reset it for all applications.
		1	Reserved for future development. Reset it for all applications.
IROS*		0	Number of averaged offset measurements for IR chain: 512
		1	Number of averaged offset measurements for IR chain: 1024
TOS*		0	Number of averaged offset measurements for Temp chain: 512
		1	Number of averaged offset measurements for Temp chain: 1024
LPFIR[2:0]		Number of averaged points for IR measurement	
		00b	64
		01b	128
		10b	256
		11b	512
		100b	1024
LPFT[2:0]		Number of averaged points for Temp measurement	
		00b	64
		01b	128
		10b	256
		11b	512
		100b	1024

### ADCREG

Read access: Directly via SPI in all modes.  
Write access: Directly to internal register in test mode.

This register keeps the result from last analog to digital conversion..

### IROUT

Read access: Directly from internal register.  
Write access: Directly to internal register in test mode.

This register keeps the linearised object temperature. (Tobject)

Register format:

Bit	15	14	13	12	11	10	9	8	7	6	5	4	3	2	1	0
Name	D11	D10	D9	D8	D7	D6	D5	D4	D3	D2	D1	D0	OVH	OVL	FE	Res

D11..D0 : 12 bit temperature data  
OVH: Overflow flag for Tambient measurement, Ta>Tamax, D[11:0] set to FFFh  
OVL: Underflow flag for Tambient measurement, Ta<Tamin, D[11:0] set to 000h  
FE: Fatal Error in eeprom.  
Res: Not used, always zero.

Note that the last 4 bits are the status register.

### TOUT

Read access: Directly from internal register.

Write access: Directly to internal register in test mode.

This register keeps the linearised ambient temperature. ( $T_{ambient}$ )

Register format:

Bit	15	14	13	12	11	10	9	8	7	6	5	4	3	2	1	0
Name	D11	D10	D9	D8	D7	D6	D5	D4	D3	D2	D1	D0	OVH	OVL	FE	Res

D11..D0 : 12 bit temperature data

OVH: Overflow flag for  $T_{ambient}$  measurement,  $T_a > T_{amax}$ , D[11:0] set to FFFh

OVL: Underflow flag for  $T_{ambient}$  measurement,  $T_a < T_{amin}$ , D[11:0] set to 000h

FE: Fatal Error in eeprom.

Res: Not used, always zero.

Note that the last 4 bits are the status register. These bits are identical to the last 4 bits of the IROUT register.

### IRDATA

Read access: Directly from internal register.

Write access: Directly to internal register in test mode.

This register keeps the measured IR data, compensated with the current offset of the amplifier (stored in Iros register).

### TDATA

Read access: Directly from internal register.

Write access: Directly to internal register in test mode.

This register keeps the measured Temp data, compensated with the current offset of the Temp amplifier (stored in Tos register).

### IROS

Read access: Directly from internal register.

Write access: Directly to internal register in test mode.

This register keeps the offset of the IR amplifier. Each measurement from IR amplifier will be compensated with this offset.

### TOS

Read access: Directly from internal register.

Write access: Directly to internal register in test mode.

This register keeps the offset of the Temp amplifier. Each measurement from Temp amplifier will be compensated with this offset.

*MAINSTM: Reserved*

Read access: No  
Write access: Directly to internal register in test mode

*TEST*

Read access: No.  
Write access: Directly to internal register.

This register determines the chip mode. It is cleared after POR which corresponds to normal mode. Writing the proper data in this register will put the chip in test mode which will be indicated with bit 'Test' from confreg0.

Test register			
Bit	POR	val	Function
B[15:9]	0000000b	1011001b	Forces chip in test mode
		any other	Normal mode (default)
B[8:0]	00000000b	X	

*WP*

Read access: No.  
Write access: Directly to internal register via SPI.

The register controls the write access to the eeprom. After POR this register is cleared and the eeprom is protected, no write access available. Writing the proper data in this register will remove the write protection of the eeprom and bit EEWREN (bit 1 in Confreg1) will be set.

Eeprom write protect register			
Bit	POR	val	Function
B[15:9]	00000000b	X	
B[6:0]	0000000b	1100101b	Enables write access to Eeprom*
		any other	Sets Eeprom write protect

\* The addresses 00-07h and 79-7Fh will be still protected. Write access here requires also 'Test mode'.

### Eeprom Description

MLX90313 contains 128 x 16 EEPROM memory. The memory can be accessed through the serial interface. The 11 most significant bits are data bits and the 5 less significant bits are control bits used for the Error Check and Correction system (ECC). After POR the ASIC reads the full eeprom contents, checks it and corrects the single errors (1 wrong bit per address). If higher order error is discovered then the bit 'fatal error' will be set (see Confreg1 description in previous section).

The memory has two levels of protection. After POR the write access to the eeprom will be disabled. The external unit can remove this level of protection writing proper data in WP register. In this case all addresses in range 08-77h will be available for write access. The first and last 8 addresses will still be disabled. The write access to these cells is available only if the write protection is removed and the chip is in test mode.

### Eeprom map overview

Address list eeprom				
Register name	Function	Address		Write access
		Dec	Hex	
IRGAIN1	IR-chain settings	0	00h	test mode**
IRGAIN2	IR-chain settings	1	01h	test mode
TEMPGAIN	Temp-chain settings	2	02h	test mode
CONFREG1	Configuration	3	03h	test mode
CONFREG2	Configuration	4	04h	test mode
OSCCTRL	Oscillator control	5	05h	test mode
BGCTRL	Bandgap control	6	06h	test mode
LPF	Low Pass Filter	7	07h	test mode
CALIBRATION	Look up table linearisation.	8-111	08h-6Fh	WP*
IOS-TEMP	Initial offset Temp-chain	112	70h	WP
IOS-IR	Initial offset IR-chain	113	71h	WP
RESERVED		114	72h	WP
THCOMP1	Threshold for comparator Comp1	115	73h	WP
HSCOMP1	Hysteresis for comparator Comp1	116	74h	WP
THREL1	Threshold for comparator of Rel1	117	75h	WP
HSREL1	Hysteresis for comparator of Rel1	118	76h	WP
RESERVED		119	77h	
CHIP-ID	Data	120-127	78h-7Fh	test mode

\*WP: Write access to EEprom is controlled by the content of the internal register WP

\*\*Test mode: Write access controlled by the internal register WP and only available in test mode

The last 8 addresses 0x78 to 0x7F are free to use for the user. They can hold some calibration data or identification number. All data programmed into the eeprom must pass the error checking. Therefore, one must add 5 hamming bits to the eeprom data, in the 5 least significant bits.

### Eeprom bit definitions

Following table gives the bit definitions for all addresses that can be modified by the user. All other addresses contain specific calibration data and should be left unchanged.

Note that some bits marked "RES" are reserved and should never not be changed by the user. If other bits in such an address must be changed, read original contents first to get the status of the reserved bits.

EEPROM BIT DEFINITIONS									
ADDRESS (HEX)	REGISTERH REGISTERL	B15 B7	B14 B6	B13 B5	B12 B4	B11 B3	B10 B2	B9 B1	B8 B0
0x00	IRGAIN1H IRGAIN1L	ENDREFDIV GCI2	ENDAC GCI1	ENLN GCI0	GCI7 K	GCI6 H4	GCI5 H3	GCI4 H2	GCI3 H1
0x01	IRGAIN2H IRGAIN2L	AGNDC3 RSEL2	AGNDC2 RSEL1	AGNDC1 RSEL0	AGNDC0 K	SELDR2 H4	SELDR1 H3	SELDR0 H2	RSEL3 H1
0x02	TEMPGAINH TEMPGAINL	TRSEL1 GCT2	TRSEL0 GCT1	IRSEL2 GCT0	IRSEL1 K	IRSEL0 H4	GCT5 H3	GCT4 H2	GCT3 H1
0x03	CONFREG1H CONFREG1L	ENVR REL1P	HVSUP RES	SELADREF RES	POTMET K	COMP1V H4	COMP1P H3	BYPTEMP H2	REL1V H1
0x04	CONFREG0H CONFREG0L	IROUTC1 TIMEOS2	IROUTC0 TIMEOS1	TOUTC1 TIMEOS0	TOUTC0 K	SUBINC H4	SUBDEC H3	NTC H2	TIMEOS3 H1
0x05	OSCH OSCL	RES RES	RES RES	ENAGNDB RES	RES K	RES H4	RES H3	RES H2	RES H1
0x06	BGH BGL	RES RES	RES RES	RES RES	RES K	RES H4	RES H3	RES H2	RES H1
0x07	LPFH LPFL	RSEL4 LPFT2	ENOSM LPFT1	ENTAV LPFT0	IROS K	TOS H4	LPFIR2 H3	LPFIR1 H2	LPFIR0 H1
0x73	THComp1	THR10 THR2	THR9 THR1	THR8 THR0	THR7 K	THR6 H4	THR5 H3	THR4 H2	THR3 H1
0x74	HSComp1	HST10 HST2	HST9 HST1	HST8 HST0	HST7 K	HST6 H4	HST5 H3	HST4 H2	HST3 H1
0x75	THRel1	THR10 THR2	THR9 THR1	THR8 THR0	THR7 K	THR6 H4	THR5 H3	THR4 H2	THR3 H1
0x76	HSRel1	HST10 HST2	HST9 HST1	HST8 HST0	HST7 K	HST6 H4	HST5 H3	HST4 H2	HST3 H1
0x78 - 0x7F	USER1..7	UDATA10 UDATA2	UDATA9 UDATA1	UDATA8 UDATA0	UDATA7 K	UDATA6 H4	UDATA5 H3	UDATA4 H2	UDATA3 H1

### Eeprom Hamming coding

All addresses in the eeprom are coded using hamming code. Therefore, if one wants to program data into any eeprom address, the hamming bits must be calculated first. This is not done by the

There are 11 bits + 4 hamming bits + 1 extra redundant bit in the eeprom. Data bits are numbered D10..D0, Hamming H4..H1, the extra bit is called K.

The bit definitions in the eeprom words are:

Pos	15	14	13	12	11	10	9	8	7	6	5	4	3	2	1	0
name	D10	D9	D8	D7	D6	D5	D4	D3	D2	D1	D0	K	H4	H3	H2	H1

The hamming bits are calculated as follows:

$$H1 = P(D0, D1, D3, D4, D6, D8, D10)$$

H2 = P(D0,D2,D3,D5,D6,D9,D10)

H3 = P(D1,D2,D3,D7,D8,D9,D10)

H4 = P(D4,D5,D6,D7,D8,D9,D10)

The extra K bit is calculated as:

K = P(D10,D9,D8,D7,D6,D5,D4,D3,D2,D1,D0,H4,H3,H2,H1)

Note :P is parity over the noted data bits. Parity is 1 if the number of ones is odd.  
When reading eeprom addresses, the numerical value can be found by simply dividing the returned data by 32.

PRELIMINARY

**90313 Algorithm**

The algorithm of the ASIC is divided in several operations: ECC, initialization, offset measurement, object and ambient measurement and offset cancellation, linearisation, comparator functions. Each of this operation is controlled from the main state machine. The sequence and control of all these state machines is controlled from main state machine. The normal flow of the procedure is show on the diagram below.

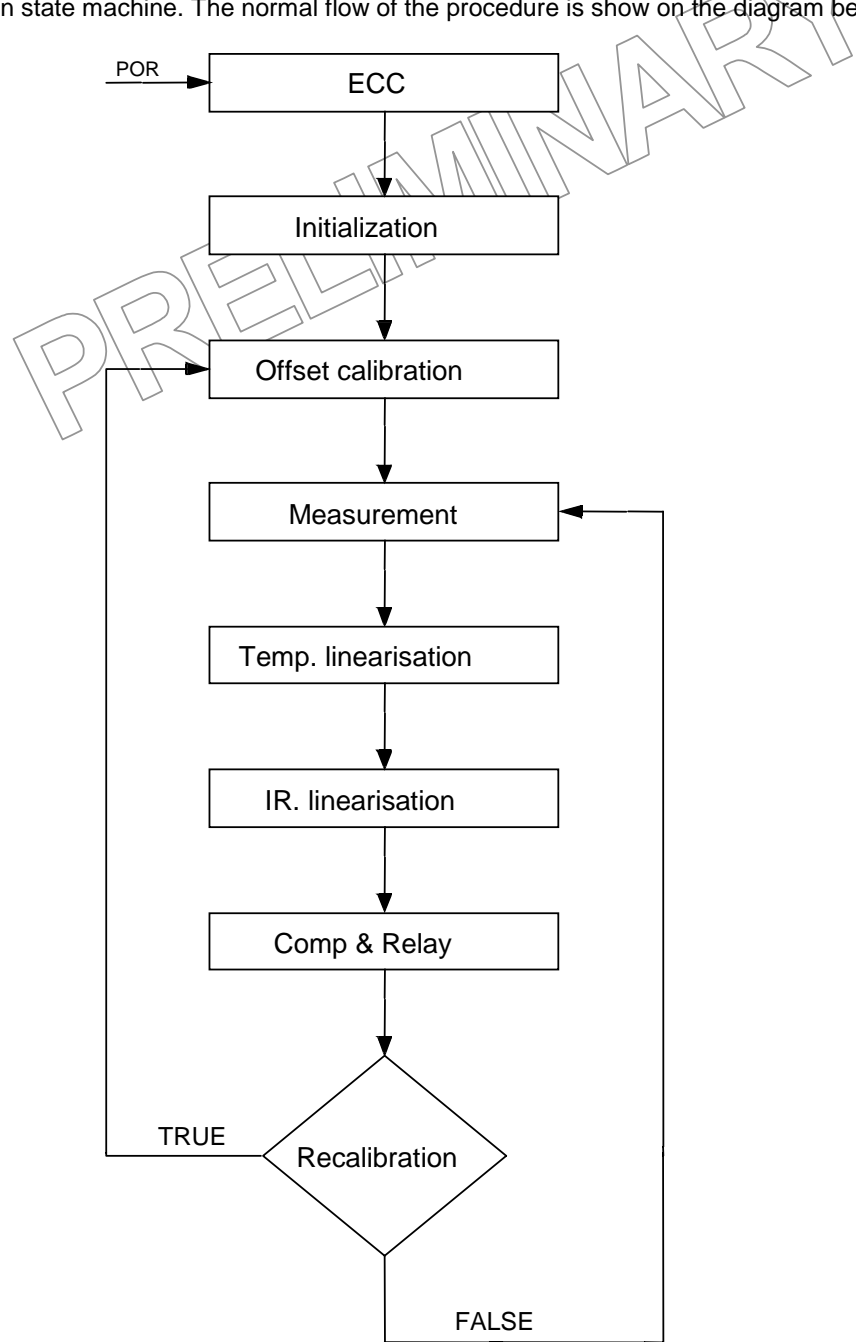

Main state machine control flow



### *Error Check and Correction (ECC)*

The ASIC starts this procedure only after Power On Reset. The state machine reads all data in the eeprom and corrects all single errors (1 wrong bit per address) if necessary. The wrong information from the eeprom will be refreshed with correct one. In case of double error (2 wrong bits per address) which can only be detected, not corrected, the system will leave the data in the address and will set the flag 'Fatal error' (bit 1 in status register). This data is available through SPI or PWM.

### *Initialization*

At this step the system reads its configuration from the eeprom. All data from eeprom addresses 00-07h will be filled in the corresponding peripheral registers. After this step the ASIC is ready for normal operation.

### *Offset measurement (offset drift compensation)*

The offset measurement is run periodically from the main state machine. The customer can select one of 16 possible interval times for offset measurement (see 'CONFREG0 bit functions'). Depending on the selected values for bits IROS and TOS in LPF register (address 07h in EEPROM) the average of 512 or 1024 measurements is stored. The time this measurement takes is about 75ms or 150ms, depending on the number of measurements taken. Note that during this time the outputs are kept on their last value before calibration started, so the current temperature is not available during offset calibration. The measured offset results will be stored in IROS (for IR amplifier chain) and TOS (for Temp amplifier chain) registers.

### *Measurement and offset cancellation*

The results from analog to digital conversion for both channels will be the mean of custom defined number of measurements, controlled from the LPF register (address 07 in eeprom). This data will be compensated with corresponding offsets, stored in IROS and TOS registers and final offset free data will be stored in IRDATA (for IR amplifier chain) and TDATA (for Temp amplifier chain) registers. The number of measurements of which the averaging is taken can vary between 64 and 1024 (see 'LPF register bit functions') and can be selected independently for both channels.

### *Linearisation*

Linearisation proceeds in two steps and can be described by the picture below. In the first step the ambient temperature is calculated from the measured signal at TINP-TINN. The system outputs a digital value for the ambient temperature based on the calibration data. The value is stored in a dedicated register and from there available for the DAC and PWM (Tambient-register, address 0Ah). The register can also be read digitally by means of the SPI.

The system is developed to support different temperature sensors. 3 bits in the configuration register (EEPROM address 03h), determine the type of characteristic. NTC defines the first derivative of the temperature sensor (NTC-type is logical 1, PTC-type is logical 0). SUBDEC and INCDEC define the

second derivative of the temperature sensor  $\left(\frac{d^2VRth}{dT^2}\right)$ .

The result of the linearisation is stored as the 12 MSB's of the Tambient-register (or TOUT-register). The code 000h will correspond to Tamin, FFFh will correspond to Tamax. These two limits are determined by

calibration. Accordingly the output resolution will be  $\frac{T_{a\max} - T_{a\min}}{4096}$  in K per LSB

In the second step the value of the ambient temperature is combined with the measured signal at IRINP-IRINN to obtain a calculated value for the so-called object temperature, based on the calibration data. The value is stored in a dedicated register and from there available for the DAC and PWM (Tobject-register, address 09h). The register can also be read digitally by means of the SPI.

The result of the linearisation is stored as the 12 MSB's of the Tobject-register (or IROUT-register). The

code 000h will correspond to  $T_{min}$ , FFFh will correspond to  $T_{max}$ . These two limits are determined by calibration. Accordingly the output resolution will be  $\frac{T_{o\ max} - T_{o\ min}}{4096}$  in K per LSB.

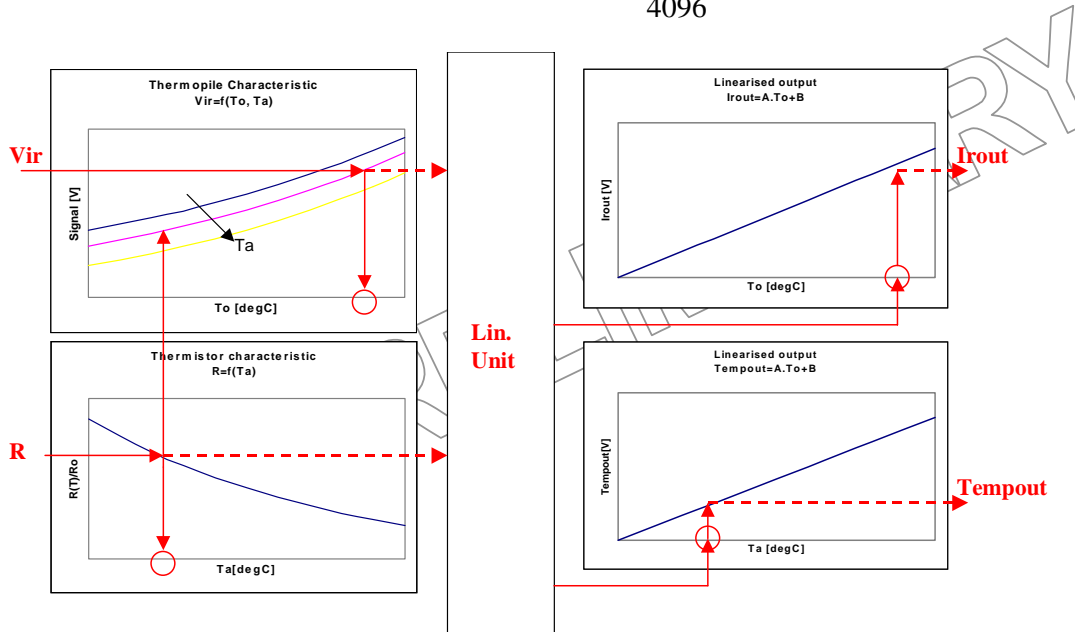

When reading the linearised data digitally by means of the SPI, a 16-bit word is returned. The 12 MSB's contain the temperature value as described above, the 4 LSB's form a status register, which is the same for both the IROUT address and the TOUT. The meaning of the individual bits is explained in the table below.

Linearisation Status Register			
S[3:0]	Meaning		
1 X X X	Overflow flag for Tambient measurement, $T_a > T_{amax}$ , TOUT[15:4] set to FFFh		
X 1 X X	Underflow flag for Tambient measurement, $T_a < T_{amin}$ , TOUT[15:4] set to 000h		
X X 1 X	Flag for Fatal Error in eeprom *		
X X X 0	Not used, always zero		

\*Fatal Error is the uncorrectable error in EEPROM (more than 2 wrong bits per address). When this error occurs, the normal process flow does not change, but the results may go wrong.

The status register is particularly important when an overflow (or underflow) condition occurs for the  $T_a$ -measurement. If the overflow condition occurs IROUT register will be set to FFFh, if underflow - IROUT will be 000h. If the user selects to monitor the analogue output through the DAC, then care must be taken to ensure that  $T_{ambient}$  will never exceed the selected range, as the over- or underflow condition is not flagged.

### Comparators and relay output

MLX90313 contains two programmable 12 bit digital comparators. For each circuit the target signal, the threshold and hysteresis can be programmed in different configurations, according to the table below. The principle of operation is shown in the following schematics. The threshold and hysteresis values are stored in eeprom, the control bits are part of the configuration register. The REL1 comparator threshold can be either read from EEPROM (address 75h) or controlled by an external potentiometer connected to IROUT. Note that the threshold and hysteresis registers in eeprom are only 11 bits wide. Therefore a zero is added in the LSB position to the threshold and hysteresis registers, making this register also 12 bits.

Comp1 circuitry setting				
	Comp1 source signal		Comp1 Polarity	
Control Bit	COMP1V		COMP1P	
Setting	0	Tobject	0	Inverting
	1	Tambient	1	Non-inverting

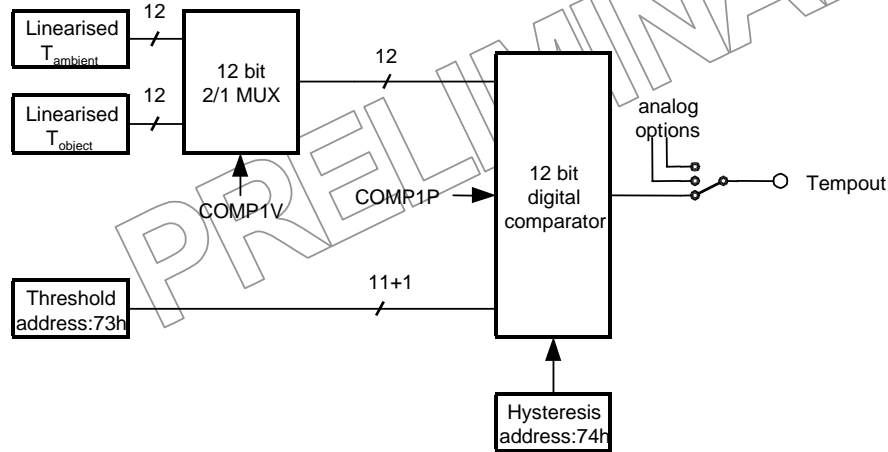

Comparator1 (COMP1) Configuration diagram

Note that the threshold for COMP1, is always in eeprom address 0x73.

Rel1 circuitry setting						
	Rel1 source signal		Rel1 Threshold source		Rel1 Polarity	
Control Bit	REL1V		POTMET		REL1P	
Setting	0	Tobject	0	[75h]	0	Inverting
	1	Tambient	1	IRDATA [03h]	1	Non-inverting

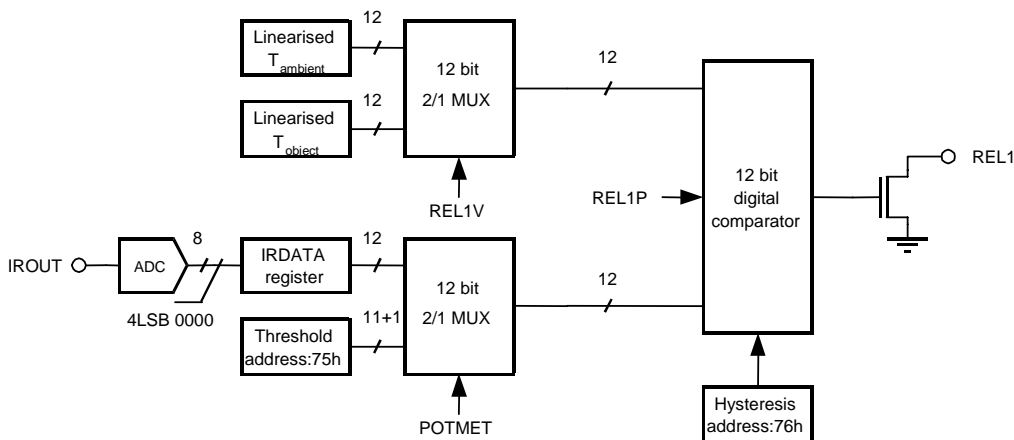

Comparator2 (REL1 pin) Configuration diagram

After the temperature data is updated in TOUT and IROUT registers (the current Ta&To are calculated) the main state machine will enable the comparator functions of the chip if one of them is enabled. Threshold data for both outputs is stored in addresses 73h (for Comp1) and 74h (for Rel1) in eeprom.

The threshold data can be calculated by the formula:

$$\text{Threshold value} = \frac{T_{thr} - T_{\min}}{T_{\max} - T_{\min}} \times 2048.$$

where:  $T_{thr}$  is the target temperature for the comparator  
 $T_{\min}$ ,  $T_{\max}$  are the minimum and maximum temperature under calibration.

The hysteresis value can be calculated by following formula:

$$\text{Hysteresis value} = \frac{Thys}{T_{\max} - T_{\min}} \times 2048$$

where:  $Thys$  is the desired hysteresis in deg C.  
 $T_{\min}$ ,  $T_{\max}$  are the minimum and maximum temperature under calibration

Both formulas are valid for ambient and IR temperatures. The data for hysteresis must be stored at addresses 74h (for Comp1) and 76h (for Rel1) after adding the hamming bits in the 5 least significant bit places. Refer to Hamming Coding in eeprom description section for details.

### Pulse Width Modulation

The PWM signal has a period of 102.4ms typical consisting of 2048 clock cycles of 50µs. Every frame starts with a leading buffer time,  $t_1$ , during which the signal is always high, as shown in the figure below. The leading buffer time is followed by a slot for the useful data signal,  $t_2$  and  $t_3$ , where the ration  $t_2/(t_2+t_3)$  is the representation of the output value.  $t_4$  is a slot for signaling of special conditions, such as out of range measurement of the sensor temperature,  $T_{\text{ambient}}$  and the occurrence of a fatal EEprom error, i.e. an error that can no longer be corrected automatically by the ECC circuitry of MLX90313.

Error signaling band		
Condition	Duty cycle	nominal timing
OVH: Tambient overflow	68.75 %	70.4 ms
OVL: Tambient underflow	75 %	76.8 ms
FE: Fatal Error EEprom	81.25%	83.2 ms

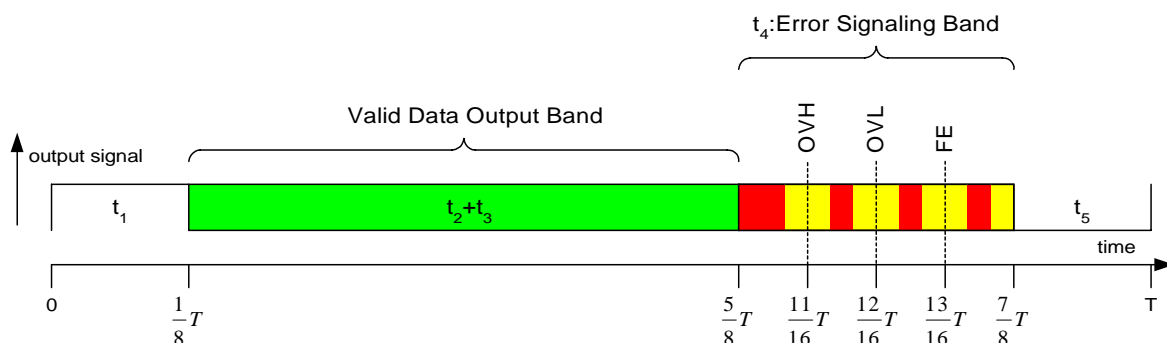

### Serial Interface

#### Protocol

The digital interface implemented in MLX90313 is SPI compatible. It can be used to access the on-chip EEPROM and all internal registers. The chip will always work as a slave device. The format of any

command is always 32 bits: 8 bits for the operation code, 8 bits for the address and 16 bits of data. The communication protocol is presented below.

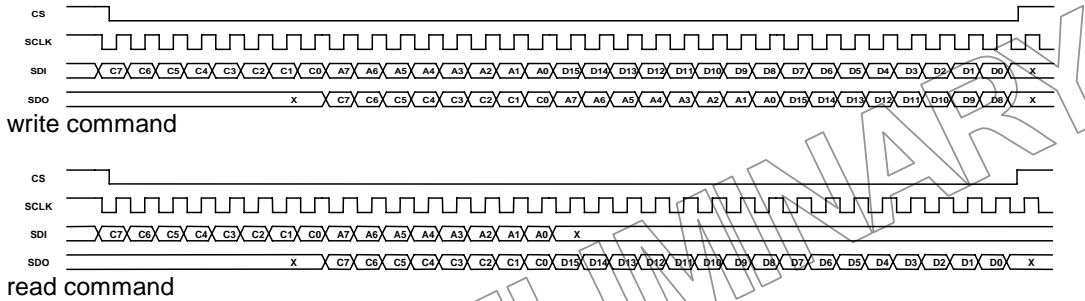

Every write command starts with a high to low transition of CS and ends by a low to high transition of CS after 32 periods of the serial data clock (SCLK). MLX90313 reads the data present on SDI on the rising edge of the clock. With a delay of 8 periods of the serial clock, the SPI will repeat the opcode, address and the first 8 bits of data on pin SDO. This allows the external master to check command and address and terminate the operation in case of an error by forcing CS high before the end of the complete command cycle, i.e. before the end of the 32 clock periods.

The read command is build up similarly, except that no data has to be passed of course. On SDO the opcode will be followed directly by the requested data, the address is not returned in this case.

The data on SDO is valid on the rising edge of the clock. In case of a read command, the SPI output will be valid on SDO starting on the 17<sup>th</sup> rising edge of the clock (after CS low) as indicated in the figure above.

### Timing/speed

The bit-rate depends on the serial data clock (SCLK) supplied by the master controller and is limited to 125kb/s. The timing requirements are given in the figure and table below

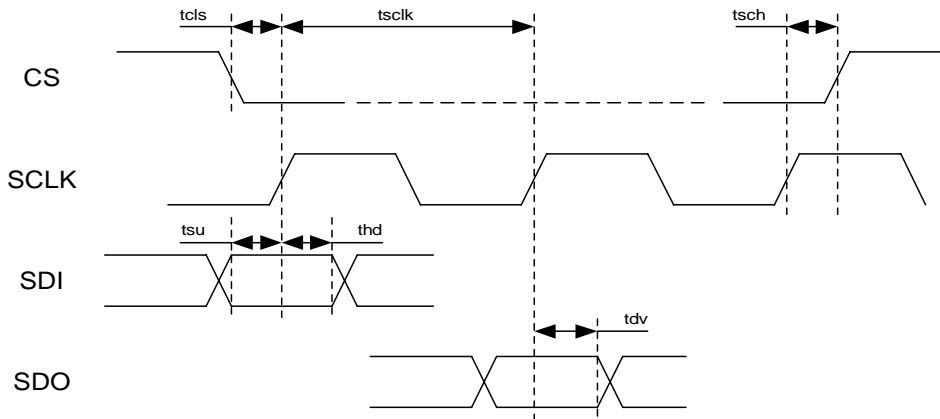

SPI timing requirements			
Symbol	Parameter	Value	Unit
tclk	Sclk period	min 8	µs
tcls	CS low to SCLK high	min 50	ns
tsch	SCLK low to CS high	min 50	ns
tsu	data in setup time	min 200	ns
thd	data in hold time	min 200	ns

tdv	data out valid	min 1	μs
-----	----------------	-------	----

### operation codes

The operation code is the first series of 8bits in a command, C[7:0] in the figure on the protocol above. Below table summarizes the operations available in MLX90313.

Operation Codes									
mnem.	C[7:0]								Command
WR	X	1	0	1	X	0	X	X	Write internal register
RD	X	1	0	0	1	0	X	X	Read internal register
WEPR	0	0	0	1	X	X	X	X	Write Eeprom
ER	0	0	1	X	X	X	X	X	Erase EEprom
REPR	X	0	0	0	1	X	X	X	Read Eeprom
BLWR	1	0	0	1	X	X	X	X	Block Write Eeprom
BLER	1	0	1	X	X	X	X	X	Block erase Eeprom

**Applications Information**

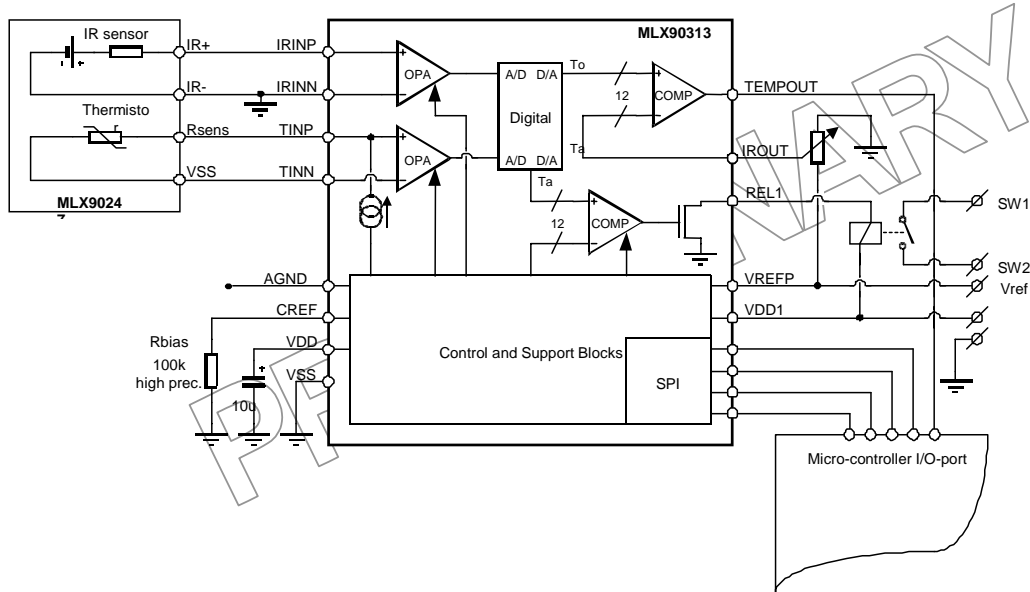

Typical application diagram

In the above application diagram, a simple thermometer with alarm function is depicted. As external components there are only a thermopile (like the MLX90247x) and a current setting resistor is used. Because the current needs to be constant over temperature and time, it is advised to use a precision resistor. The tempout pin is the output of a comparator which compares the measured object temperature with the threshold set by the external potentiometer. The second comparator operates the relay. It compares the ambient temperature with a fixed threshold programmed in eeprom. Both ambient and object temperatures can be read continuously by the microprocessor using the SPI interface.

For more application examples, take a look at our MLX90601 Infrared thermometer module, which incorporates a MLX90247 thermopile sensor and the MLX90313 IR sensor interface.

### Support Tools

In a short time Melexis will provide a demo board which can demonstrate all MLX90313's features. This will come with software which allows easy configuration of the MLX90313. Please have a look at [www.melexis.com](http://www.melexis.com) for latest info.

### ESD Precautions

Electronic semiconductor products are sensitive to Electro Static Discharge (ESD). Always observe Electro Static Discharge control procedures whenever handling semiconductor products.

### FAQ

Q: When is the MLX90313 available ?

A: Currently Melexis only delivers the MLX90313 as part of the MLX90601x Infrared Thermometer module. Please refer to MLX90601 datasheet for details. Samples can be obtained Q3/2001, full production starts Q4/2001.

### Glossary of Terms

ADC	Analog-to-digital converter
Ambient Compensation	The IR signal captured by a thermopile sensor is not only dependent on the temperature of the object (T <sub>object</sub> ) but also on the temperature of the sensor itself. Therefore the IR signal is compensated for this effect by means of the measured sensor temperature (T <sub>ambient</sub> ). This rather complex calculation is performed in the linearisation unit of MLX90313.
ASIC	application specific integrated circuit
Band-gap	Circuit to generate accurate absolute voltages. Usually they are independent of temperature and supply voltage, like the one used in the MLX90313
Chopper compensated amplifier	Special amplifier configuration aimed at ultra low offset
DAC	Digital-to-analog converter
Differential nonlinearity (DNL)	The deviation of any code from an ideal 1 LSB step
ECC	Error Checking and Correction
Eeprom	non-volatile memory that can be electrically erased and rewritten. This type of memory is used to store configuration and calibration data needed by the MLX90313.
Hamming coding	By giving a message a extra number of bits (= so called hamming bits), one can not only detect, but also correct a error that occurs in the stored data or the hamming bits. The eeprom memory of the MLX90313 uses hamming coding to do a error check and correction if needed and possible.
Integral nonlinearity (INL)	This is the maximum deviation from the ideal output curve and the actual output
IR	Infrared. Every object emits infrared radiation in relation to its temperature. This effect can be used to measure this temperature without the need for physical contact.
Linearisation	The signal from a thermopile is not linear with the object temperature. MLX90313 is therefore equipped with a digital calculation unit that produces an output that is linear with the object temperature.
LSB,MSB	Least Significant Bit, Most Significant Bit
NTC	See Thermistor.
PGA	Programmable gain amplifier.



POR	power –on reset: reset circuit that starts the digital system in a known state whenever the supply voltage is cycled
PSSR	Power Supply Rejection Ratio: Measure for an amplifier's immunity to disturbances on the supply connections.
PTC	See Thermistor.
SPI	Serial Peripheral Interface. Commonly used 4 wire serial link to connect different circuits over a short distance.
Ta, Tambient, ambient temperature Thermistor	The temperature of the IR sensor.  Temperature dependant resistor. Basically there are 2 types. The types that increase their resistance with rising temperature are PTC (positive thermal coefficient) type. The ones that decrease their resistance with rising temperature we call NTC (negative thermal coefficient) type. The MLX90313 can work with both types.
Tobject, To and Target Temperature	commonly used terms in infrared thermometry. It refers to the temperature of the target, at which the IR sensor is "looking"

## **Disclaimer**

Melexis reserves the right to periodically make modifications to product specifications. The information included herein is believed to be accurate and reliable. However, Melexis assumes no responsibility for its use; nor for any infringements of patents or other rights of third parties which may result from its use.

PRELIMINARY

**Physical Characteristics**

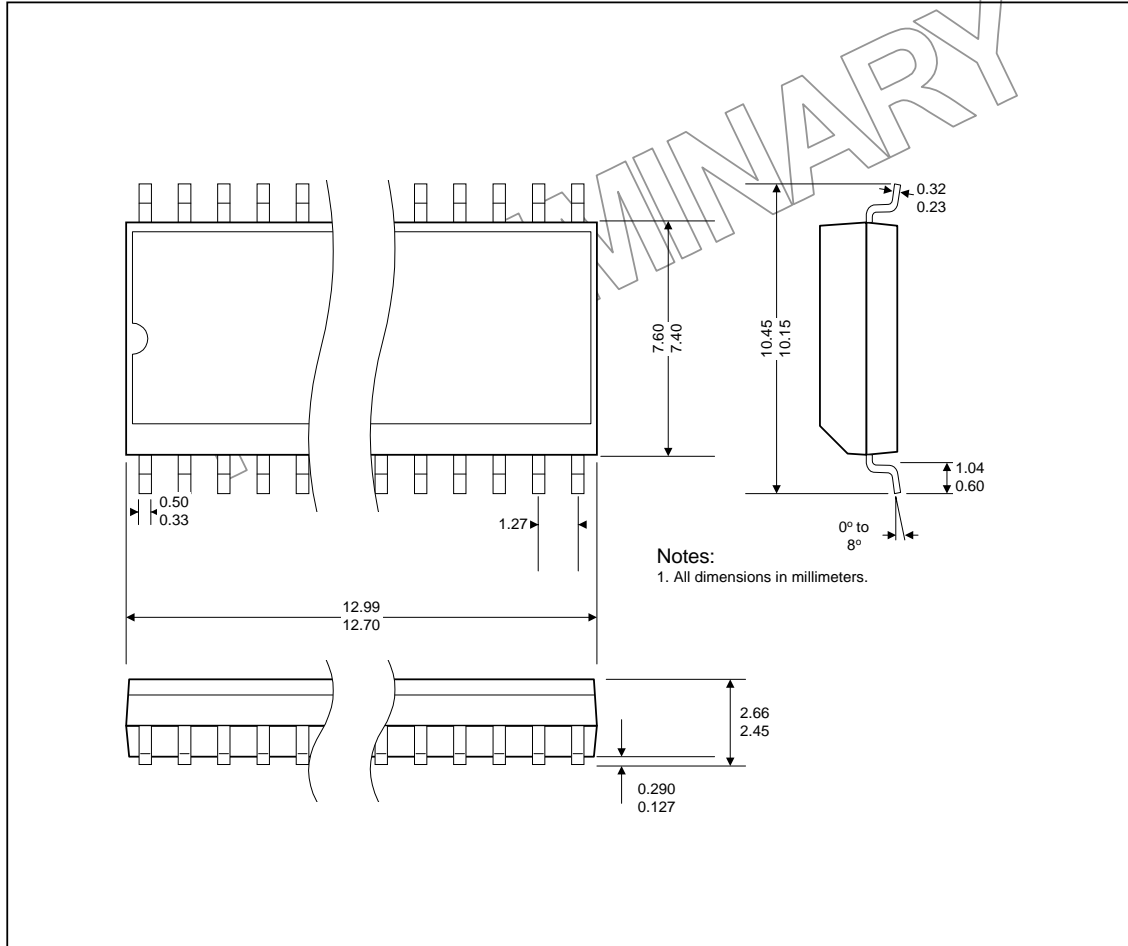

For the latest version of this document, go to our website at:  
**www.melexis.com**

Or for additional information contact Melexis Direct:

<b>Europe and Japan:</b>	<b>All other locations:</b>
Phone: +32 13 61 16 31	Phone: +1 603 223 2362
E-mail: sales_europe@melexis.com	E-mail: sales_usa@melexis.com