

# Product Information

## Navigation Gyroscope

### MLX90609-N2

The MLX90609-N2 Angular Rate Sensor is a full gyroscopic system. A single SMD package contains a high performance Silicon micromachined sensor with signal conditioning circuitry. It operates from 5V supply and is designed for dead reckoning navigation applications.

The MLX90609-N2 delivers two output signals proportional to the angular rate parallel to the assembly surface. One of the output signals is in an analog voltage format (the output is 2.5V at zero angular rate and the full scale angular rate produces an output of 4.5V or 0.5V depending on direction of rotation) and the other one is in a digital SPI format..

### Features

- High resolution and dynamic range
- Both digital (SPI) and analog outputs
- Low acceleration and angular rate cross sensitivity
- Low zero rate output drift
- Cost effective and compact solution
- High-performance MEMS sensor in mono crystalline Si yielding a superior long-term behavior reliability and dynamic range
- Programmable bandwidth
- Built-in on demand and non disruptive continuous self tests
- Factory set full scale range ( $\pm 75^\circ/\text{s}$ )
- On chip EEPROM calibration
- Serial Number in EEPROM
- Small footprint (SMD CLCC32) with horizontal mounting
- Operating temperature range:  $-40^\circ\text{C}$  to  $85^\circ\text{C}$

### Applications

- Navigation (dead reckoning)
- Robots

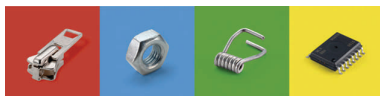

Small things make a big difference.

**Melexis**  
Microelectronic Integrated Systems

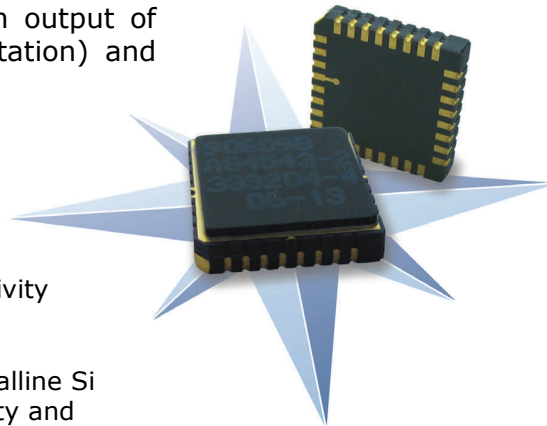

Automotive ICs

RF & RFID

Intelligent Drivers  
and Actuators

Silicon MEMS

Hall ICs

CMOS Imaging

Bus ICs

IR Temperature

## Application Circuitry

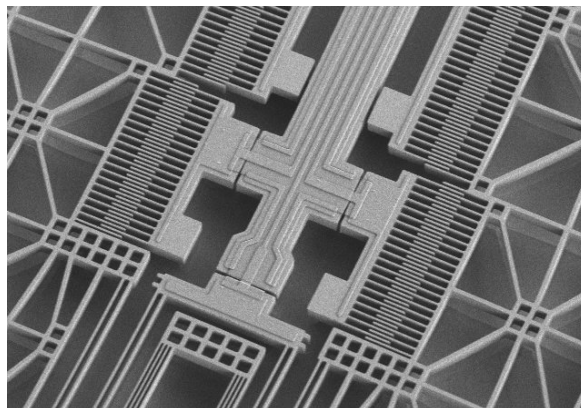
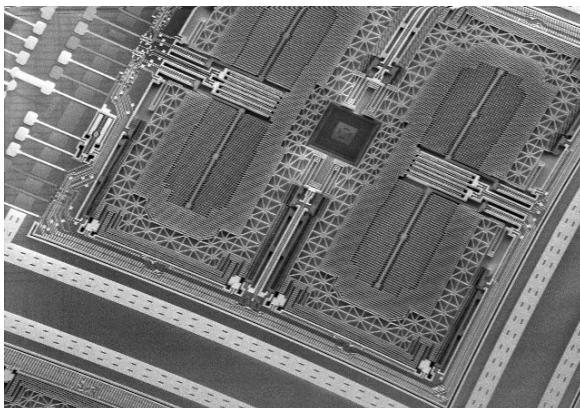
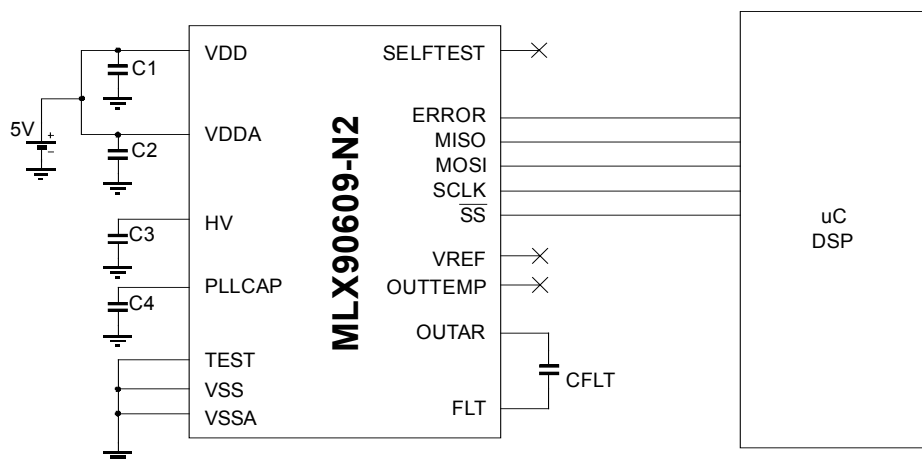

### Disclaimer:

Devices sold by Melexis are covered by the warranty and patent indemnification provisions appearing in its Term of Sale. Melexis makes no warranty, express, statutory, implied, or by description regarding the information set forth herein or regarding the freedom of the described devices from patent infringement. Melexis reserves the right to change specifications and prices at any time and without notice. Therefore, prior to designing this product into a system, it is necessary to check with Melexis for current information. This product is intended for use in normal commercial applications. Applications requiring extended temperature range, unusual environmental requirements, or high reliability applications, such as military, medical life-support or life-sustaining equipment are specifically not recommended without additional processing by Melexis for each application. The information furnished by Melexis is believed to be correct and accurate. However, Melexis shall not be liable to recipient or any third party for any damages, including but not limited to personal injury, property damage, loss of profits, loss of use, interrupt of business or indirect, special incidental or consequential damages, of any kind, in connection with or arising out of the furnishing, performance or use of the technical data herein. No obligation or liability to recipient or any third party shall arise or flow out of Melexis' rendering of technical or other services. © 2006 Melexis NV. All rights reserved.

Email Europe and rest of the world:  
sales\_europe@melexis.com

Email USA :  
sales\_usa@melexis.com

Email Asia:  
sales\_asia@melexis.com

For additional information go to our website at:

[www.melexis.com](http://www.melexis.com)

**Melexis**  
Microelectronic Integrated Systems