

Features and Benefits

- Rotary Position Gear Tooth Sensor
- Short Circuit Protection
- On-chip 10 bit A/D Converter
- Self-Adjusting Magnetic Range
- High Speed Operation
- No Chopper Delay
- Zero Speed Detection
- No Rotary Orientation Concerns

Applications

- Camshaft Sensor
- Geartooth Sensor
- Linear Encoder
- Rotary Encoder
- Direction Detection*

*See applications example

Ordering Information

Part No.	Temperature Suffix	Package Code
MLX90217	L (-40°C to 150°C)	UA (TO-92 flat)

Functional Diagram

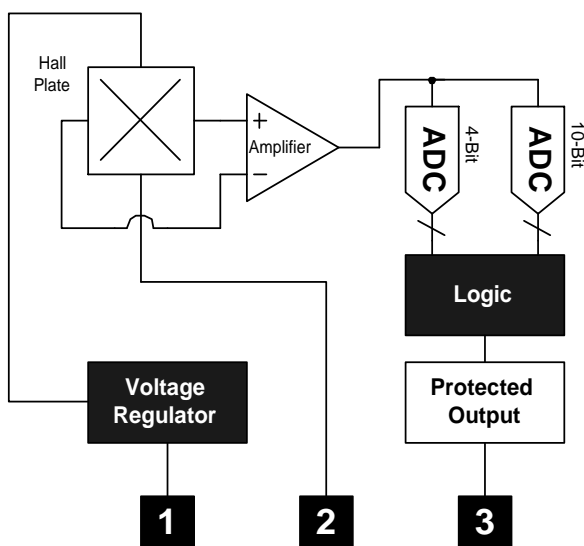

Pin 1 - V_{DD} (Supply)
 Pin 2 - V_{SS} (Ground)
 Pin 3 - Output

Note: Static sensitive device, please observe ESD precautions.

Description

The MLX90217 is a self adjusting digital output rotary position gear tooth sensor designed for use in automotive camshaft sensing as well as other speed sensing applications. It is designed to be used with a bias magnet south facing the back (non-marked) side of the IC. The device has an open collector output which is short circuit protected.

The MLX90217 is a sophisticated IC featuring an on-chip 10-bit A/D Converter and logic that acts as a digital sample and hold circuit. A separate 4-bit A/D converter provides a fixed hysteresis. The 90217 does not have a chopper delay. The 90217 uses a single Hall plate which is immune to rotary alignment problems. The bias magnet can be from 50 to 400mT.

As the signal is sampled, the logic recognizes an increasing or decreasing flux density. The output will turn on (BOP) after the flux has reached its peak and decreased by an amount equal to the hysteresis. Similarly the output will turn off (BOP) after the flux has reached its minimum value and increased by an amount equal to the hysteresis.

MLX90217 Electrical Specifications

DC Operating Parameters $T_A = -40^{\circ}\text{C}$ to 150°C , $V_{DD} = 3.5\text{V}$ to 24V (unless otherwise specified).

Parameter	Symbol	Test Conditions	Min	Typ	Max	Units
Supply Voltage	V_{DD}	Operating	3.5	-	24	V
Supply Current	I_{DD}	$V_{DD} = 12\text{V}$	1.5	3.0	4.5	mA
Supply Current	I_{DD}	$V_{DD} = 3.5\text{V}$ to 24V	1	-	6	mA
Leakage Current	I_{LEAK}	$V_{OUT} = 3.5\text{V}$ to 24V	-	-	10	μA
Output Current	I_{OUT}	Operating	-	-	25	mA
Output Saturation Voltage	V_{SAT}	$V_{DD} = 12\text{V}$, $I_{OUT} = 25\text{mA}$	-	-	600	mV
Output Short Circuit Current	I_{FAULT}	Fault	50	100	150	mA
Output Short Circuit Shutdown	T_{FAULT}	Fault	100	-	200	μS
Clock Frequency	f_{CLK}	Operating	300	500	800	kHz
Output Rise Time	t_r	$V_{DD}=12\text{V}$ $R_1 = 880\Omega$ $C_1 = 20\text{pf}$	-	-	400	nS
Output Fall Time	t_f	$V_{DD}=12\text{V}$ $R_1 = 880\Omega$ $C_1 = 20\text{pf}$	-	-	400	nS
Bandwidth	BW	Operating	-	-	15	kHz
Thermal Resistance	R_{TH}	Operating	-	-	200	$^{\circ}\text{C}/\text{Watt}$

MLX90217 Magnetic Specifications

DC Operating Parameters $T_A = -40^{\circ}\text{C}$ to 150°C , $V_{DD} = 3.5\text{V}$ to 24V (Unless otherwise specified)

Parameter	Symbol	Test Conditions	Min	Typ	Max	Units
Back Bias Range	B_{BIAS}	Operating	-30	-	400	mT
Linear Region		$V_{DD} = 12\text{V}$	50	-	500	mT
Hysteresis	B_{hys}	$V_{DD} = 3.5\text{V}$ to 24V	1.8	3.5	10	mT

Notes: $1\text{mT}=10\text{Gauss}$

Performance Graphs

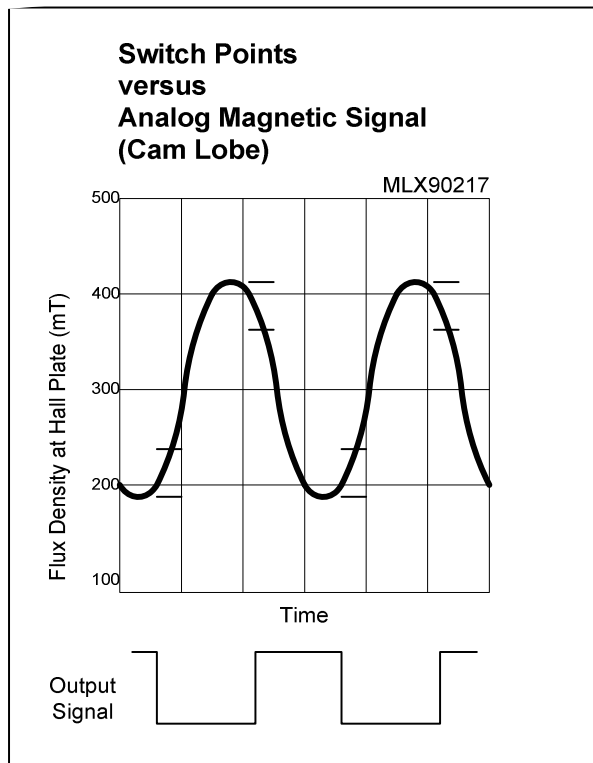
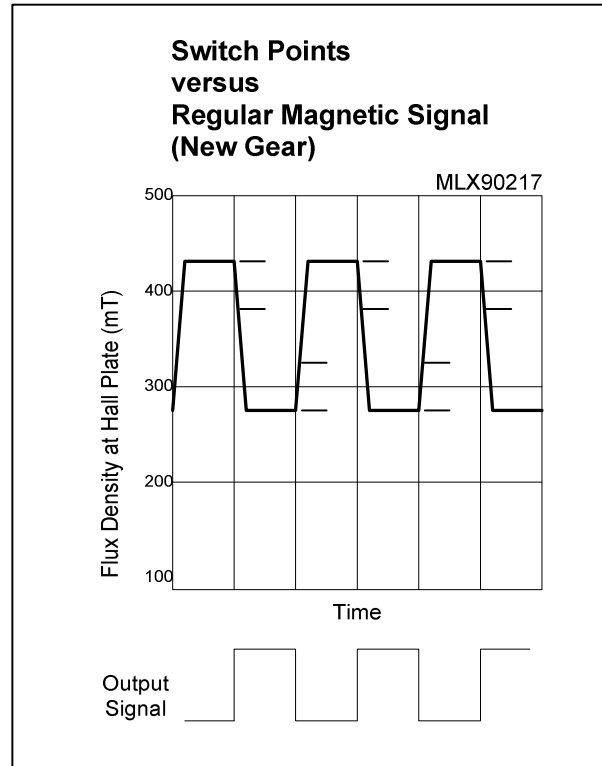
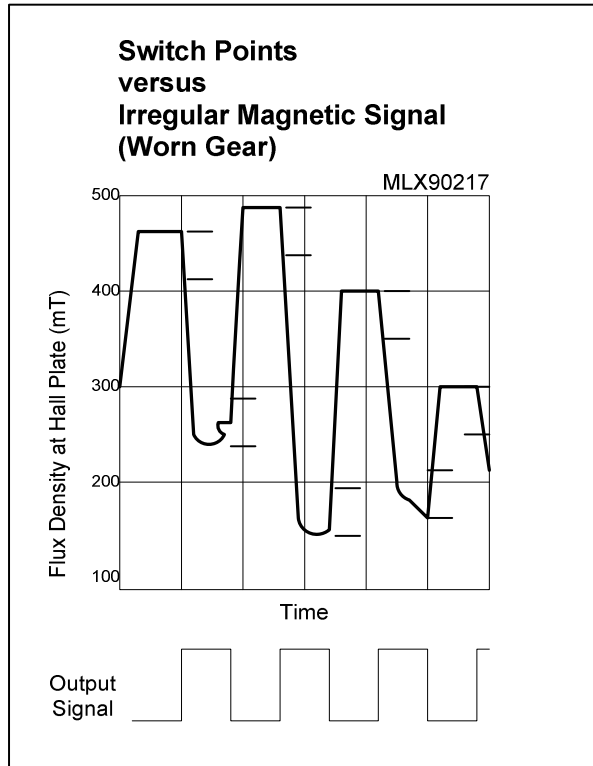

Absolute Maximum Ratings

Supply Voltage (Operating), V_{DD}	30V
Supply Current (Fault), I_{DD}	50mA
Output Current (Fault), I_{OUT}	30mA
Output Current (Fault), I_{fault}	50mA
Output Voltage, V_{OUT}	30V
Power Dissipation, P_D	100mW
Operating Temperature Range, T_A	- 40°C to 150°C
Storage Temperature Range, T_S	- 65°C to 150°C
Maximum Junction Temp, T_J	175°C

Application Notes

Maximum dynamic range is 500 mT. The hysteresis is fixed at 5.0 mT. Best angular accuracy will be obtained when the magnetic circuit provides peak magnetic flux at the chip near the high end of the linear range of 500 mT. EMC protection using external components are recommended. Two possibilities are shown on the following page. Normally the South pole faces the unbranded side of the device. A North pole will enable a test sequence used in factory testing.

Unique Features

The output is reset to the high state at power on (output driver is off) whatever the field is. The output only changes after the first min is detected. The reset state holds no information about the field. If the supply of the chip is raised slowly, the reset state is not stable. This has been observed at 0 field but it should be the same with small and large fields.

Gear tooth sensors often need to be adjusted after the module is assembled to align the magnet with differential Hall plates or orient with teeth. However the MLX90217 is "self adjusting" over a wide range of back bias flux eliminating the need for any trimming in the application. The magnet may be glued to the back surface (non branded side) of the IC using a cyanoacrylate adhesive or suitable epoxy.

Applications Examples

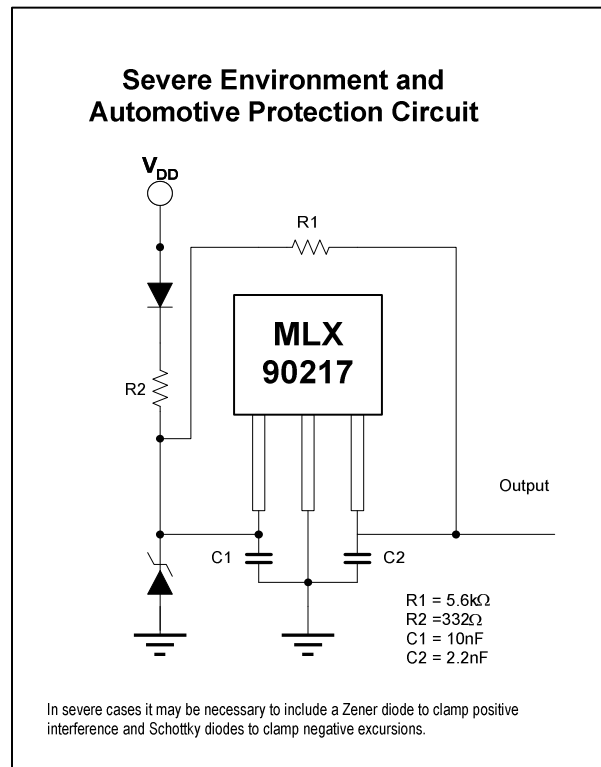
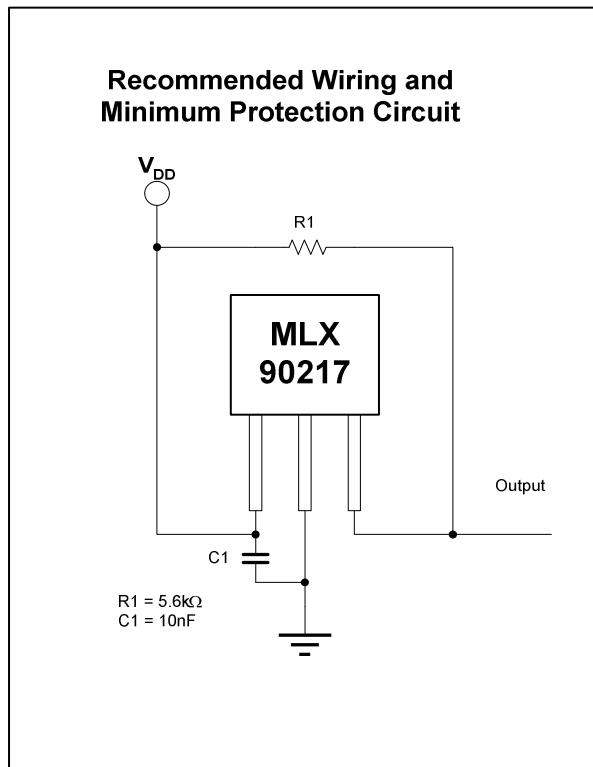
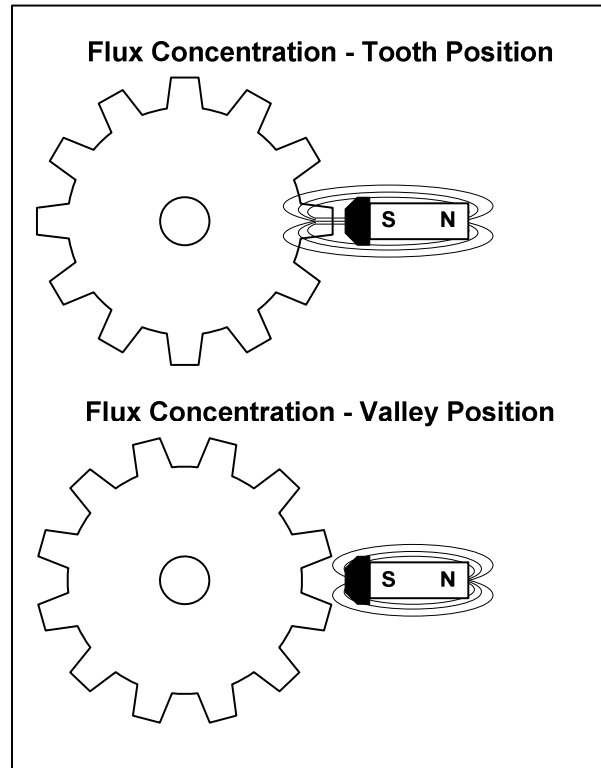
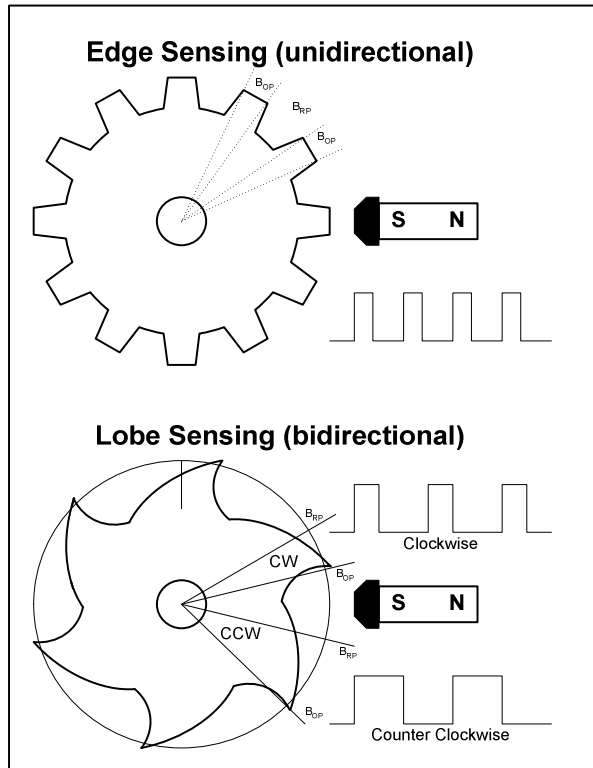

Physical Characteristics

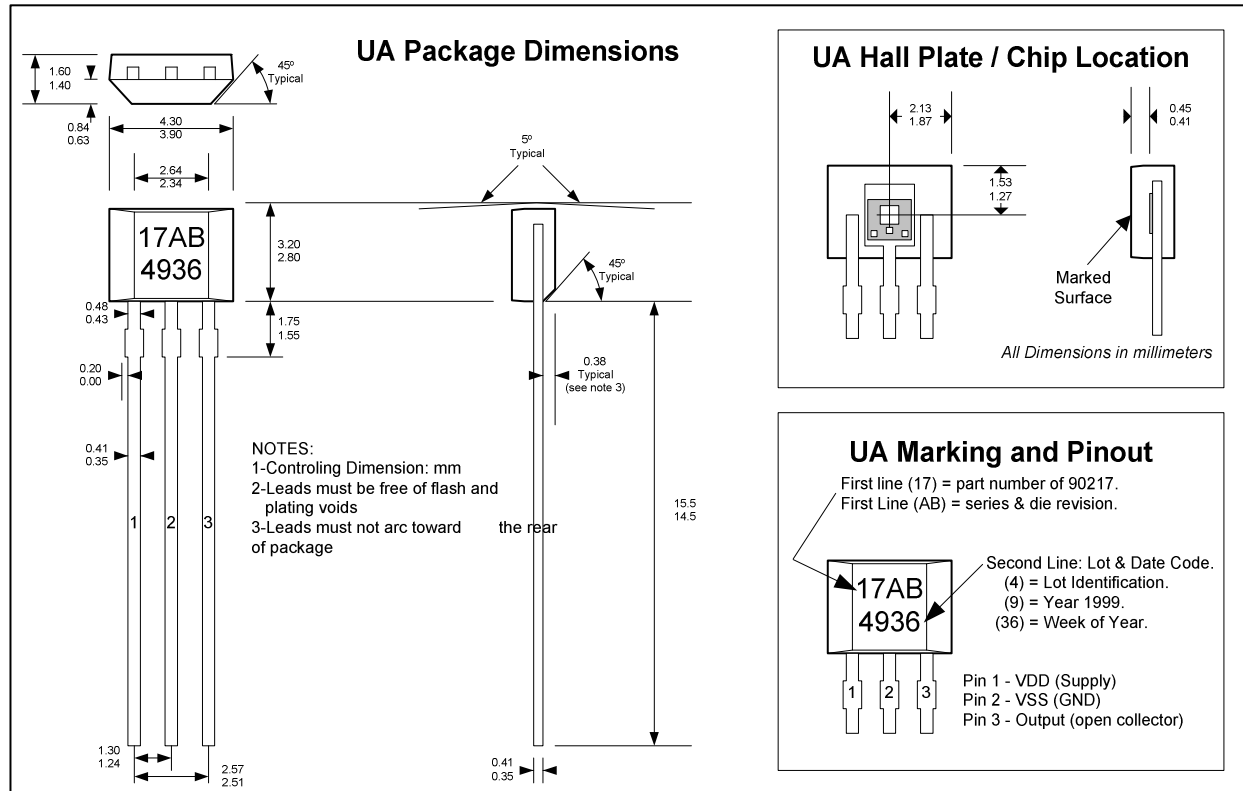

Reliability Information

This Melexis device is classified and qualified regarding soldering technology, solderability and moisture sensitivity level, as defined in this specification, according to following test methods:

- IPC/JEDEC J-STD-020
Moisture/Reflow Sensitivity Classification For Nonhermetic Solid State Surface Mount Devices
(classification reflow profiles according to table 5-2)
- EIA/JEDEC JESD22-A113
Preconditioning of Nonhermetic Surface Mount Devices Prior to Reliability Testing
(reflow profiles according to table 2)
- CECC00802
Standard Method For The Specification of Surface Mounting Components (SMDs) of Assessed Quality
- EIA/JEDEC JESD22-B106
Resistance to soldering temperature for through-hole mounted devices
- EN60749-15
Resistance to soldering temperature for through-hole mounted devices
- MIL 883 Method 2003 / EIA/JEDEC JESD22-B102
Solderability

For all soldering technologies deviating from above mentioned standard conditions (regarding peak temperature, temperature gradient, temperature profile etc) additional classification and qualification tests have to be agreed upon with Melexis.

The application of Wave Soldering for SMD's is allowed only after consulting Melexis regarding assurance of adhesive strength between device and board.

Based on Melexis commitment to environmental responsibility, European legislation (Directive on the Restriction of the Use of Certain Hazardous substances, RoHS) and customer requests, Melexis has installed a Roadmap to qualify their package families for lead free processes also.

Various lead free generic qualifications are running, current results on request.

For more information on manufacturability/solderability see quality page at our website:
<http://www.melexis.com/html/pdf/MLXleadfree-statement.pdf>

ESD Procautions

Electronic semiconductor products are sensitive to Electro Static Discharge (ESD). Always observe Electro Static Discharge control procedures whenever handling semiconductor products.

Disclaimer

Devices sold by Melexis are covered by the warranty and patent indemnification provisions appearing in its Term of Sale. Melexis makes no warranty, express, statutory, implied, or by description regarding the information set forth herein or regarding the freedom of the described devices from patent infringement. Melexis reserves the right to change specifications and prices at any time and without notice. Therefore, prior to designing this product into a system, it is necessary to check with Melexis for current information. This product is intended for use in normal commercial applications. Applications requiring extended temperature range, unusual environmental requirements, or high reliability applications, such as military, medical life-support or life-sustaining equipment are specifically not recommended without additional processing by Melexis for each application.

The information furnished by Melexis is believed to be correct and accurate. However, Melexis shall not be liable to recipient or any third party for any damages, including but not limited to personal injury, property damage, loss of profits, loss of use, interrupt of business or indirect, special incidental or consequential damages, of any kind, in connection with or arising out of the furnishing, performance or use of the technical data herein. No obligation or liability to recipient or any third party shall arise or flow out of Melexis' rendering of technical or other services.

© 2002 Melexis NV. All rights reserved.

For the latest version of this document, go to our website at:

www.melexis.com

Or for additional information contact Melexis Direct:

Europe and Japan:

Phone: +32 13 67 04 95
E-mail: sales_europe@melexis.com

All other locations:

Phone: +1 603 223 2362
E-mail: sales_usa@melexis.com

ISO/TS16949 and ISO14001 Certified