

This datasheet is applicable to all revision 3 chips

The QT100 charge-transfer ('QT') touch sensor is a self-contained digital IC capable of detecting near-proximity or touch. It will project a touch or proximity field through any dielectric like glass, plastic, stone, ceramic, and even most kinds of wood. It can also turn small metal-bearing objects into intrinsic sensors, making them responsive to proximity or touch. This capability, coupled with its ability to self-calibrate, can lead to entirely new product concepts.

It is designed specifically for human interfaces, like control panels, appliances, toys, lighting controls, or anywhere a mechanical switch or button may be found.

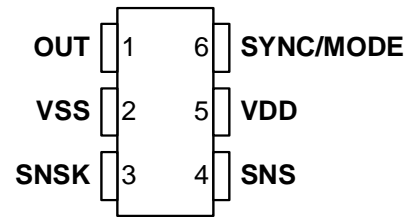

AT A GLANCE

Number of keys:	One
Technology:	Patented spread-spectrum charge-transfer (direct mode)
Key outline sizes:	6mm x 6mm or larger (panel thickness dependent); widely different sizes and shapes possible
Electrode design:	Solid or ring electrode shapes
Layers required:	One
Electrode materials:	Etched copper, silver, carbon, Indium Tin Oxide (ITO), Orgacon† ink
Electrode Substrates:	PCB, FPCB, plastic films, glass
Panel materials:	Plastic, glass, composites, painted surfaces (low particle density metallic paints possible)
Panel thickness:	Up to 50mm glass, 20mm plastic (electrode size dependent)
Key sensitivity:	Settable via capacitor
Interface:	Digital output, active high
Moisture tolerance:	Good
Power:	2V ~ 5V
Package:	6-pin SOT23-6 RoHS compliant
Signal processing:	Self-calibration, auto drift compensation, noise filtering
Applications:	Control panels, consumer appliances, toys, lighting controls, mechanical switch or button
Patents:	QTouch™ (patented Charge-transfer method) HeartBeat™ (monitors health of device)

† Orgacon is a registered trademark of Agfa-Gevaert N.V

AVAILABLE OPTIONS

T_A	SOT23-6
-40°C to +85°C	QT100-ISG

Contents

1 Overview	3	2.9 Output Features	5
1.1 Introduction	3	2.9.1 Output	5
1.2 Basic Operation	3	2.9.2 HeartBeat™ Output	5
1.3 Electrode Drive	3	2.9.3 Output Drive	6
1.4 Sensitivity	3	3 Circuit Guidelines	6
1.4.1 Introduction	3	3.1 Application Note	6
1.4.2 Increasing Sensitivity	3	3.2 Sample Capacitor	6
1.4.3 Decreasing Sensitivity	3	3.3 Power Supply, PCB Layout	6
2 Operation Specifics	3	4 Specifications	7
2.1 Run Modes	3	4.1 Absolute Maximum Specifications	7
2.1.1 Introduction	3	4.2 Recommended Operating Conditions	7
2.1.2 Fast Mode	3	4.3 AC Specifications	7
2.1.3 Low Power Mode	3	4.4 Signal Processing	7
2.1.4 SYNC Mode	4	4.5 DC Specifications	8
2.2 Threshold	4	4.6 Mechanical Dimensions	8
2.3 Max On-duration	4	4.7 Marking	9
2.4 Detect Integrator	4	4.8 Moisture Sensitivity Level (MSL)	9
2.5 Forced Sensor Recalibration	5	5 Datasheet Control	10
2.6 Drift Compensation	5	5.1 Changes	10
2.7 Response Time	5	5.2 Numbering Convention	10
2.8 Spread Spectrum	5		

1 Overview

1.1 Introduction

The QT100 is a digital burst mode charge-transfer (QT) sensor designed specifically for touch controls; it includes all hardware and signal processing functions necessary to provide stable sensing under a wide variety of changing conditions. Only a single low cost, noncritical capacitor is required for operation.

Figure 1.1 shows a basic circuit using the device.

1.2 Basic Operation

The QT100 employs bursts of charge-transfer cycles to acquire its signal. Burst mode permits power consumption in the microamp range, dramatically reduces RF emissions, lowers susceptibility to EMI, and yet permits excellent response time. Internally the signals are digitally processed to reject impulse noise, using a 'consensus' filter which requires four consecutive confirmations of a detection before the output is activated.

The QT switches and charge measurement hardware functions are all internal to the QT100.

1.3 Electrode Drive

For optimum noise immunity, the electrode should only be connected to SNSK.

In all cases the rule $C_s \gg C_x$ must be observed for proper operation; a typical load capacitance (C_x) ranges from 5-20pF while C_s is usually about 2-50nF.

Increasing amounts of C_x destroy gain, therefore it is important to limit the amount of stray capacitance on both SNS terminals. This can be done, for example, by minimizing trace lengths and widths and keeping these traces away from power or ground traces or copper pours.

The traces and any components associated with SNS and SNSK will become touch sensitive and should be treated with caution to limit the touch area to the desired location.

A series resistor, R_s , should be placed in line with SNSK to the electrode to suppress ESD and EMC effects.

1.4 Sensitivity

1.4.1 Introduction

The sensitivity on the QT100 is a function of things like the value of C_s , electrode size and capacitance, electrode shape and orientation, the composition and aspect of the object to be sensed, the thickness and composition of any overlaying panel material, and the degree of ground coupling of both sensor and object.

1.4.2 Increasing Sensitivity

In some cases it may be desirable to increase sensitivity; for example, when using the sensor with very thick panels having a low dielectric constant. Sensitivity can often be increased by using a larger electrode or reducing panel thickness. Increasing electrode size can have diminishing returns, as high values of C_x will reduce sensor gain.

Figure 1.1 Basic Circuit Configuration

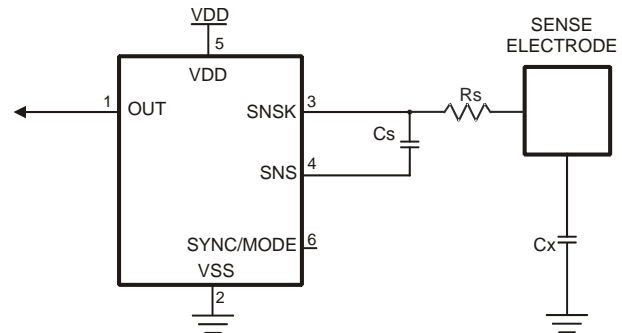

Note: A bypass capacitor should be tightly wired between Vdd and Vss and kept close to QT100 pin 5.

The value of C_s also has a dramatic effect on sensitivity, and this can be increased in value with the trade-off of slower response time and more power. Increasing the electrode's surface area will not substantially increase touch sensitivity if its diameter is already much larger in surface area than the object being detected. Panel material can also be changed to one having a higher dielectric constant, which will better help to propagate the field.

Ground planes around and under the electrode and its SNSK trace will cause high C_x loading and destroy gain. The possible signal-to-noise ratio benefits of ground area are more than negated by the decreased gain from the circuit, and so ground areas around electrodes are discouraged. Metal areas near the electrode will reduce the field strength and increase C_x loading and should be avoided, if possible. Keep ground away from the electrodes and traces.

1.4.3 Decreasing Sensitivity

In some cases the QT100 may be too sensitive. In this case gain can be easily lowered further by decreasing C_s .

2 Operation Specifics

2.1 Run Modes

2.1.1 Introduction

The QT100 has three running modes which depend on the state of SYNC, pin 6 (high or low).

2.1.2 Fast Mode

The QT100 runs in Fast mode if the SYNC pin is permanently high. In this mode the QT100 runs at maximum speed at the expense of increased current consumption. Fast mode is useful when speed of response is the prime design requirement. The delay between bursts in Fast mode is approximately 1ms, as shown in Figure 2.2.

2.1.3 Low Power Mode

The QT100 runs in Low Power (LP) mode if the SYNC line is held low. In this mode it sleeps for approximately 85ms at the end of each burst, saving power but slowing response. On detecting a possible key touch, it temporarily switches to Fast mode until either the key touch is confirmed or found to be spurious (via the detect integration process). It then returns to LP mode after the key touch is resolved as shown in Figure 2.1.

Figure 2.1 Low Power Mode (SYNC held low)

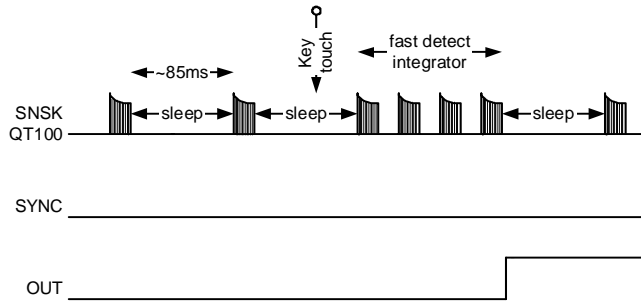

Figure 2.2 Fast Mode Bursts (SYNC held high)

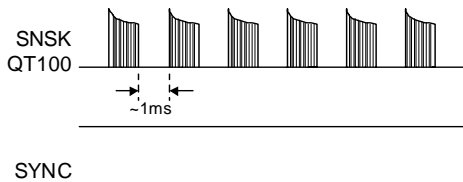

Figure 2.3 SYNC Mode (triggered by SYNC edges)

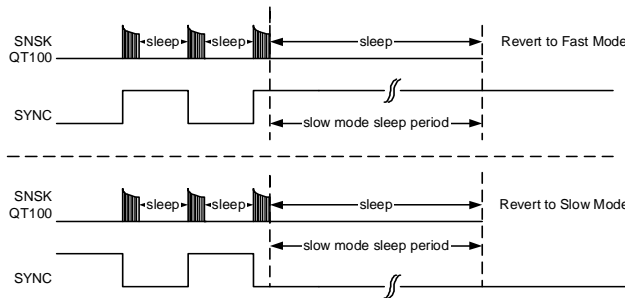
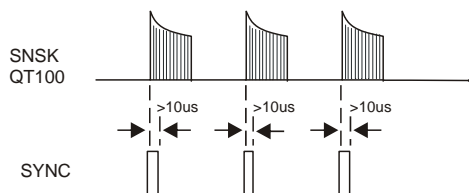

Figure 2.4 SYNC Mode (Short Pulses)



2.1.4 SYNC Mode

It is possible to synchronize the device to an external clock source by placing an appropriate waveform on the SYNC pin. SYNC mode can synchronize multiple QT100 devices to each other to prevent cross-interference, or it can be used to enhance noise immunity from low frequency sources such as 50Hz or 60Hz mains signals.

The SYNC pin is sampled at the end of each burst. If the device is in Fast mode and the SYNC pin is sampled high, then the device continues to operate in Fast mode (Figure 2.2). If SYNC is sampled low, then the device goes to sleep. From then on, it will operate in SYNC mode (Figure 2.1). Therefore, to guarantee entry into SYNC mode the low period of the SYNC signal should be longer than the burst length (Figure 2.3).

However, once SYNC mode has been entered, if the SYNC signal consists of a series of short pulses ($>10\mu\text{s}$) then a burst will only occur on the leading edge of each pulse (Figure 2.4) instead of on each change of SYNC signal, as normal (Figure 2.3).

In SYNC mode, the device will sleep after each measurement burst (just as in LP mode) but will be awakened by a change in the SYNC signal in either direction, resulting in a new measurement burst. If SYNC remains unchanged for a period longer than the LP mode sleep period (about 85ms), the device will resume operation in either Fast or LP mode depending on the level of the SYNC pin (Figure 2.3).

There is no DI in SYNC mode (each touch is a detection) but the Max On-duration will depend on the time between SYNC pulses; see Sections 2.3 and 2.4. Recalibration timeout is a fixed number of measurements so will vary with the SYNC period.

2.2 Threshold

The internal signal threshold level is fixed at 10 counts of change with respect to the internal reference level, which in turn adjusts itself slowly in accordance with the drift compensation mechanism.

The QT100 employs a hysteresis dropout of two counts of the delta between the reference and threshold levels.

2.3 Max On-duration

If an object or material obstructs the sense pad the signal may rise enough to create a detection, preventing further operation. To prevent this, the sensor includes a timer which monitors detections. If a detection exceeds the timer setting the sensor performs a full recalibration. This is known as the Max On-duration feature and is set to $\sim 80\text{s}$ (at 3V). This will vary slightly with C_s and if SYNC mode is used. As the internal timebase for Max On-duration is determined by the burst rate, the use of SYNC can cause dramatic changes in this parameter depending on the SYNC pulse spacing.

2.4 Detect Integrator

It is desirable to suppress detections generated by electrical noise or from quick brushes with an object. To accomplish this, the QT100 incorporates a 'detect integration' (DI) counter that increments with each detection until a limit is reached, after which the output is activated. If no detection is sensed prior to the final count, the counter is reset immediately to zero. In the QT100, the required count is four. In LP mode the device will switch to Fast mode temporarily in order to resolve the detection more quickly; after a touch is either confirmed or denied the device will revert back to normal LP mode operation automatically.

The DI can also be viewed as a 'consensus' filter, that requires four successive detections to create an output.

2.5 Forced Sensor Recalibration

The QT100 has no recalibration pin; a forced recalibration is accomplished when the device is powered up or after the recalibration timeout. However, supply drain is low so it is a simple matter to treat the entire IC as a controllable load; driving the QT100's V_{DD} pin directly from another logic gate or a microcontroller port will serve as both power and 'forced recal'. The source resistance of most CMOS gates and microcontrollers are low enough to provide direct power without problem.

2.6 Drift Compensation

Signal drift can occur because of changes in C_x and C_s over time. It is crucial that drift be compensated for, otherwise false detections, nondetections, and sensitivity shifts will follow.

Drift compensation (Figure 2.5). is performed by making the reference level track the raw signal at a slow rate, but only while there is no detection in effect. The rate of adjustment must be performed slowly, otherwise legitimate detections could be ignored. The QT100 drift compensates using a slew-rate limited change to the reference level; the threshold and hysteresis values are slaved to this reference.

Once an object is sensed, the drift compensation mechanism ceases since the signal is legitimately high, and therefore should not cause the reference level to change.

The QT100's drift compensation is 'asymmetric'; the reference level drift-compensates in one direction faster than it does in the other. Specifically, it compensates faster for decreasing signals than for increasing signals. Increasing signals should not be compensated for quickly, since an approaching finger could be compensated for partially or entirely before even approaching the sense electrode. However, an obstruction over the sense pad, for which the sensor has already made full allowance, could suddenly be removed leaving the sensor with an artificially elevated reference level and thus become insensitive to touch. In this latter case, the sensor will compensate for the object's removal very quickly, usually in only a few seconds.

With large values of C_s and small values of C_x, drift compensation will appear to operate more slowly than with the converse. Note that the positive and negative drift compensation rates are different.

Figure 2.5 Drift Compensation

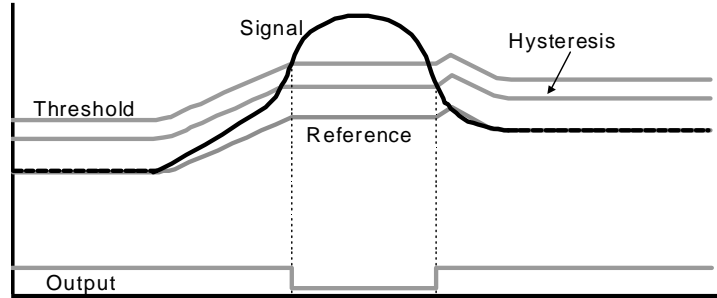

2.7 Response Time

The QT100's response time is highly dependent on run mode and burst length, which in turn is dependent on C_s and C_x. With increasing C_s, response time slows, while increasing levels of C_x reduce response time. The response time will also be a lot slower in LP or SYNC mode due to a longer time between burst measurements.

2.8 Spread Spectrum

The QT100 modulates its internal oscillator by ± 7.5 percent during the measurement burst. This spreads the generated noise over a wider band reducing emission levels. This also reduces susceptibility since there is no longer a single fundamental burst frequency.

2.9 Output Features

2.9.1 Output

The output of the QT100 is active-high upon detection. The output will remain active-high for the duration of the detection, or until the Max On-duration expires, whichever occurs first. If a Max On-duration timeout occurs first, the sensor performs a full recalibration and the output becomes inactive (low) until the next detection.

Figure 2.6

Getting HeartBeat pulses with a pull-up resistor

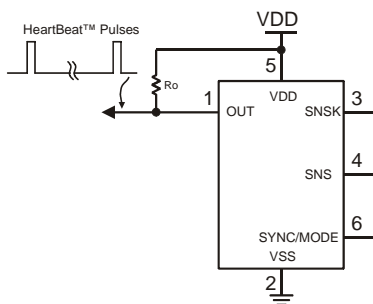
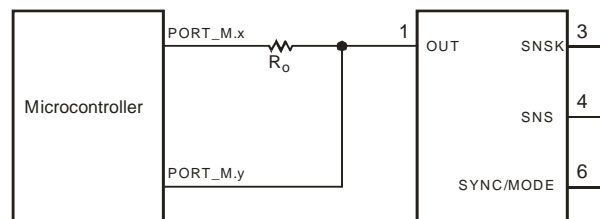

Figure 2.7

Using a micro to obtain HeartBeat pulses in either output state



2.9.2 HeartBeat™ Output

The QT100 output has a HeartBeat™ 'health' indicator superimposed on it in both LP and SYNC modes. This operates by taking the output pin into a three-state mode for 15µs once before every QT burst. This output state can be used to determine that the sensor is operating properly, or it can be ignored, using one of several simple methods.

The HeartBeat indicator can be sampled by using a pull-up resistor on the OUT pin, and feeding the resulting positive-going pulse into a counter, flip flop, one-shot, or other circuit. The pulses will only be visible when the chip is not detecting a touch.

If the sensor is wired to a microcontroller as shown in Figure 2.7, the microcontroller can reconfigure the load resistor to either V_{SS} or V_{DD} depending on the output state of the QT100, so that the pulses are evident in either state.

Electromechanical devices like relays will usually ignore the short Heartbeat pulse. The pulse also has too low a duty cycle to visibly affect LEDs. It can be filtered completely if desired, by adding an RC filter to the output, or if interfacing directly and only to a high-impedance CMOS input, by doing nothing or at most adding a small noncritical capacitor from OUT to V_{SS}.

2.9.3 Output Drive

The OUT pin is active high and can sink or source up to 2mA. When a large value of C_s (>20nF) is used the OUT current should be limited to <1mA to prevent gain-shifting side effects, which happen when the load current creates voltage drops on the die and bonding wires; these small shifts can materially influence the signal level to cause detection instability.

3 Circuit Guidelines

3.1 Application Note

Refer to Application Note AN-KD02, downloadable from the Quantum website for more information on construction and design methods. Go to <http://www.qprox.com>, click the Support tab and then Application Notes.

3.2 Sample Capacitor

C_s is the charge sensing sample capacitor. The required C_s value depends on the thickness of the panel and its dielectric constant. Thicker panels require larger values of C_s. Typical values are 2nF to 50nF depending on the sensitivity required; larger values of C_s demand higher stability and better dielectric to ensure reliable sensing.

The C_s capacitor should be a stable type, such as X7R ceramic or PPS film. For more consistent sensing from unit to unit, 5 percent tolerance capacitors are recommended. X7R ceramic types can be obtained in 5 percent tolerance at little or no extra cost. In applications where high sensitivity (long burst length) is required the use of PPS capacitors is recommended.

3.3 Power Supply, PCB Layout

The power supply can range between 2.0V and 5.5V. At 3V current drain averages less than 500µA in Fast mode.

If the power supply is shared with another electronic system, care should be taken to ensure that the supply is free of digital spikes, sags, and surges which can adversely affect the QT100. The QT100 will track slow changes in V_{DD}, but it can be badly affected by rapid voltage fluctuations. It is highly recommended that a separate voltage regulator be used just for the QT100 to isolate it from power supply shifts caused by other components.

If desired, the supply can be regulated using a Low Dropout (LDO) regulator, although such regulators often have poor transient line and load stability. See Application Note AN-KD02 (see Section 3.1) for further information on power supply considerations.

Parts placement: The chip should be placed to minimize the SNSK trace length to reduce low frequency pickup, and to reduce stray C_x which degrades gain. The C_s and R_s resistors (see Figure 1.1) should be placed as close to the body of the chip as possible so that the trace between R_s and the SNSK pin is very short, thereby reducing the antenna-like ability of this trace to pick up high frequency signals and feed them directly into the chip. A ground plane can be used under the chip and the associated discretes, but the trace from the R_s resistor and the electrode should not run near ground to reduce loading.

For best EMC performance the circuit should be made entirely with SMT components.

Electrode trace routing: Keep the electrode trace (and the electrode itself) away from other signal, power, and ground traces including over or next to ground planes. Adjacent switching signals can induce noise onto the sensing signal; any adjacent trace or ground plane next to, or under, the electrode trace will cause an increase in C_x load and desensitize the device.

Important Note: *for proper operation a 100nF (0.1µF) ceramic bypass capacitor must be used directly between V_{DD} and V_{SS}, to prevent latch-up if there are substantial V_{DD} transients; for example, during an ESD event. The bypass capacitor should be placed very close to the device's power pins.*

4 Specifications

4.1 Absolute Maximum Specifications

Operating temp.	-40°C to +85°C
Storage temp.	-55°C to +125°C
V _{DD}	0 to +6.5V
Max continuous pin current, any control or drive pin.	±20mA
Short circuit duration to V _{SS} , any pin.	infinite
Short circuit duration to V _{DD} , any pin.	infinite
Voltage forced onto any pin.	-0.6V to (V _{DD} + 0.6) Volts



CAUTION: Stresses beyond those listed under 'Absolute Maximum Specifications' may cause permanent damage to the device. This is a stress rating only and functional operation of the device at these or other conditions beyond those indicated in the operational sections of this specification is not implied. Exposure to absolute maximum specification conditions for extended periods may affect device reliability.

4.2 Recommended Operating Conditions

V _{DD}	+2.0 to 5.5V
Short-term supply ripple+noise.	±5mV
Long-term supply stability.	±100mV
C _s value.	2nF to 50nF
C _x value.	5 to 20pF

4.3 AC Specifications

V_{DD} = 3.0V, C_s = 10nF, C_x = 5pF, T_a = recommended range, unless otherwise noted

Parameter	Description	Min	Typ	Max	Units	Notes
T _{RC}	Recalibration time		250		ms	C _s , C _x dependent
T _{PC}	Charge duration		2		µs	±7.5% spread spectrum variation
T _{PT}	Transfer duration		2		µs	±7.5% spread spectrum variation
T _{G1}	Time between end of burst and start of the next (Fast mode)		1		ms	
T _{G2}	Time between end of burst and start of the next (LP mode)		85		ms	Increases with reducing V _{DD}
T _{BL}	Burst length		20		ms	V _{DD} , C _s and C _x dependent. See Section 3.2 for capacitor selection.
T _R	Response time			100	ms	
T _{HB}	Heartbeat pulse width		15		µs	

4.4 Signal Processing

Description	Min	Typ	Max	Units	Notes
Threshold differential		10		counts	
Hysteresis		2		counts	
Consensus filter length		4		samples	
Max on-duration		80		secs	(At 3V) Will vary in SYNC mode and with V _{DD}

4.5 DC Specifications

$V_{DD} = 3.0V$, $C_s = 10nF$, $C_x = 5pF$, $T_a =$ recommended range, unless otherwise noted

Parameter	Description	Min	Typ	Max	Units	Notes
V_{DD}	Supply voltage	2		5.25	V	
I_{DD}	Supply current	5		600	μA	Depending on supply and run mode
I_{ddl}	Supply current, LP Mode		9 15 35		μA	2V 3V 5V
V_{Dds}	Supply turn-on slope	100			V/s	Required for proper start-up
V_{IL}	Low input logic level			0.8	V	
V_{HL}	High input logic level	2.2			V	
V_{OL}	Low output voltage			0.6	V	OUT, 4mA sink
V_{OH}	High output voltage	$V_{DD}-0.7$			V	OUT, 1mA source
I_{IL}	Input leakage current			± 1	μA	
C_x	Load capacitance range	0		100	pF	
A_R	Acquisition resolution		9	14	bits	

4.6 Mechanical Dimensions

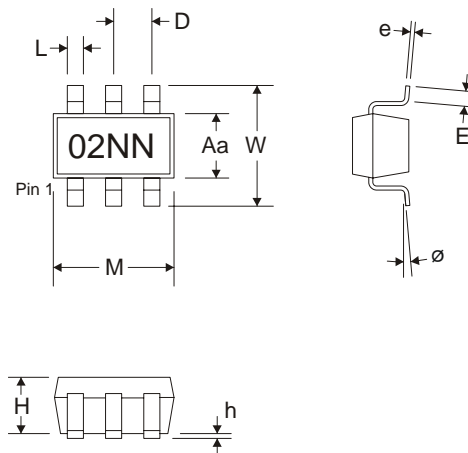

Package type: SOT23-6						
Symbol	Millimeters			Inches		
	Min	Max	Notes	Min	Max	Notes
M	2.8	3.10		0.110	0.122	
W	2.6	3.0		0.102	0.118	
Aa	1.5	1.75		0.059	0.069	
H	0.9	1.3		0.035	0.051	
h	0.0	0.15		0	0.006	
D	-	-	0.95 BSC	-	-	0.038 BSC
L	0.35	0.5		0.014	0.02	
E	0.35	0.55		0.014	0.022	
e	0.09	0.2		0.004	0.008	
Ø	0°	10°		0°	10°	

4.7 Marking

SOT23-6 Part Number	Marking
QT100-ISG	02NN (where NN is variable)

4.8 Moisture Sensitivity Level (MSL)

MSL Rating	Peak Body Temperature	Specifications
MSL1	260°C	IPC/JEDEC J-STD-020C

5 Datasheet Control

5.1 Changes

Changes this datasheet issue (09)

- Front page
- Section 3.2
- Section 4.1, 4.2, 4.3, 4.4
- Section 5.1

5.2 Numbering Convention

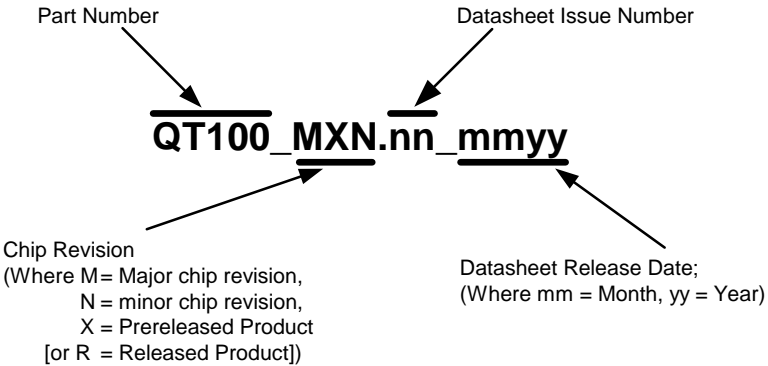

*A minor chip revision (N) is defined as a revision change which does not affect product functionality or datasheet.
The value of N is only stated for released parts (R).*

NOTES:



Copyright © 2006-2007 QRG Ltd. All rights reserved
Patented and patents pending

Corporate Headquarters

1 Mitchell Point
Ensign Way, Hamble SO31 4RF
Great Britain
Tel: +44 (0)23 8056 5600 Fax: +44 (0)23 8045 3939

www.qprox.com

North America

651 Holiday Drive Bldg. 5 / 300
Pittsburgh, PA 15220 USA
Tel: 412-391-7367 Fax: 412-291-1015

The specifications set out in this document are subject to change without notice. All products sold and services supplied by QRG are subject to QRG's Terms and Conditions of sale and services. QRG patents, trademarks and Terms and Conditions can be found online at <http://www.qprox.com/about/legal.php>. Numerous further patents are pending, one or more which may apply to this device or the applications thereof.

QRG products are not suitable for medical (including lifesaving equipment), safety or mission critical applications or other similar purposes. Except as expressly set out in QRG's Terms and Conditions, no licenses to patents or other intellectual property of QRG (express or implied) are granted by QRG in connection with the sale of QRG products or provision of services. QRG will not be liable for customer product design and customers are entirely responsible for their products and applications which incorporate QRG's products.

Developer: Martin Simmons