

Bipolar IC

Features

- Multistandard video IF
- Interference suppression circuitry
- Mean/peak value control
- Area of application: multistandard TV / VCR, mono, stereo cable converter, mono, stereo

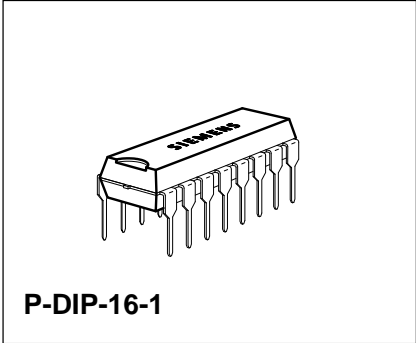

| Type | Ordering Code | Package |
|------------|---------------|------------|
| TDA 5930-5 | Q67000-A5135 | P-DIP-16-1 |

Circuit Description

Video IF for all European standards. The analog setting function (delayed tuner AGC threshold) is controlled via a potentiometer.

The IC is suitable for use in Euro- or multi-standard TV sets for mono and stereo application.

The component includes a four-stage, capacitively coupled, symmetrically designed and controlled amplifier, a limiter with selection, and a mixer for quasi-synchronous demodulation of positive and negative modulated IF signals. In addition a video output amplifier and noise suppression circuitry are included. This output is used for generating the AGC voltage. The AGC for both modulation types has been realized as integral AGC with noise-free peak and mean value detector (only for positive modulation). A delayed tuner AGC with positive AGC direction (increase in tuner AGC voltage → increased gain) is derived from the AGC voltage via a threshold amplifier set by means of an external potentiometer.

A positive video output with 3 Vpp and a negative video output with 2 Vpp are available.

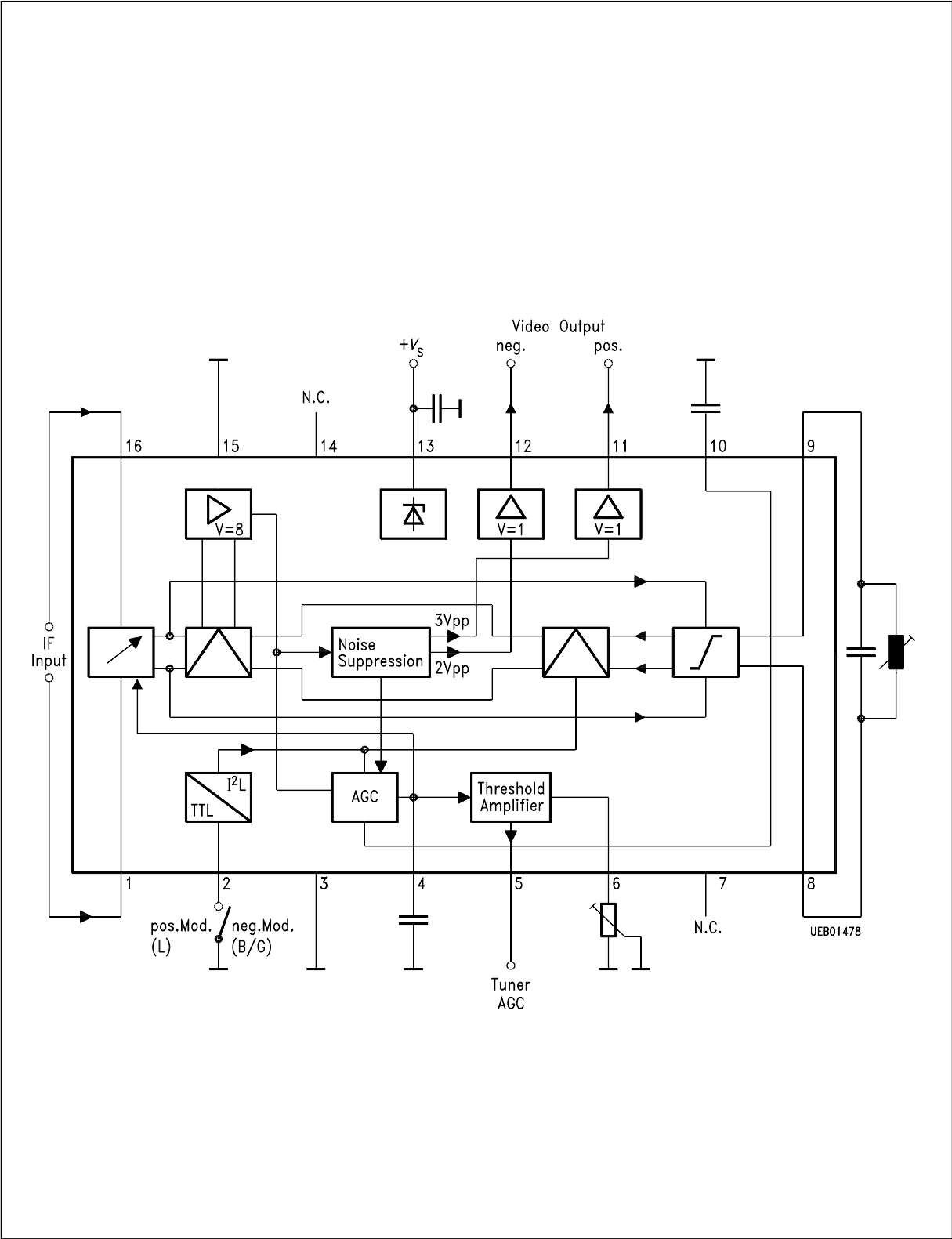

Block Diagram

Pin Functions

| Pin No. | Function |
|----------------|----------------------------------|
| 1 | Video IF input |
| 2 | Standard switch over B/G-L |
| 3 | Ground |
| 4 | AGC time constant |
| 5 | Tuner AGC output |
| 6 | Tuner AGC threshold |
| 7 | N.C. |
| 8 | Demodulator tank circuit |
| 9 | Demodulator tank circuit |
| 10 | Low pass (mean value generation) |
| 11 | Positive video output |
| 12 | Negative video output |
| 13 | Supply voltage |
| 14 | N.C. |
| 15 | Ground |
| 16 | Video IF input |

Absolute Maximum Ratings

$T_A = 25\text{ °C}$

| Parameter | Symbol | Limit Values | | Unit |
|---------------------------------|--------------|--------------|------------|------|
| | | min. | max. | |
| Supply voltage | V_{13} | 0 | 13.5 | V |
| Pos. video output | I_{11} | - 3 | 5 | mA |
| Pos. video output | V_{11} | 0 | 10 | V |
| Demodulator tank circuit | V_8/V_9 | 0 | + V_{13} | V |
| Neg. video output | I_{12} | - 3 | 5 | mA |
| Neg. video output | V_{12} | 0 | + V_{13} | V |
| Tuner AGC threshold | V_6 | 0 | 6 | V |
| Tuner AGC output | V_5 | 0 | + V_{13} | V |
| IF input | V_1/V_{16} | 0 | 6 | V |
| IF control | V_4 | 0 | 8.5 | V |
| Standard switch-over | V_2 | 0 | 6 | V |
| Auxiliary control | V_{10} | 0 | 6 | V |
| Junction temperature | T_j | | 150 | °C |
| Storage temperature | T_{stg} | - 40 | 125 | °C |
| Thermal resistance (system-air) | $R_{th SA}$ | | 70 | K/W |

Operating Range

| | | | | |
|--------------------------------------|----------|------|------|-----|
| Supply voltage | V_{13} | 10.5 | 13.5 | V |
| Supply voltage, delayed tuner AGC | V_5 | 1 | 13.5 | V |
| Ambient temperature during operation | T_A | 0 | 70 | °C |
| Input frequency range - 3 dB | f_{IF} | 10 | 100 | MHz |
| Input frequency range - 0.3 dB | f_{IF} | 30 | 75 | MHz |

All voltage values are referenced to ground pin 3, 15, if not stated otherwise. The currents are identified according to the source/sink principle.

If the IC is considered a sink (the current flows from the respective pin to ground), it is identified by a negative algebraic sign.

However, if the IC is the source (the current flows from V_8 via the respective pin), it is identified by a positive algebraic sign.

Characteristics

$V_S = V_{13/15} = 12\text{ V} \pm 10\%$; $T_A = 25\text{ }^\circ\text{C}$

| Parameter | Symbol | Limit Values | | | Unit | Test Condition |
|-----------|--------|--------------|------|------|------|----------------|
| | | min. | typ. | max. | | |

DC Characteristics

| | | | | | | |
|--------------------------|--|----|----|----|----|------------------------------|
| Tot. current consumption | | 37 | 53 | 69 | mA | $V_{1/16} = 10\text{ mVrms}$ |
|--------------------------|--|----|----|----|----|------------------------------|

AGC Voltage (figure 1)

| | | | | | | |
|----------|-------|-----|------|-----|---|---------------------------------------|
| Min. AGC | V_4 | 0 | 0.1 | 0.5 | V | $V_{1/16} = 45\text{ }\mu\text{Vrms}$ |
| Max. AGC | V_4 | 2.6 | 2.85 | 4.5 | V | $V_{1/16} = 175\text{ mVrms}$ |

AGC-Time Constant (figure 6) with Neg. Modulation

| | | | | | | |
|---------------------------------------|--------|-----|-----|-----|---------------|---|
| Charge current ($I_{\text{max}:2}$) | I_4 | 0.7 | 0.9 | 1.1 | mA | $V_4 = 2\text{ V}; V_{11} < 5.2\text{ V}$ |
| Discharge current | $-I_4$ | 12 | 17 | 23 | μA | $V_4 = 2\text{ V}; V_{11} > 6.3\text{ V}$ |
| Charge/discharge ratio | V_4 | 75 | 105 | 150 | | |

AGC-Time Constant (figure 7) with Pos. Modulation

| | | | | | | |
|------------------------|--------|-------|-------|-------|---------------|---|
| Charge current | I_4 | 5.5 | 7 | 8.0 | mA | $V_4 = 2\text{ V}; V_{11} \geq 9\text{ V}$ |
| Discharge current | $-I_4$ | 0.1 | 0.2 | 0.3 | μA | $V_4 = 2\text{ V};$ $4.5\text{ V} < V_{11} < 8.2\text{ V}$ |
| Discharge current | $-I_4$ | 270 | 330 | 420 | μA | $V_4 = 2\text{ V}; V_{11} < 6\text{ V}$ |
| Charge/discharge ratio | V_4 | 20000 | 35000 | 75000 | | |

Mean Value Generation with Pos. Modulation

| | | | | | | |
|------------------------------------|----------|------|-----|------|---------------|---|
| White level | V_{10} | 3.9 | 4.3 | 4.7 | V | $V_{1/16} = 10\text{ mVrms}$ |
| Zero carrier level | V_{10} | 3.3 | 3.7 | 4.1 | V | $V_{1/16} = 0\text{ V}; V_4 = 3\text{ V}$ |
| Tuner AGC threshold (figure 2) | V_6 | 3.9 | 4.3 | 4.7 | V | $R_{6/15} = \infty$ |
| $I_5 = I_{\text{max}:2}$ | I_6 | 550 | 750 | 950 | μA | $V_6 = 0\text{ V}$ |
| | V_4 | 2.8 | 3.1 | 3.4 | V | $R_{6/15} = 10\text{ k}\Omega$ |
| | V_4 | 0.35 | 0.4 | 0.45 | V | |
| Tuner AGC current (figure 3, 4) | $-I_5$ | 3.0 | 4.0 | 5.0 | mA | $V_5 = 0.5\text{ }V_{13}$ $V_{1/16} = 100\text{ mVrms}$ $V_6 = 0.75\text{ V}$ |
| | $-I_5$ | 0 | – | 10 | μA | $V_5 = 0.5\text{ }V_{13}$ $V_{1/16} = 10\text{ mVrms}$ $V_6 = 4.0\text{ V}$ |

The characteristics data apply to the supply voltage range V_S stated or in case of alignment to the alignment instructions (see page 21). All static voltages are referenced to ground if not stated otherwise.

The input levels are given as rms values referenced to synchronous peak $f_{PC} = 38.9\text{ MHz}$.

Characteristics (cont'd)

$T_A = 25\text{ °C}$

| Parameter | Symbol | Limit Values | | | Unit | Test Condition |
|-----------|--------|--------------|------|------|------|----------------|
| | | min. | typ. | max. | | |

Mean Value Generation with Pos. Modulation (cont'd)

| | | | | | | |
|--------------------------|---------------|-------------------|-------------------|-------------------|---|--|
| IF input | V_1, V_{16} | 5.7 | 6.0 | 6.3 | V | |
| Demodulator tank circuit | V_8, V_9 | V_{13} - 3.5 | V_{13} - 3.8 | V_{13} - 4.1 | V | |

Pos. Video Output (figure 8)

| | | | | | | |
|----------------|-----------|-----|-----|-----|----|---|
| Output current | $-I_{11}$ | 1.7 | 2.2 | 2.7 | mA | $V_{11} = 9\text{ V}$ to ground via $R = 1\text{ k}\Omega$ |
| | I_{11} | 4 | | | mA | |

Pos. Modulation (L norm)

| | | | | | | |
|----------------------|----------|-----|-----|-----|---|---|
| White level | V_{11} | 5.9 | 6.6 | 7.3 | V | $V_{1/16} = 10\text{ mVrms}$ |
| Zero carrier (sync.) | V_{11} | 3.3 | 3.6 | 4.0 | V | $V_{1/16} = 0\text{ V}; V_4 = 3\text{ V}$ |

Neg. Modulation (BG norm)

| | | | | | | |
|-------------------|----------|-----|-----|-----|---|---|
| Sync. pulse level | V_{11} | 3.3 | 3.6 | 4.0 | V | $V_{1/16} = 10\text{ mVrms}$ |
| Zero carrier | V_{11} | 6.2 | 6.9 | 7.6 | V | $V_{1/16} = 0\text{ V}; V_4 = 3\text{ V}$ |

Neg. Video Output (figure 9)

| | | | | | | |
|----------------|-----------|-----|-----|-----|----|-------------------------------------|
| Output current | $-I_{12}$ | 1.7 | 2.2 | 2.7 | mA | $R_L = \infty$ $V_{12} = V_{13}$ |
| | I_{12} | 4 | | | mA | |

Pos. Modulation (L norm)

| | | | | | | |
|----------------------|----------|-------------------|--------------------|-------------------|---|---|
| White level | V_{12} | V_{13} - 5.7 | V_{13} - 4.95 | V_{13} - 4.2 | V | $V_{1/16} = 10\text{ mVrms}$ |
| Zero carrier (sync.) | V_{12} | V_{13} - 3.3 | V_{13} - 2.8 | V_{13} - 2.4 | V | $V_{1/16} = 0\text{ V}; V_4 = 3\text{ V}$ |

Neg. Modulation (BG norm)

| | | | | | | |
|-------------------|----------|-------------------|-------------------|-------------------|---|---|
| Sync. pulse level | V_{12} | V_{13} - 3.3 | V_{13} - 2.8 | V_{13} - 2.4 | V | $V_{1/16} = 10\text{ mVrms}$ |
| Zero carrier | V_{12} | V_{13} - 5.9 | V_{13} - 5.2 | V_{13} - 4.4 | V | $V_{1/16} = 0\text{ V}; V_4 = 3\text{ V}$ |

Video output voltages (peak-to-peak) $PC = 10\text{ mVrms}$

with neg. modulation = 10 %; with pos. modulation and residual carrier < 6 %.

Characteristics (cont'd)

$T_A = 25\text{ °C}$

| Parameter | Symbol | Limit Values | | | Unit | Test Condition |
|-----------|--------|--------------|------|------|------|----------------|
| | | min. | typ. | max. | | |

Switching Voltage (figure 12)

| | | | | | | |
|------------------------|-------|-----|--|-----|---|--|
| L = L/E standard | V_2 | 0 | | 1.8 | V | |
| H = B/G stand. or open | V_2 | 2.6 | | 6 | V | |

Dynamic Characteristics

Min. IF-Input Voltage (figure 1)

| | | | | | | |
|------------------------------------|--|--|----|----|---------|--------------------------|
| (min. gain) $PC\ rms\ V_{1/16}$ | | | 45 | 60 | μV | $V_{11pp} - 1\text{ dB}$ |
|------------------------------------|--|--|----|----|---------|--------------------------|

Max. IF-Input Voltage (figure 1)

| | | | | | | |
|---|-------------------------------------|------|------|------|----------|--|
| (max. gain) $PC\ rms$ | | 105 | 140 | | mV | $V_{1/16}\ V_{11pp} + 1\text{ dB}$ |
| IF-control range (figure 1) | ΔV | 65 | 70 | | dB | |
| Pos. video output (figure 8) | V_{11} | 2.7 | 3.0 | 3.3 | V_{pp} | $R_L \geq 1.5\text{ k}\Omega$ |
| Change ΔV_{11} by standard switch-over | ΔV_{11} | | 1 | 5 | % | 0 V < V_2 < 2 V = B/G Operat. 2.6 V < V_2 < 6 V = L Operat. |
| Changes via operating voltage | $\Delta V_{11}/$ ΔV_{13} | | 1.5 | 3 | % | 10.8 V < V_{13} < 13.2 V |
| Neg. video output (figure 9) | V_{12} | 1.95 | 2.15 | 2.35 | V_{pp} | $R_L = \infty$ |
| Video output voltage change (figure 8) by means of a control range of 55 dB | | | | | | |
| | ΔV_{11} | | 0.2 | 0.5 | dB | |

Design Notes (no 100 % final test)

| | | | | | | |
|--|------------------------|-----|-----|-----|-----------|------------------------------------|
| Input resistance (symmetrical) | $R_{1/16}$ | 1.5 | 2 | 2.5 | $k\Omega$ | |
| Input capacitance (symmetrical) | $C_{1/16}$ | | 2 | 5 | pF | |
| Low pass cut-off frequency (figure 5) | $f_{-3\text{ dB}(10)}$ | 70 | 100 | 130 | Hz | $C_{10/15} =$ 100 nF $\pm 10\%$ |

Characteristics (cont'd)

$T_A = 25\text{ °C}$

| Parameter | Symbol | Limit Values | | | Unit | Test Condition |
|-----------|--------|--------------|------|------|------|----------------|
| | | min. | typ. | max. | | |

Design Notes (no 100 % final test) (cont'd)

Intercarrier noise voltage ratio (weighted according CCIR 468) (**figure 13**) with parallel tank circuit; 38.9 MHz, SAW 361 D, $f_{SC} = 5.5\text{ MHz}$ (– 13 dB), demodulator: TBA 120 U

| | | | | | | |
|--|---------------|-----|-----|-----|----------|---|
| | S/N | | 48 | | dB | $V_{1/16} = 10\text{ mVpp}$ FuBK mod. |
| | S/N | | 17 | | dB | $V_{1/16} = 10\text{ mVpp}$ 2.753 MHz mod. |
| FuBK-test chart | $-\Delta S/N$ | | 2 | | dB | with detuning $\Delta f = -400\text{ kHz}$ |
| FuBK-test chart | $-\Delta S/N$ | | 11 | | dB | with detuning $\Delta f = +400\text{ kHz}$ |
| Dyn. output resistance pos. video output | R_{11} | 80 | 115 | 150 | Ω | |
| neg. video output | R_{12} | 100 | 150 | 200 | Ω | |
| Noise figure (figure 14) $V_{1/16} = -45\text{ dBm} = +62\text{ dB}\mu\text{V}$ $R_{GEN} = 800\ \Omega$ | F | | 5 | 7 | dB | |

Video noise voltage ratio (**figure 15**) with $PC = 10\text{ mVrms}$

| | | | | | | |
|--|---------------------|----|-----|-----|-----|--|
| 0 dB = 700 mVpp BA unweighted | S/N | 50 | 55 | | dB | |
| weighted according to CCIR Rec. 567-1 | S/N | 55 | 60 | | dB | |
| Video frequency response (figure 16) | | | | | | |
| – 3 dB | $B_{-3\text{ dB}}$ | 8 | 10 | 13 | MHz | |
| – 12 dB | $B_{-12\text{ dB}}$ | 15 | 17 | 20 | MHz | |
| Residual carrier voltage at video output $PC = 10\text{ mVrms}$ Fundamental wave | | | | | | |
| $f = 38.9\text{ MHz}$ | V_{11} | | 3.0 | 6.0 | mV | |
| 1. harmonic wave $f = 77.8\text{ MHz}$ | V_{11} | | 0.3 | 0.6 | mV | |

Characteristics (cont'd)

$T_A = 25\text{ °C}$

| Parameter | Symbol | Limit Values | | | Unit | Test Condition |
|-----------|--------|--------------|------|------|------|----------------|
| | | min. | typ. | max. | | |

Design Notes (no 100 % final test) (cont'd)

| | | | | | | |
|---|--|----------------|----------------|-----|-------------------|------------------------------------|
| Differential gain CCIR Rec. 567-1 (figure 17) with $PC = 10\text{ mV}$ peak-to-peak according to stairsignal test Changes via AGC Changes via detuning $f_{BT} = 38.9\text{ MHz}$; $\Delta f = \pm 400\text{ kHz}$ | DG $\Delta DG/\Delta v$ $\Delta DG/\Delta f$ | | 4 | 6 | % % % | |
| Differential phase CCIR Rec. 567-1 (figure 17) with $PC = 10\text{ mVrms}$ peak-to-peak according to stairsignal test Changes via AGC Changes via detuning $f_{BT} = 38.9\text{ MHz}$; $\Delta f = \pm 400\text{ kHz}$ | DP $\Delta DP/\Delta v$ $\Delta DP/\Delta f$ | | 1.5 | 2.5 | deg deg deg | |
| Intermodulation ratio (figure 18) with $f_{IM} = 1.07\text{ MHz} = f_{SC} - f_{CC}$ with $PC = 10\text{ mVrms}$ with sound porch – 3 dB with sound porch – 20 dB with sound porch – 17 dB | a_{IM} a_{IM} a_{IM} | 32 54 51 | 38 60 57 | | dB dB dB | OFWG 3950 OFW 3610 OFWG 1956 |
| Demodulator tank circuit voltage $f_{PC} = 38.9\text{ MHz}$; $C = 47\text{ pF}$ $L = 350\text{ nH}$ $100 \leq Q_0 \leq 120$; $Q_B \approx 60$; $B \approx 0.8 \dots 1.0\text{ MHz}$ | $V_{8/9}$ | 300 | 450 | 600 | mVpp | |
| Synchronous pulse | $\Delta V_{Sync}/V_{11}$ | | | 5 | % | |

Characteristics (cont'd)

$T_A = 25\text{ °C}$

| Parameter | Symbol | Limit Values | | | Unit | Test Condition |
|-----------|--------|--------------|------|------|------|----------------|
| | | min. | typ. | max. | | |

Design Notes (no 100 % final test) (cont'd)

| | | | | | | |
|--|--|--|--|----|---------------|---|
| Temperature drift of the tuner AGC threshold referred to the input voltage | | | | 2 | dB | $I_5 = I_{5max}/2$ caused by the self-heating of the ICs 10 s to 15 min. |
| Ratio pulse bar tilt to sync. amplitude | | | | 4 | % | |
| Reaction time of white level peak setting, L standard | | | | 10 | μs | low-pass filter in regulation slope ca. 300 kHz |

Alignment Instructions

At a video carrier input level of $V_{1/16} = 4\text{ mVrms}$, $f_{PC} = 38.9\text{ MHz}$, and a superimposed AGC voltage of $V_4 = 1.5\text{ V}$, the demodulator tank circuit is preliminarily aligned until a max. video signal V_{11pp} is obtained at the positive video output. Any suitable video test signal can be used for modulation. The AGC voltage V_4 is reduced until the signal is approx. 3 Vpp and the max. video signal is obtained when fine-aligning the demodulator tank circuit. The alignment is not critical due to relatively large bandwidth of the demodulator tank circuit. Fine-tuning to intercarrier S/N , differential phase or 2T-pulse characteristics is possible.

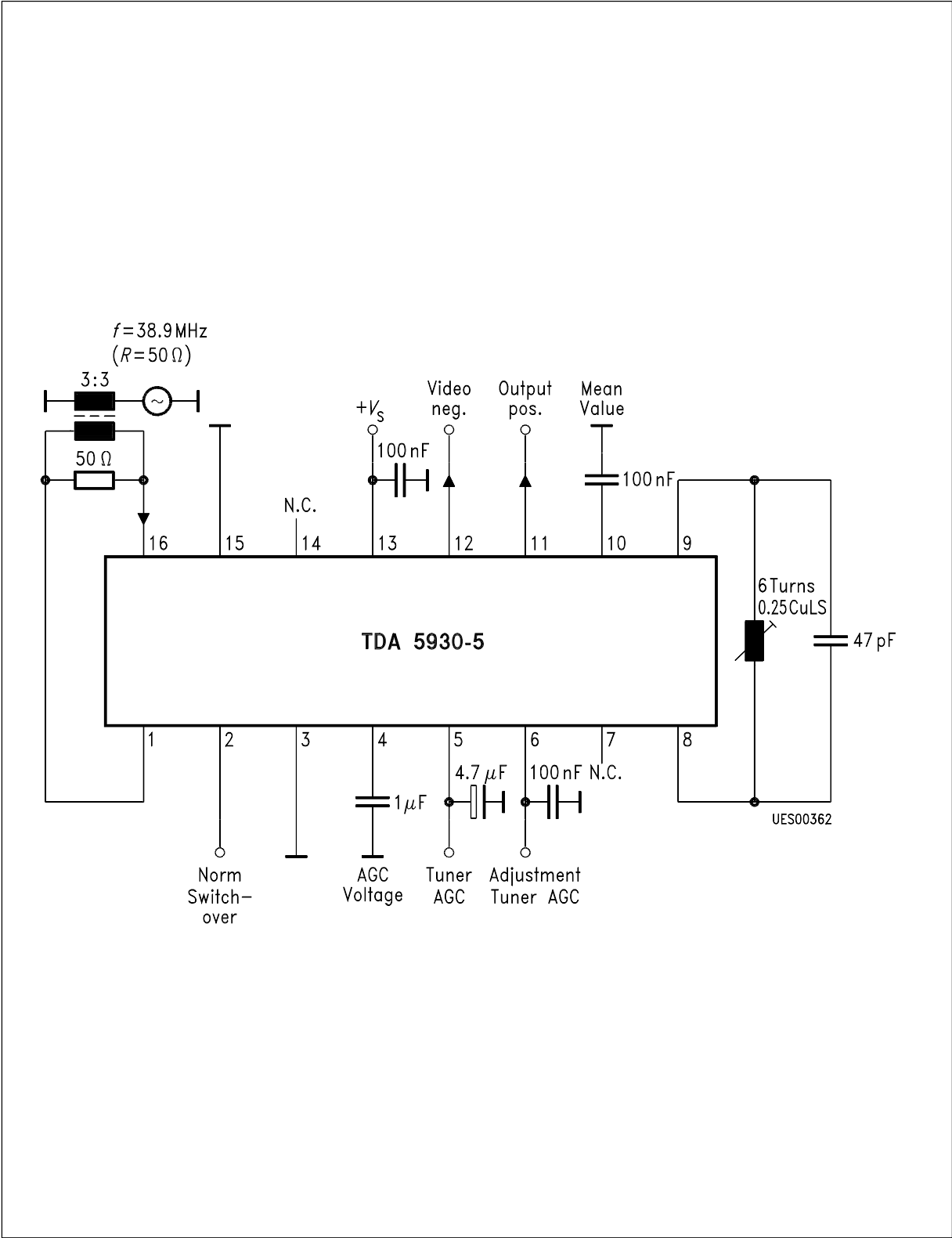

Test Circuit

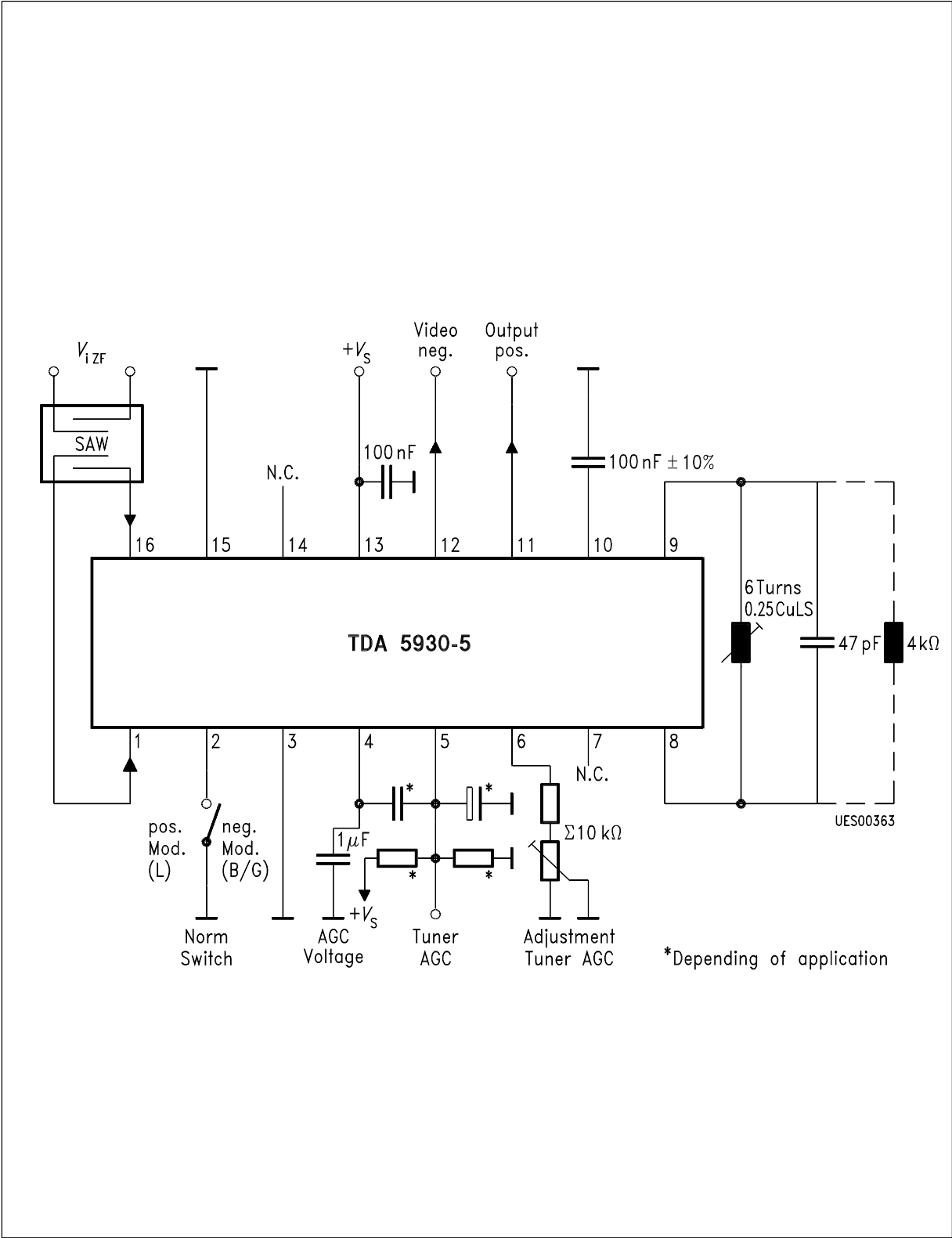

Application Circuit

AGC Voltage

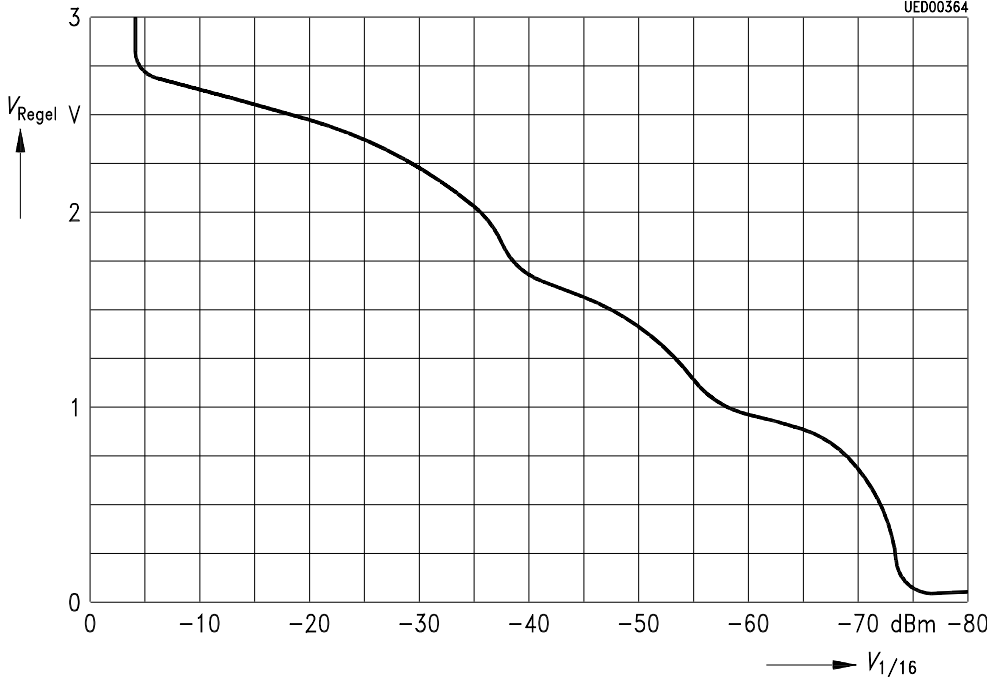

Inset Point AGC Voltage

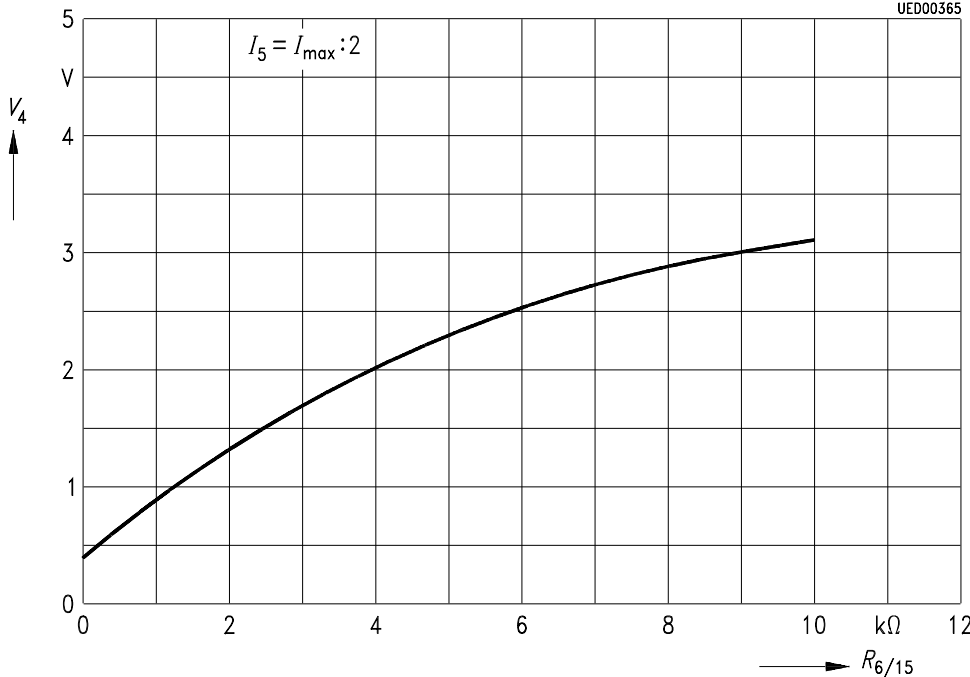

Tuner AGC Current

$I_5 = f(V_4)$

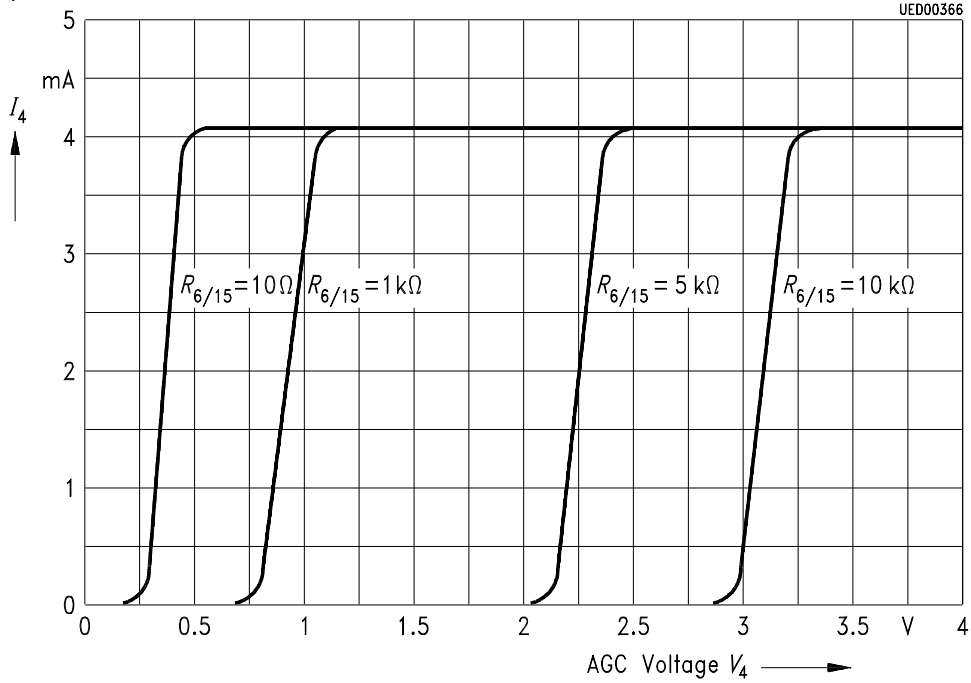

Low-Pass Cut-Off Frequency (pin 10)

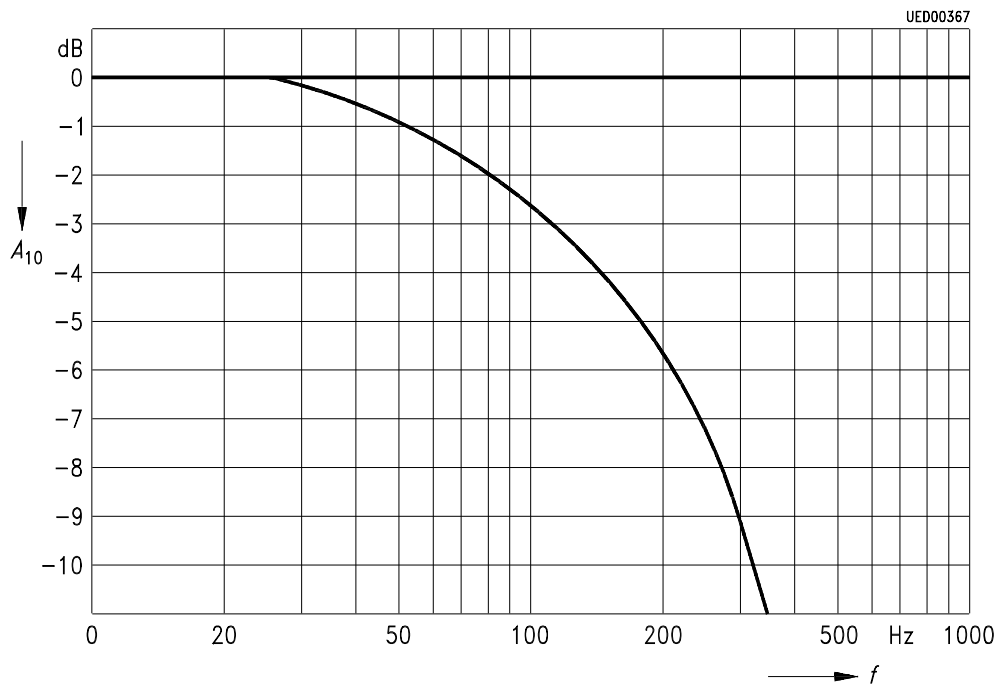

Measurement condition: ext. modulation: 10 Hz – 1 kHz sine 30 % AM
 video generator: ext. negative setup on half sync level, field off

AGC Time Constant Neg. Modulation

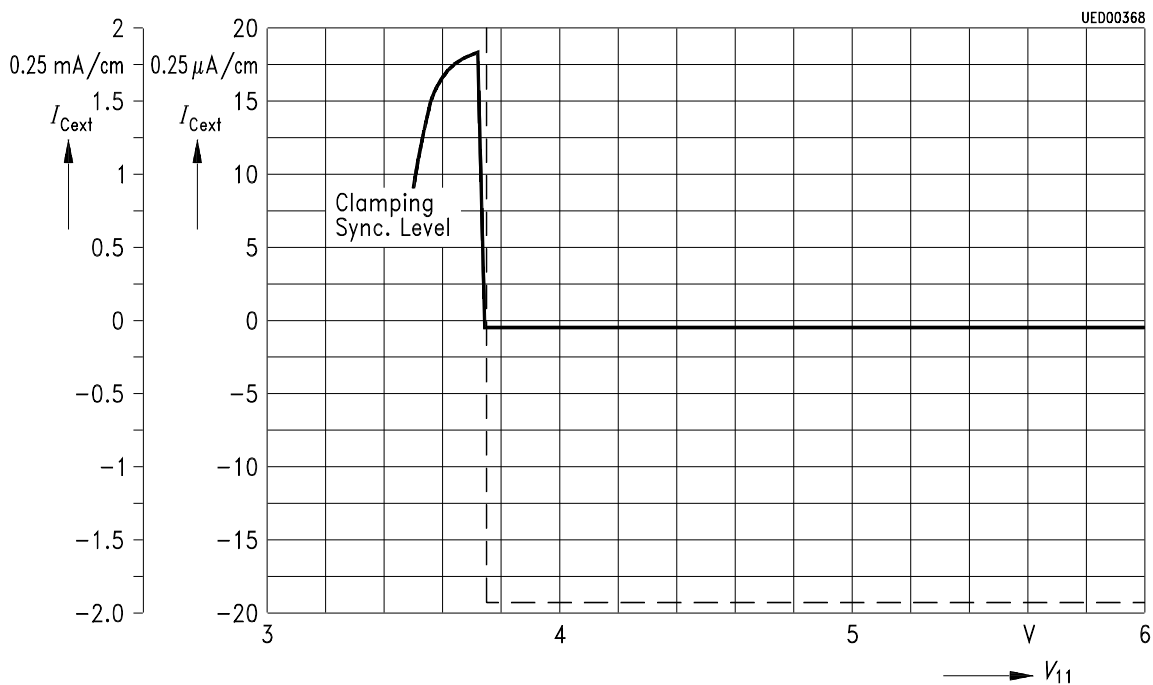

AGC Time Constant Pos. Modulation

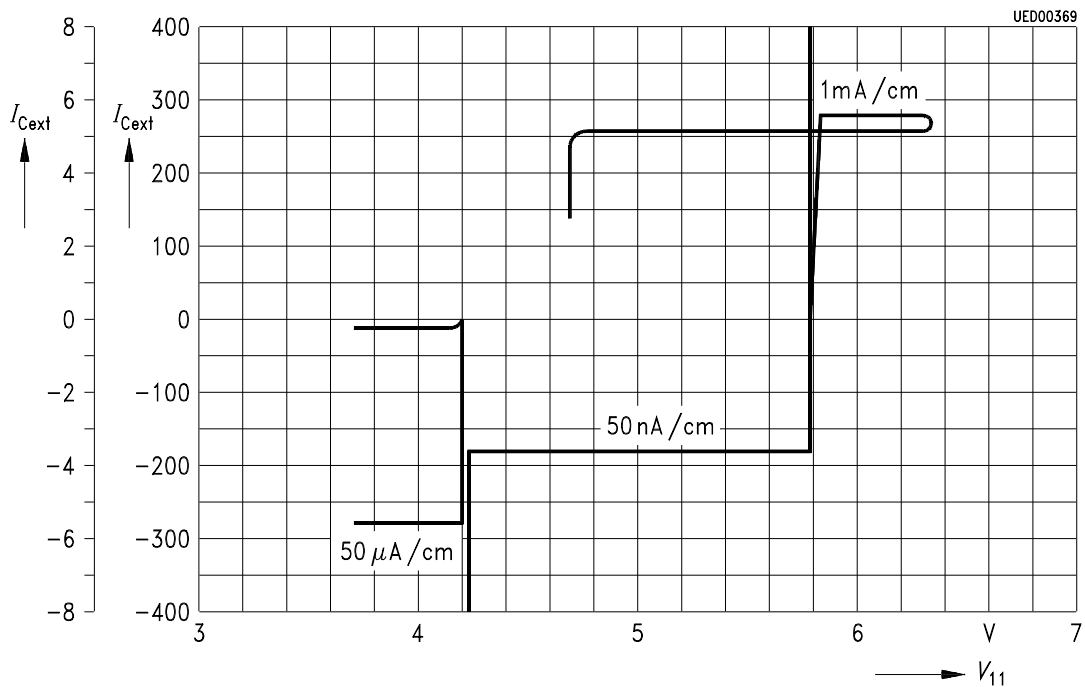

Pos. Video Output (pin 11)

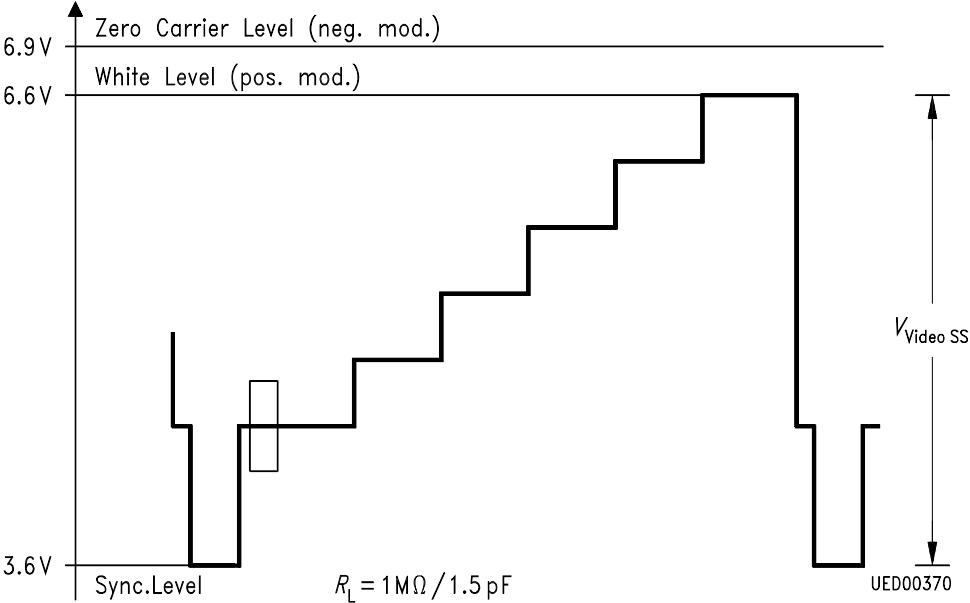

Neg. Video Output (pin 12)

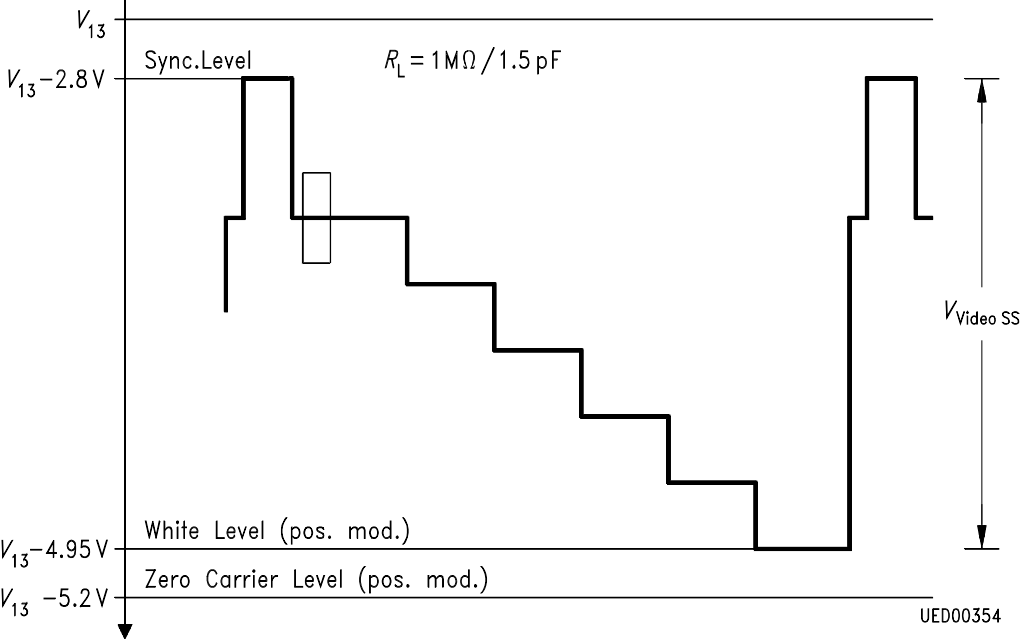

Voltage Dependent Load at Video Output

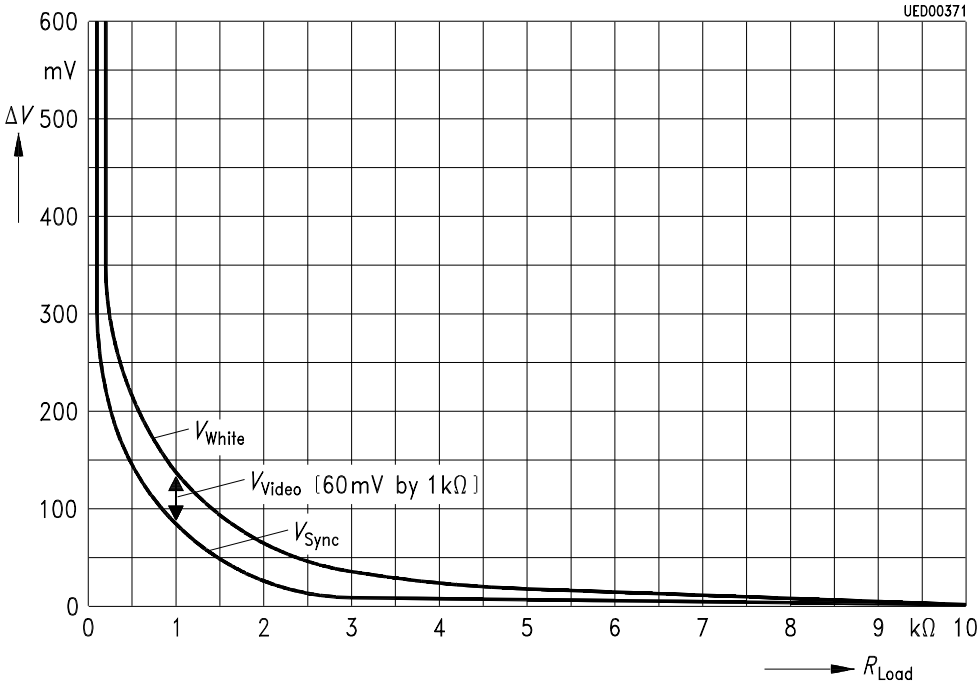

Switching Voltage

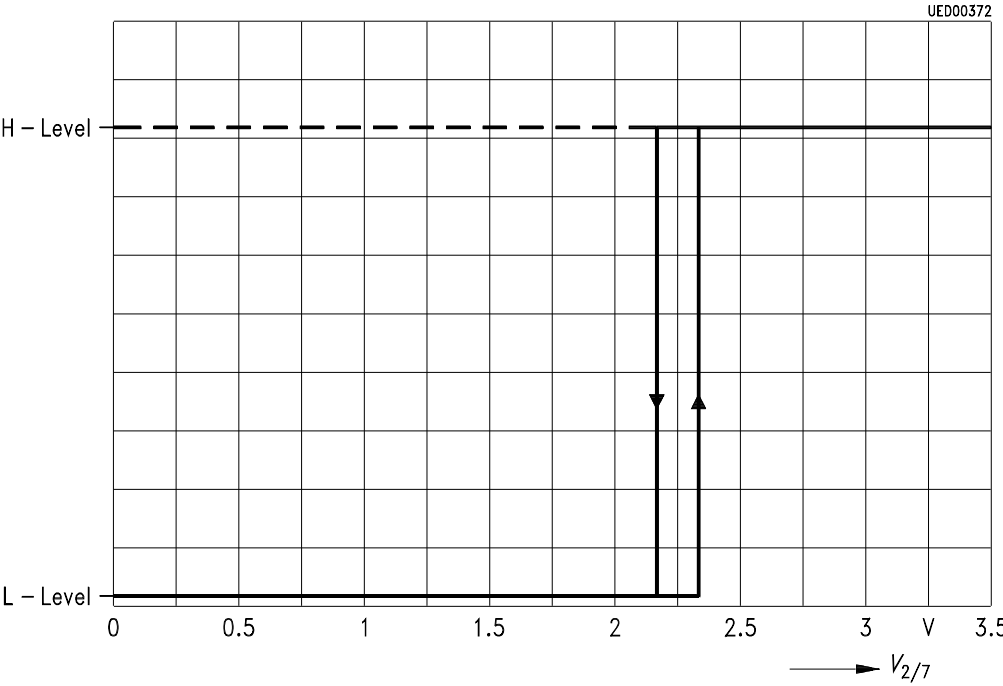

Inter-carrier Interference Voltage
(weighted according to CCIR 468)

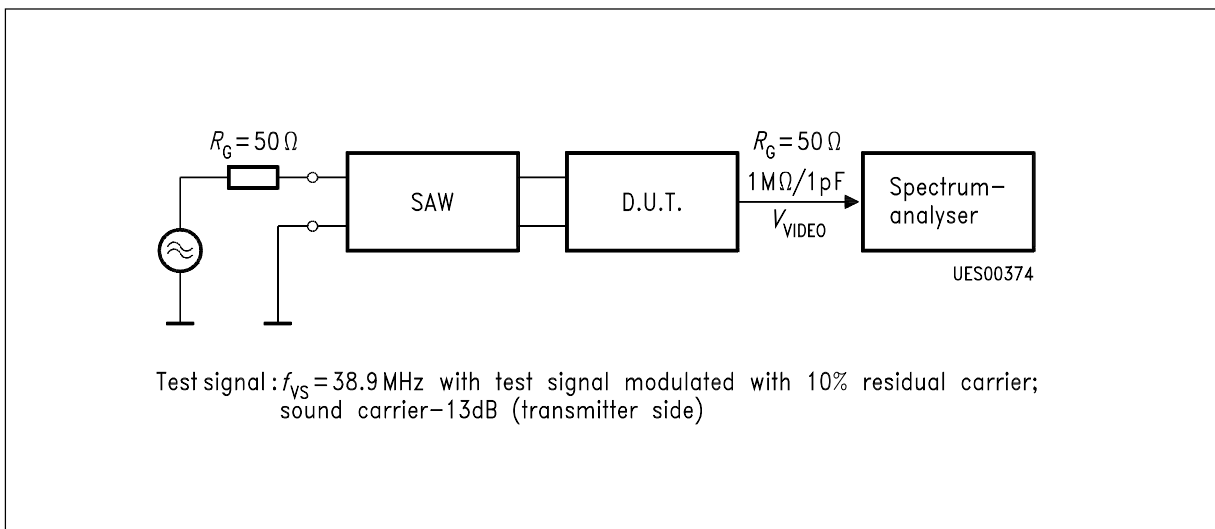
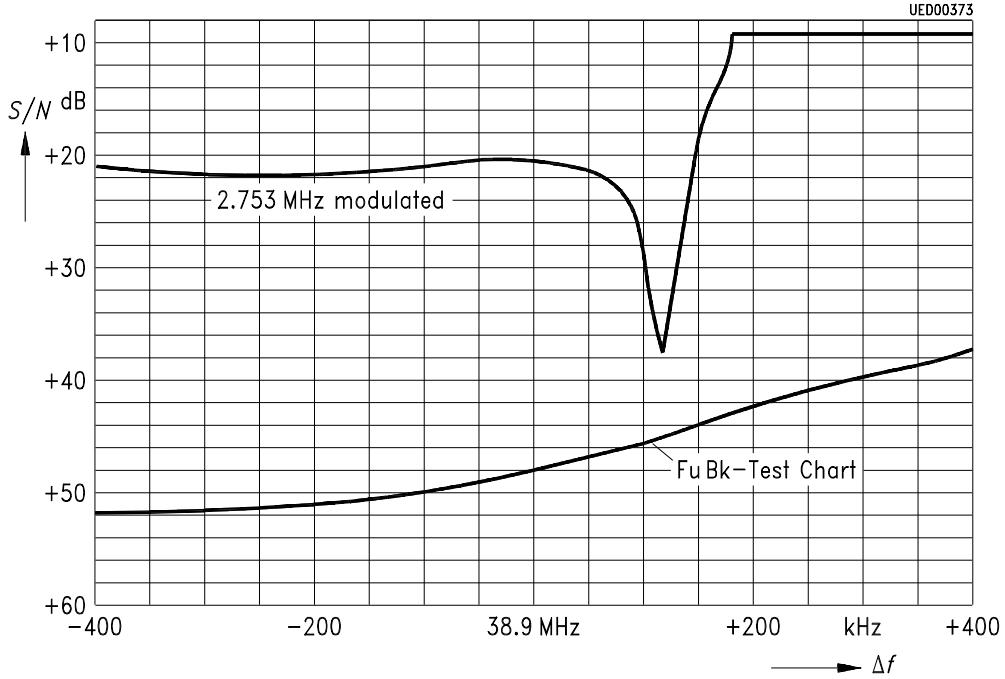

Measurement Configuration