

MF1051S-1

FOR DIGITAL MOBILE TELEPHONE, Tx

MF1051S-1

DESCRIPTION

This SAW filter for the transmitting RF circuit of digital mobile communication equipment operating at 1429 MHz ~ 1453 MHz.

FEATURES

1. SMD package insures small size, lightweight.
2. Adjustment free.
3. Low insertion loss and high stop band attenuation.
4. Wide and sharp passband characteristics.
5. High stability and reliability.
6. Designed for reflow solderings.

APPLICATION

- Digital mobile cellular telephone
- Portable digital cellular telephone
- Wireless equipment

MAXIMUM RATINGS

Rating	Value	Unit
Input Power	40	mW
Operating Temperature Range	-20 to 75	°C
Storage Temperature Range	-30 to 85	°C

ELECTRICAL PERFORMANCE

Parameter	MF1051S-1			Units
	Min	Typ	Max	
PASSBAND FREQUENCY	1429 ~ 1453			MHz
PASSBAND CHARACTERISTICS	Insertion Loss	2.2	2.8	dB
	Ripple	0.6	1.5	dBp-p
	VSWR	1.8	2.5	
STOPBAND ATTENUATION	0 ~ 1050 MHz	30	35	dB
	1050 ~ 1360 MHz	20	23	dB
	1477 ~ 1501 MHz	6	7.5	dB
	1607 ~ 1631 MHz	30	35	dB
	1785 ~ 1809 MHz	27	32	dB
1809 ~ 3000 MHz	20	23	dB	

PACKAGE OUTLINE DIMENSIONS

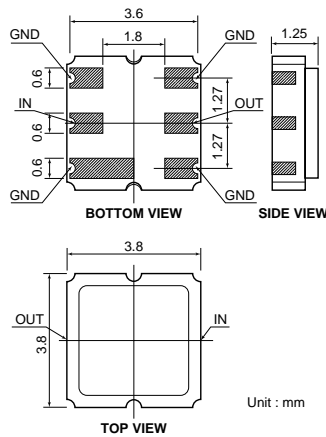

DIMENSIONS ARE IN MILLIMETERS
±0.2 UNLESS OTHERWISE SPECIFIED

MF1051S-1 TYPICAL CHARACTERISTICS

