

LH0002 Buffer



LH0002

FEATURES

- High Input Impedance..... 400k Ω
- Low Output Impedance..... 3 Ω
- High Power Efficiency
- Low Harmonic Distortion
- Bandwidth DC to 50MHz
- Output Voltage Swing that Approaches Supply Voltage
- Pulsed Output Current 400mA
- Slew Rate 200V/ μ s
- Operation \pm 5V to \pm 20V

APPLICATIONS

- Line Driver
- Instrumentation Shield Driver
- High Speed D/A Conversion
- Precision Current Source
- Video Driver

GENERAL DESCRIPTION

The LH0002 is a high speed unity gain buffer designed to provide high current drive capability at frequencies from DC to over 50MHz. It is capable of providing a continuous current of \pm 100mA and a peak of \pm 400mA. It is ideal to integrate with an operational amplifier inside a close loop configuration.

ORDERING INFORMATION

Part	Package	Temperature Range
LH0002H	HO8 (TO5-8 Lead)	-55 $^{\circ}$ C to +125 $^{\circ}$ C
LH0002CH	HO8 (TO5-8 Lead)	-40 $^{\circ}$ C to +85 $^{\circ}$ C
LH0002CN	N10A (Plastic DIP-10 Pin)	-40 $^{\circ}$ C to +85 $^{\circ}$ C

CONNECTION DIAGRAMS

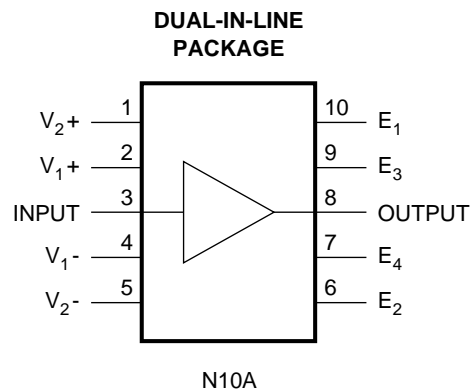
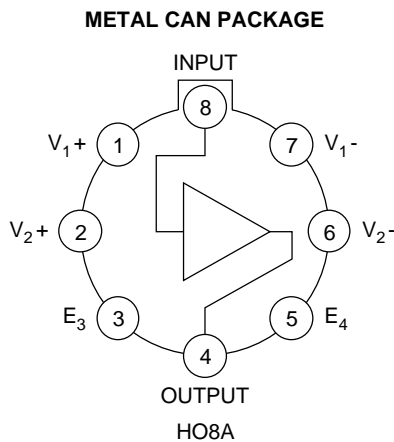

ABSOLUTE MAXIMUM RATINGS (Note 2)

If Military/Aerospace specified devices are required, please contact the Calogic Sales Office for availability and specifications.

Supply Voltage	±22V
Power Dissipation (Note 3)	600mW
Input Voltage	(Equal to Power Supply Voltage)
Storage Temperature Range	-65°C to +150°C
Junction Temperature	
N Package	+150°C
H Package	+175°C
Steady State Output Current	±100mA
Pulsed Output Current (50ms On/1 sec. Off)	±400mA
Lead Temperature Soldering (10 seconds)	
Metal Can	300°C
Plastic	300°C
ESD Rating (Note 5)	2kV

OPERATING RATINGS (Note 3)

Temperature Range	
LH0002H	-55°C to +125°C
LH0002C	-40°C to +85°C

Thermal Resistance (Note 4)

θ_{JA} , H Package	125°C/W
θ_{JC} , H Package	15°C/W
θ_{JA} , N Package	120°C/W

ELECTRICAL CHARACTERISTICS (Note 1)

SYMBOL	PARAMETER	MIN	TYP	MAX	UNITS	CONDITIONS
A_V	Voltage Gain	0.95	0.97			$R_S = 10k\Omega$, $R_L = 1.0k\Omega$, $V_{IN} = \pm 10V$
R_{IN}	Input Impedance	180	400		k Ω	$R_S = 200k\Omega$, $V_{IN} = \pm 1.0V$, $R_L = 1.0k\Omega$,
R_O	Output Impedance		6.0	10	Ω	$V_{IN} = \pm 1.0V$, $R_L = 50\Omega$, $R_S = 10k\Omega$
V_{O1}	Output Voltage Swing	±10	±11		V	$R_L = 1.0k\Omega$, $V_{IN} = \pm 12V$
V_{O2}	Output Voltage Swing	±10	±11		V	$V_S = \pm 15V$, $V_{IN} = \pm 12V$, $R_S = 50\Omega$, $R_L = 100\Omega$, $T_A = 25^\circ C$
V_{OS}	DC Output Offset Voltage		±10	±30	mV	$R_S = 300\Omega$, $R_L = 1.0k\Omega$,
I_B	DC Input Bias Current		±6.0	±10	μA	$R_S = 10k\Omega$, $R_L = 1.0k\Omega$,
HDT	Harmonic Distortion		0.1		%	$V_{IN} = 5.0V_{rms}$, $f = 1.0kHz$
R/T	Rise Time		7.0	12	ns	$R_L = 50\Omega$, $\Delta V_{IN} = 100mV$
I_{S+}	Positive Supply Current		+6.0	+10	mA	$R_S = 10k\Omega$, $R_L = 1.0k\Omega$,
I_{S-}	Negative Supply Current		-6.0	-10	mA	$R_S = 10k\Omega$, $R_L = 1.0k\Omega$,

Note 1. Specification applies for $T_A = 25^\circ C$ with +12V on Pins 1 and 2; -12V on Pins 6 and 7 for the metal can package and +12V on Pins 1 and 2; -12V on Pins 4 and 5 for the dual-in-line package, unless otherwise specified. The parameter guarantees for LH0002C apply over the temperature range of 0°C to +85°C while parameters for the LH0002 are guaranteed over the temperature range -55°C to +125°C unless otherwise specified.

Note 2. Absolute Maximum Ratings indicate limits beyond which damage to the device may occur. Operating Ratings indicate conditions for which the devices intended to be functional, but do not guarantee specific performance limits. For guaranteed specifications and test conditions, see the Electrical Characteristics. The guaranteed specifications apply only for the test conditions listed.

Note 3. The maximum power dissipation is a function of maximum junction temperature (T_{JMax}), total thermal resistance (θ_{JA}), and ambient temperature (T_A) maximum allowed power dissipation at any ambient is $P_D = (T_{JMax} - T_A)/\theta_{JA}$.

Note 4. For operating at elevated temperatures, the device must be derated based on the thermal resistance θ_{JA} and T_{JMax} . $T_J = T_A + P_D\theta_{JA}$.

Note 5. Human body model, 1.5k Ω in series with 100pF.

TYPICAL PERFORMANCE CHARACTERISTICS

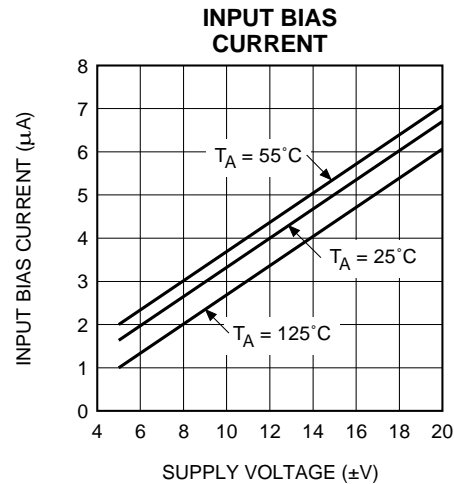
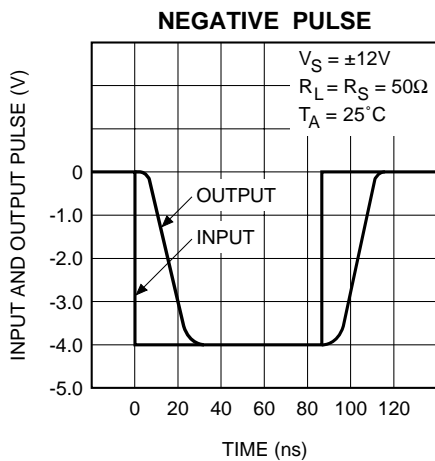
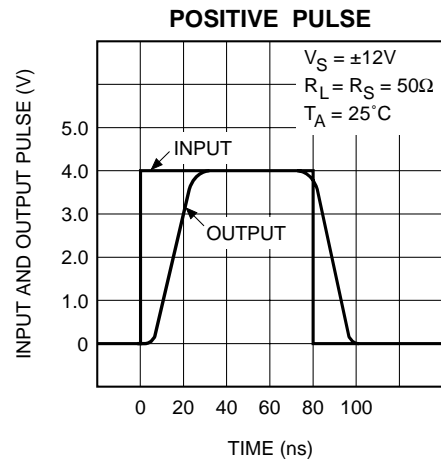
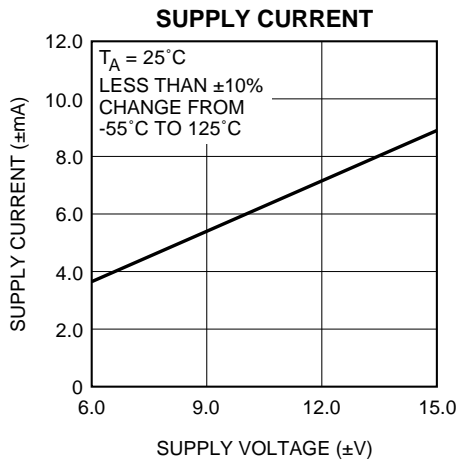
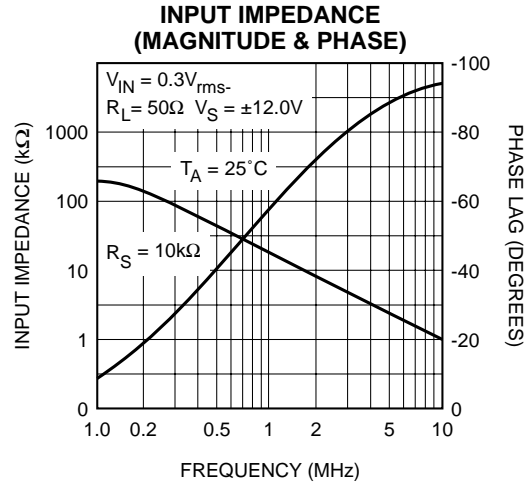
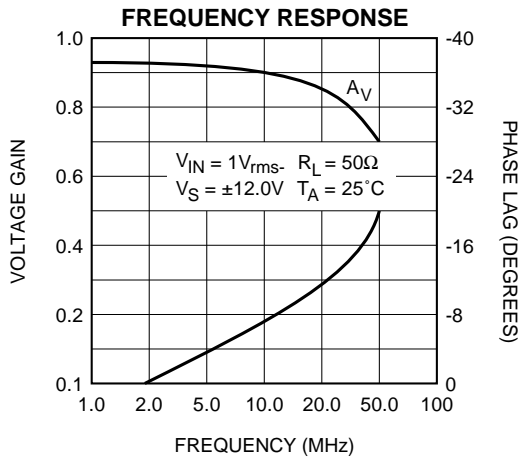

TYPICAL APPLICATIONS

FIGURE 1. Coaxial Cable Drive Circuit

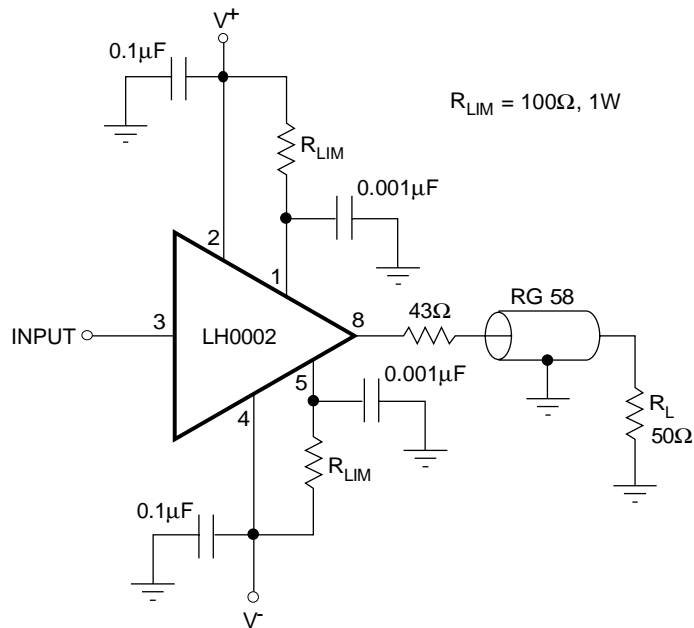
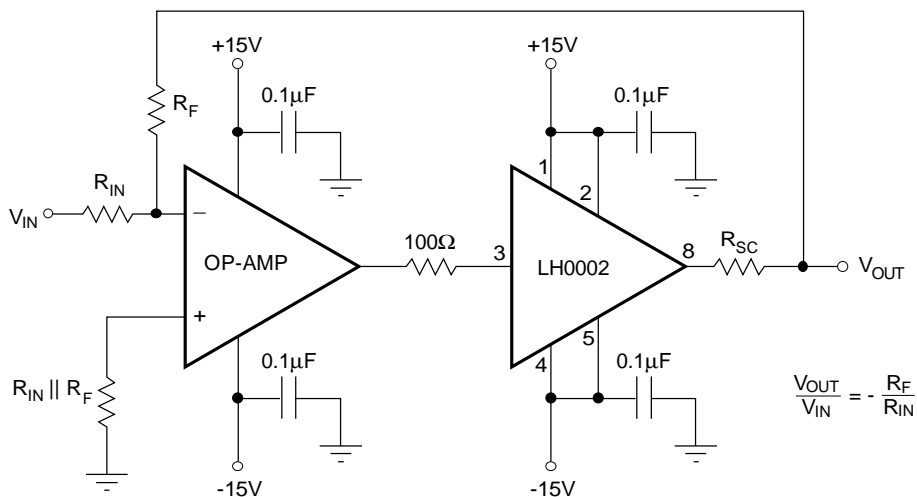

FIGURE 2. Inverting Buffer Amplifier with Current Limit



$$\frac{V_{OUT}}{V_{IN}} = - \frac{R_F}{R_{IN}}$$

TYPICAL APPLICATIONS (Continued)

FIGURE 3. Non-Inverting Buffer Amplifier with Gain

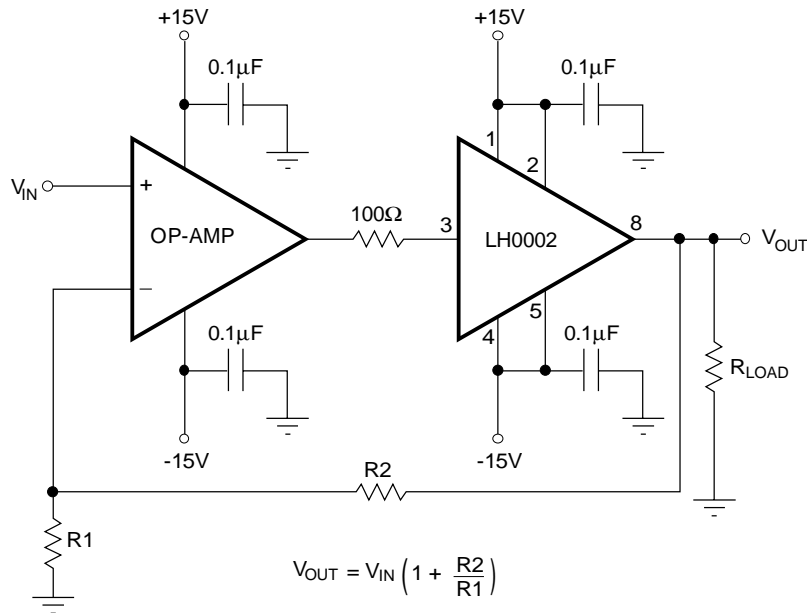
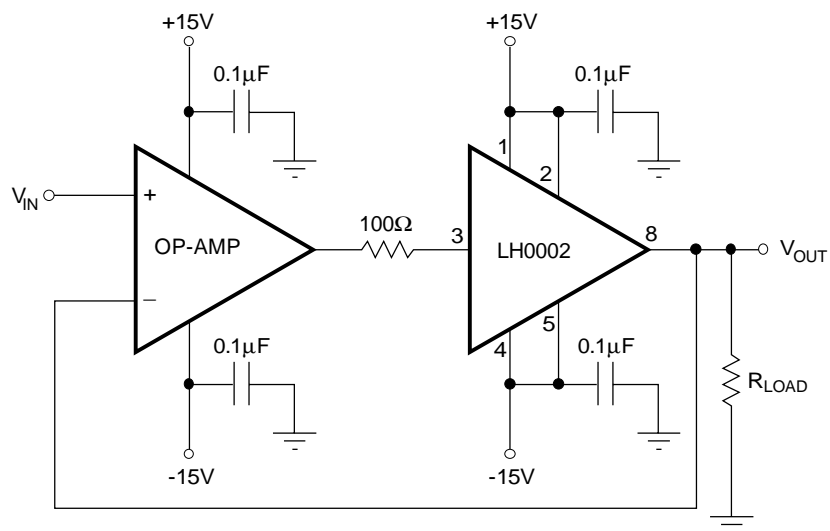

FIGURE 4. Non-Inverting Buffer Amplifier



TYPICAL APPLICATIONS (Continued)

FIGURE 5. LH0002 Using Resistor Current Limiting

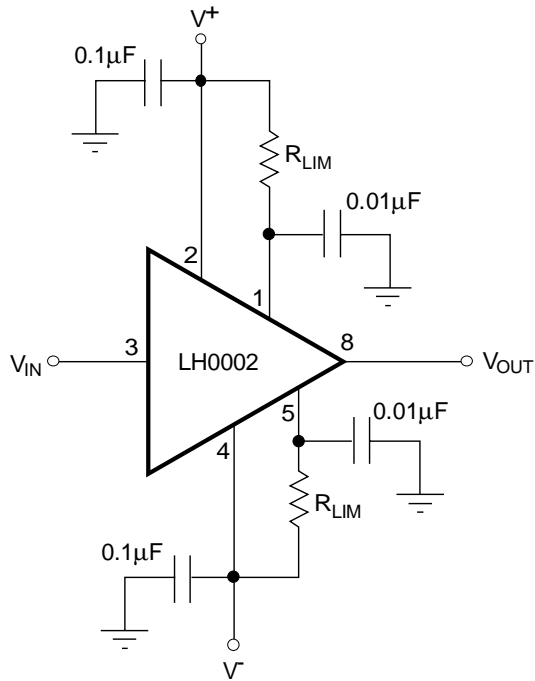

FIGURE 6. Current Limit Using Current Source

