

# Two-channel VCR PRE / REC amplifier for Digital VCRs

## BH7272KV

The BH7272KV is a head amplifier developed for use in digital video cassette recorders. Both PB and REC have excellent frequency characteristics making this IC an ideal choice for digital recording and playback. The small VQFP48 package facilitates compact design of portable equipment such as video cameras.

### ●Applications

Digital video cassette recorders

### ●Features

- 1) The playback amplifier is a differential amplifier with an overall gain of 54dB (Typ.), and has low-noise transistors as the first stage. The feedback circuit is not included, so provide negative feedback for head peak damping, and positive feedback to cancel the input capacitance using external components.
- 2) The playback AGC amplifier has  $\pm 10$ dB of control range.
- 3) The recording current amplifier is a BLT current amplifier. Use external components to construct the head peak damping circuit.
- 4) Recording limit amplifier is included. Recording AGC amplifier not included.
- 5) The signal system  $V_{cc}$  is 4.9V, and the control system  $V_{cc}$  is 3.0V.

### ●Absolute maximum ratings (Ta = 25°C)

Parameter	Symbol	Limits	Unit
Applied voltage	$V_{cc}$	7.0	V
Power dissipation	$P_d$	*900	mW
Operating temperature	$T_{opr}$	- 20 ~ + 65	°C
Storage temperature	$T_{stg}$	- 55 ~ + 125	°C

\* When mounted on a 70mm × 70mm × 1.6mm glass epoxy board.

\* Reduced by 9.0mW for each increase in Ta of 1°C over 25°.

### ●Recommended operating conditions (Ta = 25°C)

Parameter	Symbol	Min.	Typ.	Max.	Unit	Conditions
Signal system	$V_{cc}$ 5V	4.6	4.9	5.2	V	14, 19, 38, 47pin
Control system	$V_{cc}$ 3V	2.8	3.0	3.2	V	16pin

○Not designed for radiation resistance.

●Block diagram

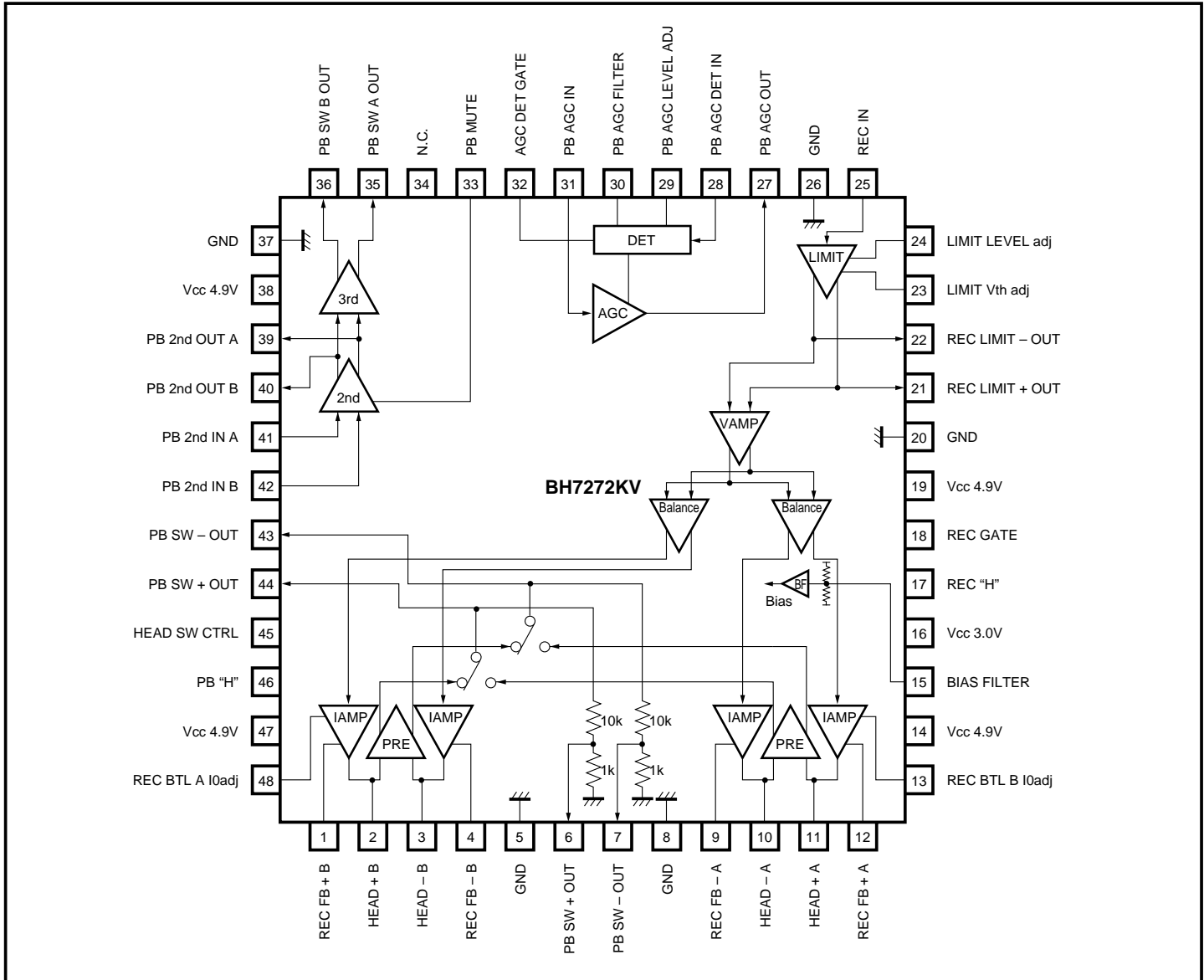

●Vcc / GND pins

Pin No.	Pin name	Function
14	Vcc 4.9V	REC current amplifier
8	GND	As above
19	Vcc 4.9V	Bias, REC limiter amplifier
20	GND	Bias, control logic
26	GND	REC limiter amplifier
38	Vcc 4.9V	PB amplifier, PB AGC, peak amplifier
37	GND	As above
47	Vcc 4.9V	PB first-stage amplifier
5	GND	PB first-stage amplifier, REC current amplifier
16	Vcc 3.0V	Control logic

\* Make sure that the voltages at Vcc and GND pins does not sway.

\* Be especially careful of the Vcc and GND for the first-stage amplifier.

\* The playback system has high gain, so take care to ensure that the output does not find its way back to the input.

## ●Electrical characteristics (unless otherwise noted, Ta = 25°C, VCC = 4.9V, 3.0V and f = 4.0MHz)

Parameter	Symbol	Min.	Typ.	Max.	Unit	Conditions
〈Playback system〉						
Sleep-mode circuit current	I <sub>q (S)</sub>	—	14	30	mA	No signal
Circuit current	I <sub>q (P)</sub>	—	34	56	mA	No signal
Voltage gain ch-1	G <sub>VP1</sub>	50	54	58	dB	Pin 35 output measurement when pin 11 input is 0.3mV <sub>P-P</sub>
Voltage gain ch-2	G <sub>VP2</sub>	50	54	58	dB	Pin 35 output measurement when pin 2 input is 0.3mV <sub>P-P</sub>
Voltage gain differential	ΔG <sub>VP</sub>	-1.5	—	+1.5	dB	ΔG <sub>VP</sub> = G <sub>VP1</sub> - G <sub>VP2</sub>
Frequency characteristics	ΔG <sub>Vf</sub>	-3.0	±0.0	—	dB	Pin 35 output level differential when f = 8.0 / 1.0MHz and V <sub>IN</sub> = 0.3mV <sub>P-P</sub>
Crosstalk	CT <sub>P</sub>	—	-46	-35	dBc	Pin 35 output level differential when for pin 45: H / L
PB mute attenuation	MU <sub>P</sub>	—	-57	-35	dBc	Pin 35 output level differential when pin 33 goes from L to H and pin 2 input is 0.3mV <sub>P-P</sub>
AGC output level	V <sub>AGC</sub>	230	280	330	mV <sub>P-P</sub>	Pin 27 output measurement when pin 31 input is V <sub>IN</sub> = 300mV <sub>P-P</sub>
AGC control sensitivity	ΔV <sub>AGC</sub>	—	0.2	2.0	dB	Pin 27 output level differential when pin 31 input V <sub>IN</sub> = 150 to 600mV <sub>P-P</sub>
AGC frequency characteristics	ΔG <sub>VAF</sub>	-3.0	±0.0	—	dB	Pin 27 output level differential when f = 8.0 / 1.0MHz and pin 31 input is V <sub>IN</sub> = 300mV <sub>P-P</sub>
〈Recording system〉						
Circuit current	I <sub>q (R)</sub>	—	54	80	mA	No signal
Recording current level 1	I <sub>OR1</sub>	14	20	26	mA <sub>P-P</sub>	Pin 11 output measurement when pin 25 input is 0.3V <sub>P-P</sub>
Recording current level 2	I <sub>OR2</sub>	14	20	26	mA <sub>P-P</sub>	Pin 2 output measurement when pin 25 input is 0.3V <sub>P-P</sub>
REC frequency characteristics	ΔI <sub>OF</sub>	-3.0	±0.0	—	dB	f = 8.0 / 1.0MHz, pin 25 input = 0.3V <sub>P-P</sub>
REC mute attenuation	MU <sub>R</sub>	—	-60	-35	dBc	Pins 2, 11 output level differential
〈Logic system〉						
PB holding voltage	V <sub>TH46H</sub>	2.0	—	3.0	V	Pins 46 voltage to hold PB
PB holding voltage	V <sub>TH46L</sub>	0.0	—	1.0	V	Pin 46 voltage to hold $\overline{\text{PB}}$
REC holding voltage	V <sub>TH17H</sub>	2.0	—	3.0	V	Pin 17 voltage to hold REC
REC holding voltage	V <sub>TH17L</sub>	0.0	—	1.0	V	Pin 17 voltage to hold $\overline{\text{REC}}$
HSW holding voltage	V <sub>TH45H</sub>	2.0	—	3.0	V	Pin 45 voltage to hold HSW
HSW holding voltage	V <sub>TH45L</sub>	0.0	—	1.0	V	Pin 45 voltage to hold $\overline{\text{HSW}}$
RECGATE holding voltage	V <sub>TH18H</sub>	2.0	—	3.0	V	Pin 18 voltage to hold RECGATE
RECGATE holding voltage	V <sub>TH18L</sub>	0.0	—	1.0	V	Pin 18 voltage to hold $\overline{\text{RECGATE}}$

\* Note: dBc: dB below carrier (used to express relative level from carrier reference for convenience sake)

● Measurement circuit (playback system)

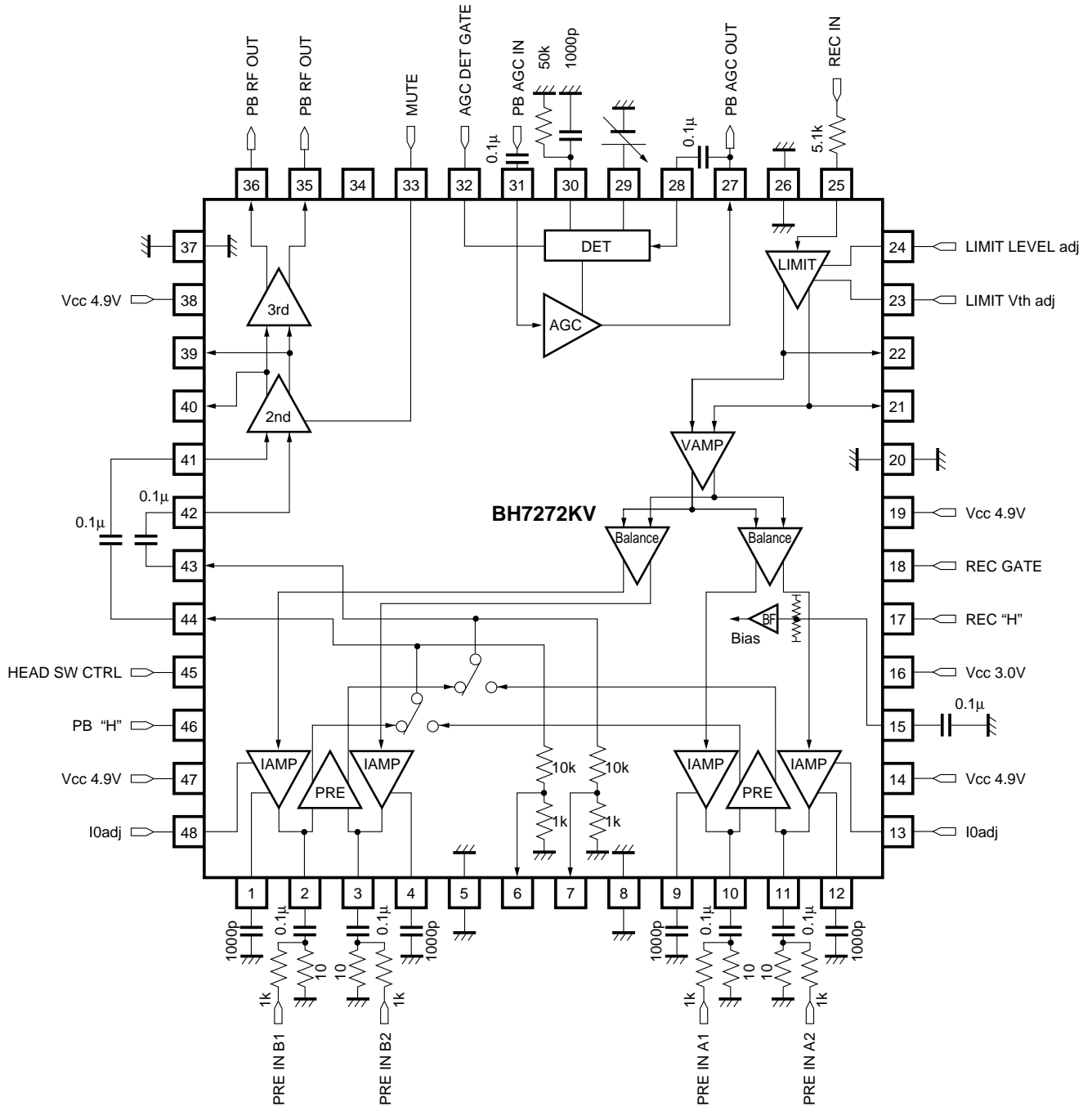

Fig. 1

● Measurement circuit (recording system)

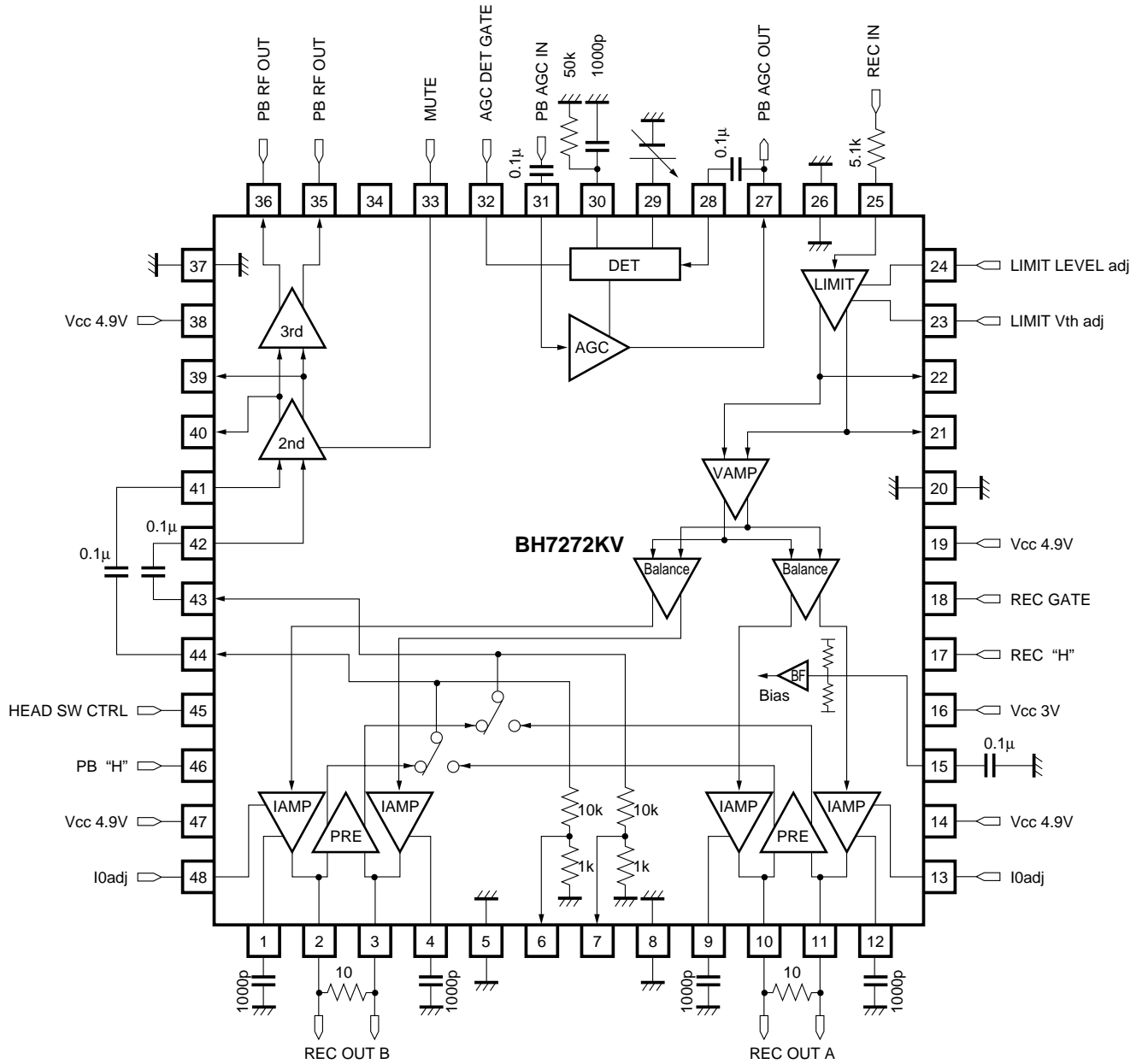

Fig. 2

●Circuit operation

(1) Control logic table

Mode	Control signals				Circuit operation					
	PB-H 46pin	REC-H 17pin	HSW 45pin	REC GATE 18pin	REC	REC-A	REC-B	PB	PB-A	PB-B
REC PAUSE	L	L	×	×	×	×	×	×	×	×
REC	L	H	L	L	1	×	×	×	×	×
	L	H	L	H	1	×	1	×	×	×
	L	H	H	L	1	×	×	×	×	×
	L	H	H	H	1	1	×	×	×	×
PB	H	L	L	×	×	×	×	1	×	1
	H	L	H	×	×	×	×	1	1	×
After recording	H	H	L	L	1	×	×	1	×	1
	H	H	L	H	1	×	1	1	×	×
	H	H	H	L	1	×	×	1	1	×
	H	H	H	H	1	1	×	1	×	×
Notes	Low: 1V or less High: 2V or more ×: Irrelevant				1: Operating ×: Power save state					

(2) Mute circuit

	33pin	Operation
MUTE 33pin	L	MUTE OFF
	H	MUTE ON
Notes	Low: 1V or less High: 2V or more	—

(3) AGC DET GATE circuit

	32pin	Operation
AGC DET GATE 32pin	L	AGC detection on
	H	AGC detection off
Notes	Low: 1V or less High: 2V or more	—

● I / O circuits

Pin No.	Pin name	Pin voltage	Equivalent internal circuit	Function
1 2	REC FB + B HEAD + B	2.5 (2.5) 2.5 (2.5)		REC DC feedback HEAD B
3 4	HEAD - B REC FB - B	2.5 (2.5) 2.5 (2.5)		HEAD B REC DC feedback
5	GND	—	—	GND for PB 1st stage amplifier and REC current amplifier
6	PB SW + OUT	0.2 (-)		1st stage amplifier positive phase output PB feedback
7	PB SW - OUT	0.2 (-)		1st stage amplifier reverse phase output PB feedback
8	GND	—	—	GND for REC current amplifier

\* The pin voltages in brackets are for REC mode, all others are for PB mode.

Pin No.	Pin name	Pin voltage	Equivalent internal circuit	Function
9 10	REC FB – A HEAD – A	2.5 (2.5) 2.5 (2.5)		REC DC feedback HEAD A
11 12	HEAD + A REC FB + A	2.5 (2.5) 2.5 (2.5)		HEAD A REC DC feedback
13	REC BTL A I0adj	2.5 (3.4)		HEAD A recording current adjustment
14	V <sub>CC</sub> 5V	—	—	V <sub>CC</sub> for REC current amplifier
15	BIAS FILTER	2.5 (2.5)		Bias filter for head connection pins (pins 2, 3, 10, and 11)
16	V <sub>CC</sub> 3V	—	—	V <sub>CC</sub> for logic circuits

\* The pin voltages in brackets are for REC mode, all others are for PB mode.



Pin No.	Pin name	Pin voltage	Equivalent internal circuit	Function
17	REC "H"	0.0 (0.0)		Mode control
18	REC GATE	0.0 (0.0)		Mode control
19	V <sub>CC</sub> 5V	—	—	V <sub>CC</sub> for bias and REC limiter amplifier
20	GND	—	—	GND for bias and control logic
21	REC LIMIT + OUT	2.5 (2.5)		REC limiter amplifier positive phase output
22	REC LIMIT - OUT	2.5 (2.5)		REC limiter amplifier reverse phase output
23	LIMIT V <sub>th</sub> adj	— (1.5)		REC limiter amplifier input threshold level adjustment

\* The pin voltages in brackets are for REC mode, all others are for PB mode.

Pin No.	Pin name	Pin voltage	Equivalent internal circuit	Function
24	REC LEVEL adj	1.5 (1.5)		REC limiter amplifier output level adjustment
25	REC IN	— (1.5)		REC input
26	GND	—	—	GND for REC limiter amplifier
27	PB AGC OUT	2.4 (-)		Playback system AGC output
28 29	PB AGC DET IN PB AGC LEVEL adj	2.5 (-) 3.6 (3.6)		Playback system AGC detector input Playback system AGC level adjustment
30	PB AGC FILTER	— (-)		Playback system AGC filter
31	PB AGC IN	2.5 (-)		Playback system AGC input

\* The pin voltages in brackets are for REC mode, all others are for PB mode.

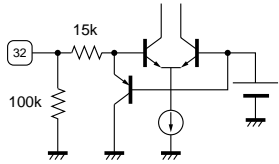
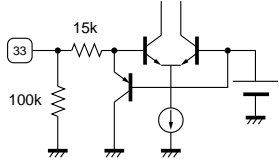
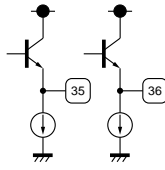
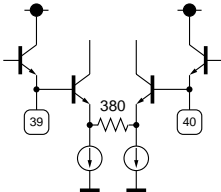
Pin No.	Pin name	Pin voltage	Equivalent internal circuit	Function
32	PB AGC GATE	0.0 (0.0)		PB AGC detection control
33	MUTE	0.0 (0.0)		Playback system mute control
34	N.C.	—	—	—
35 36	PB SW A OUT PB SW B OUT	3.2 (-) 3.2 (-)		Playback system amplifier output
37	GND	—	—	GND for PB amplifier, AGC, and peak amplifier
38	V <sub>CC</sub> 5V	—	—	V <sub>CC</sub> for PB amplifier, AGC, and peak amplifier
39 40	PB2nd OUT B PB2nd OUT A	2.5 (-) 2.5 (-)		Playback system 2nd amplifier output Playback system 2nd amplifier output

\* The pin voltages in brackets are for REC mode, all others are for PB mode.

Pin No.	Pin name	Pin voltage	Equivalent internal circuit	Function
41 42	PB2nd IN A PB2nd IN B	2.5 (-) 2.5 (-)		Playback system 2nd amplifier input Playback system 2nd amplifier input
43	PB SW + OUT	2.0 (-)		1st stage amplifier positive phase output
44	PB SW - OUT	2.0 (-)		1st stage amplifier reverse phase output
45	HSW	0.0 (0.0)		Mode control
46	PB "H"	0.0 (0.0)		Mode control
47	Vcc 5V	—	—	Vcc for PB 1st stage amplifier
48	REC BTL B I0adj	2.5 (3.4)		HEAD B recording current adjustment

\* The pin voltages in brackets are for REC mode, all others are for PB mode.

●Application example

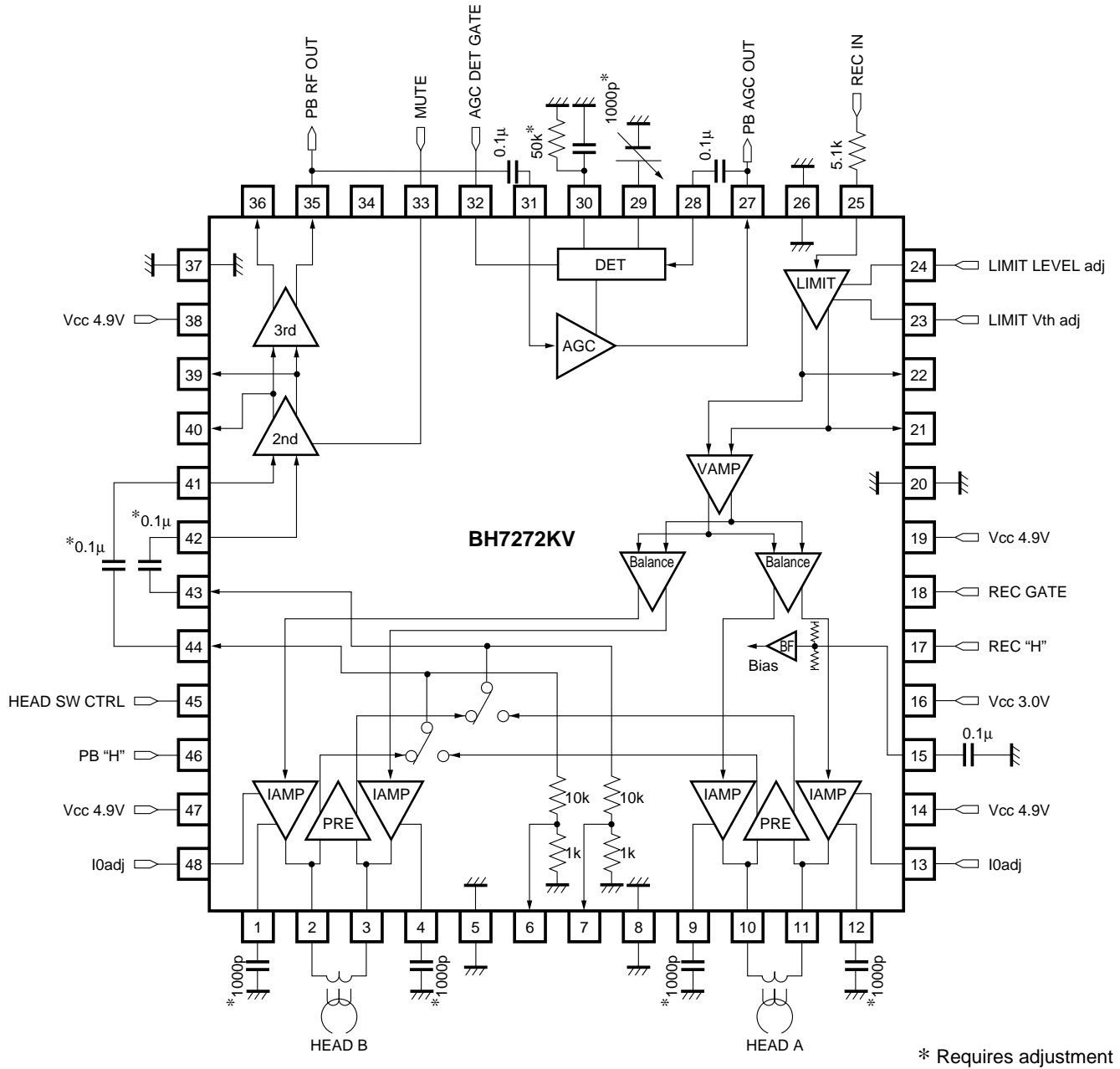

Fig. 3

●External dimensions (Units: mm)

