

Technical Data

MC44C401
Rev. 1.1 02/2004

MC44C401
MTS Stereo Encoder



MC44C401



Ordering Information		
Device	Temp. Range	Package
MC44C401FA	0°C to 70°C	32TQFP

Freescale Semiconductor, Inc.

Contents

1 Features 1
 2 Reference Documentation 2
 3 Block Diagrams 3
 4 I/O Description 5
 5 Electrical Specifications 6
 6 Package Data 8
 7 Functional Description 10
 8 Calibration 11

The MC44C401 Multi-Channel Television Sound (MTS) Stereo Encoder is the industry's first, single-chip, CMOS implementation of a Broadcast Television Systems Committee (BTSC)-compatible stereo encoder.

The MC44C401 MTS Stereo Encoder is designed for use in set-top boxes, VCRs, DVD players/recorders, game stations, and other applications that are required to output high-quality stereo sound through a single RF coaxial cable.

The digital audio processing used in the MC44C401 preserves the full fidelity of surround sound and other audio coding schemes while ensuring overall system performance is not impacted by copy protection technologies.

The MC44C401 is engineered to process right and left analog audio signals and base-band composite video to generate a stereophonic composite signal in accordance with BTSC system standards. The MC44C401 is designed to output this signal to a Motorola RF modulator, which in turn produces a stereo encoded RF channel for use with any BTSC stereo television receiver.

1 Features

- Integrated A/D input and D/A output circuitry
- CEX™ digital audio processing encodes and transports stereo signals
- Surround sound and Macrovision™ compatible
- Extended low frequency response (The MC44C401 frequency response extends below 25 Hz)

- Simple passive interface to Motorola's MC44BC374 (UHF/VHF) and MC44BC375 (VHF) modulators
- Preservation of original surround sound fidelity
- System performance not impacted by copy protection technologies
- Enables lower system component count, smaller board size, and significantly lower overall system cost
- Eliminates manual alignment of filters, phase controls, and composite signal amplitude

2 Reference Documentation

- "Multichannel Television Sound Transmission and Audio Processing Requirements for the BTSC System", FCC OET Bulletin No. 60, February 1986.

3 Block Diagrams

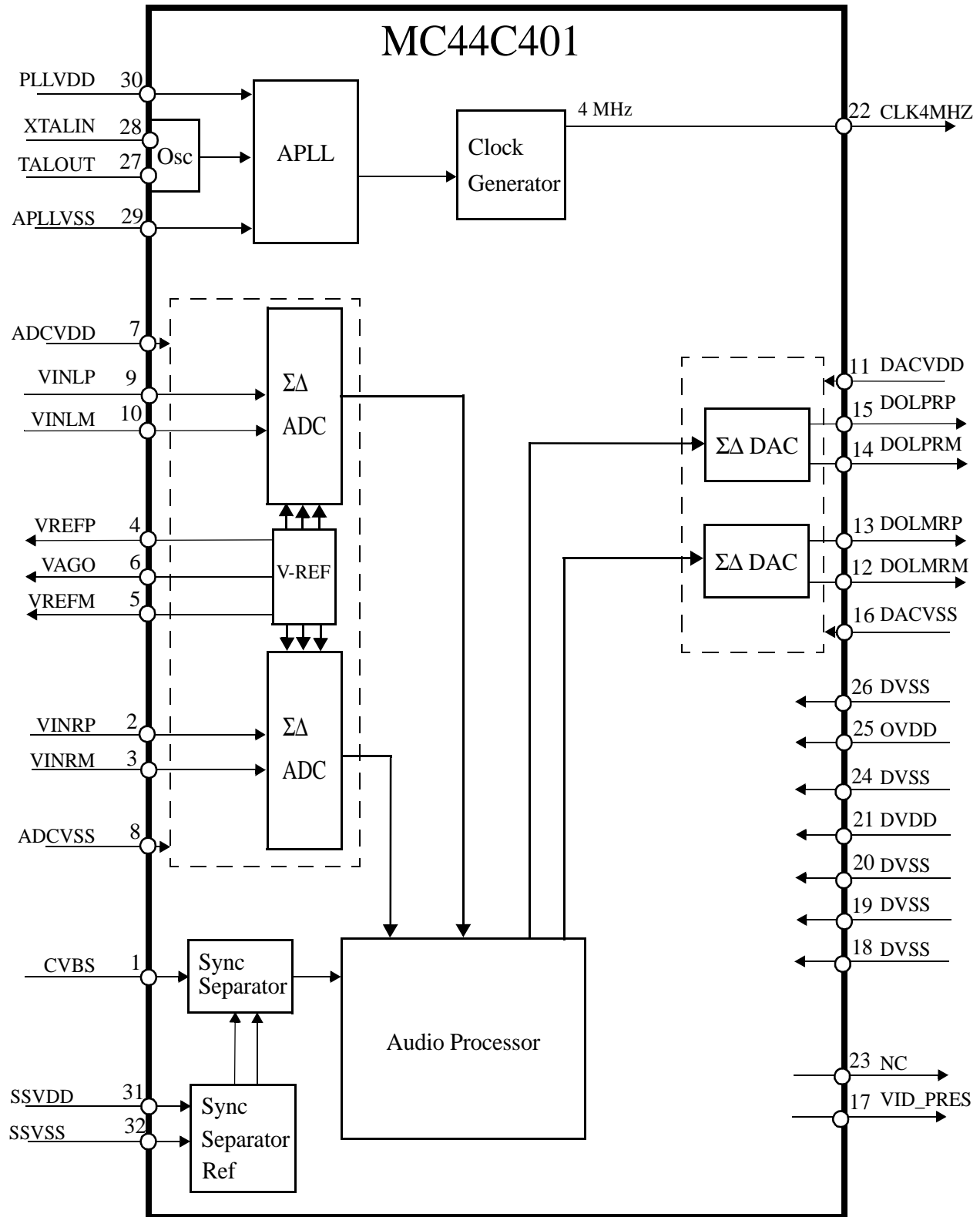

Figure 1. MC44C401 Block Diagram

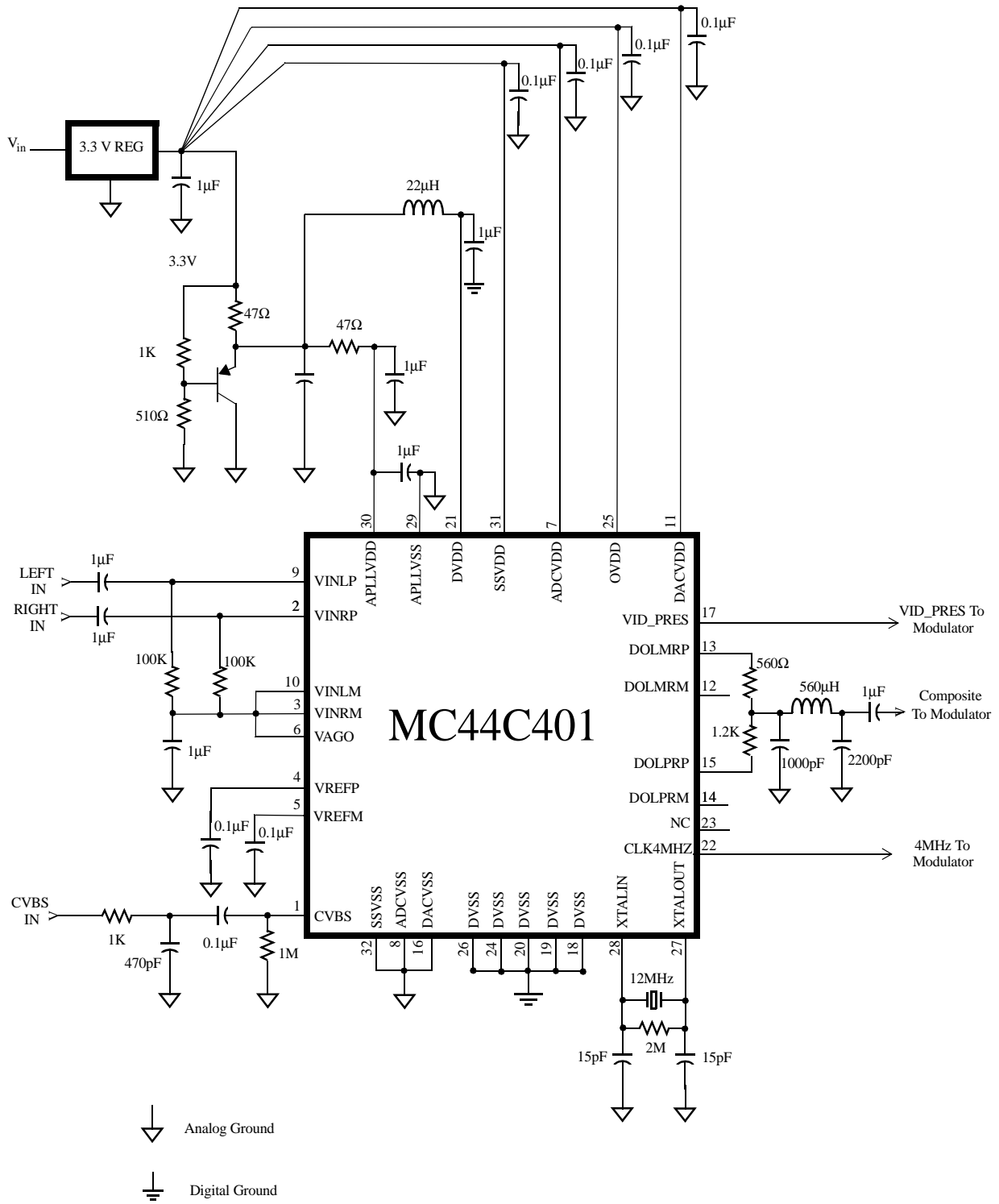

Figure 2. MC44C401 Recommended Usage

4 I/O Description

4.1 Signal List

The Stereo Modulator I/O signals are described in Table 1.

Table 1. MC44C401 Signal Descriptions

Signal	Pin #	Description
Analog		
VINLP	9	Left channel input voltage plus
VINLM	10	Left channel input voltage minus
VREFP	4	Left & Right ADC ref. input voltage plus
VAGO	6	Left & Right ADC analog virtual ground
VREFM	5	Left Right ADC ref. input voltage minus
VINRP	2	Right channel input voltage plus
VINRM	3	Right channel input voltage minus
CVBS	1	Composite video input
Digital		
DOLPRP	15	Left+Right channel output voltage plus
DOLPRM	14	Left+Right channel output voltage minus
DOLMRP	13	Left-Right channel output voltage plus
DOLMRM	12	Left-Right channel output voltage minus
VID_PRES	17	Video present flag, 0 = no video, hi-z = video present
NC	23	NC
Clocks		
XTALIN	28	Crystal input
XTALOUT	27	Crystal output
CLK4MHZ	22	4 MHz clock for Audio/Video modulator IC
Power Supply		
APLLVDD	30	APLL analog supply voltage, 1.8 V
APLLVSS	29	APLL analog ground
SSVDD	31	Sync Separator analog supply voltage, 3.3 V

Table 1. MC44C401 Signal Descriptions (Continued)

Signal	Pin #	Description
SSVSS	32	Sync Separator analog ground
ADCVDD	7	ADC analog supply voltage, 3.3 V
ADCVSS	8	ADC analog ground
DACVDD	11	DAC I/O supply voltage, 3.3 V
DACVSS	16	DAC I/O ground
DVDD	21	Digital Logic supply voltage, 1.8 V
DVSS	18, 19, 20, 24, 26	Digital Logic/I/O ground
OVDD	25	I/O supply voltage, 3.3 V

5 Electrical Specifications

5.1 DC Characteristics

Table 1. MC44C401 DC Characteristics (Preliminary)

PIN	Symbol	Parameter	Min	Typ	Max	Unit
DVDD	—	1.8 V Digital Logic	1.62	1.80	1.98	V
DVDD	—	1.8 V Digital Logic	—	18.0	22.0	mA
OVDD	—	3.3 V Digital Output	2.97	3.30	3.63	V
OVDD	—	3.3 V Digital Output	—	2.0	8.0	mA
DACVDD	—	3.3 V DAC Supply	2.97	3.30	3.63	V
DACVDD	—	3.3 V DAC Supply	—	7.0	9.0	mA
ADCVDD	—	3.3 V ADC Supply	2.97	3.30	3.63	V
ADCVDD	—	3.3 V ADC Supply	—	7.0	9.0	mA
SSVDD	—	3.3 V Sync. Sep Supply	2.97	3.3	3.63	V
SSVDD	—	3.3 V Sync. Sep Supply	—	2.0	—	mA
APLLVDD	—	1.8 V APLL Supply	1.62	1.8	1.98	V
APLLVDD	—	1.8 V APLL Supply	—	3.0	—	mA
VREFP	—	Voltage Ref. Bypass plus	—	2.0	—	V
VREFM	—	Voltage Ref. Bypass minus	—	1.0	—	V

Table 1. MC44C401 DC Characteristics (Preliminary) (Continued)

PIN	Symbol	Parameter	Min	Typ	Max	Unit
VAGO	—	Voltage Ref. Ground	—	1.5	—	V
VINXX	V _{il}	Signal Input	VREFM		VREFP	V
VINXX	V _{ih}	Signal Input	VREFM		VREFP	V
CVBS		Video input (See Figure 2)	—	1	—	V _{pp}
CLK4MHZ	V _{ol}	4 MHz Clock Output @ I =.6 mA	2.97	—	—	V
CLK4MHZ	V _{oh}	4 MHz Clock Output @ I =.6 mA	—	—	3.63	V
DOLPRP	V _{ol} ^a	Output Left-plus-Right plus	—	2.2	—	V _{pp}
DOLPRP	V _{oh} ^b	Output Left-plus-Right plus	—	2.2	—	V _{pp}

- a. V_{ol} is measured at I_{load}= 6 mA (see test circuit Figure 2)
- b. V_{oh} is measured at I_{load}= 6 mA (see test circuit Figure 2)

5.2 AC Characteristics

Table 1. MC44C401 AC Characteristics (Preliminary) (See Figure 2)

SIGNALS	Symbol	Parameter ^a	Min	Typ	Max	Unit
LEFT/RIGHT IN	—	Input Level	—		1.0	V _{pp}
LEFT/RIGHT IN	—	Input Impedance	—	22	—	kΩ
COMPOSITE	—	Composite Output Level ^b	v	2.2	—	V _{pp}
COMPOSITE	—	Mono SNR ^c	65	75	—	dB
COMPOSITE	—	Stereo SNR ^c	55	65	—	dB
COMPOSITE	—	THD		0.1	0.3	%
COMPOSITE	—	-1 db Bandwidth	20	—	14000	Hz
CVBS IN	—	Video Level	0.5	—	2.0	V _{pp}
CVBS	Z _{in}	Video Input Impedance	—	1000	v	Ω
—	—	Stereo Separation 500Hz–5KHz	25	35	—	dB
—	—	Stereo Separation 100Hz–10KHz	20	30	—	dB

- a. See Figure 2 for test setup
- b. Test conditions 1 kHz 0 dB
- c. Measured in 20 Hz to 13.5 kHz bandwidth

6 Package Data

6.1 MC44C401 Package

The MC44C401 pin-outs (32TQFP package) are shown in Figure 3.

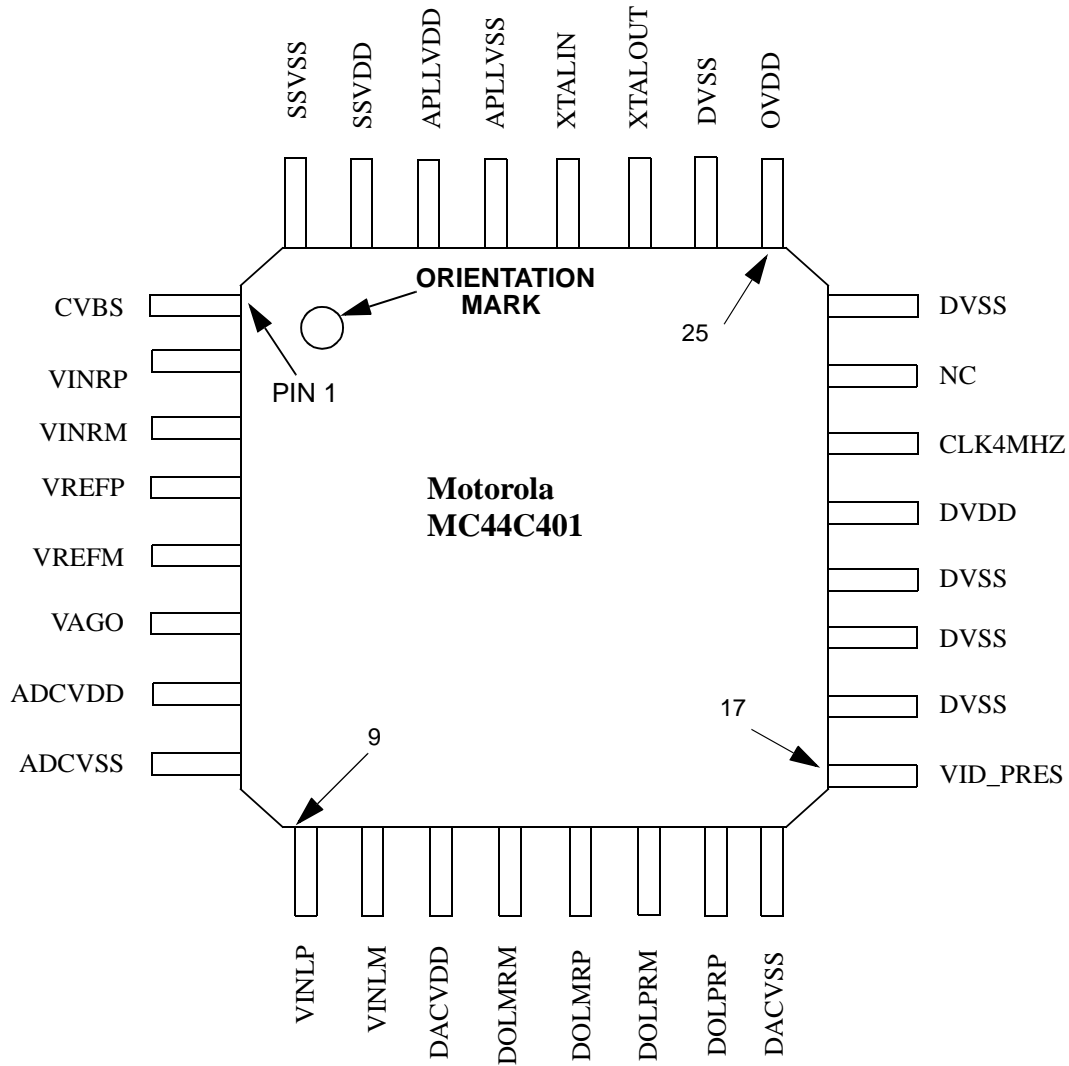

Figure 3. MC44C401 32TQFP Package

6.2 Mechanical Data

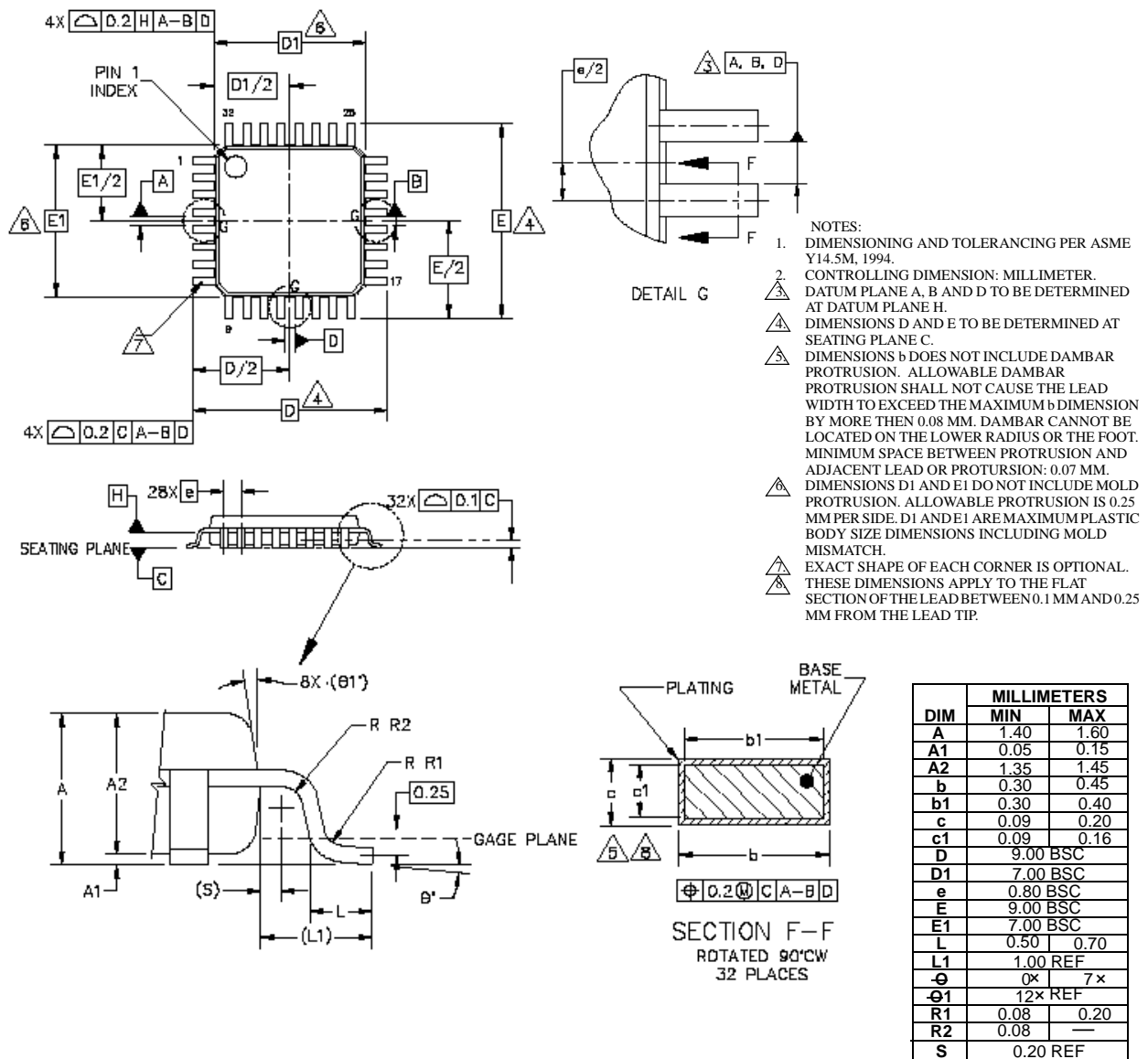

Figure 4. Package Mechanical Information

7 Functional Description

The following sections provide brief descriptions of the MC44C401 modules.

7.1 Phase Locked Loop (APLL)

The APLL locks to the reference frequency of 12 MHz and generates the master clock.

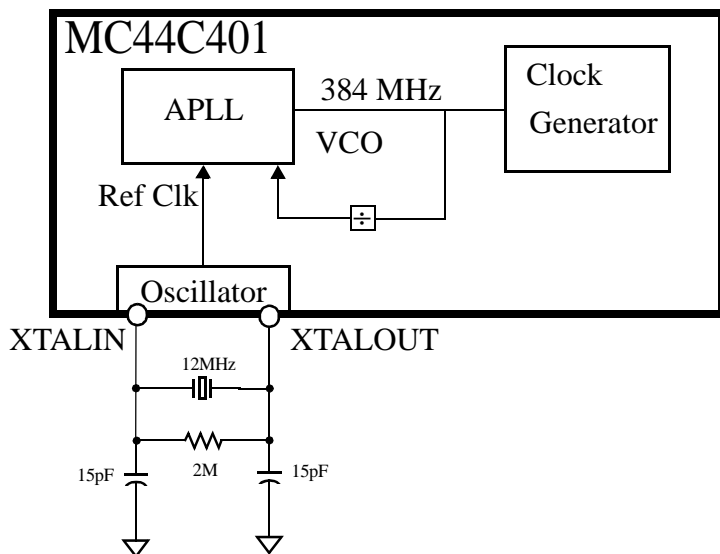

Figure 5. APLL and Clock Generator

7.2 Sync Separator

The Sync Separator, shown in Figure 6, extracts the composite sync from the incoming composite video signal.

The composite sync is used by the Audio Processor to generate the 15.734 kHz pilot tone and the 31.468 kHz carrier to modulate the Left-Right channel. The nominal output level of composite video signal sources is $1 V_{pp}$ on 75Ω and the sync amplitude is 0.3 V.

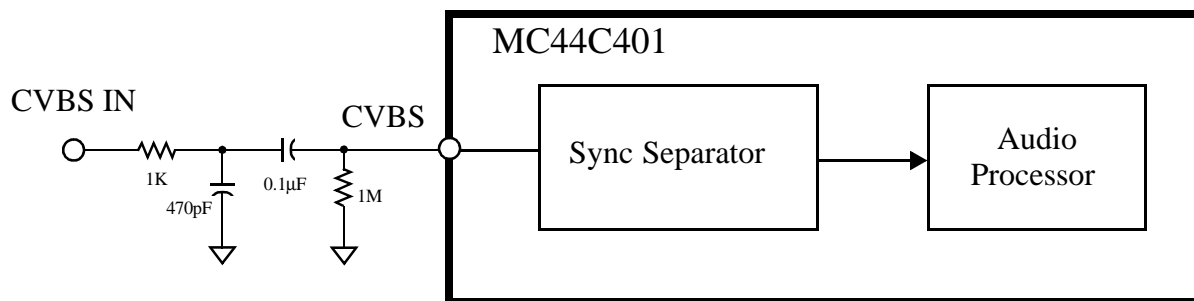

Figure 6. Sync Separator

8 Calibration

The following sections show methods for setting various output levels for optimum system performance.

8.1 Modulator Sensitivity

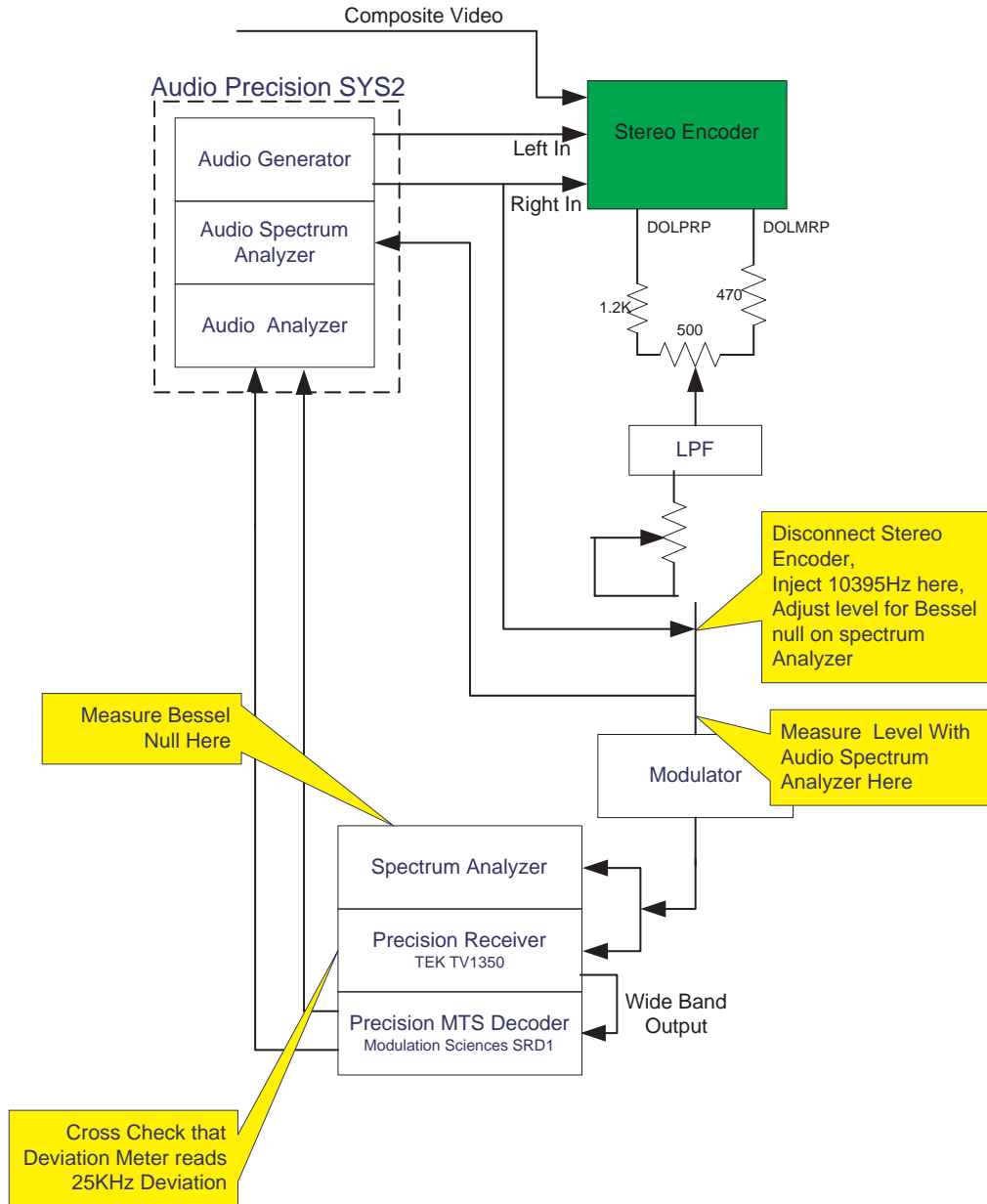

Figure 7. Measuring Modulator Sensitivity

8.2 Setting Output Levels

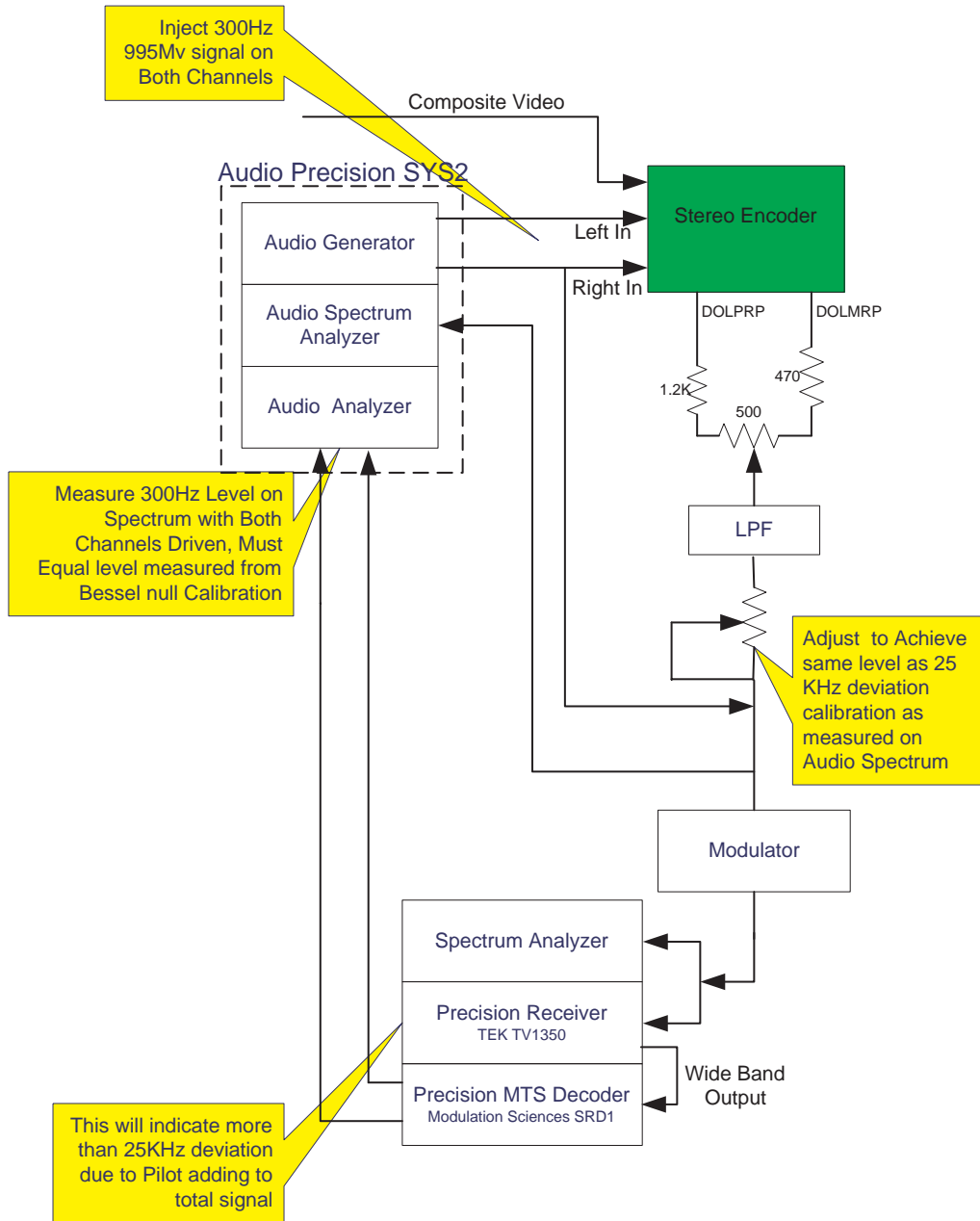

Figure 8. Setting Output Levels

8.3 Setting Sum/Difference Channels

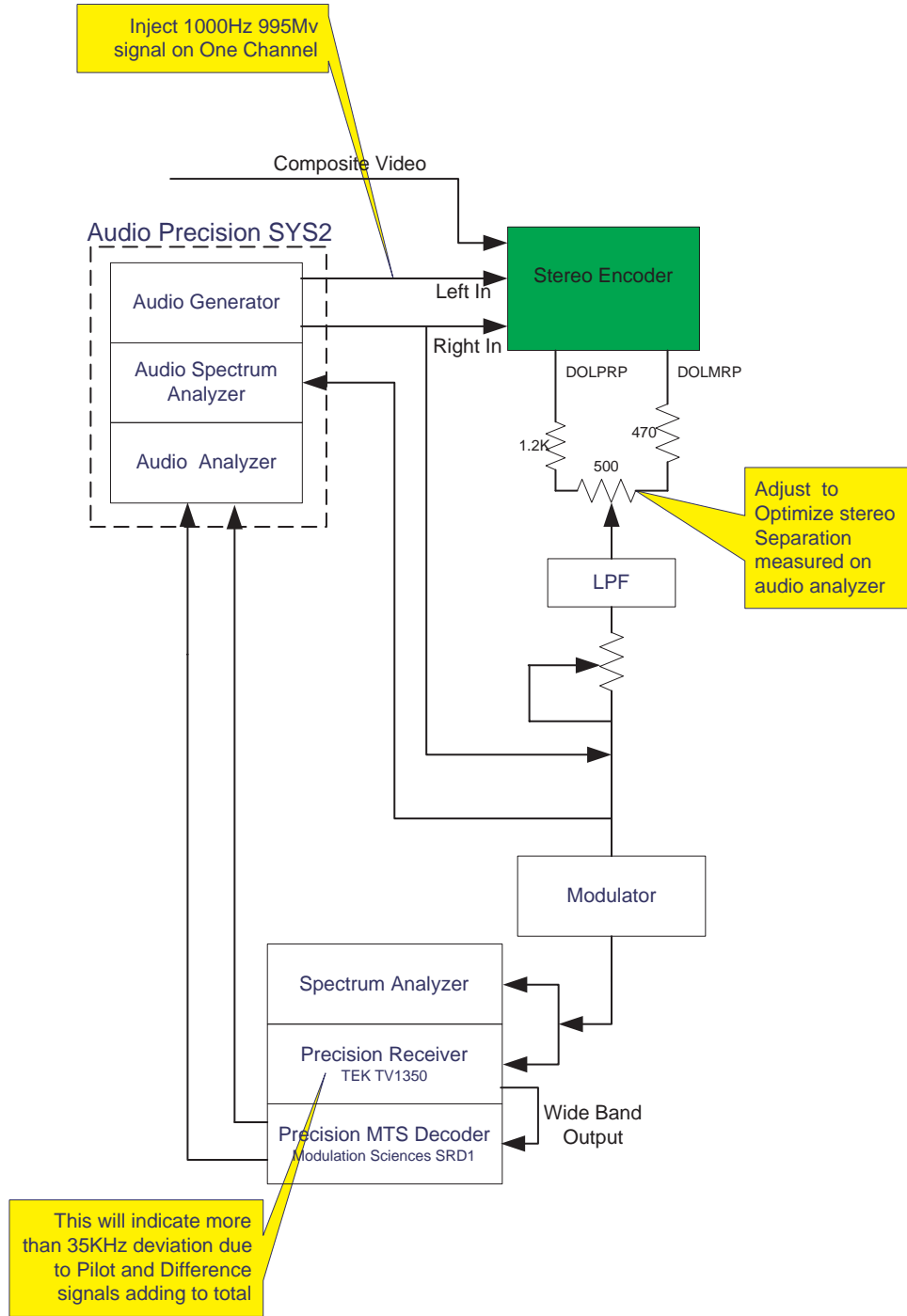

Figure 9. Setting Sum/Difference Channel Balance

THIS PAGE INTENTIONALLY LEFT BLANK

THIS PAGE INTENTIONALLY LEFT BLANK

Freescale Semiconductor, Inc.

Freescale Semiconductor, Inc.

HOW TO REACH US:

USA/EUROPE/LOCATIONS NOT LISTED:

Motorola Literature Distribution;
P.O. Box 5405, Denver, Colorado 80217
1-303-675-2140 or 1-800-441-2447

JAPAN:

Motorola Japan Ltd.; SPS, Technical Information Center,
3-20-1, Minami-Azabu Minato-ku, Tokyo 106-8573 Japan
81-3-3440-3569

ASIA/PACIFIC:

Motorola Semiconductors H.K. Ltd.; Silicon Harbour
Centre, 2 Dai King Street, Tai Po Industrial Estate,
Tai Po, N.T., Hong Kong
852-26668334

TECHNICAL INFORMATION CENTER:

1-800-521-6274

HOME PAGE:

<http://www.motorola.com/semiconductors>

Information in this document is provided solely to enable system and software implementers to use Motorola products. There are no express or implied copyright licenses granted hereunder to design or fabricate any integrated circuits or integrated circuits based on the information in this document.

Motorola reserves the right to make changes without further notice to any products herein. Motorola makes no warranty, representation or guarantee regarding the suitability of its products for any particular purpose, nor does Motorola assume any liability arising out of the application or use of any product or circuit, and specifically disclaims any and all liability, including without limitation consequential or incidental damages. "Typical" parameters which may be provided in Motorola data sheets and/or specifications can and do vary in different applications and actual performance may vary over time. All operating parameters, including "Typicals" must be validated for each customer application by customer's technical experts. Motorola does not convey any license under its patent rights nor the rights of others. Motorola products are not designed, intended, or authorized for use as components in systems intended for surgical implant into the body, or other applications intended to support or sustain life, or for any other application in which the failure of the Motorola product could create a situation where personal injury or death may occur. Should Buyer purchase or use Motorola products for any such unintended or unauthorized application, Buyer shall indemnify and hold Motorola and its officers, employees, subsidiaries, affiliates, and distributors harmless against all claims, costs, damages, and expenses, and reasonable attorney fees arising out of, directly or indirectly, any claim of personal injury or death associated with such unintended or unauthorized use, even if such claim alleges that Motorola was negligent regarding the design or manufacture of the part.



MOTOROLA

Motorola and the Stylized M Logo are registered in the U.S. Patent and Trademark Office. All other product or service names are the property of their respective owners. Motorola, Inc. is an Equal Opportunity/Affirmative Action Employer.

© Motorola, Inc. 2004

MC44C401

**For More Information On This Product,
Go to: www.freescale.com**