

L-band RF front-end for digital radio

Preliminary Data

Features

- Single chip receiver for satellite and terrestrial digital radio
- Super-heterodyne tuner with low IF output
- High input intercept point
- Low noise IC
- RF image rejection mixer
- Adjustable RF and IF gain
- 54 dB IF VGA gain range
- Integrated RF and IF VCOs
- Integrated synthesizers
- Low cost external components
- I²C-bus slave control interface
- Unregulated 2.7 to 3.3V supply voltage

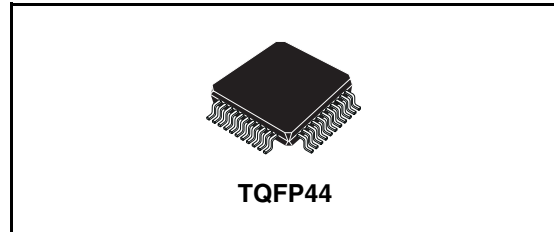

Description

The STA011 is an RF IC using STMicroelectronics BiCMOS6G high speed technology for one chip solution for the digital satellite radio receiver. The STA011 is assembled in a TQFP44 package. The front-end architecture is a double conversion receiver (see block diagram). The chip includes all the RF functions up to low IF and it manages the signals going to and coming from the base-band.

Table 1. Device summary

Order code	Package	Packing
STA011	TQFP44 (10x10x1.4mm) ⁽¹⁾	Tube

1. ECOPACK® (see [Chapter 8](#)).

Contents

1	Block diagram	6
2	Pins description	7
3	Electrical specifications	9
3.1	Absolute maximum/minimum ratings	9
3.2	Operating conditions	9
3.3	Thermal data	9
3.4	Electrical characteristics	10
4	Functional description	16
4.1	Receiver chain	16
4.2	Synthesizers, PLL, charge pump and VCOs	16
4.3	Power supplies	16
4.4	Interface specification	16
5	I²C-bus interface	17
5.1	I ² C-bus specifications	17
5.1.1	Power ON reset	17
5.1.2	Data validity	17
5.1.3	Start condition	17
5.1.4	Stop condition	17
5.1.5	Byte format	17
5.1.6	Acknowledge	17
5.1.7	Transmission without acknowledge	18
5.1.8	Device addressing	18
5.1.9	Write operation (single byte write)	18
5.1.10	Write operation (multibyte write)	18
5.1.11	Read operation	19
5.1.12	Timing specification	20
5.1.13	Start and stop	20
5.1.14	ACK	21
5.2	Software specification	22
5.2.1	Write mode (multibyte write)	22

5.3	Read mode	25
5.3.1	Bits description	25
6	Programming specifications	26
6.1	RFPLL	26
6.1.1	Loop divider division ratio	26
6.1.2	Reference divider division ratio	27
6.1.3	Blocks enable	27
6.1.4	VCO enable	28
6.1.5	VCO output voltage	28
6.1.6	Charge pump current setting	28
6.1.7	PFD programming	29
6.1.8	Fractional spurious compensation	29
6.2	RF path	30
6.2.1	Blocks enable	30
6.2.2	RF gain setting	30
6.2.3	IF buffer setting	30
6.3	IF path	31
6.3.1	Blocks disable	31
6.4	Lock detector setting	31
6.5	IF PLL	32
6.5.1	IFVCO enable	32
6.5.2	PFD programming	32
6.5.3	Charge pump enable	32
6.5.4	Reference divider division ratio	32
6.5.5	Loop divider division ratio	33
6.6	XTAL	33
6.7	Startup configuration	34
7	Evaluation board	35
8	Package information	36
9	Revision history	37

List of tables

Table 1.	Device summary	1
Table 2.	Pins description	7
Table 3.	Absolute maximum/minimum ratings	9
Table 4.	Operating conditions	9
Table 5.	Thermal data	9
Table 6.	Supply currents, ($T_{amb} = 25^{\circ}\text{C}$, $\text{VP-VN} = 3\text{V}$)	10
Table 7.	LNA, RF mixer and IF1 buffer, ($T_{amb} = 25^{\circ}\text{C}$, $\text{VP-VN} = 3\text{V}$)	10
Table 8.	IFVGA amplifiers, IF mixer and output buffer ($T_{amb} = 25^{\circ}\text{C}$, $\text{VP-VN} = 3\text{V}$)	11
Table 9.	Base-band output performance	13
Table 10.	Crystal oscillator, ($T=25^{\circ}\text{C}$, $\text{VP-VN}=3\text{V}$)	13
Table 11.	PLLs, Synthesizers, ($T_{amb} = 25^{\circ}\text{C}$, $\text{VP-VN} = 3\text{V}$)	13
Table 12.	RF VCO, ($T_{amb} = 25^{\circ}\text{C}$, $\text{VP-VN} = 3\text{V}$)	14
Table 13.	IF VCO, ($T_{amb} = 25^{\circ}\text{C}$, $\text{VP-VN} = 3\text{V}$)	14
Table 14.	Digital interface to MP (SCL,SDA,TLCK), ENRFOSC and XOSEL interface	14
Table 15.	Additional optional interface (REF)	15
Table 16.	Timing electrical characteristics	20
Table 17.	Start and stop electrical characteristics	21
Table 18.	ACK electrical characteristics	21
Table 19.	6th data byte	23
Table 20.	Reference divider division ratio	27
Table 21.	Blocks enable	27
Table 22.	VCO enable	28
Table 23.	VCO output voltage	28
Table 24.	Charge pump current	28
Table 25.	Frequency phase detector setting	29
Table 26.	Fractional spurious compensation	29
Table 27.	DAC current adjustment	29
Table 28.	Down Asym delay setting	29
Table 29.	Blocks enable	30
Table 30.	RF gain setting	30
Table 31.	IF Buffer setting	30
Table 32.	Blocks disable	31
Table 33.	Lock detector setting	31
Table 34.	IFVCO enable	32
Table 35.	Frequency phase detector setting	32
Table 36.	Charge pump enable	32
Table 37.	Reference divider division ratio	32
Table 38.	Loop divider division ratio	33
Table 39.	XTAL	33
Table 40.	Startup configuration	34
Table 41.	Document revision history	37

List of figures

Figure 1.	Block diagram	6
Figure 2.	Pins connection (top view)	7
Figure 3.	Typical IF overall gain vs control voltage	12
Figure 4.	System clock input/output	13
Figure 5.	Validity on I ² C-bus	19
Figure 6.	Timing diagram of the I ² C-bus	19
Figure 7.	Ack on I ² Cbus	20
Figure 8.	Data and clock	20
Figure 9.	Start and stop	20
Figure 10.	ACK	21
Figure 11.	Evaluation board schematic	35
Figure 12.	TQFP44 mechanical data and package dimensions	36

1 Block diagram

Figure 1. Block diagram

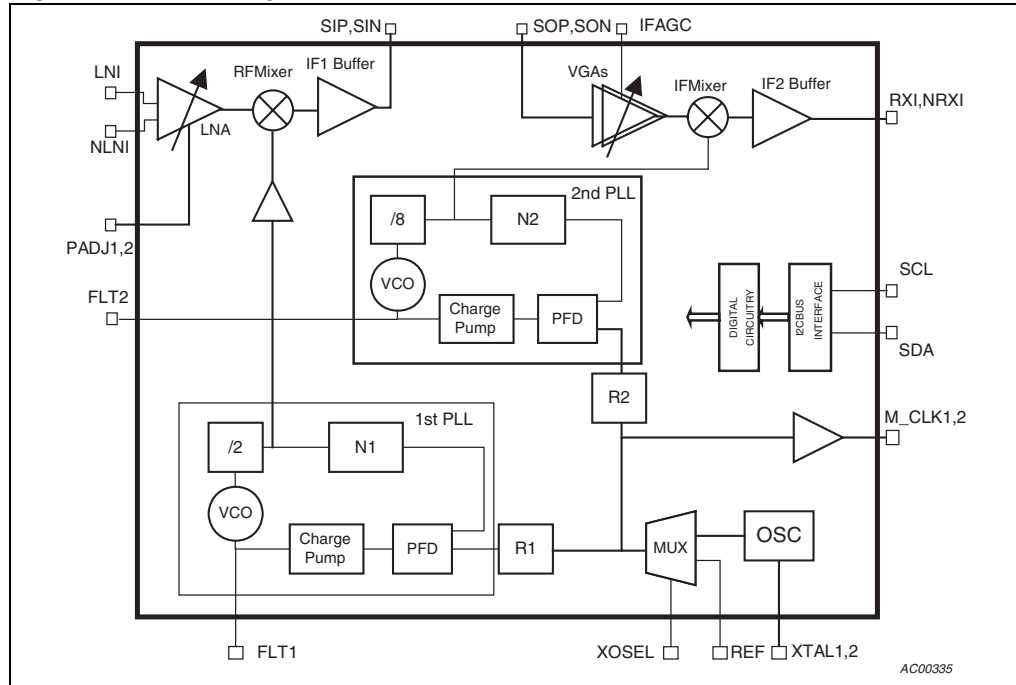

2 Pins description

Figure 2. Pins connection (top view)

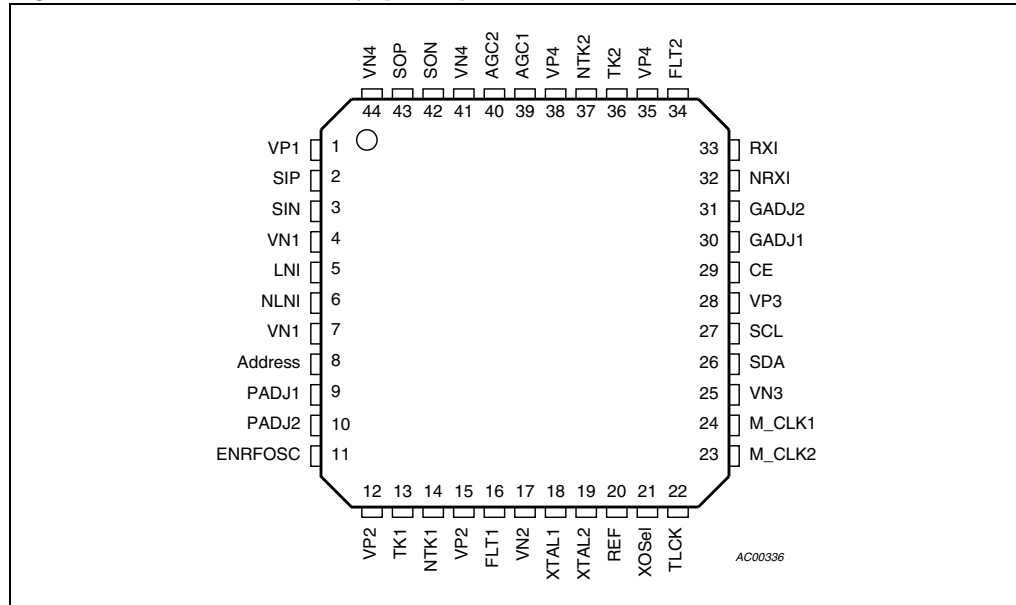

Table 2. Pins description

N.	Name	Function
1	VP1	Positive supply 1
2	SIP	SAW filter input connection
3	SIN	SAW filter input connection
4	VN1	Negative supply 1
5	LNI	RF input
6	NLNI	RF input
7	VN1	Negative supply 1
8	Address	Device address selection
9	PADJ1	RF gain adjust connection1
10	PADJ2	RF gain adjust connection2
11	ENRFOSC	RF oscillator hardware enable
12	VP2	Positive supply 2
13	TK1	External LO1 connection1
14	NTK1	External LO1 connection2
15	VP2	Positive supply 2
16	FLT1	1 st PLL loop filter connection
17	VN2	Negative supply 2

Table 2. Pins description (continued)

N.	Name	Function
18	XTAL1	Quartz oscillator connection 1
19	XTAL2	Quartz oscillator connection 2
20	REF	External optional TCXO input
21	XOSel	Internal/external XO selection
22	TLCK	Lock detector output
23	M_CLK2	Master Clock differential output2
24	M_CLK1	Master Clock differential output1
25	VN3	Negative supply 3
26	SDA	Data Serial Input
27	SCL	Clock Input
28	VP3	Positive supply 3
29	CE	Chip Enable
30	GADJ1	IF gain adjust connection 1
31	GADJ2	IF gain adjust connection 2
32	NRXI	Low IF Signal output 2
33	RXI	Low IF Signal output 1
34	FLT2	2 nd PLL loop filter connection
35	VP4	Positive supply 4
36	TK2	External LO2 connection1
37	NTK2	External LO2 connection2
38	VP4	Positive supply 4
39	AGC1	VGA control pin 1
40	AGC2	VGA control pin 2
41	VN4	Negative supply 4
42	SON	SAW filter negative output connection 2
43	SOP	SAW filter output connection 1
44	VN4	Negative supply 4

3 Electrical specifications

3.1 Absolute maximum/minimum ratings

Table 3. Absolute maximum/minimum ratings

Symbol	Parameter	Min.	Typ.	Max.	Unit
T_{stg}	Storage temperature	-40		125	°C
T_{op}	Operating ambient temperature	-40	25	85	°C
V_{Max}	Maximum voltage on each pin			3.6	V
V_{Min}	Minimum voltage on each pin	GND-0.3			V
V_{pmax}	Minimum/Maximum power supply Between $VP_{1,2,3,4}$ and $VN_{1,2,3,4}$	-0.3		3.6	
$V_{ESD,HBM}$	Electrostatic discharge Voltage (ESD, Human Body Model)			2	kV

3.2 Operating conditions

Table 4. Operating conditions

Symbol	Parameter	Test conditions/notes	Min.	Typ.	Max.	Unit
VP	Operating supply voltage		2.7		3.3	V
T_j	Junction temperature				125	°C

3.3 Thermal data

Table 5. Thermal data

Symbol	Parameter	Test conditions/notes	Min.	Typ.	Max.	Unit
$R_{th\ j-amb}$	Thermal resistance junction to ambient	According to JEDEC specification on a layers board		45		°C/W

3.4 Electrical characteristics

Table 6. Supply currents, ($T_{amb} = 25^{\circ}\text{C}$, VP-VN = 3V)

Symbol	Parameter	Test conditions/notes	Min.	Typ.	Max.	Unit
I_{CC1}	Current supplied by VP1	Powered circuits: LNA, RFMixer, IF buffer	12.5	17	21.5	mA
I_{CC2}	Current supplied by VP2	Powered circuits: RFVCO, divider by 2 and LO buffer	5.5	9	12.5	mA
		Powered circuits: external LO1, divider by 2 and LO buffer	11.5	15	18.5	
I_{CC3}	Current supplied by VP3	Powered circuits: Digital cells, Crystal oscillator (XOSel high)	5.5	7	11.5	mA
		Powered circuits: Digital cells, external REF (XOSel low)	3.5	6	8	
I_{CC4}	Current supplied by VP4	Powered circuits: VGAs, IFMixer, output buffer, IFPLL VAGC1=VAGC2=1.2V, IFgain=75dB	8.5	13	17.5	mA
I_{CCTOT}	$I_{CC1} + I_{CC2} + I_{CC3} + I_{CC4}$	CE = high, XOSel high, RFVCO enabled	36	46	56	mA
$I_{CCTOT,SB}$	Standby current	CE = low			20	μA

Table 7. LNA, RF mixer and IF1 buffer, ($T_{amb} = 25^{\circ}\text{C}$, VP-VN = 3V)

Symbol	Parameter	Test conditions/notes	Min.	Typ.	Max.	Unit
BW _i	Input signal BW		1452		1492	MHz
BW ₀	Output signal BW		114		116.5	MHz
G_V	Voltage gain	Input LNI, NLNI pins; output SIP, SIN pins. $R_L = 200\Omega$, PADj1,2 pins floating	26	30	34	dB
$G_{V,trim}$	Voltage gain	Input LNI, NLNI pins; output SIP,SIN pins. $R_L=200\Omega$, $R_{ext}=0$	19	25	29	dB
ΔG_V	Voltage gain variation	Programmable via software mode		2.5		dB
Z_i	Input impedance	Balanced @ LNi, NLNI pins, R//C		75 0.2		Ω pF
Z_o	Output impedance	Balanced @ SIP, SIN pins		50		Ω
γ	Return loss	LNI,NLNI pins		14		dB
NF	Noise figure	Measurements condition: Input LNI, NLNI pins; output SIP,SIN pins, $R_L=200\Omega$, PADj1,2 pins floating, $R_s=50\Omega$		5	7	dB

Table 7. LNA, RF mixer and IF1 buffer, ($T_{amb} = 25^{\circ}\text{C}$, $VP-VN = 3\text{V}$) (continued)

Symbol	Parameter	Test conditions/notes	Min.	Typ.	Max.	Unit
NF_{trim}	Noise figure @ minimum gain	Measurements condition: Input LNI, NLNI pins; output SIP,SIN pins, $R_L=200\Omega$, $R_{ext}=0$, $R_S=50\Omega$		6.5	8.5	dB
IIP3	Input IP3	Input LNI, NLNI pins; output SIP,SIN pins. $R_L=200\Omega$, PADj1,2 pins floating	-21	-17	-12	dBm
$IIP3_{trim}$	Input IP3 @ minimum gain	Input LNI, NLNI pins; output SIP,SIN pins. $R_L=200\Omega$, $R_{ext}=0$	-18	-14.5	-7	dBm
1dB C.P.	1dB compression point	Input LNI, NLNI pins; output SIP,SIN pins. $R_L=200\Omega$, PADj1,2 pins floating	-29	-26		dBm
1dB C.P. _{trim}	1dB compression point	Input LNI, NLNI pins; output SIP,SIN pins. $R_L=200\Omega$, $R_{ext}=0$	-27	-24		dBm
IR	Image rejection	RFin = LO-IF	15			dB
$REXT_{trim}$	REXT usable range	Connected between PADJ1 and PADJ2, to obtain intermediate gain between min and max	10		100	k Ω
$IF1_{leak}$	LO1 to IF1 leakage				-24	dBm
RF_{leak}	LO1 to RF leakage				-29	dBm
$V_{DC,RFin}$	LNI,NLNI common mode DC voltage	AC coupled to the balun	VP-1.3	VP-1.1	VP-0.9	V
$V_{DC,IFout}$	SIP,SIN common mode DC voltage	AC coupled to the SAW filter	VP-1.45	VP-1.2	VP-0.95	V

Table 8. IFVGA amplifiers, IF mixer and output buffer ($T_{amb} = 25^{\circ}\text{C}$, $VP-VN = 3\text{V}$)

Symbol	Parameter	Test conditions/notes	Min.	Typ.	Max.	Unit
BWi	Input signal BW		114		116.5	MHz
BWo	Output BW		0.6		3.1	MHz
G_{min}	Minimum gain	Input SOP, SON pins; output RXI,RXIN pins, RLoad high impedance, $VAGC_{1,2} = 0\text{V}$		32	38	dB
G_{max}	Maximum gain	Input SOP, SON pins; output RXI,RXIN pins, RLoad high impedance, $VAGC_{1,2} = 3\text{V}$	80	86		dB
I_{AGC}	Input current in AGC pin				10	μA
Z_{AGC}	AGC input impedance		150	600		k Ω

Table 8. IFVGA amplifiers, IF mixer and output buffer ($T_{amb} = 25^{\circ}\text{C}$, $V_P\text{-}V_N = 3\text{V}$) (continued)

Symbol	Parameter	Test conditions/notes	Min.	Typ.	Max.	Unit
NF	Noise Figure	Measurements condition: Input SOP, SON pins; output RXI, NRXI pins, $R_s=50\Omega$, Double Side Band, IFGain=65dB		9	12	dB
1dB cp	1dB compression point	Gain=65dB	-53	-50		dBm
1dB cp _{fg}	1dB compression point, full gain	Gain=81dB	-69	-66		dBm
IIP3	Input IP3	Gain=65dB	-45	-41		dBm
IIP3 _{fg}	Input IP3	Gain=81dB	-61	-57		dBm
Z_{in}	Input impedance	Balanced @ SOP, SON,		50		Ω
Z_{out}	Output impedance	Balanced @ RXI, RXIN Corresponding to 1.75mA in each emitter follower		50		Ω
$V_{DC,IFin}$	SIP, SIN common mode DC voltage	AC coupled to the SAW filter	VP-1.3	VP-1.1	VP-0.9	V
$V_{DC,RXout}$	RXI,NRXI common mode DC voltage	AC coupled to the base-band	VP-2.1	VP-1.8	VP-1.65	V
$V_{DC,PADJ}$	PADJ1,2 common mode DC voltage		VP-0.3	VP-0.12	VP-0.5	V
Z_{adj}	Gain adjustment pins impedance	Balanced GADJ1, GADJ2 pins	650	800	950	W
BB_{leak}	LO2 to BB leakage	Obtained by using low pass filter at the output		-49	-30	dBm
$IF2_{leak}$	LO2 to IF1 leakage	Obtained by using SAW filter at the input		-44	-30	dBm

Figure 3. Typical IF overall gain vs control voltage

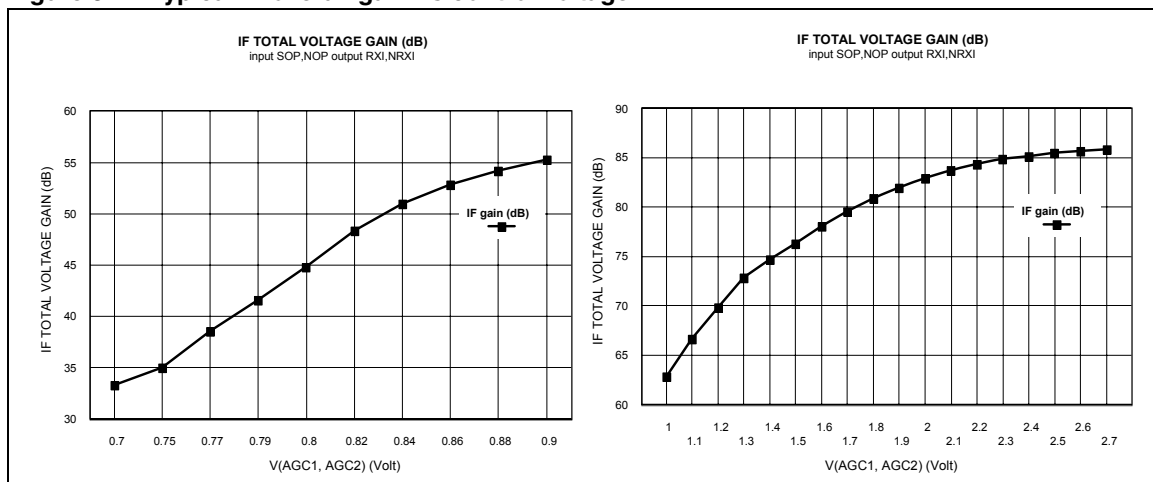

Table 11. PLLs, Synthesizers, ($T_{amb} = 25^{\circ}\text{C}$, $VP-VN = 3V$) (continued)

Symbol	Parameter	Test conditions/notes	Min.	Typ.	Max.	Unit
N_{prog1}	RF PLL selectable division ratios	From REF1 to LO1, $f_{comp}=3.68\text{MHz}$	360.75 (363.625 1 st used)		376.5 (373.75 last used)	
N_{prog2}	IF PLL selectable division ratios	$f_{comp}=113.23\text{KHz}$	987	1034	1081	
N_{REF1}	REF1 division ratio	Programmable via software mode	1	4	16	
N_{REF2}	REF2 division ratio	Programmable via software mode		130		

Table 12. RF VCO, ($T_{amb} = 25^{\circ}\text{C}$, $VP-VN = 3V$)

Symbol	Parameter	Test conditions/notes	Min.	Typ.	Max.	Unit
f_{osc}	VCO frequency oscillation		2676.28		2750.8	MHz
F_{LO1_1}	LO1 frequency range	after divider by 2, by using 14.72MHz crystal	1338.14		1375.4	MHz
F_{LO1_2}	LO1 frequency range	after divider by 2, by using 14.725MHz crystal	1338.134375 to 1375.407031			MHz
V_{FLT1}	Freq control voltage range	FLT1 pin	$VN+0.2$		$VP-0.2$	V

Table 13. IF VCO, ($T_{amb} = 25^{\circ}\text{C}$, $VP-VN = 3V$)

Symbol	Parameter	Test conditions/notes	Min.	Typ.	Max.	Unit
f_{osc}	VCO frequency oscillation		894.08	936.64	979.2	MHz
f_{LO2_1}	LO2 frequency range	after divider by 8, by using 14.72MHz crystal	111.76	117.08	122.4	MHz
f_{LO2_2}	LO2 frequency range	after divider by 8, by using 14.725MHz crystal	111.8	117.12	122.44	MHz
V_{FLT2}	Frequency control voltage range	FLT2 pin	$VN+0.2$		$VP-0.2$	V

Table 14. Digital interface to MP (SCL,SDA,TLCK), ENRFOSC and XOSEL interface
($T_{amb} = 25^{\circ}\text{C}$, $VP-VN = 3V$)

Symbol	Parameter	Test conditions/notes	Min.	Typ.	Max.	Unit
Input parameters (SCL, SDA, ENRFOSC, XOSEL)						
V_{IH}	Digital input signals	High	$VP-.7$		VP	V
V_{IL}		Low	VN		$VN+.7$	V
T_t	Input edge transition				0.1	$\mu\text{s/V}$
R_{in}	Input resistance			10		$\text{M}\Omega$

Table 14. Digital interface to MP (SCL,SDA,TLCK), ENRFOSC and XOSEL interface (continued)
 ($T_{amb} = 25^{\circ}\text{C}$, $V_P-V_N = 3\text{V}$)

Symbol	Parameter	Test conditions/notes	Min.	Typ.	Max.	Unit
Output parameter (TLCK)						
V_{OH}	Digital output signals	High	$V_P-.7$		V_P	V
V_{OL}		Low	V_N		$V_N+.7$	V
t_r	Rise time	$C=5\text{pF}$		0.4	0.6	$\mu\text{s/V}$
t_f	Fall time	$C=5\text{pF}$		0.4	0.6	$\mu\text{s/V}$
Differential digital interface (M_CLK1, M_CLK2)						
V_{OH}	Digital output signals, $V(\text{M_CLK1})-V(\text{M_CLK2})$	High		0.3		V
V_{OL}		Low		-0.3		V
VDC_{M_CLK}	M_CLK1,2 Common mode voltage		$V_P-1.65$	$V_P-1.4$	$V_P-1.2$	
t_r	Rise time	$Cl=5\text{pF}$ each pin		10	12	ns
t_f	Fall time	$C=5\text{pF}$		10	12	ns
Z_{out}	Output impedance	balanced		500		Ω
F_{M_CLK1}	M_CLK frequency	Using a 14.72MHz quartz		14.72		MHz
F_{M_CLK2}	M_CLK frequency	Using a 14.725MHz quartz		14.725		MHz

Table 15. Additional optional interface (REF)

Symbol	Parameter	Test conditions/notes	Min.	Typ.	Max.	Unit
P_{REF}	External reference input power	It must be AC coupled to REF, XOSEl low	-2	0		dBm
VDC	REF DC voltage	XOSEl low	$V_P-1.2$	$V_P-1.35$	$V_P-1.6$	V
R_{in}	Input resistance			70		$\text{k}\Omega$

4 Functional description

4.1 Receiver chain

The receiver chain transforms the RF frequency signals to an IF signal at 1.84 MHz carrier directly usable by the channel decoder. In front of the STA011 IC there it must be an external LNA and a band-pass filter; the band-pass filter limits the input bandwidth and guarantees a suitable rejection to the image frequency. The STA011 input stage is a LNA working in the 1452-1492 MHz band. The RF signal is down-converted, using an active mixer, to a first IF of 115.244 MHz. The first LO is tunable with a frequency step of 460 KHz. The RF gain can be reduced by 5dB by using an external trimmer/resistor connected between the PADJ1 and PADJ2 pins, and it can also be reduced by 7.5dB (2.5 step) via the software mode.

A 54 dB typical gain range is guaranteed at IF level. By connecting an external trimmer/resistor to pins GADJ1, GADJ2, the IF output signal level can be decreased to the desired value.

Moreover, the IF chain can be configured to have a fixed gain by fixing statically control voltages on AGC1 and AGC2 pins (i.e. $V(AGC1)=VCC$ and $V(AGC2)=GND$), and trimming the gain by connecting an external resistor between GADJ1 and GADJ2.

By using an 800 Ohm resistor connected between GADJ1 and GADJ2, for example, a typical 56 dBs IF static gain is obtained. The first IF signal, having a bandwidth of 2.5 MHz, shaped by an external SAW filter, is down-converted to a second IF of 1.84 MHz.

A differential clock output of 14.72 MHz is available for use from the base-band.

4.2 Synthesizers, PLL, charge pump and VCOs

The first voltage controlled oscillator is controlled by an integrated PLL, and it's able to cover a frequency range of 37 MHz with a step size of 460 KHz.

The second voltage controlled oscillator produces a fixed 8×117.08 MHz frequency, scaled by a divider by 8, and controlled by a second integrated PLL. Moreover, the 2nd PLL is able to cover the frequency range from 111.76 MHz to 122.4 MHz, suitable for an application test.

The other components of the first PLL synthesizer are a low frequency programmable divider and a dual modulus prescaler; a fixed divider is instead used to synthesize the second VCO frequency. Other internal programmable dividers are used to obtain the comparison frequencies of both loops.

Channel selection is made through the I²C BUS interface, directly from the μP .

4.3 Power supplies

The chip operates from an unregulated power supply of 2.7 to 3.3 Volts. All interface circuits to the base-band chips are operated between these supplies unless otherwise specified.

4.4 Interface specification

All the interface voltage levels to the micro controller are referenced to the supply voltage of the interface power supply (GND). The interface voltage levels are therefore fully compatible with the base-band circuits. The digital levels are all CMOS threshold compatible with the exception of M_CLK1, M_CLK2 pins (ECL type). For a total solution all other interface signals are also included.

5 I²C-bus interface

Data transmission from the microprocessor to the STA011 takes place through the 2 wires (SDA and SCL) of the I²C-bus interface. The STA011 is always a slave device.

5.1 I²C-bus specifications

The I²C-bus protocol defines any device that sends data to the bus as a transmitter, and any device that reads the data as a receiver. The device that controls the data transfer is known as the Master and the others as the slave. The master will always initiate the transfer and will provide the serial clock for synchronization.

5.1.1 Power ON reset

The device at Power ON is able to configure itself to a fixed configuration, with all the circuitry ON and the RFPLL output frequency set to 1356.54MHz (f_{comp}=3.68MHz, N=368.625)

5.1.2 Data validity

Data changes on the SDA line must only occur when the SCL is LOW. SDA transitions while the clock is HIGH are used to identify START or STOP condition.

5.1.3 Start condition

Start is identified by a HIGH to LOW transition of the data bus SDA while the clock signal SCL is stable in the HIGH state. A Start condition must precede any command for data transfer.

5.1.4 Stop condition

A LOW to HIGH transition of the data bus SDA identifies a stop while the clock signal SCL is stable in the HIGH state. A STOP condition terminates communications between the STA011 and the Bus Master.

5.1.5 Byte format

Every byte transferred on the SDA line must contain bits. Each byte must be followed by an acknowledge bit. The MSB is transferred first.

5.1.6 Acknowledge

An acknowledge bit is used to indicate a successful data transfer. The bus transmitter, either master or slave, will release the SDA bus after sending 8 bits of data.

During the 9th clock pulse the receiver pulls the SDA low to acknowledge the receipt of 8 bits of data.

5.1.7 Transmission without acknowledge

To avoid detecting an acknowledge from the STA011, the μ P can use a simpler transmission: simply it waits one clock period without checking the STA011 acknowledging, and sends the new data. This approach of course is less protected from data corruption.

5.1.8 Device addressing

To start the communication between the master and the STA011, the master must initiate with a start condition. Following this, the master sends onto the SDA line 8 bits (MSB first) corresponding to the device select address and read or write mode.

The first 7 MSB's are the device address identifier, corresponding to the I²C-bus definition. For the STA011 these are fixed as 110000A. The A bit is reset to 0 internally by a pull-down resistor but it can be changed through the corresponding external pin Address. In this way if the Address pin is floating the address is fixed to the previous configuration (110000), otherwise if the pin is set high the address is fixed to 1100001.

The 8th bit (LSB) is the read or write operation bit (RW; set to 1 in read mode and to 0 in write mode). After a START condition the STA011 identifies on the Bus the device address and, if matched, it will acknowledge the identification on the SDA bus during the 9th clock pulse.

The following byte after the device identification byte, is the internal sub-address byte that provides access to any of the internal registers.

5.1.9 Write operation (single byte write)

Following a START (S) condition the master sends a device select code with the RW bit set to 0. The I²C gives the acknowledgement and waits for the 1 byte of internal sub address.

This byte provides access to any of the internal registers.

After the reception of the internal byte sub address the I²C again responds with an acknowledgement. The master terminates the transfer by generating a STOP (P) condition.

A single byte write with sub-address 00H would affect DATA_OUT[119:112], so a single byte write with sub-address 02H would affect DATA_OUT[103:96] and so on

A single byte address with sub-address out of ranges 00H - 0FH produces illegal_subaddress signal to go high and DATA_OUT[119:0] will not change until a successive write operation request with the correct range for sub-address will be made.

For example if the sub-address is 15H will be produced illegal_subaddress = '1' and DATA_OUT will no change.

S	110000A	R/W 0	ack	Sub-address byte	ack	DATA IN	ack	P
---	---------	-------	-----	------------------	-----	---------	-----	---

5.1.10 Write operation (multibyte write)

The multi-byte write mode can start from any internal sub address (the same as a single byte write).

Following a START (S) condition the master sends a device select code with the RW bit set to 0. The I²C gives the acknowledgement and waits for 1 byte from the internal sub address.

This byte provides the starting byte of the internal registers.

The master sends the data and each byte isacknowledged by the I²C. The master terminates the transfer by generating a STOP (P) condition.

The sub-address decides the starting byte. A Multi-byte with sub-address 00H and 5 DATA_IN bytes would affect the bytes starting from DATA_OUT [119:112] to DATA_OUT [87:80] and so on. A Multi byte with sub-address from the ranges 00H - 0FH produces illegal sub-address signal to go high, and DATA_OUT[119:0] will not change until a successive write operation request, with the correct range for sub-address will be made.

S	110000A	R/W 0	ack	Sub-address byte	ack	DATA IN	ack	DATA IN	ack	P
---	---------	-------	-----	------------------	-----	---------	-----	-------	---------	-----	---

5.1.11 Read operation

Current byte address read

For the I²C of STA011 this is the only read mode operation implemented. In the current byte address read mode, following a START condition, the master sends the device address with the RW bit set to 1. The I²C acknowledges this and outputs the byte data by reading from the internal byte address counter. The master does not acknowledge the received byte, but terminates the transfer with a STOP condition.

S	110000A	R/W 1	ack	DATA	No ack	P
---	---------	-------	-----	------	--------	---

This method operation is not used.

Data validity

Figure 5. Validity on I²C-bus

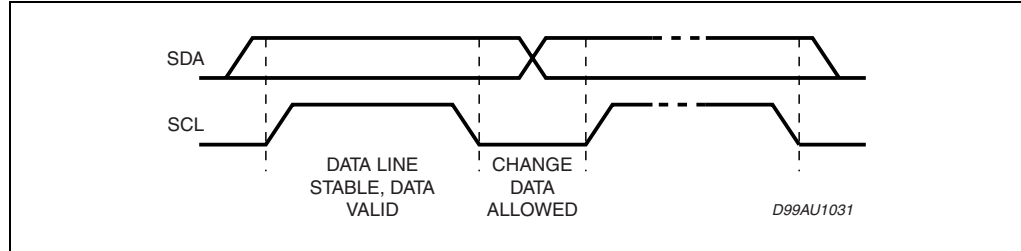

Timing diagram of the I²C-bus:

Figure 6. Timing diagram of the I²C-bus

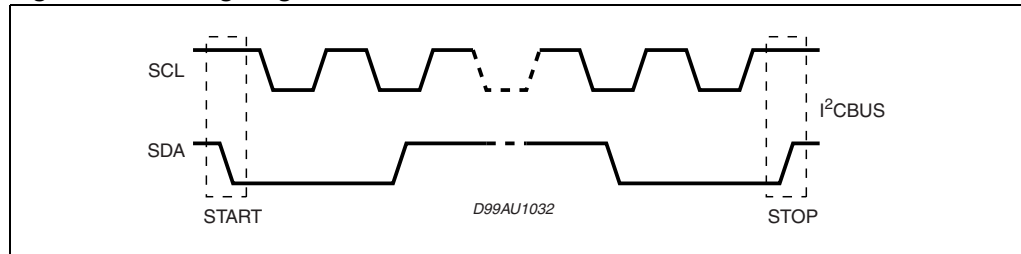

Acknowledge on the I²C-bus:

Figure 7. Ack on I²Cbus

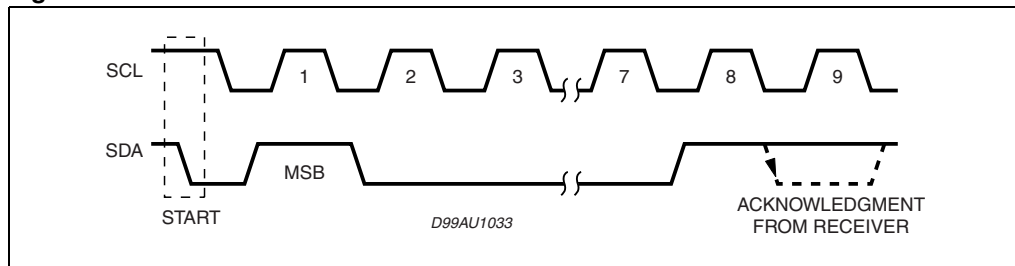

5.1.12 Timing specification

Figure 8. Data and clock

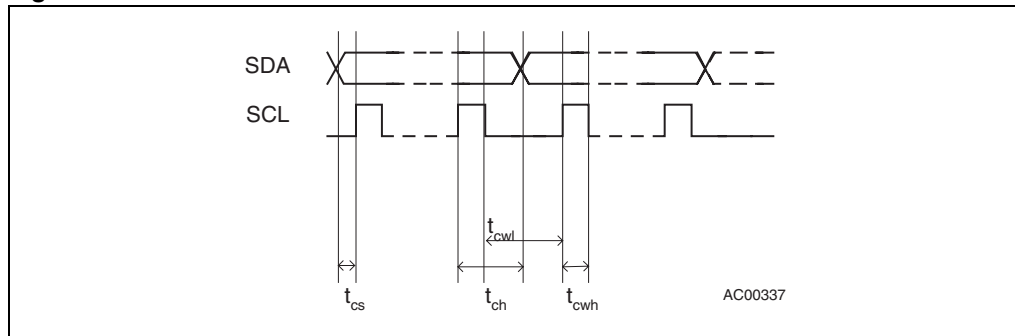

Table 16. Timing electrical characteristics

Symbol	Parameter	Minimum time (ns)
t_{cs}	Data to clock set up time	100
t_{ch}	Data to clock hold time	50
t_{cwh}	Clock pulse width high	100
t_{cwl}	Clock pulse width low	100

5.1.13 Start and stop

Figure 9. Start and stop

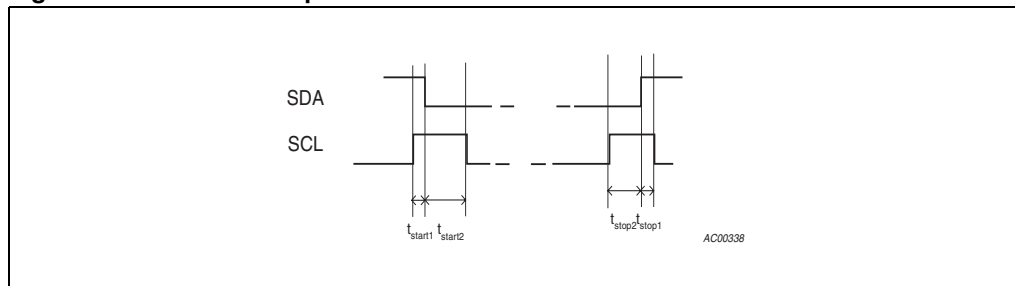

Table 17. Start and stop electrical characteristics

Symbol	Parameter	Minimum time (ns)
$T_{start1,2}$	Clock to data start time	100
$T_{stop1,2}$	Data to clock down stop time	100

5.1.14 ACK

Figure 10. ACK

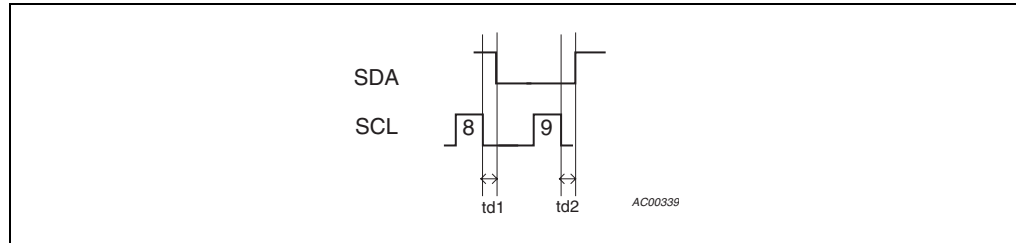

Table 18. ACK electrical characteristics

Symbol	Parameter	Maximum time (ns)
t_{d1}	Ack begin delay	200
t_{d2}	Ack end delay	200

5.2 Software specification

5.2.1 Write mode (multibyte write)

MSB		device address						LSB		MSB		sub-address byte						LSB	
S	1	1	0	0	0	0	A	0	ack	S7	S6	S5	S4	S3	S2	S1	S0	ack	

MSB		1 st data byte					LSB		MSB		2 nd data byte					LSB	
D119	D118	D117	D116	D115	D114	D113	D112	ack	D111	D110	D109	D108	D107	D106	D105	D104	ack

MSB		3 rd data byte					LSB		MSB		4 th data byte					LSB	
D103	D102	D101	D100	D99	D98	D97	D96	ack	D95	D94	D93	D92	D91	D90	D89	D88	ack

MSB		5 th data byte					LSB		MSB		6 th data byte					LSB	
D87	D86	D85	D84	D83	D82	D81	D80	ack	D79	D78	D77	D76	D75	D74	D73	D72	ack

MSB		7 th data byte					LSB		MSB		8 th data byte					LSB	
D71	D70	D69	D68	D67	D66	D65	D64	ack	D63	D62	D61	D60	D59	D58	D57	D56	ack

MSB		9 th data byte					LSB		MSB		10 th data byte					LSB	
D55	D54	D53	D52	D51	D50	D49	D48	ack	D47	D46	D45	D44	D43	D42	D41	D40	ack

MSB		11 th data byte					LSB		MSB		12 th data byte					LSB	
D39	D38	D37	D36	D35	D34	D33	D32	ack	D31	D30	D29	D28	D27	D26	D25	D24	ack

MSB		13 th data byte					LSB		MSB		14 th data byte					LSB	
D23	D22	D21	D20	D19	D18	D17	D16	ack	D15	D14	D13	D12	D11	D10	D9	D8	ack

MSB		13 th data byte					LSB			
D7	D6	D5	D4	D3	D2	D1	D0	ack	P	

ack = Acknowledge

S = Start

P = Stop

Bits description

1st data byte

RFPLL							
Loop divider							
M counter							
D119	D118	D117	D116	D115	D114	D113	D112

2nd data byte

RF PLL							
Loop divider							
Loop divider A counter			K (fractional)				
D111	D110	D109	D108	D107	D106	D105	D104

3rd data byte

RF PLL							
Reference divider					Div 2 Enable	Loop div Enable	CP Enable
Division ratio							
D103	D102	D101	D100	D99	D98	D97	D96

4th data byte

RFPLL							
VCO Enable	ext LO Enable	VCO output voltage setting		Prescaler Enable	Charge Pump current setting		
D95	D94	D93	D92	D91	D90	D89	D88

5th data byte

RF PLL							
Phase frequency detector							
PFD setting					Down ASYM enable	Down Split enable	DAC Enable
D87	D86	D85	D84	D83	D82	D81	D80

Table 19. 6th data byte

RFPLL							
DAC current adjustment					Down Asym delay setting	Not used	
D79	D78	D77	D76	D75	D74	D73	D72

7th data byte

RF path					IFpath		
LNA enable	RF Mixer enable	RF Gain Setting		IF Buffer enable	IF Buffer Current setting	Pre VGA enable	VGA1 enable
D71	D70	D69	D68	D67	D66	D65	D64

8th data byte

IF path			IFPLL				
VGA2 enable	IF Mixer enable	IF2 amp enable	Lock detector setting			VCO Enable	ext LO Enable
D63	D62	D61	D60	D59	D58	D57	D56

9th data byte

IF PLL							
PFD setting					CP enable	Ref div Division ratio	
D55	D54	D53	D52	D51	D50	D49	D48

10th data byte

IF PLL							
Reference divider division ratio							Loop div ratio
D47	D46	D45	D44	D43	D42	D41	D40

11th data byte

IF PLL							
Loop divider Division ratio							
D39	D38	D37	D36	D35	D34	D33	D32

12th data byte

IF PLL		XTAL					
Loop divider division ratio		M_CLK output disable	Double/single ended	Cut-off frequency setting		Loop gain setting	Not used
D31	D30	D29	D28	D27	D26	D25	D24
Not used	Not used	Not used	Not used	Not used
D31	D30

5.3 Read mode

Current byte address read

MSB	chip address						R/W	MSB	data byte								LSB	
S	1	1	0	0	0	0	A	1	ack	B7	B6	B5	B4	B3	B2	B1	B0	P

ack = acknowledge

s = start

p = stop

5.3.1 Bits description

In read mode, only one byte is provided to the master.

PLL's Lock	Not used	Not used	Not used	Not used	Not used	Not used	Not used
B7	B6	B5	B4	B3	B2	B1	B0

The last six not used bits are fixed to 0.

6 Programming specifications

6.1 RFPLL

6.1.1 Loop divider division ratio

M counter								Notes
D119	D118	D117	D116	D115	D114	D113	D112	
...	
0	0	1	0	1	1	1	0	M=46, startup configuration
...	
0	0	1	1	1	0	0	0	
...	

A counter			K (fractional)					Description
D111	D110	D109	D108	D107	D106	D105	D104	$N=M*P+A+K/32$ (P=8)
1	0	1	1	1	0	0	1	
...	
0	0	0	1	0	1	0	0	N=368.625, LO1=368.625x3.68=1356.54 MHz, startup configuration
...	
1	1	0	0	0	1	1	1	
...	
1	0	1	1	1	0	0	1	

6.1.2 Reference divider division ratio

Table 20. Reference divider division ratio

D103	D102	D101	D100	D99	Description	Notes
0	0	0	0	1	R=1	XTAL or TCXO=14.72MHz $f_{comp}=14.72\text{MHz}$,
0	0	0	1	0	R=2	...
...	
0	0	1	0	0	R=4	XTAL=14.72MHz $f_{comp}=3.68\text{MHzKHz}$, startup configuration
...		
0	1	0	0	0	R=8	$f_{comp}=1.84\text{MHz}$
...		
1	0	0	0	0	R=16	$f_{comp}=0.92\text{MHz}$

6.1.3 Blocks enable

Table 21. Blocks enable

	Description	Notes
D98		
0	Divider by 2 OFF	
1	Divider by 2 ON	Startup configuration
D97		
0	Loop Divider OFF	
1	Loop Divider ON	Startup configuration
D96		
0	Charge Pump OFF	
1	Charge Pump ON	Startup configuration
D91		
0	Prescaler OFF	
1	Prescaler ON	Startup configuration

6.1.4 VCO enable

Table 22. VCO enable

D95	D94	Description	Notes
1	0	Internal RFVCO	Startup configuration
1	1	External RFLO	

The internal RFVCO can also be enabled via hardware mode through the ENRFOSC pin.

With the ENRFOSC pin high the software mode is disabled and the RFVCO is turned ON; with the ENRFOSC pin low the software mode is enabled, depending on the truth table described above .

6.1.5 VCO output voltage

Table 23. VCO output voltage

D93	D92	Description	Notes
0	0	Vout=1Vpp	Startup configuration
0	1	Vout=2Vpp	
1	0	Vout=3Vpp	
1	1	Vout=4Vpp	

6.1.6 Charge pump current setting

Table 24. Charge pump current

D90	D89	D88	Description	Notes
0	0	0	$I_{CP}=300\mu A$	
...	
0	1	1	$I_{CP}=400\mu A$	Startup configuration
.			
1	1	1	$I_{CP}=600\mu A$	

6.1.7 PFD programming

Table 25. Frequency phase detector setting

D87	D86	D85	D84	D83	Description	Notes
x	x	1	x	1	Normal operation	Default configuration
x	x	1	0	0	Reference divider test, available @ Lock	Synthesizer test reserved configuration
x	x	1	1	0	Loop divider test available @ Lock	Synthesizer test reserved configuration
0	0	0	x	x	Charge pump test, high impedance state	Synthesizer test reserved configuration
0	1	0	x	x	Charge pump test, DEC active	Synthesizer test reserved configuration
1	0	0	x	x	Charge pump test, INC active	Synthesizer test reserved configuration
1	1	0	x	x	Charge pump test, DEC&INC active	Synthesizer test reserved configuration
D82					Down ASYM	
0					UP and DOWN sym	Startup configuration
1					UP and DOWN asym	
D81						
0					Down Split disabled	
1					Down Split enabled	Startup configuration

6.1.8 Fractional spurious compensation

Table 26. Fractional spurious compensation

D80	Description	Notes
0	DAC OFF	
1	DAC ON	Startup configuration

Table 27. DAC current adjustment

D79	D78	D77	D76	D75	Description	Notes
0	0	1	1	1	N=7	startup configuration

Table 28. Down Asym delay setting

D74	D73	Description	Notes
0	0	Minimum delay	Startup configuration
..	..		
1	1	Maximum delay	

6.2 RF path

6.2.1 Blocks enable

Table 29. Blocks enable

	Description	Notes
D71		
0	LNA OFF	
1	LNA ON	Startup configuration
D70		
0	Mixer OFF	
1	Mixer ON	Startup configuration
D67		
0	Buffer OFF	
1	Buffer ON	Startup configuration

6.2.2 RF gain setting

Table 30. RF gain setting

D69	D68	Description	Notes
1	1	High Gain	
1	0	Medium1	Startup configuration
0	1	Medium2	
0	0	Low Gain	

6.2.3 IF buffer setting

Table 31. IF Buffer setting

D66	Description	Notes
0	Itail=3mA	lower output linearity
1	Itail=4mA	Higher output linearity, startup configuration

6.3 IF path

6.3.1 Blocks disable

Table 32. Blocks disable

D65	Description	Notes
D65		
0	preVGA OFF	
1	preVGA ON	Startup configuration
D64		
0	VGA1 OFF	
1	VGA1 ON	Startup configuration
D63		
0	VGA2 OFF	
1	VGA2 ON	Startup configuration
D62		
0	Mixer OFF	
1	Mixer ON	Startup configuration
D61		
0	IF2Amp OFF	
1	IF2Amp ON	Startup configuration

6.4 Lock detector setting

Table 33. Lock detector setting

D60	D59	D58	Description	Notes
0	0	0	Lock test on RF PLL	Test condition
0	0	1	Lock test on IF PLL	Test condition
1	0	0	Lock test on RF PLL and IF PLL	Startup configuration
x	1	0	Test on RF PLL dividers	Test condition
x	1	1	Test on IF PLL dividers	Test condition

6.5 IF PLL

6.5.1 IFVCO enable

Table 34. IFVCO enable

D57	D56	Description	Notes
1	0	Internal IFVCO	Startup configuration
1	1	External IFLO	Test condition

6.5.2 PFD programming

Table 35. Frequency phase detector setting

D55	D54	D53	D52	D51	Description	Notes
x	x	1	x	1	Normal operation	Default configuration
x	x	1	0	0	Reference divider test, available @ Lock	Synthesizer test reserved configuration
x	x	1	1	0	Loop divider test available @ Lock	Synthesizer test reserved configuration
0	0	0	x	x	Charge pump test, high impedance state	Synthesizer test reserved configuration
0	1	0	x	x	Charge pump test, DEC active	Synthesizer test reserved configuration
1	0	0	x	x	Charge pump test, INC active	Synthesizer test reserved configuration
1	1	0	x	x	Charge pump test, DEC&INC active	Synthesizer test reserved configuration

6.5.3 Charge pump enable

Table 36. Charge pump enable

D50	Description	Notes
0	Charge Pump OFF	
1	Charge Pump ON	Startup configuration

6.5.4 Reference divider division ratio

Table 37. Reference divider division ratio

D49	D48	D47	D46	D45	D44	D43	D42	D41	Description	Notes
0	1	0	0	0	0	0	1	0	R=130	$f_{comp}=113.23\text{KHz}$ startup configuration

6.5.5 Loop divider division ratio

Table 38. Loop divider division ratio

D40	D39	D38	D37	D36	D35	D34	D33	D32	D31	D30	Description	Notes
...		
0	1	1	1	1	0	1	1	0	1	1	N=987	
...		
1	0	0	0	0	0	0	1	0	1	0	N=1034	Startup configuration
...		
1	0	0	0	0	1	1	1	0	0	1	N=1081	
...		

6.6 XTAL

Table 39. XTAL

		Description	Notes
D29			
	0	M_CLK output buffer ON	Startup configuration
	1	M_CLK output buffer OFF	
D28			
	0	M_CLK double ended output	Startup configuration
	1	M_CLK single ended output	
Cut-off frequency setting			
D27	D26		
0	0	Maximum cut-off frequency	
0	1	Intermediate 1	
1	0	Intermediate 2	Startup configuration
1	1	Minimum cut-off frequency	
D25			
	0	open loop gain set low	
	1	open loop gain set high	Startup configuration

6.7 Startup configuration

Table 40. Startup configuration

Data Byte	Binary	Dec Value
1	00101110	46
2	00010100	20
3	00100111	39
4	10001011	139
5	00101011	43
6	00111000	80
7	11101111	239
8	11110010	242
9	00101101	45
10	00000101	5
11	00000010	2
12	10001010	140

7 Evaluation board

Figure 11. Evaluation board schematic

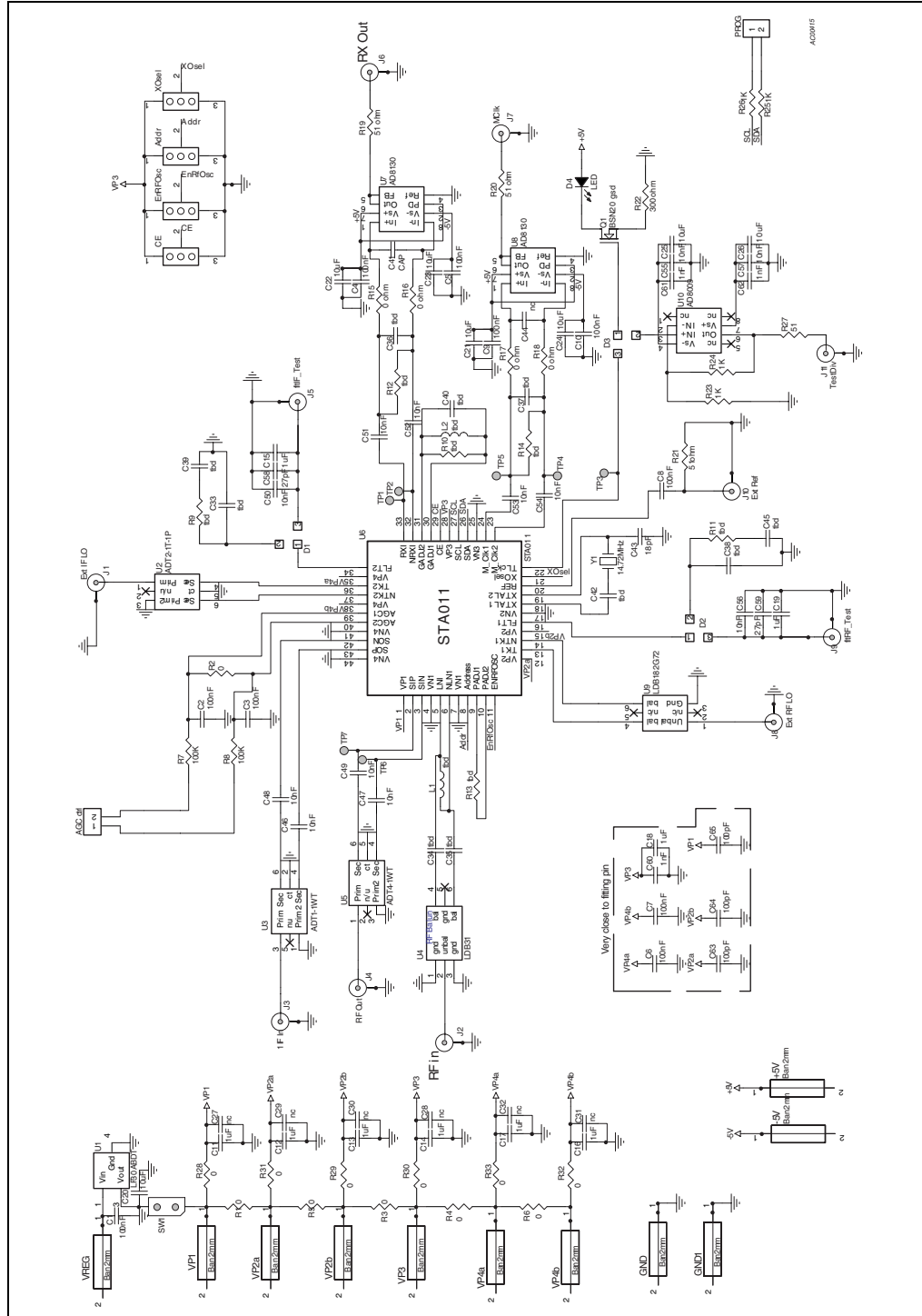

8 Package information

In order to meet environmental requirements, ST (also) offers these devices in ECOPACK® packages. ECOPACK® packages are lead-free. The category of second Level Interconnect is marked on the package and on the inner box label, in compliance with JEDEC Standard JESD97. The maximum ratings related to soldering conditions are also marked on the inner box label.

ECOPACK is an ST trademark. ECOPACK specifications are available at: www.st.com.

Figure 12. TQFP44 mechanical data and package dimensions

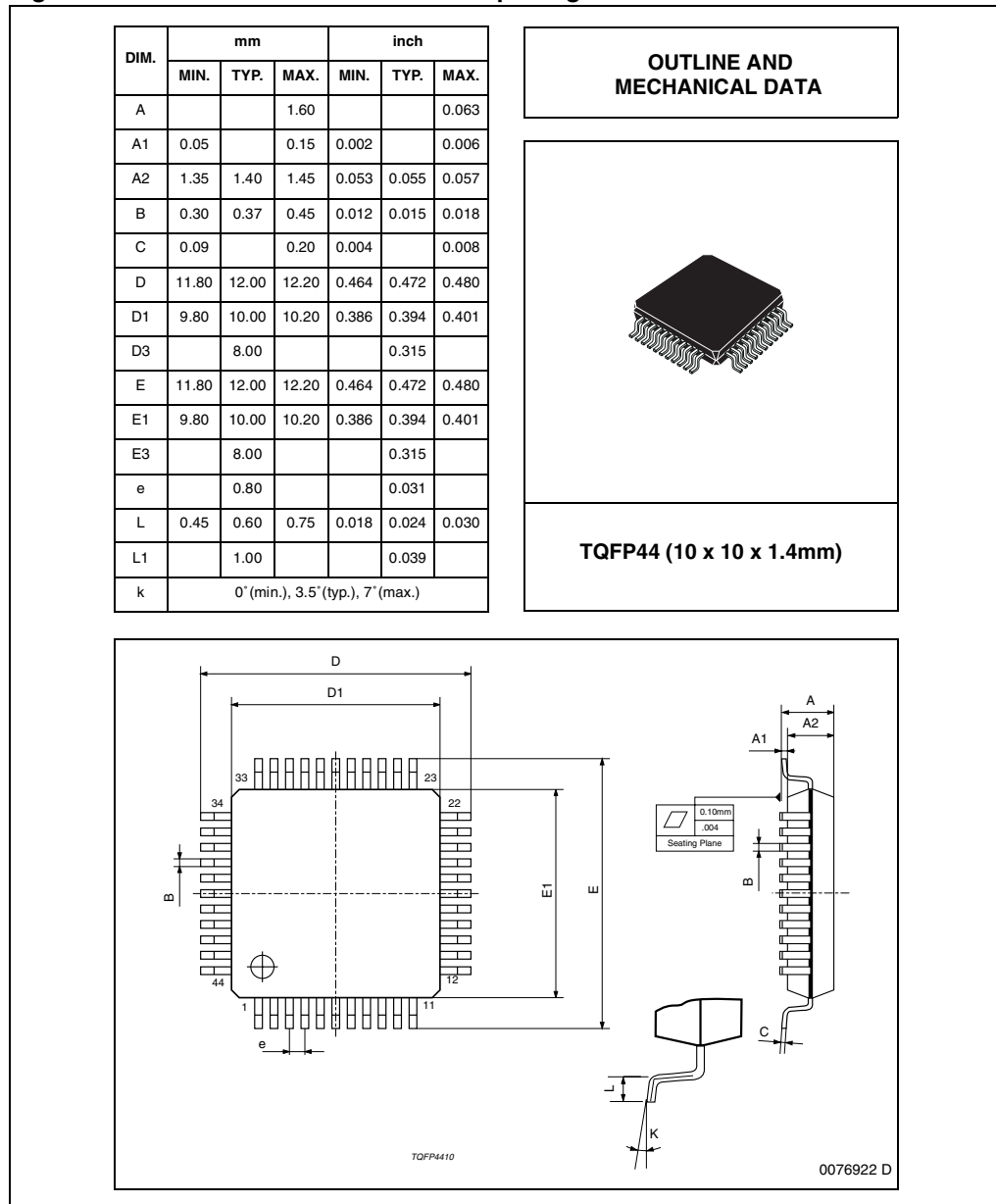

9 Revision history

Table 41. Document revision history

Date	Revision	Changes
21-Nov-2007	1	Initial release.

Please Read Carefully:

Information in this document is provided solely in connection with ST products. STMicroelectronics NV and its subsidiaries ("ST") reserve the right to make changes, corrections, modifications or improvements, to this document, and the products and services described herein at any time, without notice.

All ST products are sold pursuant to ST's terms and conditions of sale.

Purchasers are solely responsible for the choice, selection and use of the ST products and services described herein, and ST assumes no liability whatsoever relating to the choice, selection or use of the ST products and services described herein.

No license, express or implied, by estoppel or otherwise, to any intellectual property rights is granted under this document. If any part of this document refers to any third party products or services it shall not be deemed a license grant by ST for the use of such third party products or services, or any intellectual property contained therein or considered as a warranty covering the use in any manner whatsoever of such third party products or services or any intellectual property contained therein.

UNLESS OTHERWISE SET FORTH IN ST'S TERMS AND CONDITIONS OF SALE ST DISCLAIMS ANY EXPRESS OR IMPLIED WARRANTY WITH RESPECT TO THE USE AND/OR SALE OF ST PRODUCTS INCLUDING WITHOUT LIMITATION IMPLIED WARRANTIES OF MERCHANTABILITY, FITNESS FOR A PARTICULAR PURPOSE (AND THEIR EQUIVALENTS UNDER THE LAWS OF ANY JURISDICTION), OR INFRINGEMENT OF ANY PATENT, COPYRIGHT OR OTHER INTELLECTUAL PROPERTY RIGHT.

UNLESS EXPRESSLY APPROVED IN WRITING BY AN AUTHORIZED ST REPRESENTATIVE, ST PRODUCTS ARE NOT RECOMMENDED, AUTHORIZED OR WARRANTED FOR USE IN MILITARY, AIR CRAFT, SPACE, LIFE SAVING, OR LIFE SUSTAINING APPLICATIONS, NOR IN PRODUCTS OR SYSTEMS WHERE FAILURE OR MALFUNCTION MAY RESULT IN PERSONAL INJURY, DEATH, OR SEVERE PROPERTY OR ENVIRONMENTAL DAMAGE. ST PRODUCTS WHICH ARE NOT SPECIFIED AS "AUTOMOTIVE GRADE" MAY ONLY BE USED IN AUTOMOTIVE APPLICATIONS AT USER'S OWN RISK.

Resale of ST products with provisions different from the statements and/or technical features set forth in this document shall immediately void any warranty granted by ST for the ST product or service described herein and shall not create or extend in any manner whatsoever, any liability of ST.

ST and the ST logo are trademarks or registered trademarks of ST in various countries.

Information in this document supersedes and replaces all information previously supplied.

The ST logo is a registered trademark of STMicroelectronics. All other names are the property of their respective owners.

© 2007 STMicroelectronics - All rights reserved

STMicroelectronics group of companies

Australia - Belgium - Brazil - Canada - China - Czech Republic - Finland - France - Germany - Hong Kong - India - Israel - Italy - Japan - Malaysia - Malta - Morocco - Singapore - Spain - Sweden - Switzerland - United Kingdom - United States of America

www.st.com