

Product Specification

Single Mode 1300 nm 1.0625 Gbit/s Fibre Channel 1.3 Gigabit Ethernet 1x9 Transceiver

V23826-K15-Cxx
V23826-K15-Cxxx

PRODUCT FEATURES

- Compliant with Fibre Channel and Gigabit Ethernet standard
- Meets mezzanine standard height of 9.8 mm
- Compact integrated transceiver unit with
 - MQW laser diode transmitter
 - InGaAs PIN photodiode receiver
 - Duplex SC receptacle
- Class 1 FDA and IEC laser safety compliant
- FDA Accession No. 9520890-19
- Single power supply (5 V or 3.3 V)
- Signal detect indicator (PECL and TTL version)
- PECL differential inputs and outputs
- Process plug included
- Input Signal Monitor (DC/DC-Version)
- Wave solderable and washable with process plug inserted
- For distances of up to 10 km on single mode fiber, and up to 550 m on multimode fiber (use offset jumper as specified in IEEE 802.3)



File: 1167

APPLICATIONS

- 1.25 Gbit/s 1000 Base-LX10 Ethernet
- 1.063 Gbit/s 100-SM-LC-L Fibre Channel

For **PRODUCT SELECTION** see next page.

PRODUCT SELECTION

Part Number	Voltage	Signal Detect	Input	Output
V23826-K15-C313	3.3 V	PECL	AC	DC
V23826-K15-C53	5 V	TTL	AC	AC
V23826-K15-C353	3.3 V			
V23826-K15-C63 ¹⁾	5 V	PECL	DC	DC
V23826-K15-C363 ¹⁾	3.3 V			
V23826-K15-C73	5 V	PECL	AC	AC
V23826-K15-C373	3.3 V			
Add Suffix to P/N	Shield Options			
-C3	Metallized cover, forward springs			
-D3	Metallized cover, backward springs			

Notes:

1) Standard version.

Pin Configuration

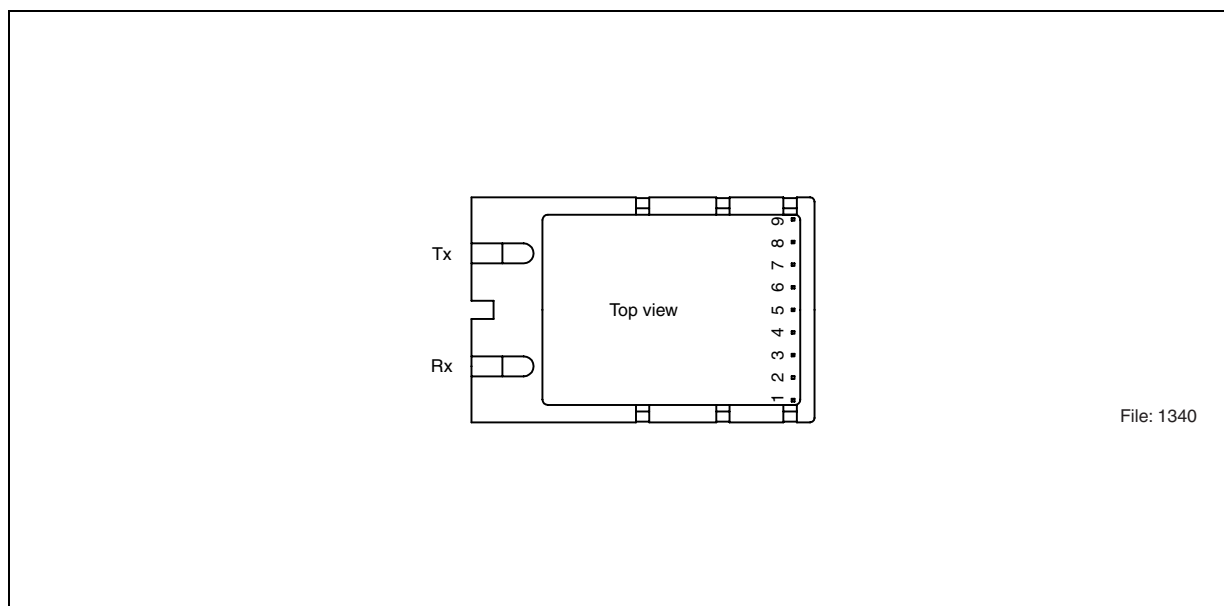

Figure 1

Pin Description

Pin No.	Symbol	Level/Logic	Function	Description
1	$V_{EE}Rx$	Power Supply	Rx Ground	Negative power supply, normally ground
2	RD+	PECL Output	Rx Output Data	Receiver output data
3	RD-			Inverted receiver output data
4	SD	PECL Output active high (TTL C53/353)	Rx Signal Detect	High level on this output shows there is an optical signal
5	$V_{CC}Rx$	Power Supply	Rx 3.3 V/5 V	Positive power supply, 3.3 V/5 V
6	$V_{CC}Tx$		Tx 3.3 V/5 V	
7	TD-	PECL Input	Tx Input Data	Inverted transmitter input data
8	TD+			Transmitter input data
9	$V_{EE}Tx$	Power Supply	Tx Ground	Negative power supply, normally ground
S1/ S2		Mech. Support	Stud Pin	Not connected

Description

The Finisar single mode transceiver is based on and compliant to the Physical Medium Depend (PMD) sublayer and baseband medium, type 1000 Base-LX (long wavelength) as specified in IEEE 802.3 and Fibre Channel FC-PI Rev. 13 100-SM-LC-L.

The appropriate fiber optic cable is 9 μm (mode field diameter) single mode fiber (up to 10 km) with Duplex SC connector.

The Finisar single mode transceiver is a single unit comprised of a transmitter, a receiver, and an SC receptacle. This design frees the customer from many alignment and PC board layout concerns. The module is designed for low cost LAN, WAN and Gigabit Ethernet applications. It can be used as the network end device interface in mainframes, workstations, servers, and storage devices, and in a broad range of network devices such as bridges, routers, intelligent hubs, and local and wide area switches.

This transceiver operates at 1.0625 and 1.3 Gbit/s from a single power supply (+5 V or 3.3 V). The full differential data inputs and outputs are PECL compatible.

Functional Description

This transceiver is designed to transmit serial data via single mode or multimode cable.

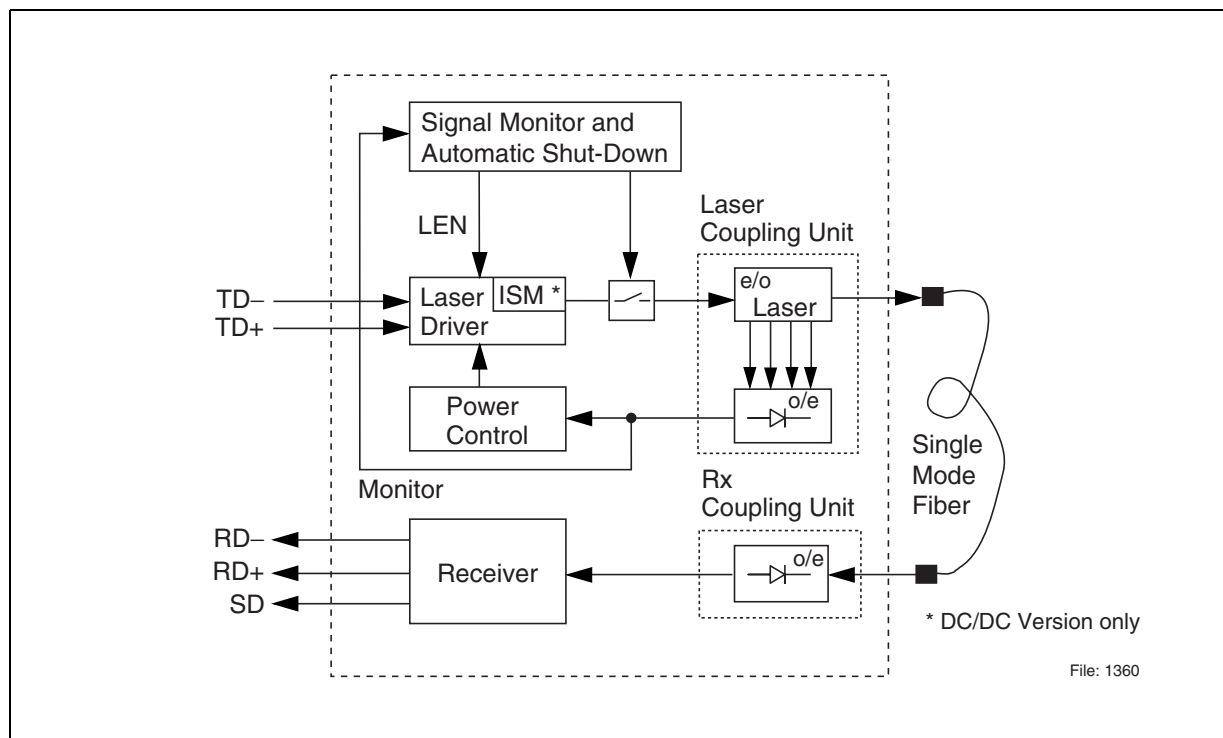

Figure 2 Functional Diagram

The receiver component converts the optical serial data into PECL compatible electrical data (RD+ and RD-). The Signal Detect (SD, active high) shows whether an optical signal is present.

The transmitter converts electrical PECL compatible serial data (TD+ and TD-) into optical serial data.

The following versions are available:

- 1 AC/DC Transceiver: Tx is AC coupled. Differential 100 Ω load. Rx has standard PECL output and is DC coupled.
- 2 AC/AC TTL Transceiver: Tx and Rx are AC coupled. Tx has differential 100 Ω load. Signal Detect is TTL compatible.
- 3 DC/DC Transceiver: Standard PECL inputs and outputs Tx and Rx are DC coupled. This version contains an Input Signal Monitor (ISM) which switches off the transceiver if a continuous low level is applied at Data Input.
- 4 AC/AC PECL Transceiver: Tx and Rx are AC coupled. Tx has differential 100 Ω load. Signal Detect is PECL compatible.

The transmitter contains a laser driver circuit that drives the modulation and bias current of the laser diode. The currents are controlled by a power control circuit to guarantee constant output power of the laser over temperature and aging.

The power control uses the output of the monitor PIN diode (mechanically built into the laser coupling unit) as a controlling signal, to prevent the laser power from exceeding the operating limits.

Single fault condition is ensured by means of an integrated automatic shutdown circuit that disables the laser when it detects transmitter failures. A reset is only possible by turning the power off, and then on again.

The transceiver contains a supervisory circuit to control the power supply. This circuit generates an internal reset signal whenever the supply voltage drops below the reset threshold. It keeps the reset signal active for at least 140 milliseconds after the voltage has risen above the reset threshold. During this time the laser is inactive.

Regulatory Compliance

Feature	Standard	Comments
ESD: Electrostatic Discharge to the Electrical Pins	MIL-STD 883D Method 3015.7 JESD22-A114-B	Class 1 (> 1000 V) HBM Class 1C
Immunity: Electrostatic Discharge (ESD) to the Duplex SC Receptacle	EN 61000-4-2 IEC 61000-4-2	Discharges of ± 15 kV with an air discharge probe on the receptacle cause no damage.
Immunity: Radio Frequency Electromagnetic Field	EN 61000-4-3 IEC 61000-4-3	With a field strength of 3 V/m, noise frequency ranges from 10 MHz to 1 GHz. No effect on transceiver performance between the specification limits.
Emission: Electromagnetic Interference (EMI)	FCC 47 CFR Part 15 Class B EN 55022 Class B CISPR 22	Noise frequency range: 30 MHz to 18 GHz; Margins depend on PCB layout and chassis design.

Technical Data**Absolute Maximum Ratings**

Parameter	Symbol	Limit Values		Unit
		min.	max.	
Package Power Dissipation ¹⁾			1.5	W
Supply Voltage	3.3 V 5 V	$V_{CC}-V_{EE}$	4 6	V
Data Input Levels (PECL)			$V_{CC}+0.5$	V
Differential Data Input Voltage			2.5	V
Operating Ambient Temperature		0	70	°C
Storage Ambient Temperature		-40	85	°C
Soldering Conditions Temp/Time (MIL-STD 883C, Method 2003)			250/5.5	°C/s

Notes:

- 1) For $V_{CC}-V_{EE}$ (min., max.). 50% duty cycle. The supply current does not include the load drive current of the receiver output.

Exceeding any one of these values may destroy the device immediately.

Recommended Operating Conditions

Parameter	Symbol	Values			Unit
		min.	typ.	max.	
Ambient Temperature	T_{AMB}	0		70	°C
Power Supply Voltage	$V_{CC}-V_{EE}$	3.1 4.75	3.3 5	3.5 5.25	V
Supply Current ¹⁾	I_{CC}			230 270	mA
Transmitter					
Data Input High Voltage DC/DC	$V_{IH}-V_{CC}$	-1165		-880	mV
Data Input Low Voltage DC/DC	$V_{IL}-V_{CC}$	-1810		-1475	mV
Data Input Differential Voltage ²⁾ AC/DC, AC/AC TTL, AC/AC PECL	V_{DIFF}	300		800	mV
Input Data Rise/Fall Time 10% - 90%	t_R, t_F	100		750	ps
Receiver					
Input Center Wavelength	λ_C	1270		1355	nm

Notes:

- 1) For $V_{CC}-V_{EE}$ (min., max.) 50% duty cycle. The supply current does not include the load drive current of the receiver output.
- 2) Peak to peak voltage of one input.

The electro-optical characteristics described in the following tables are only valid for use under the recommended operating conditions.

Transmitter Electro-Optical Characteristics

Parameter	Symbol	Values			Unit
		min.	typ.	max.	
Launched Power (Average) ¹⁾	P_O	-11		-3	dBm
Center Wavelength	λ_C	1270		1355	nm
Spectral Width (RMS)	σ_I			4	nm
Relative Intensity Noise	RIN			-120	dB/Hz
Extinction Ratio (Dynamic)	ER	9			dB
Reset Threshold ²⁾	V_{TH}		3.5 2.7		V
Reset Time Out ²⁾	t_{RES}	15	22	35	ms

Notes:

- 1) Into single mode fiber, 9 μ m diameter.
- 2) Laser power is shut down if power supply is below V_{TH} and switched on if power supply is above V_{TH} after t_{RES} .

Receiver Electro-Optical Characteristics

Parameter	Symbol	Values			Unit
		min.	typ.	max.	
Sensitivity (Average Power) ¹⁾	P_{IN}		-22	-20	dBm
Saturation (Average Power)	P_{SAT}			-3	dBm
Signal Detect Assert Level ²⁾	P_{SDA}			-20	dBm
Signal Detect Deassert Level ³⁾	P_{SDD}	-30			dBm
Signal Detect Hysteresis	P_{SDA} $-P_{SDD}$		1.5		dB
Signal Detect Assert Time	t_{ASS}			100	μ s
Signal Detect Deassert Time	t_{DAS}			350	μ s
Output Low Voltage ⁴⁾	$V_{OL}-V_{CC}$	-1950		-1600	mV
Output High Voltage ⁴⁾	$V_{OH}-V_{CC}$	-1025		-720	mV
Signal Detect Output Low Voltage AC/AC TTL ⁵⁾	V_{SDL}			0.5	V
Signal Detect Output High Voltage AC/AC TTL ⁵⁾	V_{SDH}	2			V
Data Output Differential Voltage ⁶⁾	V_{DIFF}	0.5		0.9	V
Output Data Rise/Fall Time, 20% - 80%	t_R, t_F			375	ps
Return Loss of Receiver	ORL	12			dB

Notes:

- 1) Minimum average optical power at which the BER is less than 1×10^{-12} or lower. Measured with a 2^7-1 NRZ PRBS and ER = 9 dB. Output of single mode fiber 9 μ m diameter.
- 2) An increase in optical power above the specified level will cause the Signal Detect output to switch from a low state to a high state.
- 3) A decrease in optical power below the specified level will cause the Signal Detect to change from a high state to a low state.
- 4) DC/DC, AC/DC for data. DC/DC, AC/DC, AC/AC PECL for Signal Detect. PECL compatible. Load is 50 Ω into $V_{CC}-2$ V for data, 500 Ω to V_{EE} for Signal Detect. Measured under DC conditions. For dynamic measurements a tolerance of 50 mV should be added. $V_{CC} = 3.3$ V/5 V. $T_{AMB} = 25^\circ\text{C}$.
- 5) Max. output current high: -0.4 mA (drive current), max. output current low: +2 mA (sink current).
- 6) AC/AC for data. Load 50 Ω to GND or 100 Ω differential. For dynamic measurement a tolerance of 50 mV should be added.

Eye Safety

This laser based single mode transceiver is a Class 1 product. It complies with IEC 60825-1/A2: 2001 and FDA performance standards for laser products (21 CFR 1040.10 and 1040.11) except for deviations pursuant to Laser Notice 50, dated July 26, 2001.

CLASS 1 LASER PRODUCT

To meet laser safety requirements the transceiver shall be operated within the Absolute Maximum Ratings.

Note: All adjustments have been made at the factory prior to shipment of the devices. No maintenance or alteration to the device is required.

Tampering with or modifying the performance of the device will result in voided product warranty.

Failure to adhere to the above restrictions could result in a modification that is considered an act of “manufacturing”, and will require, under law, recertification of the modified product with the U.S. Food and Drug Administration (ref. 21 CFR 1040.10 (i)).

Laser Emission Data

Wavelength	1310 nm
Maximum total output power (as defined by IEC: 7 mm aperture at 14 mm distance)	15.6 mW / 11.9 dBm
Beam divergence (full angle) / NA (half angle)	11° / 0.1 rad

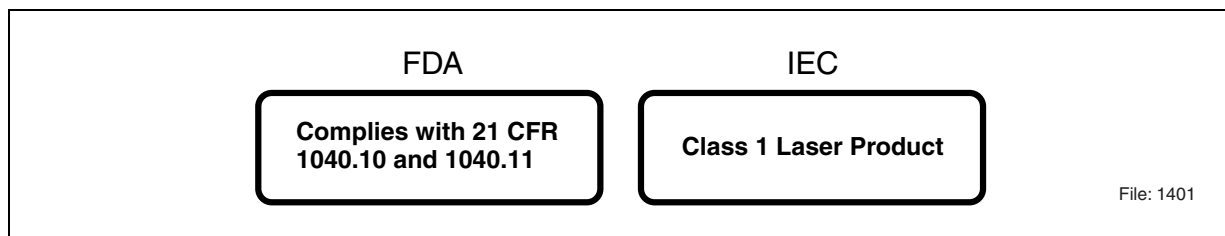

Figure 3 Required Labels

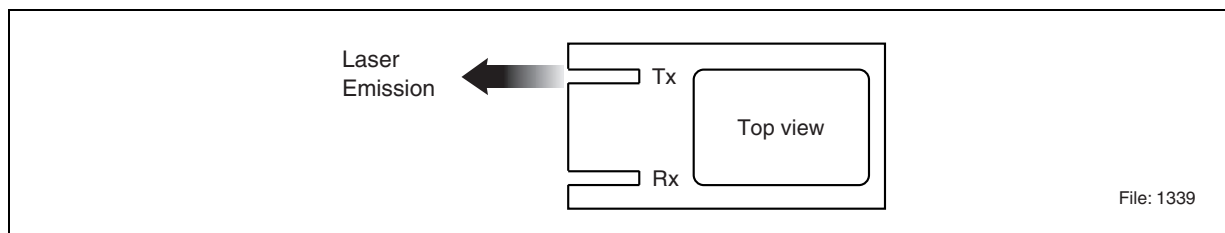

Figure 4 Laser Emission

Application Notes

Gigabit transceivers and matching circuits are high frequency components and shall be terminated as recommended in the application notes for proper EMI performance. Electromagnetic emission may be caused by these components.

To prevent emissions it is recommended that cutouts for the fiber connectors be designed as small as possible.

It is strongly recommended that the Tx plug and the Rx plug be separated with a bar that divides the duplex SC opening.

If shielded parts are employed, they should be in proper contact with the bezel (back plane).

Since the shield is galvanically isolated from signal ground it is strongly recommended to prevent any contact between shield and the circuitry i.e. even any ground connection on the pcb may be harmful to EMI performance.

In cases where EMI performance becomes critical it has proven to be helpful when using SC-plugs with less metal parts inside (as Finisar fibers).

Single Mode 1300 nm Gigabit Ethernet/Fibre Channel 1x9 Transceiver, DC/DC Version

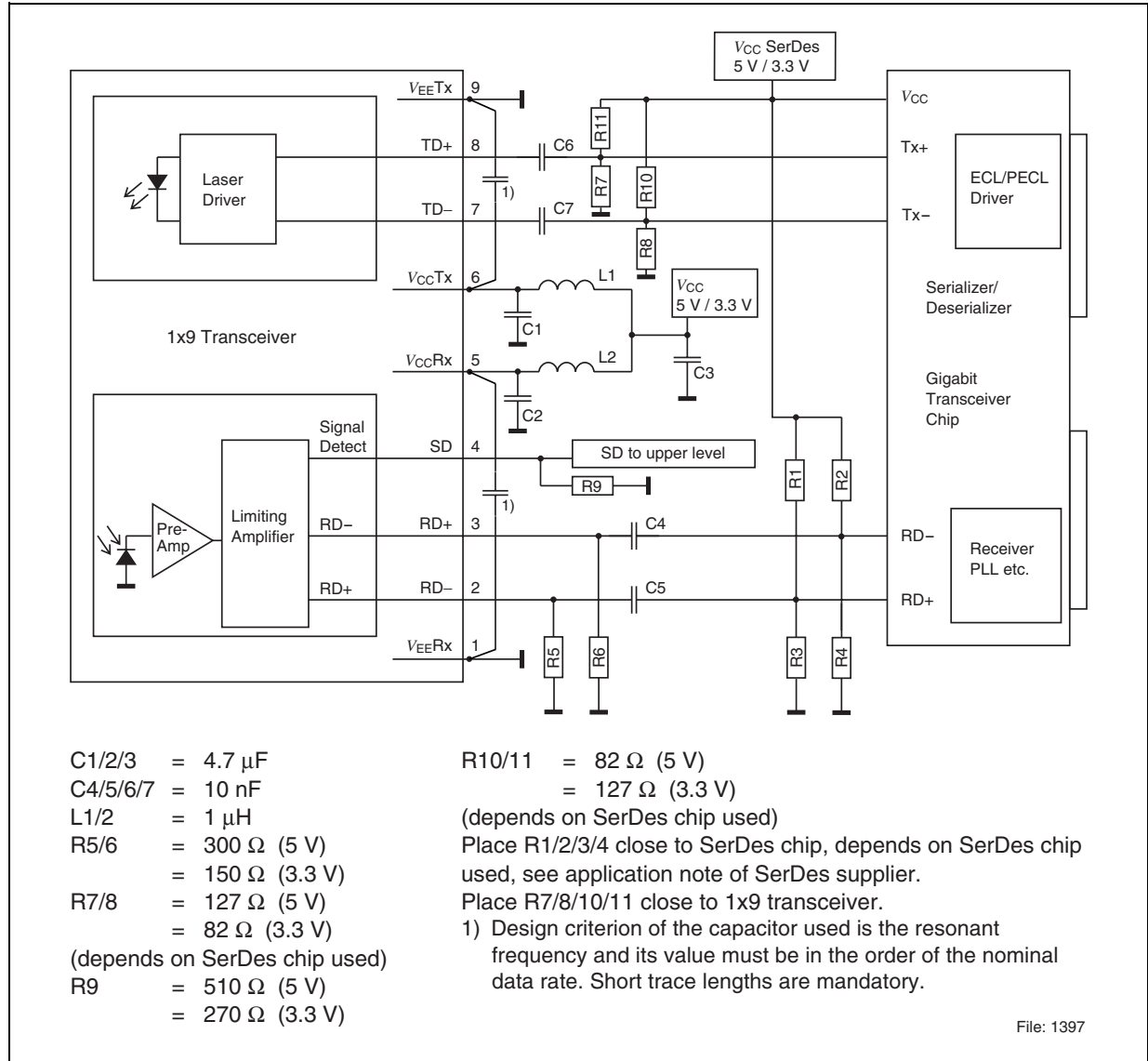

Figure 5

Values of R1/2/3/4 may vary as long as proper 50 Ω termination to V_{EE} or 100 Ω differential is provided. The power supply filtering is required for good EMI performance. Use short tracks from the inductor L1/L2 to the module $V_{CC}Rx/V_{CC}Tx$. We recommend a GND plane under the module for getting good EMI performance.

The transceiver contains an automatic shutdown circuit. Reset is only possible if the power is turned off, and then on again. ($V_{CC}Tx$ switched below V_{TH}).

Application Board available on request.

The stud pins S1 and S2 are not connected.

Single Mode 1300 nm Gigabit Ethernet/Fibre Channel 1x9 Transceiver, AC/DC Version

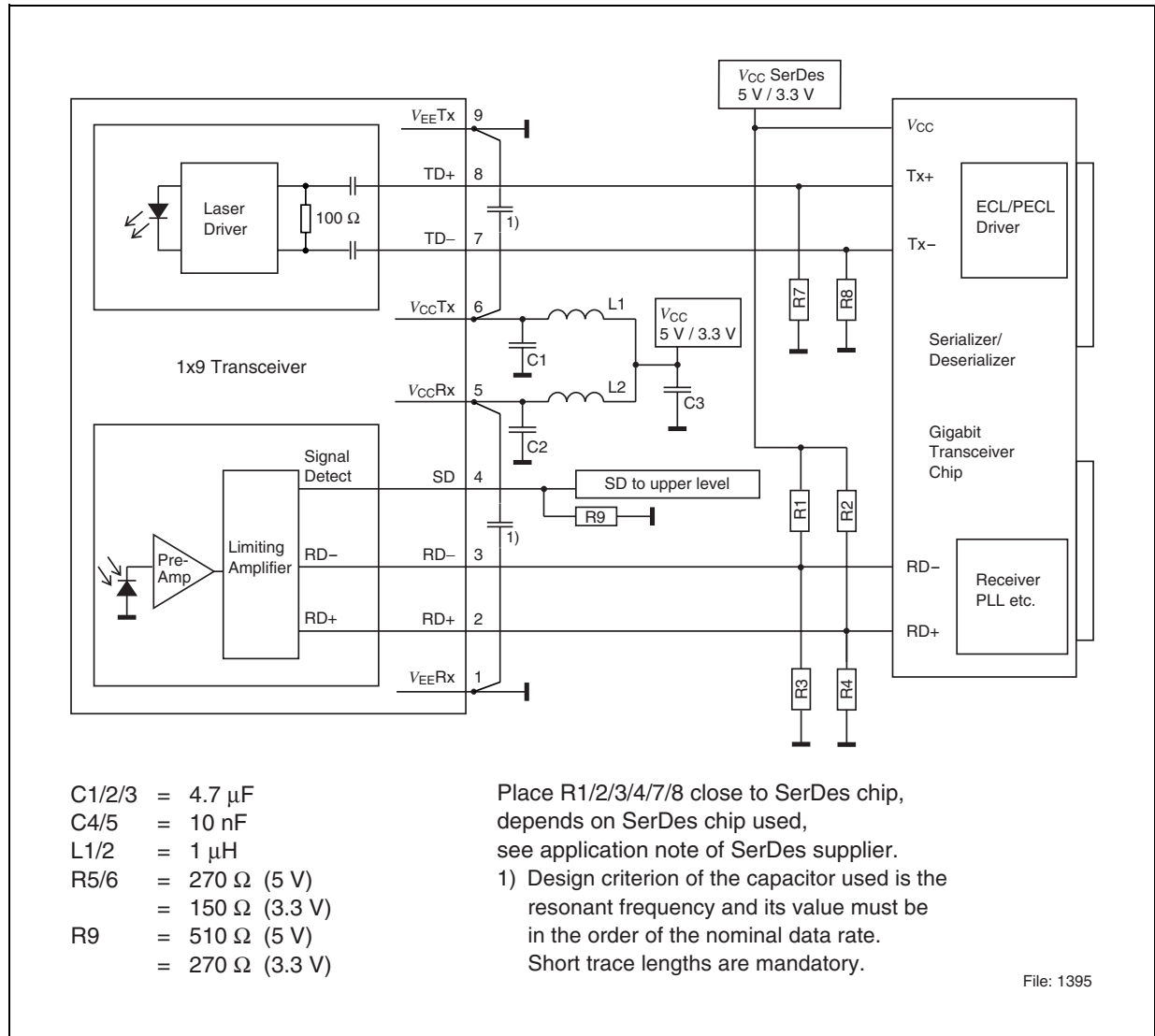

Figure 6

Values of R1/2/3/4 may vary as long as proper 50Ω termination to V_{EE} or 100Ω differential is provided. The power supply filtering is required for good EMI performance. Use short tracks from the inductor L1/L2 to the module $V_{CC}Rx/V_{CC}Tx$. We recommend a GND plane under the module for getting good EMI performance.

The transceiver contains an automatic shutdown circuit. Reset is only possible if the power is turned off, and then on again. ($V_{CC}Tx$ switched below V_{TH}).

Application Board available on request.

The stud pins S1 and S2 are not connected.

Single Mode 1300 nm Gigabit Ethernet/Fibre Channel 1x9 Transceiver, AC/AC TTL and AC/AC PECL Versions

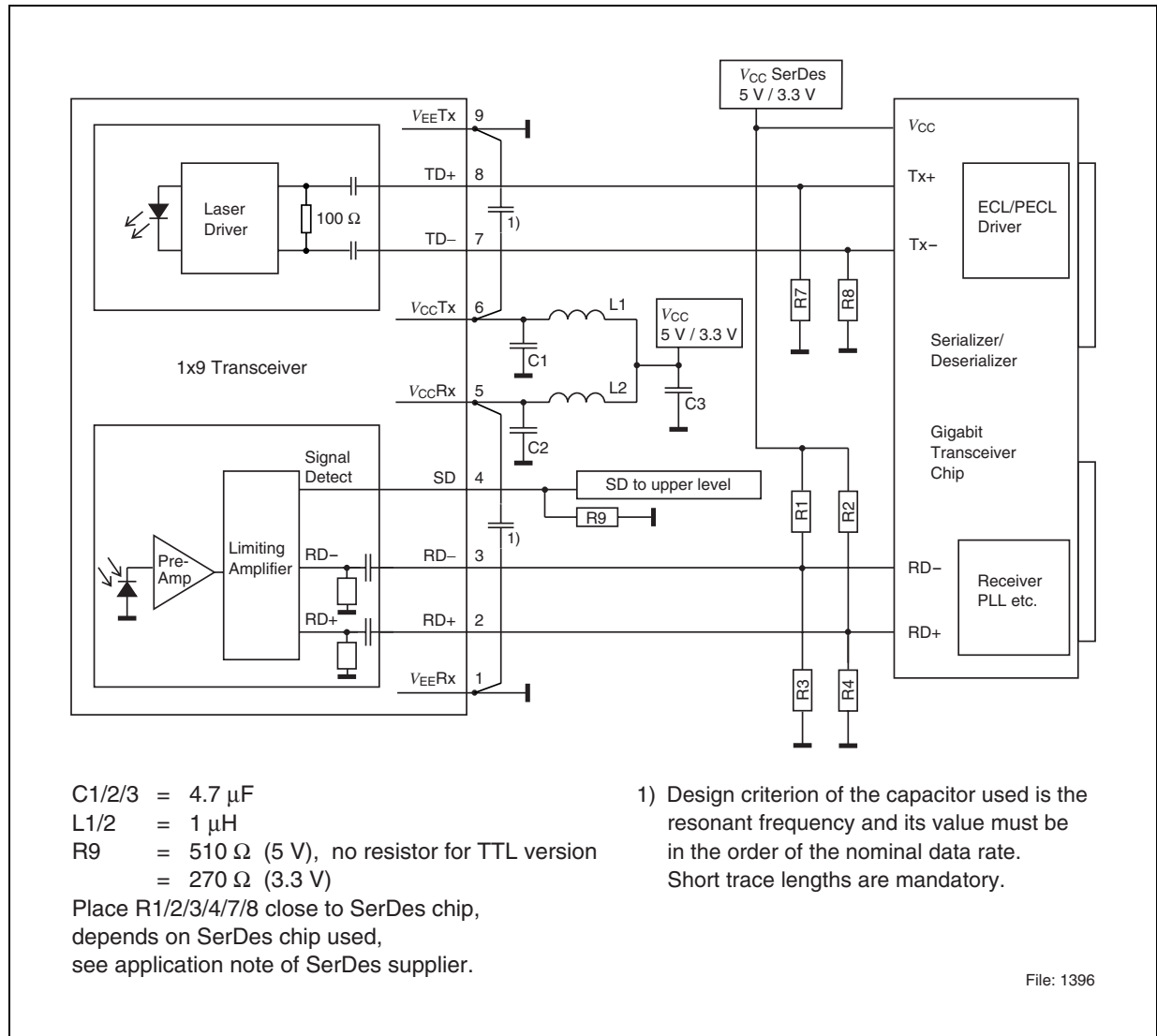

Figure 7

The power supply filtering is required for good EMI performance. Use short tracks from the inductor L1/L2 to the module $V_{CC Rx}/V_{CC Tx}$. We recommend a GND plane under the module for getting good EMI performance.

The transceiver contains an automatic shutdown circuit. Reset is only possible if the power is turned off, and then on again. ($V_{CC Tx}$ switched below V_{TH}).

Application Board available on request.

The stud pins S1 and S2 are not connected.

Shield Options

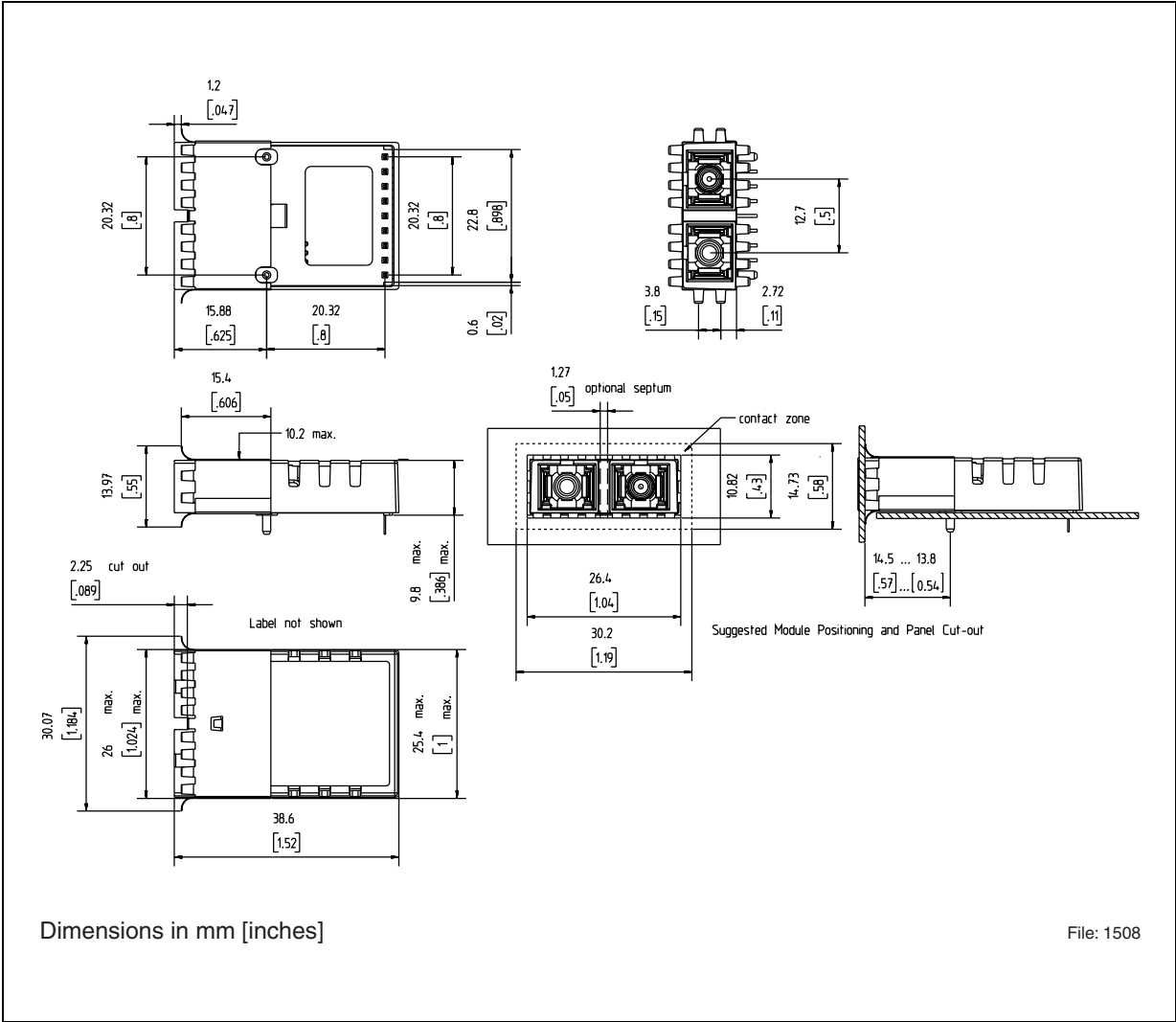

Figure 8 Shield with Forward Springs, -C3

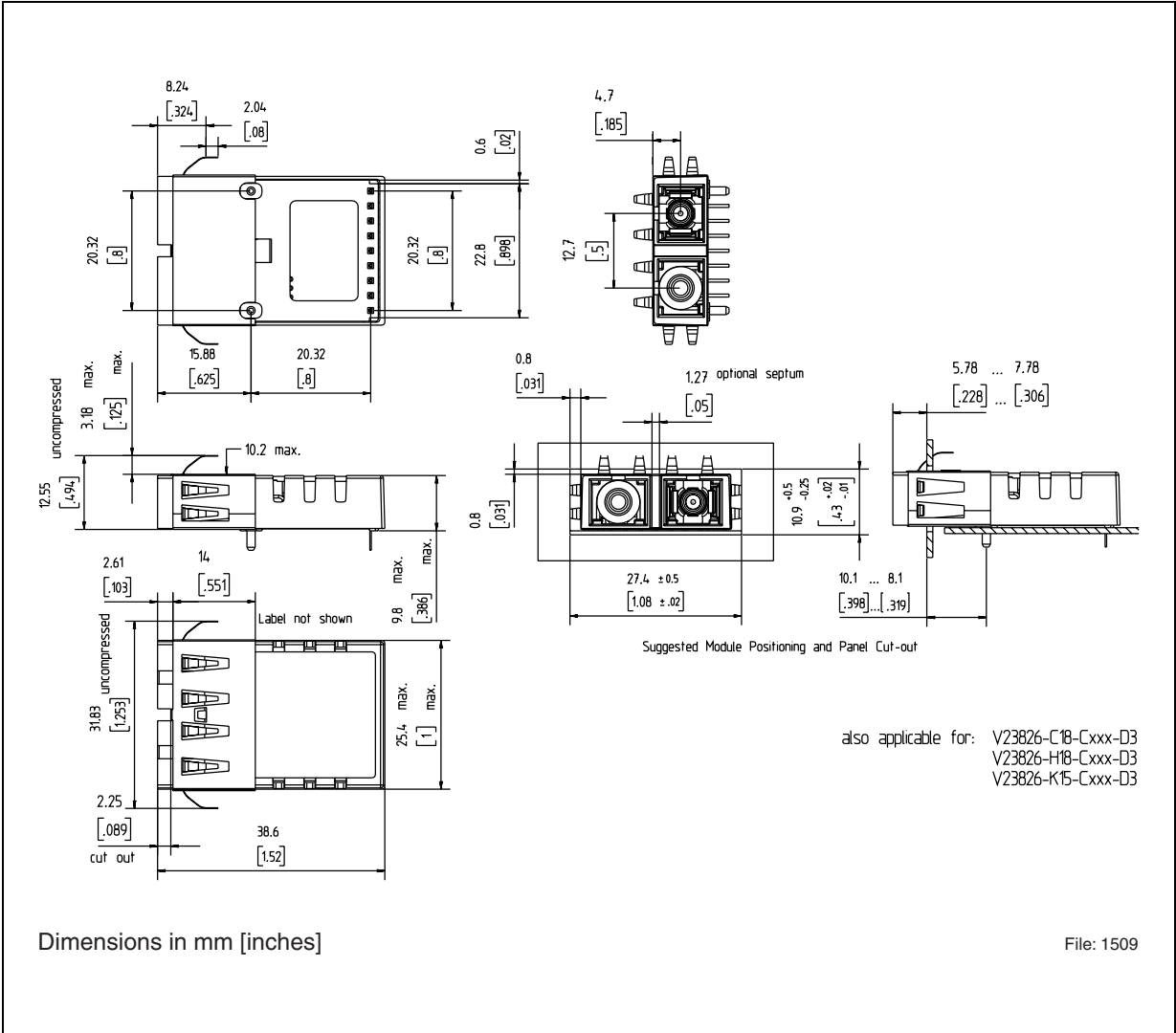

Figure 9 Shield with Backward Springs, -D3

Package Outlines

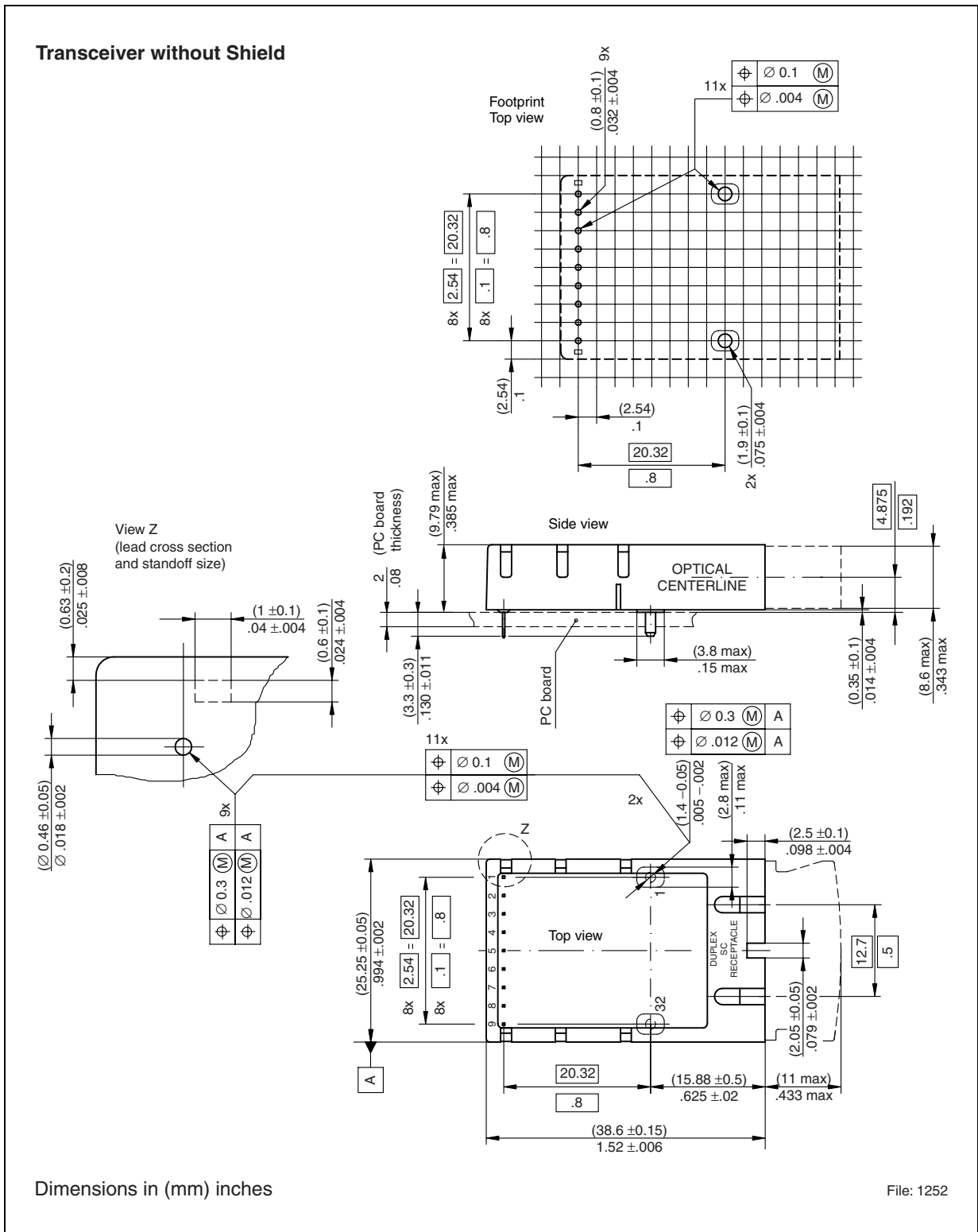

Figure 10

Revision History:	August 27, 2004	Rev. B
Previous Version:	March 09, 2000	
Page	Subjects (major changes since last revision)	
	Company name has been changed Document's layout has been changed December 2004	

For More Information

Finisar Corporation
1308 Moffett Park Drive
Sunnyvale, CA 94089-1133
Tel. 1-408-548-1000
Fax 1-408-541-6138
sales@finisar.com
www.finisar.com