

## ORDERING INFORMATION

Device	Temperature Range	Package
MC1312P	0°C to +70°C	Plastic DIP
MC1314P	0°C to +70°C	Plastic DIP
MC1315P	0°C to +70°C	Plastic DIP

### CBS SQ\* LOGIC DECODER SYSTEM

The CBS SQ\* matrix system designed to decode SQ encoded program material into four separate channels. This system conforms to specifications for decoding quadraphonic records produced by the largest record companies in the world.

#### MC1312P - DECODER

The MC1312P consists of two high input impedance preamplifiers which are fed with left total,  $L_T$ , and right total,  $R_T$ , signals. The preamplifiers each feed two all-phase networks which generate two  $L_T$  signals in quadrature and two  $R_T$  signals in quadrature. The four signals are matrixed to yield left front, left back, right front, and right back signals ( $L_F'$ ,  $L_B'$ ,  $R_F'$ ,  $R_B'$ ).

#### MC1314P - VOLTAGE CONTROLLED ATTENUATOR

The MC1314P is a gain control and balance adjustment unit for use with any quadraphonic system. It has four channels whose gain can be varied by an external dc voltage. In addition, the relative gain between channels can be set by 3 external dc voltages. Thus with four variable resistors the master volume  $L_F/R_F$ ,  $L_B/R_B$  and F/B balance may be controlled.

#### MC1315P - LOGIC CIRCUIT

The MC1315P provides the basic logic function to enhance the front to back separation in the CBS SQ four channel decoding system. This device is designed to interface with the MC1312 decoder and MC1314. The MC1315P provides dc logic enhancement control signals which extends the performance of the basic SQ system to the levels desired for top-of-the-line systems.

FIGURE 1 - SQ LOGIC DECODER SYSTEM

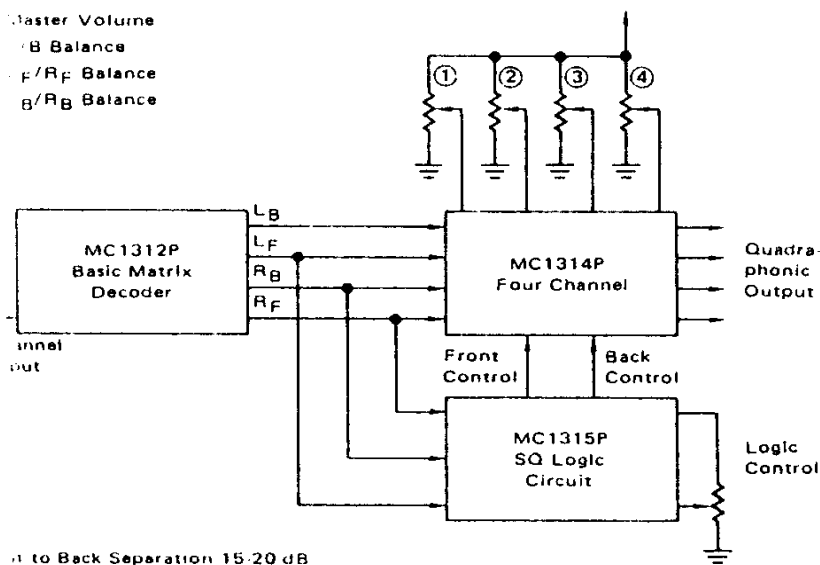

© 1977, CBS Inc.

# MC1312P MC1314P MC1315P

## FOUR CHANNEL SQ LOGIC DECODER SYSTEM

SILICON MONOLITHIC INTEGRATED CIRCUIT

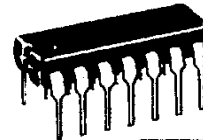

P SUFFIX  
PLASTIC PACKAGE  
CASE 646

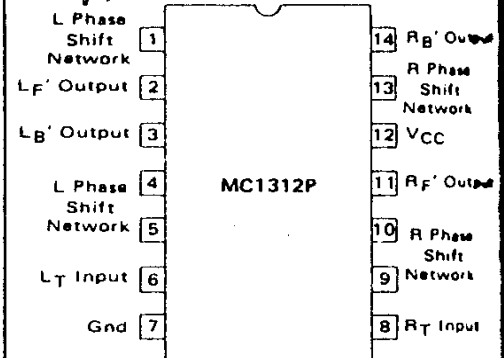

P SUFFIX  
PLASTIC PACKAGE  
CASE 648

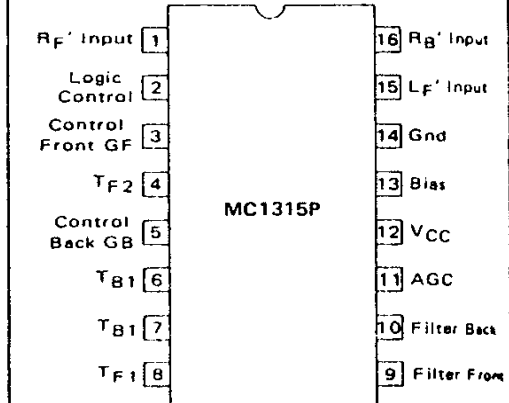
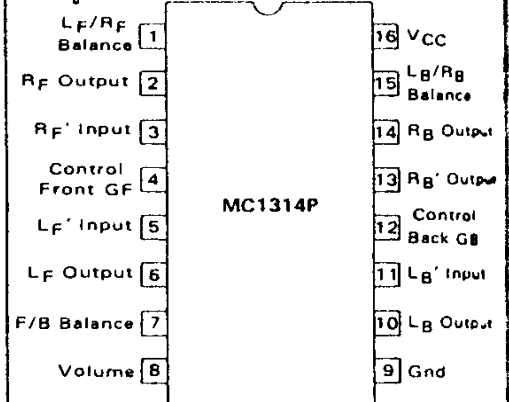

This component is sold without patent indemnity and any infringement resulting from use or resale thereof shall be the sole responsibility of purchaser and shall not be the responsibility of Intel Corporation.

MAXIMUM RATINGS ( $T_A = +25^{\circ}\text{C}$  unless otherwise noted.)

Rating	Value	Unit
Power Supply Voltage	25	Vdc
Power Dissipation @ $T_A = 25^{\circ}\text{C}$ Derate above $+25^{\circ}\text{C}$	750 6.7	mW mW/ $^{\circ}\text{C}$
Operating Temperature Range	0 to +70	$^{\circ}\text{C}$
Storage Temperature Range	-65 to +150	$^{\circ}\text{C}$

ELECTRICAL CHARACTERISTICS ( $V_{CC} = +20\text{ Vdc}$ ,  $V_{in} = 0.5\text{ V(RMS)}$  @ 1 kHz,  $T_A = +25^{\circ}\text{C}$  unless otherwise noted.)

Characteristic	Min	Typ	Max	Unit
Supply Current Drain	11	16	21	mA
Input Impedance	1.8	3.0	—	$\text{M}\Omega$
Output Impedance	—	5.0	—	$\text{k}\Omega$
Channel Balance ( $L_F/R_F$ )	-1.0	0	+1.0	dB
Relative Voltage Gain $L_B'/L_F'$ , $R_B'/L_F'$ , $L_B'/R_F'$ , $R_B'/R_F'$ $L_F'$ measurements made with $L_T$ input, $R_F'$ measurements made with $R_T$ input.	-2.0	-3.0	-4.0	dB
Maximum Input Voltage for 1%THD at Output $R_T$ or $L_T$	2.0	—	—	V(RMS)
Total Harmonic Distortion $R_T$ or $L_T$	—	0.1	—	%
Signal to Noise Ratio (Short-Circuit Input $V_O = 0.5\text{ V(RMS)}$ with Output Noise Referenced to Output Voltage, $V_O$ ) (BW = 20 Hz to 20 kHz)	—	80	—	dB

FIGURE 2 - MC1312P TEST CIRCUIT

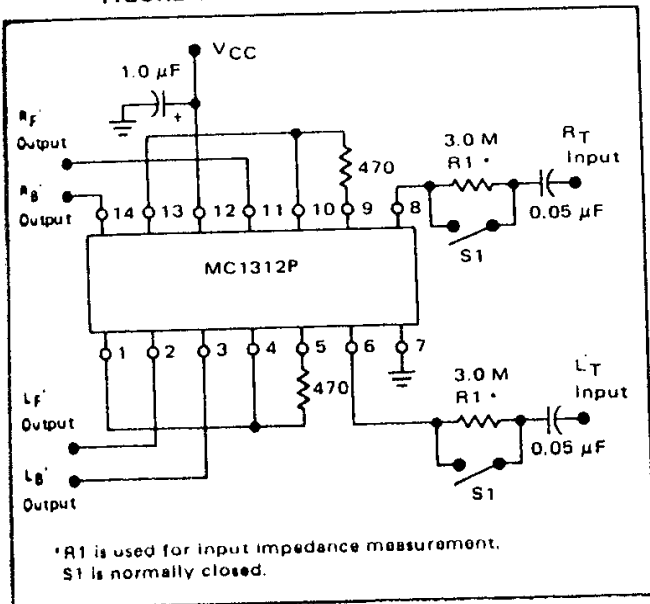
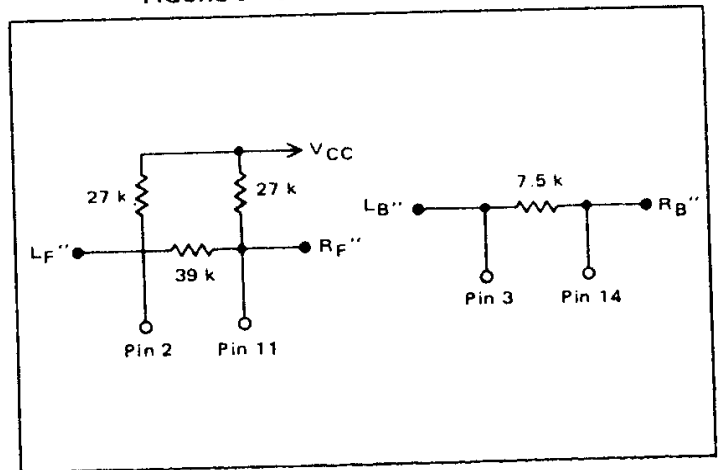

FIGURE 3 - EIA STANDARD BLEND



Note: In applications where tone arm pick-up is connected directly to the MC1312P inputs, a 300 k resistor should be inserted in series with Pin 1 (Pin 9) and Pin 6 (Pin 6) inputs.

IC1312P • CBS SQ DECODER UNIT

APPLICATIONS INFORMATION

FIGURE 4 – DECODING PROCESS DIAGRAM

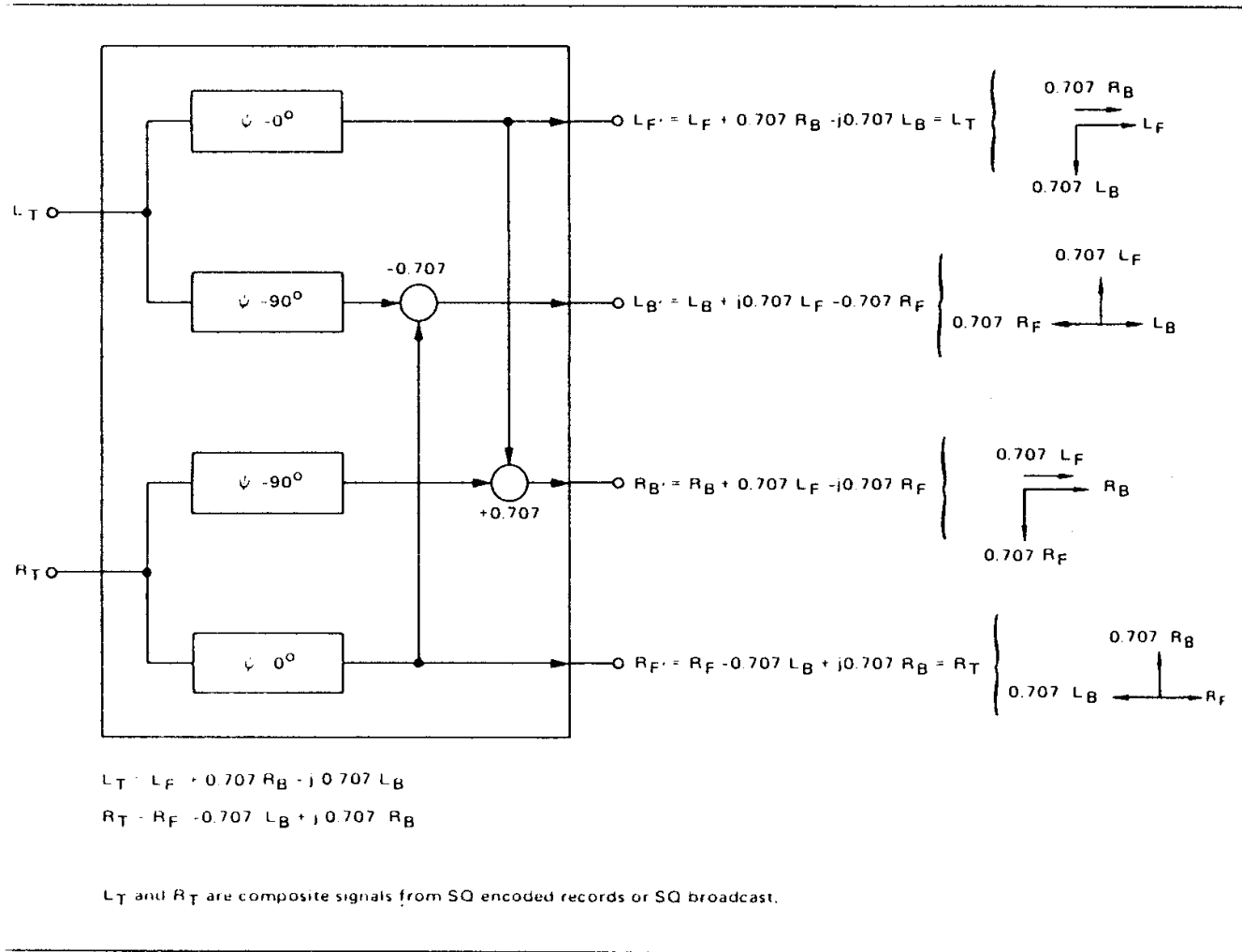

The decoding process is shown schematically in Figure 4. The IC1312P circuits that perform this function consists of two preamplifiers which are fed with left total,  $L_T$ , and right total,  $R_T$ , signals. The preamplifiers each feed two all-pass\* networks that are used to generate two  $L_T$  signals in quadrature and two  $R_T$  signals in quadrature. The four signals are matrixed to yield left-front, left-back, right-front, and right-back signals ( $L_F'$ ,  $L_B'$ ,  $R_F'$ ,  $R_B'$ ).

The all-pass networks are of the Wein bridge form with the resistive arms realized in the integrated circuit and the RC arms formed by external components. The values shown in Figure 1 are for a 100-Hz to 10-kHz bandwidth and a phase ripple of  $\pm 8.5^\circ$  at a  $90^\circ$  phase difference.

It is generally desirable to enhance center-front to center-back separation. This is accomplished by connecting a resistor between pins 2 and 11 (front outputs) and a resistor between pins 3 and 4 (back outputs). For a 10% front channel blending† and a 40% back channel blending†, 47 kilohms between pins 2 and 11 and

7.5 kilohms between pins 3 and 14 is required and results in the following equations:

$$\begin{aligned} R_F'' &= 0.912 L_T + 0.088 R_T \\ L_F'' &= 0.912 R_T + 0.088 L_T \\ R_B'' &= \frac{\sqrt{2}}{2} [0.714 (J R_T - L_T) + 0.286 (R_T - J L_T)] \\ L_B'' &= \frac{\sqrt{2}}{2} [0.714 (J L_T - R_T) + 0.286 (L_T - J R_T)] \end{aligned}$$

To meet the EIA matrix standards with 10/40 blend use the circuit of Figure 5, which results in the following equations:

$$\begin{aligned} R_F'' &= 0.772 (0.995 R_T + 0.0972 L_T) \\ L_F'' &= 0.772 (0.995 L_T + 0.0972 R_T) \\ R_B'' &= \frac{\sqrt{2}}{2} (0.769) [0.928 (J R_T - L_T) + 0.372 (R_T - J L_T)] \\ L_B'' &= \frac{\sqrt{2}}{2} (0.769) [0.928 (J L_T - R_T) + 0.372 (L_T - J R_T)] \end{aligned}$$

\*An all-pass network produces phase shift without amplitude variations.

MC1314P • GAIN CONTROL AND BALANCE ADJUSTMENT UNIT

FIGURE 5 – MC1314P TEST CIRCUIT

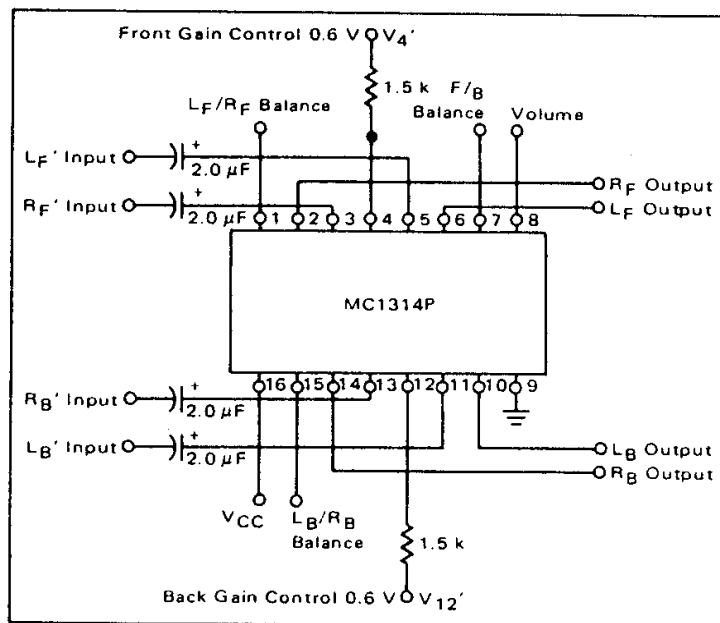

MAXIMUM RATINGS (T<sub>A</sub> = +25°C unless otherwise noted.)

Rating	Value	Unit
Power Supply Voltage	28	Vdc
Input Voltage Swing	±6.0	V <sub>pp</sub>
Volume Control Range	-0.3 to +8.0	V
Balance Control Voltage	-4.0 to +10	V
Output Current Sinking (dc)	0	mA
Output Current Sourcing (dc)	1.0	mA
Power Dissipation @ T <sub>A</sub> = +25°C	750	mW
Derate above +25°C	6.7	mW/°C
Operating Temperature Range	0 to +70	°C
Storage Temperature Range	-65 to +150	°C

ELECTRICAL CHARACTERISTICS (V<sub>CC</sub> = +20 V, V<sub>4'</sub> = V<sub>12'</sub> = 0.60 Vdc, T<sub>A</sub> = +25°C, V<sub>IN</sub> = 1.0 V(rms) @ 1.0 kHz, balance control pins open, unless otherwise noted.)

Characteristic	Min	Typ	Max	Unit
Maximum Gain (V <sub>g</sub> = 6 V)	-1.0	1.0	+3.0	dB
Minimum Gain (V <sub>g</sub> = 0 V)	-60	-	-	dB
Gain Spread @ Gain = Max	-	1.0	3.0	dB
@ Gain = -20 dB	-	-	3.0	dB
@ Gain = -40 dB	-	-	3.0	dB
Signal Handling (THD < 1%)	1.3	-	-	Vrms
Signal Handling (V <sub>4'</sub> = V <sub>12'</sub> = 0.42 Vdc balance controls set for max gain in channel undertest) THD < 1%)	0.4	-	-	Vrms
Total Harmonic Distortion (V <sub>IN</sub> = 0.4 Vrms, max gain)	-	0.2	-	%
Signal/Noise Ratio (20 Hz - 15 kHz Bandwidth) Note 1. V <sub>IN</sub> = 0.4 Vrms (ref)	-	80	-	dB
Channel Separation Note 2	-	60	-	dB
Balance Control Range - 20 dB gain				dB
V <sub>g</sub> = 6.0 V (≈ Max Gain)	-	20	-	
V <sub>g</sub> = 3.0 V (≈ 6.0 dB Gain)	18	26	-	
V <sub>g</sub> = 1.0 V (≈ 20 dB Gain)	-	32	-	
Gain Enhancement (V <sub>4'</sub> = V <sub>12'</sub> = 0.42 Vdc compared to V <sub>4'</sub> = V <sub>12'</sub> = 0.60 Vdc)	2.0	-	4.0	dB
Gain Reduction (V <sub>4'</sub> = V <sub>12'</sub> = 1.86 Vdc compared to V <sub>4'</sub> = V <sub>12'</sub> = 0.60 Vdc)	7.0	-	11	dB
Gain Reduction (V <sub>4'</sub> = V <sub>12'</sub> = 3.12 Vdc compared to V <sub>4'</sub> = V <sub>12'</sub> = 0.60 Vdc, V <sub>CC</sub> = 25 Vdc)	-	14	-	dB
Supply Current (max gain) (V <sub>IN</sub> = 0 V)	-	19	25	mA
(min gain) (V <sub>IN</sub> > 0 V)	-	9.0	15	mA
Input Impedance	-	13	-	kΩ
Output Impedance	-	2.0	-	kΩ
Control Current I <sub>4</sub> or I <sub>12</sub>	-	-20	-	μA
Balance Control Reference Voltage (relative to V <sub>CC</sub> )				%
L <sub>F</sub> /R <sub>F</sub> & L <sub>B</sub> /R <sub>B</sub> Controls (V <sub>11q</sub> /V <sub>CC</sub> & V <sub>15q</sub> /V <sub>CC</sub> )	-	15	-	
F/B Control (V <sub>7q</sub> /V <sub>CC</sub> )	-	13	-	
Intermodulation Distortion (f <sub>1</sub> = 7 kHz, f <sub>2</sub> = 60 Hz)	-	0.6	-	%

Note 1: All Inputs ac shorted

Note 2: Input to 2 Channel Balance Controls

314P • TYPICAL CHARACTERISTICS

RE 6 - ATTENUATION versus CONTROL VOLTAGE

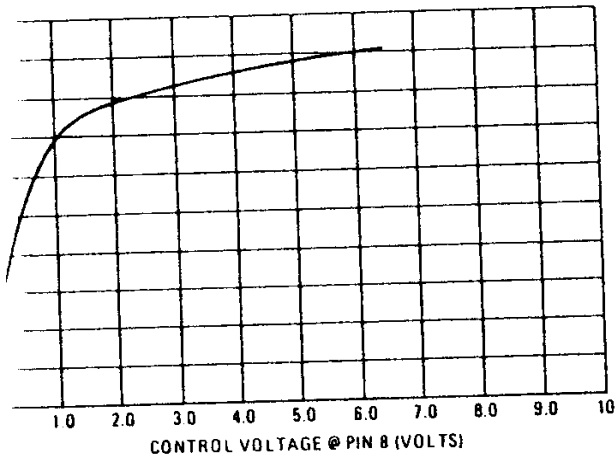
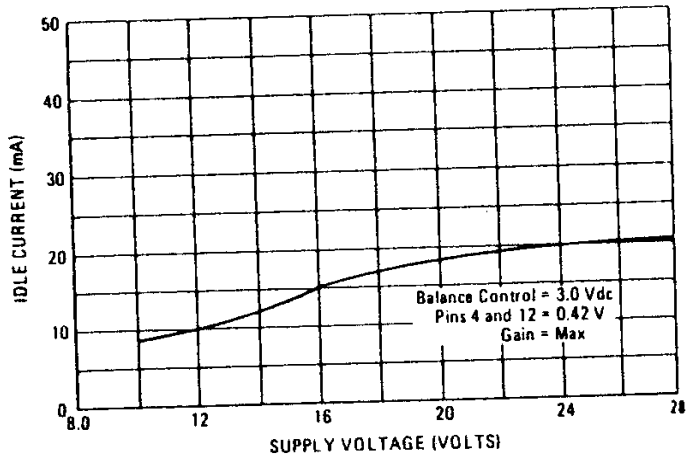

FIGURE 7 - IDLE CURRENT versus SUPPLY VOLTAGE



DISTORTION CHARACTERISTICS

FIGURE 8 - TOTAL HARMONIC DISTORTION versus ATTENUATION

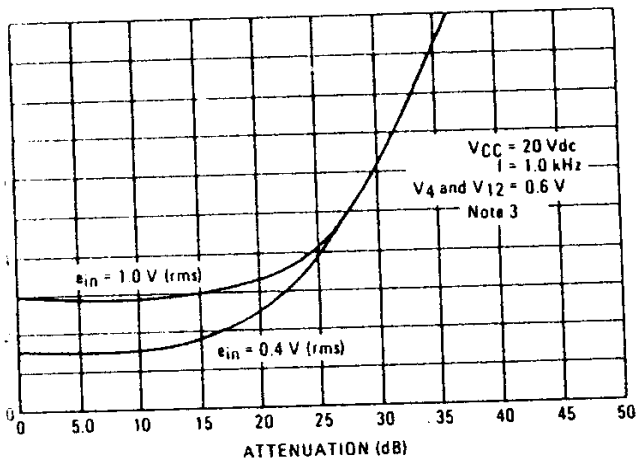

FIGURE 9 - INTERMODULATION DISTORTION versus INPUT VOLTAGE

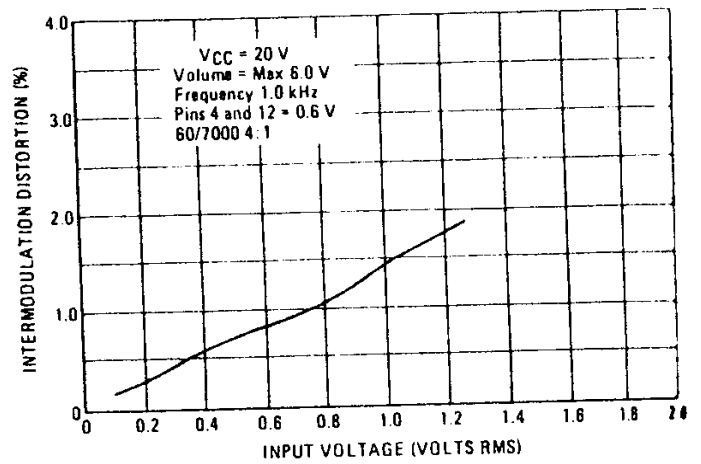

FIGURE 10 - TOTAL HARMONIC DISTORTION versus INPUT VOLTAGE

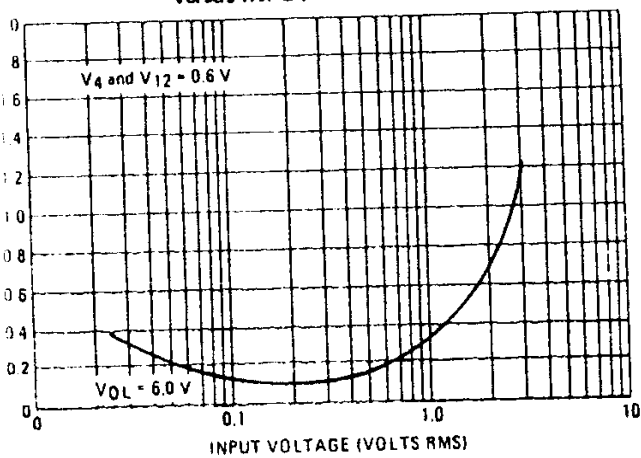
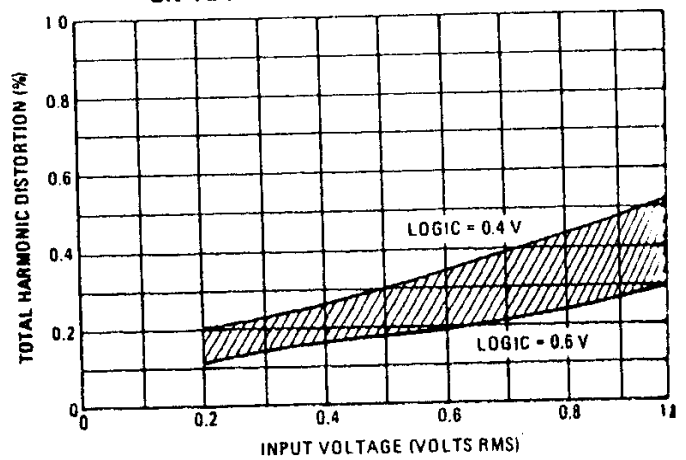

FIGURE 11 - LOGIC VOLTAGE EFFECTS ON TOTAL HARMONIC DISTORTION



# MC1312P, MC1314P, MC1315P

## MC1315P • DC LOGIC ENHANCEMENT CONTROL UNIT

### MAXIMUM RATINGS ( $T_A = +25^{\circ}\text{C}$ unless otherwise noted.)

Rating	Value	Unit
Supply Voltage (Note 1)	25	V
Input Signal Voltage	$\pm 4.0$	V <sub>pk</sub>
Bias Terminal Current	$\pm 2.0$	mA
Output Current	$\pm 2.0$	mA
Power Dissipation @ $T_A = 25^{\circ}\text{C}$	750	mW
Derate above $+25^{\circ}\text{C}$	6.7	mW/ $^{\circ}\text{C}$
Operating Temperature Range	0 to $+70$	$^{\circ}\text{C}$
Storage Temperature Range	$-65$ to $+150$	$^{\circ}\text{C}$

### ELECTRICAL CHARACTERISTICS ( $T_A = +25^{\circ}\text{C}$ , $V_{CC} = 20$ Vdc, Logic Control = 50%, $V_{IN} = 0.5$ Vrms, $f = 2.0$ kHz, unless otherwise noted, Note 1).

Characteristic	Min	Typ	Max	Unit
Supply Current (Pin 12) @ $V_{IN} = 0$	—	7.0	13	mA
@ $V_{IN} = 1.4$ Vrms	—	15	—	mA
Input Resistance @ Pin 1, 15, 16	—	20	—	k $\Omega$
Output Resistance @ Pin 3, 5	—	1.5	—	k $\Omega$
Paraphase Filter Resistance @ Pin 9, 10	—	4.0	—	k $\Omega$
Front-Back Logic Discharge Resistance @ Pin 7, 8	—	5.0	—	k $\Omega$
Bias Voltage (10 k to ground) @ Pin 13	—	1.4	—	Vdc
Logic Control Input Current @ Pin 2 ( $V_2 = V_{13}$ or $V_2 = 0$ )	—	$\pm 0.5$	—	mA
Quiescent Input Voltage ( $V_{IN} = 0$ ) @ Pin 1, 15, 16	—	7.0	—	Vdc
Quiescent Output Voltage ( $V_{IN} = 0$ )	0.48	—	0.72	Vdc
Quiescent Output Offset ( $V_{IN} = 0$ )	—	$\pm 0.02$	$\pm 0.1$	Vdc
Relative Output Change				
Front output with $L_B$ or $R_B$ inputs or back output with $L_F$ or $R_F$ inputs	2.1	2.8	5.0	V/V
	7.5	9.0	14	dB
Back output with $C_F$ input	1.9	2.5	3.5	V/V
	5.5	8.0	11	dB
Front output with $L_F$ , $C_F$ or $R_F$ inputs or back output with $L_B$ , or $R_B$ input	0.8	0.67	0.56	V/V
	2.2	3.5	5.0	dB
AGC Leveling - $V_{IN} = 1.4$ Vrms to $V_{IN} = 50$ mVrms (Note 2) Figure 8 (AGC1, AGC2)	—	1.0	3.0	dB
Quiescent Output Voltage at Max Logic ( $S_1$ in Position 1, Figure 12) ( $V_{IN} = 0$ , $V_2 = V_{13}$ )	0.45	—	0.83	Vdc
Max Logic Relative Output Change ( $V_2 = V_{13}$ )				
Front output with $L_B$ or $R_B$ inputs or back outputs with $L_F$ , $C_F$ or $R_F$ inputs	—	5.0	—	V/V
	—	14	—	dB
Front output with $L_F$ , $C_F$ or $R_F$ inputs or back outputs with $L_B$ or $R_B$ inputs	—	0.67	—	V/V
	—	3.5	—	dB

Note 1: When testing with well regulated supplies, current should be limited to 25 mA.

Note 2: For example, this is the decrease in the back control voltage,  $V_5$  with a right front input signal as this signal is varied from 1.4 Vrms to 50 mVrms.

MC1315P • DC LOGIC ENHANCEMENT CONTROL UNIT

FIGURE 12 – MC1315P TEST CIRCUIT

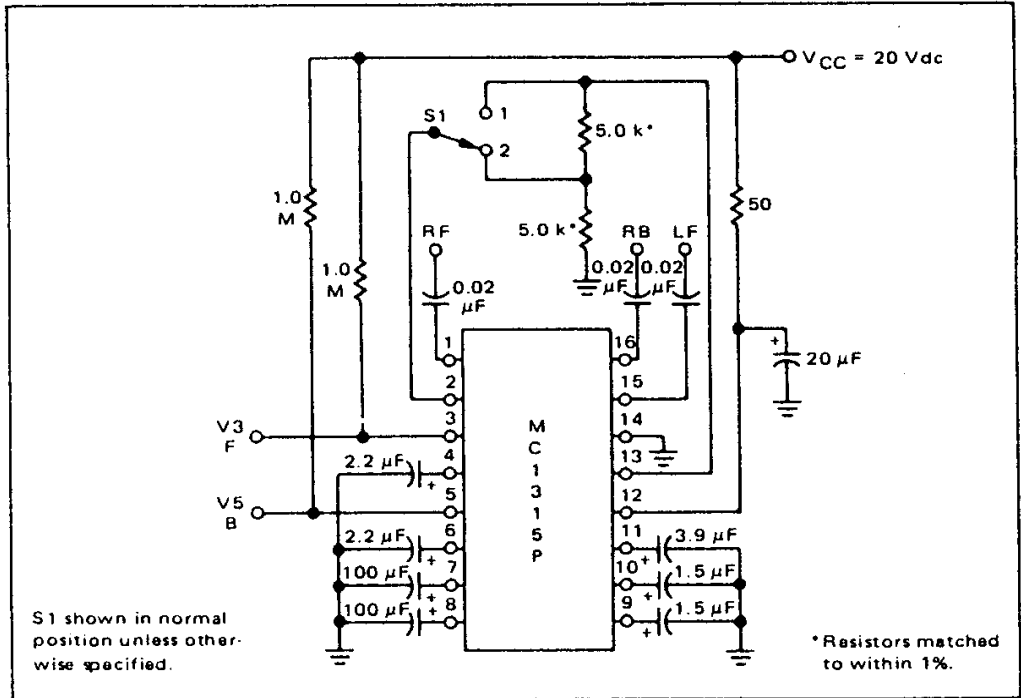

TABLE 1 – DEFINITION OF INPUT SIGNALS: (f = 2.0 kHz)

V <sub>I</sub> Name	Signal Description	Apply To Pin	V <sub>I</sub> Name	Signal Description	Apply To Pin
RF	0.5 V rms /0°	1	CF	0.35 V rms /0°	1
	0.35 V rms /-90°	16		0.35 V rms /-45°	16
	(1)	15		0.35 V rms /0°	15
LF	(1)	1			
	0.35 V rms /0°	16			
	0.5 V rms /0°	15			
LB	0.35 V rms /180°	1	AGC1	(1)	15
	(1)	16		1.0 V rms /-90°	16
	0.35 V rms /-90°	15		1.4 V rms /0°	1
RB	0.35 V rms /90°	1	AGC2	(1)	15
	0.5 V rms /0°	16		35 mV rms /-90°	16
	0.35 V rms /0°	15		50 mV rms /0°	1

(1) All unused inputs shall be ac grounded.  
 (2) This signal not used at present.

# MC1312P, MC1314P, MC1315P

## MC1315P • DC LOGIC ENHANCEMENT CONTROL UNIT

### WHY LOGIC?

Enhances front to back separation from 6 dB to 20 dB.

Front-to-back separation of SQ material can be enhanced by the MC1315 logic circuit which detects the presence of dominant front or back signals and adjusts the front-back gain relationship of the MC1314P to enhance the relative gain of the dominant channels.

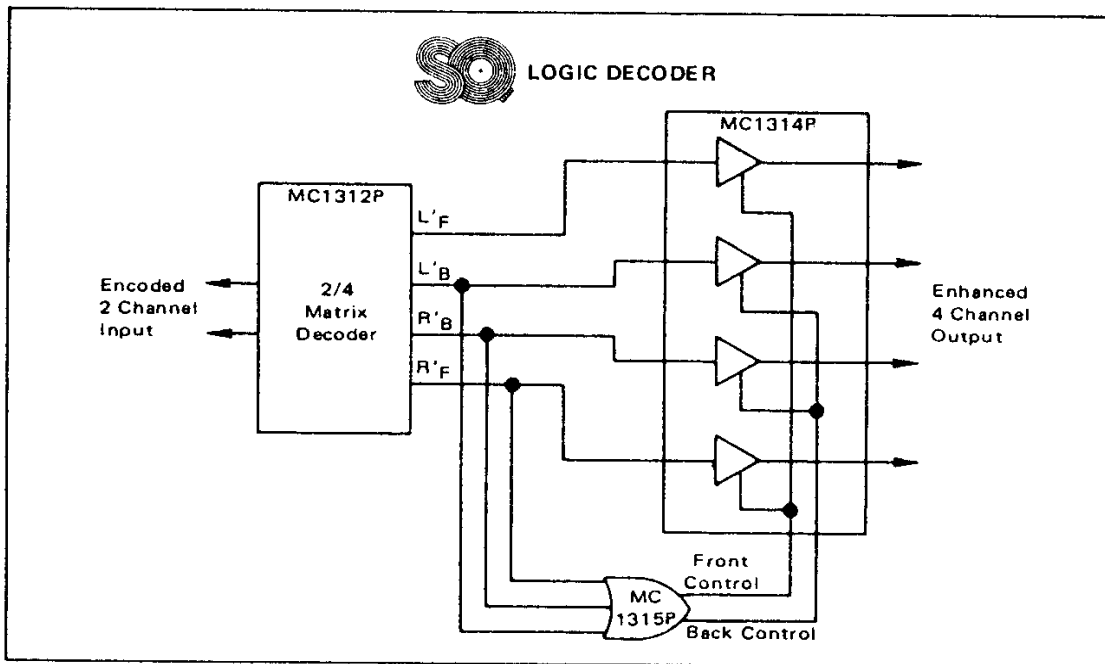

Front and back control voltages (from the MC1315P) are connected to the MC1314P. Although the relative gains of the front and back channels are altered with these control signals, they vary in a complementary manner to maintain constant power output from the MC1314P.

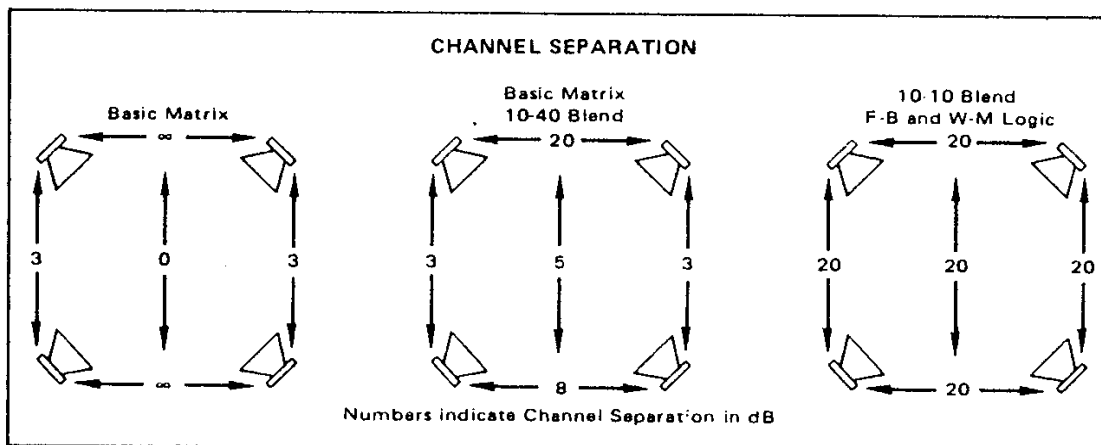



C1312P, MC1314P, MC1315P

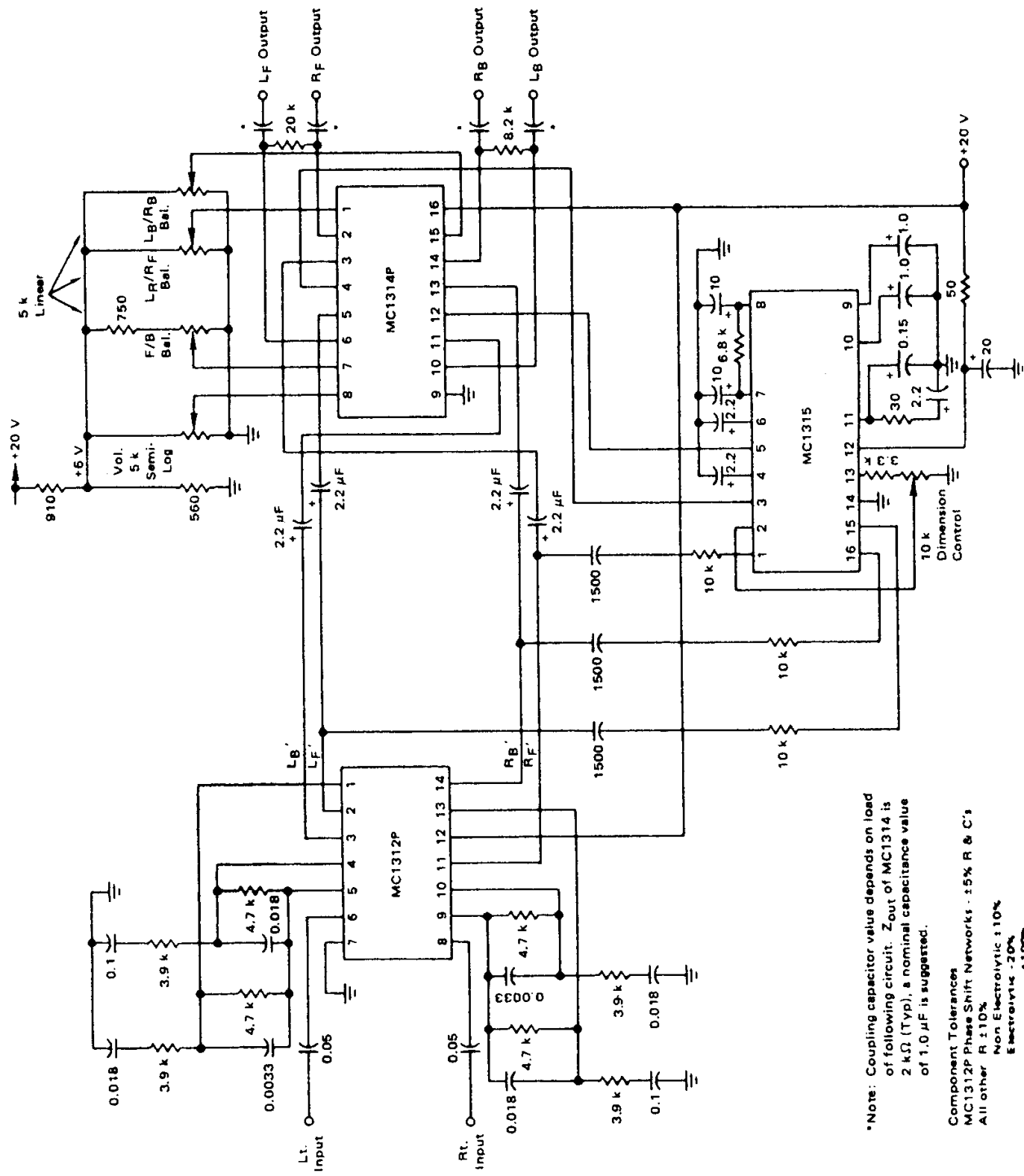

\*Note: Coupling capacitor value depends on load of following circuit. Zout of MC1314 is 2 kΩ (Typ), a nominal capacitance value of 1.0 μF is suggested.

Component Tolerances  
 MC1312P Phase Shift Networks: ±5% R & C's  
 All other R ±10%  
 Non Electrolytic ±10%  
 Electrolytic ±20%  
 ±100%

FIGURE 14 - CBS LOGIC SYSTEM WITH VARIABLE BLEND (L2a)

NOTES: (Unless otherwise specified)

1. Q1,2,3,4,9 are MPS-A18
2. Q5 is 2N5461
3. Q7,8,10 are MPS-A55
4. All Diodes are 1N456
5. Vol. Semi-Log: F/B Bal., Lf/Rf Bal.; Lf/Rg Bal. are 5 k Linear Pots
6. All Capacitors Marked\* are 5% Tolerance
7. Coupling Capacitor Value Depend on Load of Following Circuit (1.0  $\mu$ F Nominal is Suggested).
8. Adjust 250  $\Omega$  Rheostat so that Q9 is Conducting for an Input of  $L_T = 0.5$  VRMS and  $R_T = 0.08$  VRMS @ 1 kHz. With  $L_T = 0.5$  VRMS and  $R_T = 0.06$ , Q9 should be Cut-Off.
9. Power Supply: +20 Vdc @ 75 mA
10. All Resistor Values are in Ohms, 1/4 Watt, 5%.

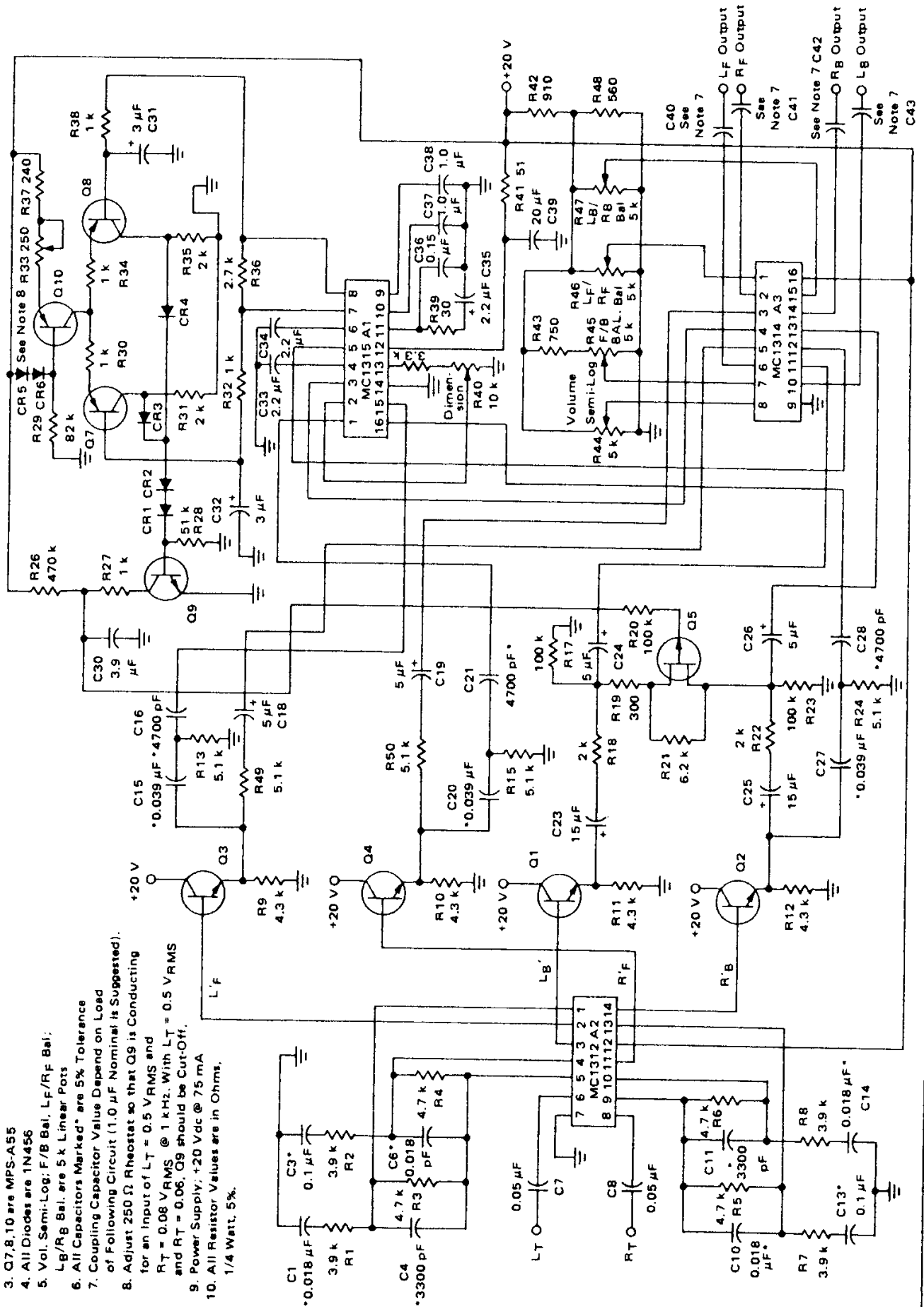

TYPICAL SYSTEM PERFORMANCE CHARACTERISTICS (MC1312P, MC1314P, MC1315P)

Power Supply Requirements:	60 mA (L1a), 75 mA (L2a) @ 20 V
Nominal Signal Level:	0.5 V
Maximum Input Voltage:	1.9 V
Input Impedance:	2 MΩ
Output Impedance:	2 kΩ
Total Harmonic Distortion:	0.2% at nominal input
at 1 Hz	1.0% at maximum input
Voltage Gain (at quiescent):	1.0
4 Channel Volume Control	Range - 70 dB
	Tracking - within 3 dB
4 Channel Balance Control:	-35 dB at -20 dB gain

NOTES

MC1314P

1. If volume control is not used, connect Pin 8 to +6.0 V.
2. If balance controls are not used, open Pins 1, 7 and 15.
3.  $L_F/R_F$  and  $L_B/R_B$  balance controls can be ganged by connecting Pins 1 and 15.
4. Signal handling capability is reduced at maximum logic (20 dB front to back separation) unless  $V_{CC} = 25 V$  on MC1314.

MC1315P

1. The logic control will provide enhancement of front to back separation from 6 dB typical to 20 dB max (15 dB typical at the recommended operating level of 50% control).
2. To defeat the logic use the circuit connections as shown on right.

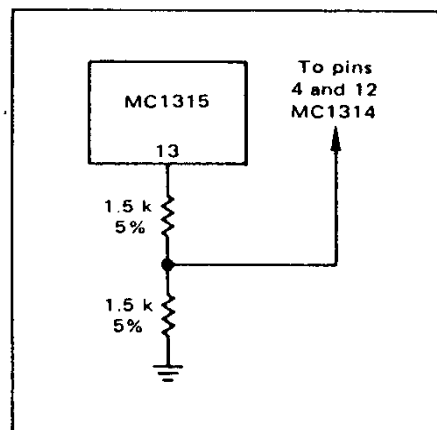

SYSTEM CHARACTERISTICS

FIGURE 15 – GAIN versus F/B BALANCE

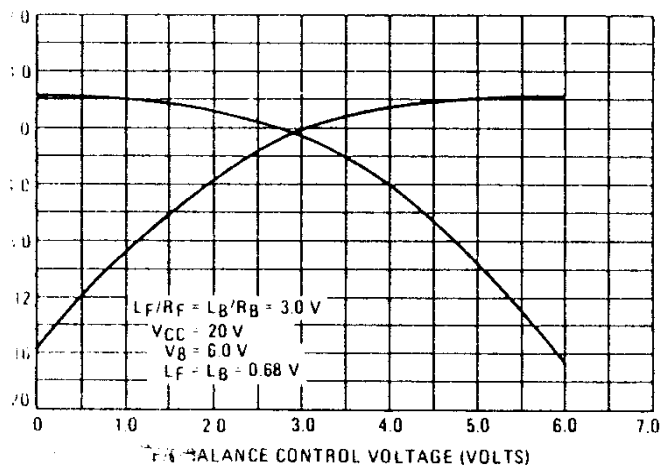
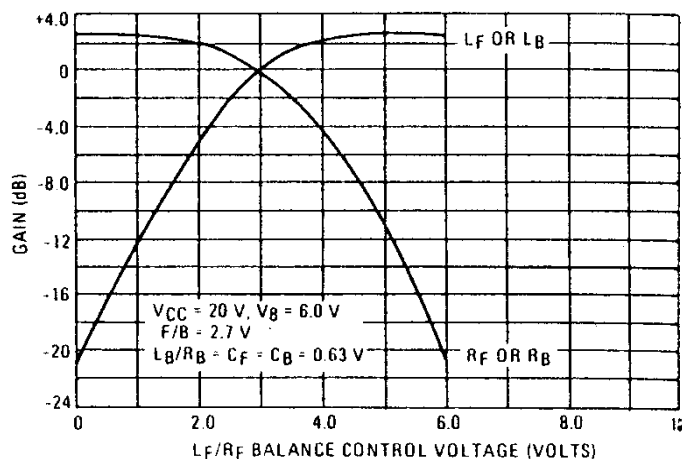

FIGURE 16 – GAIN versus  $L_F/R_F$  BALANCE CONTROL



# MC1312P, MC1314P, MC1315P

## Signal Definitions for Total System

Test signals shall have the following relative phase and amplitude characteristics.

Source Location	Input Signals	
	L <sub>T</sub>	R <sub>T</sub>
L <sub>F</sub>	1	0
C <sub>F</sub>	.71	.71
R <sub>F</sub>	0	1
L <sub>B</sub>	.71/ <u>-90°</u>	.71/ <u>180°</u>
R <sub>B</sub>	.71	.71/ <u>90°</u>

Where L<sub>F</sub> is left front, R<sub>B</sub> is right back, C<sub>F</sub> is center front, etc.

### 1. System Tests: MC1312P, MC1314P, MC1315P

- L<sub>F</sub> source - connect signal to L<sub>T</sub> input, ac ground R<sub>T</sub> input of MC1312P.
- R<sub>F</sub> source - apply signal to R<sub>T</sub>, ac ground L<sub>T</sub>.
- C<sub>F</sub> source - apply equal signals to L<sub>T</sub> and R<sub>T</sub> inputs.

NOTES: Balance control inputs of MC1314 may be opened for convenience or set for perfect balance with C<sub>F</sub> and C<sub>B</sub> inputs; set logic control to 50%. Max signal should be limited to 1.6 V<sub>rms</sub> L<sub>T</sub> or R<sub>T</sub>: MC1314P outputs give system performance, typically 15 dB front back separation for corners, 12 dB for center front, center back.

### 2. Logic Circuit Tests: MC1315P

- L<sub>F</sub> source - apply  $L_{F'} = \sqrt{2} R_{B'}$ ,  $R_{F'} = 0$ ; dc voltage at Pin 3 should decrease by 3 dB, at Pin 5 should increase by 9 dB.
- R<sub>B</sub> source - apply  $R_{F'} = \sqrt{2} R_{B'}$ ,  $R_{F'} = 0$ ; dc voltage at Pin 3 should increase by 9 dB, at Pin 5 should decrease by 3 dB.

### 3. Voltage Controlled Amplifier Tests: MC1314P

- Volume control - with balance controls open or balanced, gain should be +0.5 dB at 6 V on Pin 8 and less than -60 dB at 0 V.
- Balance controls - with balance controls at Pins 1 and 15 at 15% of supply and Pin 7 at 13% of supply, system is nominally balanced. Taking Pin 1 to ground should increase L<sub>F</sub> gain by 3 dB and decrease R<sub>F</sub> gain by greater than 12 dB at maximum volume and 30 dB at lower volume levels.