

300 mA/600 mA up to 42V Input Step-Down DC/DC Regulator in Thin SOT-23

General Description

The LM2841 and LM2842 are PWM DC/DC buck (step-down) regulators. With a wide input range from 4.5V-42V, they are suitable for a wide range of applications such as power conditioning from unregulated sources. They feature a low $R_{DS(ON)}$ (0.9 Ω typical) internal switch for maximum efficiency (85% typical). Operating frequency is fixed at 550 kHz (X version) and 1.25 MHz (Y version) allowing the use of small external components while still being able to have low output voltage ripple. Soft-start can be implemented using the shutdown pin with an external RC circuit allowing the user to tailor the soft-start time to a specific application.

The LM2842 is optimized for up to 600 mA load currents while the LM2841 is optimized for up to 300 mA load current. Both have a 0.765V nominal feedback voltage.

Additional features include: thermal shutdown, V_{IN} under-voltage lockout, and gate drive under-voltage lockout. The LM2841 and LM2842 are available in a low profile TSOT-6L package.

Features

- Input voltage range of 4.5V to 42V
- Output current options of 300 mA and 600 mA
- Feedback pin voltage of 0.765V
- 550 kHz (X) or 1.25 Mhz (Y) switching frequency
- Low shutdown I_Q , 16 μ A typical
- Short circuit protected
- Internally compensated
- Soft-start circuitry
- Small overall solution size (TSOT-6L package)

Applications

- Battery powered equipment
- Industrial distributed power applications
- Portable media players
- Portable hand held instruments

Typical Application Circuit

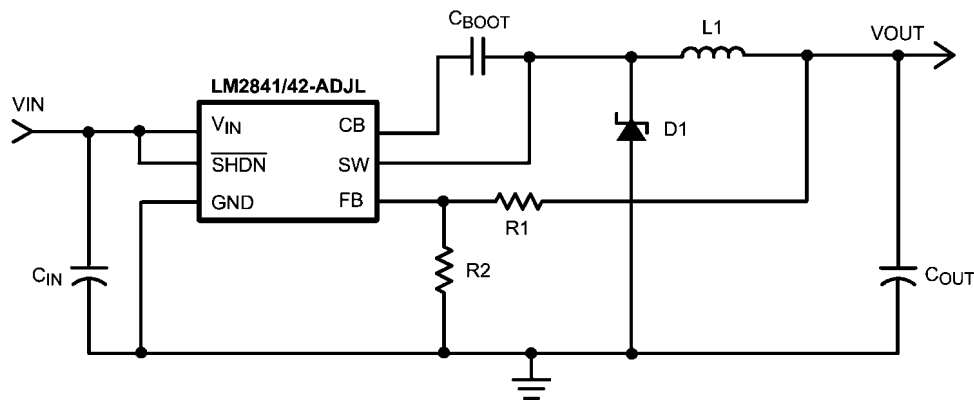

30036702

Connection Diagram

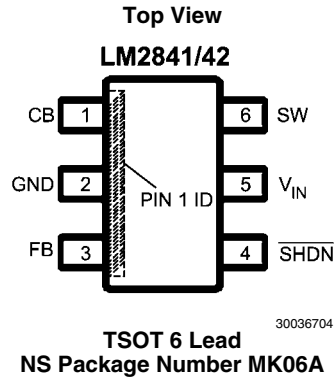

Ordering Information

Order Number	Spec.	Package Type	NSC Package Drawing	Top Mark	Supplied As
LM2841XMK-ADJL	NOPB	TSOT-6	MK06A	STFB	1000 Units, Tape and Reel
LM2841XMKX-ADJL					3000 Units, Tape and Reel
LM2841YMK-ADJL				STTB	1000 Units, Tape and Reel
LM2841YMKX-ADJL					3000 Units, Tape and Reel
LM2842XMK-ADJL				STVB	1000 Units, Tape and Reel
LM2842XMKX-ADJL					3000 Units, Tape and Reel
LM2842YMK-ADJL				STXB	1000 Units, Tape and Reel
LM2842YMKX-ADJL					3000 Units, Tape and Reel

Pin Descriptions

Pin	Name	Function
1	CB	SW FET gate bias voltage. Connect C_{BOOT} cap between CB and SW.
2	GND	Ground connection.
3	FB	Feedback pin: Set feedback voltage divider ratio with $V_{OUT} = V_{FB} (1+(R1/R2))$. Resistors should be in the 100-10K range to avoid input bias errors.
4	SHDN	Logic level shutdown input. Pull to GND to disable the device and pull high to enable the device. If this function is not used tie to V_{IN} or leave open.
5	V_{IN}	Power input voltage pin: 4.5V to 42V normal operating range.
6	SW	Power FET output: Connect to inductor, diode, and C_{BOOT} cap.

Block Diagram

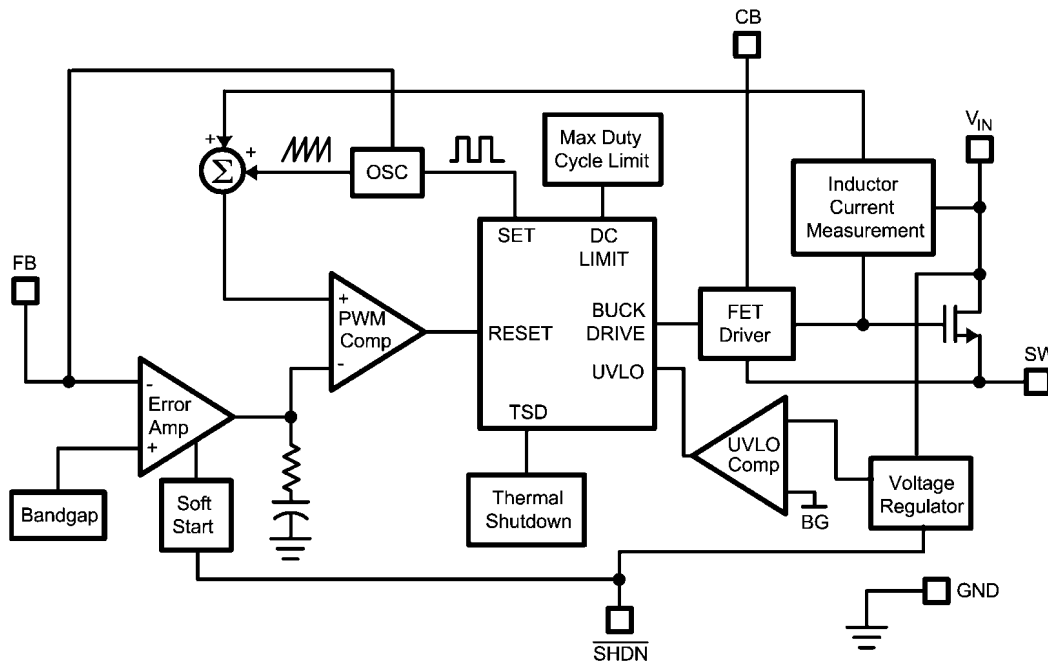

30036703

Absolute Maximum Ratings (Note 1)

If Military/Aerospace specified devices are required, please contact the National Semiconductor Sales Office/ Distributors for availability and specifications.

V_{IN}	-0.3V to +45V
\overline{SHDN}	-0.3V to ($V_{IN}+0.3V$) $\overline{SHDN}=V_{IN}$ at 45V max
SW Voltage	-0.3V to +45V
CB Voltage above SW Voltage	7V
FB Voltage	-0.3V to +5V
Maximum Junction Temperature	150°C
Power Dissipation(Note 2)	Internally Limited

Lead Temperature	300°C
Vapor Phase (60 sec.)	215°C
Infrared (15 sec.)	220°C
ESD Susceptibility (Note 3)	
Human Body Model	1.5 kV

Operating Conditions

Operating Junction Temperature Range (Note 4)	-40°C to +125°C
Storage Temperature	-65°C to +150°C
Input Voltage V_{IN}	4.5V to 42V
SW Voltage	Up to 42V

Electrical Characteristics

Specifications in standard type face are for $T_J = 25^\circ\text{C}$ and those with **boldface type** apply over the full **Operating Temperature Range** ($T_J = -40^\circ\text{C}$ to $+125^\circ\text{C}$). Minimum and Maximum limits are guaranteed through test, design, or statistical correlation. Typical values represent the most likely parametric norm at $T_J = +25^\circ\text{C}$, and are provided for reference purposes only. Unless otherwise stated the following conditions apply: $V_{IN} = 12V$.

Symbol	Parameter	Conditions	Min(Note 4)	Typ(Note 5)	Max(Note 4)	Units
I_Q	Quiescent current	$\overline{SHDN} = 0V$		16	40	μA
		Device On, Not Switching		1.30	1.75	mA
		Device On, No Load		1.35	1.85	
R_{DSON}	Switch ON resistance	(Note 6)		0.9	1.6	Ω
I_{LSW}	Switch leakage current	$V_{IN} = 42V$		0.0	0.5	μA
I_{CL}	Switch current limit	LM2842 (Note 7)		1.15		A
		LM2841 (Note 7)		525		mA
I_{FB}	Feedback pin bias current	LM2841/42 (Note 8)		0.1	1.0	μA
V_{FB}	FB Pin reference voltage		0.747	0.765	0.782	V
t_{MIN}	Minimum ON time			100		ns
f_{SW}	Switching frequency	LM2841/42X, $V_{FB} = 0.5V$	325	550	750	kHz
		LM2841/42X, $V_{FB} = 0V$		140		
		LM2841/42Y, $V_{FB} = 0.5V$	0.95	1.25	1.50	MHz
		LM2841/42Y, $V_{FB} = 0V$		0.35		
D_{MAX}	Maximum duty cycle	LM2841/42X	88	94		%
		LM2841/42Y	81	87		
V_{UVP}	Undervoltage lockout thresholds	On threshold	4.4	3.7		V
		Off threshold		3.5	3.25	
$V_{\overline{SHDN}}$	Shutdown threshold	Device on	2.3	1.0		V
		Device off		0.9	0.3	
$I_{\overline{SHDN}}$	Shutdown pin input bias current	$V_{\overline{SHDN}} = 2.3V$ (Note 8)		0.05	1.5	μA
		$V_{\overline{SHDN}} = 0V$		0.02	1.5	

THERMAL SPECIFICATIONS

$R_{\theta JA}$	Junction-to-Ambient Thermal Resistance, TSOT-6L Package	(Note 9)		121		$^\circ\text{C/W}$
-----------------	---	----------	--	-----	--	--------------------

Note 1: Absolute maximum ratings are limits beyond which damage to the device may occur. Operating Ratings are conditions for which the device is intended to be functional, but device parameter specifications may not be guaranteed. For guaranteed specifications and test conditions, see the Electrical Characteristics.

Note 2: The maximum allowable power dissipation is a function of the maximum junction temperature, $T_{J(MAX)}$, the junction-to-ambient thermal resistance, θ_{JA} , and the ambient temperature, T_A . The maximum allowable power dissipation at any ambient temperature is calculated using: $P_D (MAX) = (T_{J(MAX)} - T_A) / \theta_{JA}$. Exceeding the maximum allowable power dissipation will cause excessive die temperature, and the regulator will go into thermal shutdown. Internal thermal shutdown circuitry protects the device from permanent damage. Thermal shutdown engages at $T_J=175^\circ\text{C}$ (typ.) and disengages at $T_J=155^\circ\text{C}$ (typ).

Note 3: Human Body Model, applicable std. JESD22-A114-C.

Note 4: All limits guaranteed at room temperature (standard typeface) and at temperature extremes (bold typeface). All room temperature limits are 100% production tested. All limits at temperature extremes are guaranteed via correlation using standard Statistical Quality Control (SQC) methods. All limits are used to calculate Average Outgoing Quality Level (AOQL).

Note 5: Typical numbers are at 25°C and represent the most likely norm.

Note 6: Includes the bond wires, $R_{DS(ON)}$ from V_{IN} pin to SW pin.

Note 7: Current limit at 0% duty cycle.

Note 8: Bias currents flow into pin.

Note 9: All numbers apply for packages soldered directly onto a 3" x 3" PC board with 2 oz. copper on 4 layers in still air in accordance to JEDEC standards. Thermal resistance varies greatly with layout, copper thickness, number of layers in PCB, power distribution, number of thermal vias, board size, ambient temperature, and air flow.

Typical Performance Characteristics

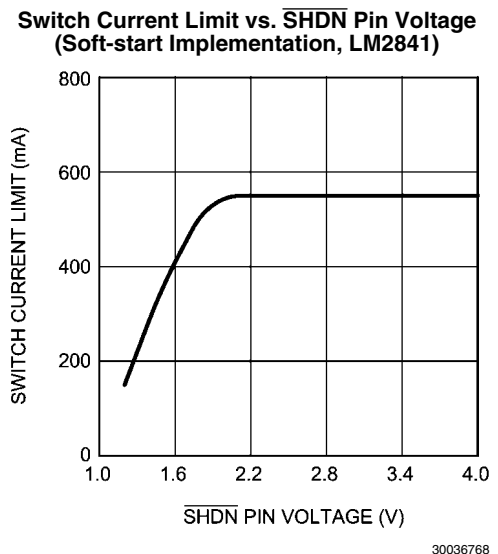
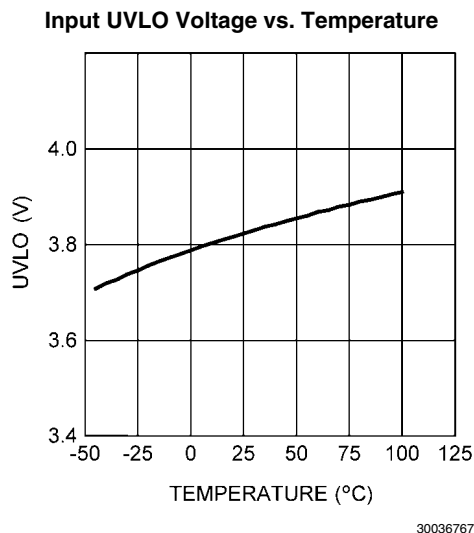
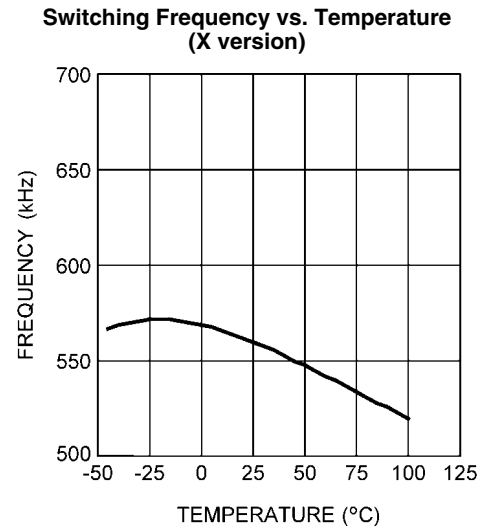
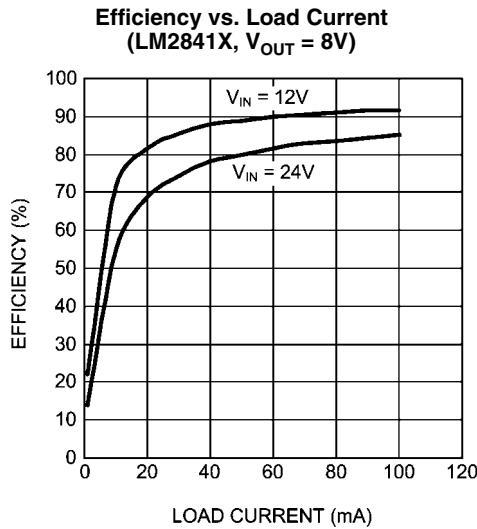
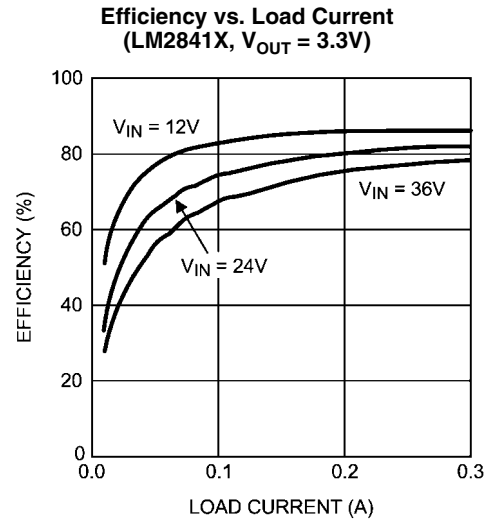
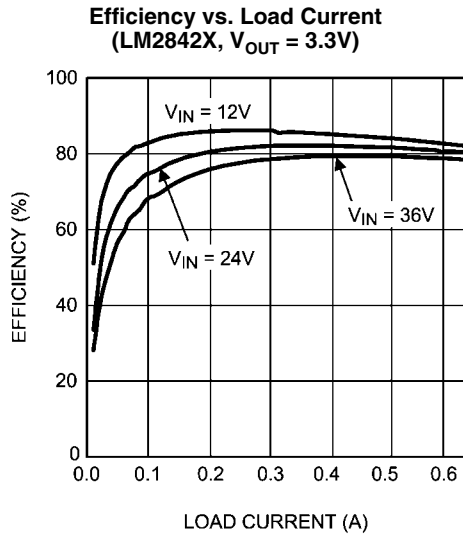

Switch Current Limit vs. $\overline{\text{SHDN}}$ Pin Voltage
(Soft-start Implementation, LM2842)

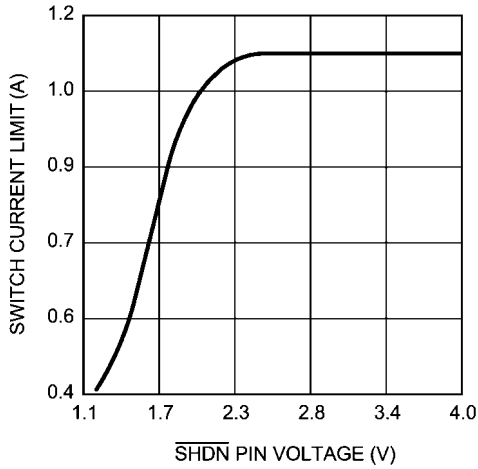

30036721

$\overline{\text{SHDN}}$ Pin Current vs. $\overline{\text{SHDN}}$ Pin Voltage

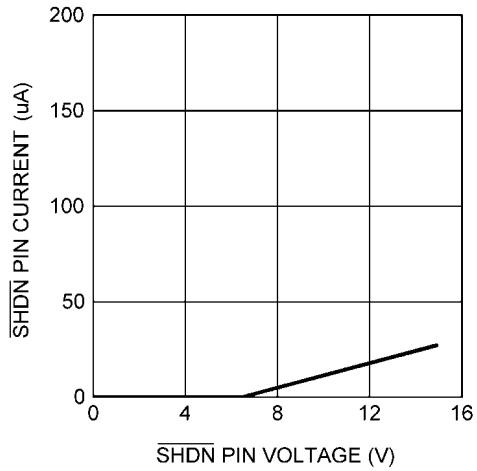

30036769

Switching Node and Output Voltage Waveforms

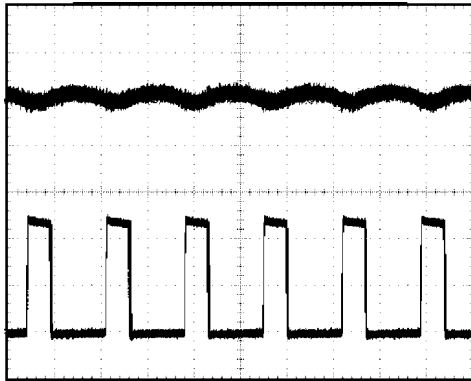

30036770

$V_{\text{IN}} = 12\text{V}$, $V_{\text{OUT}} = 3.3\text{V}$, $I_{\text{OUT}} = 200\text{ mA}$
 Top trace: V_{OUT} , 10 mV/div, AC Coupled
 Bottom trace: SW, 5V/div, DC Coupled
 T = 400 ns/div

Load Transient Waveforms

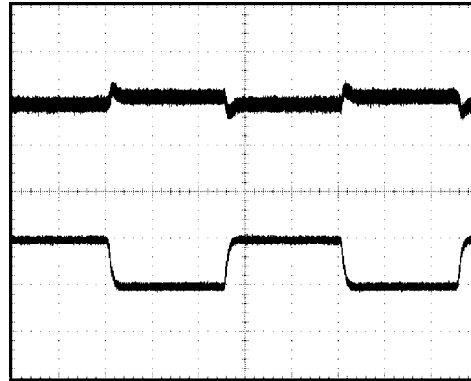

30036771

$V_{\text{IN}} = 12\text{V}$, $V_{\text{OUT}} = 3.3\text{V}$, $I_{\text{OUT}} = 300\text{ mA to } 200\text{ mA to } 300\text{ mA}$
 Top trace: V_{OUT} , 20 mV/div, AC Coupled
 Bottom trace: I_{OUT} , 100 mA/div, DC Coupled
 T = 200 μs /div

Start-up Waveform

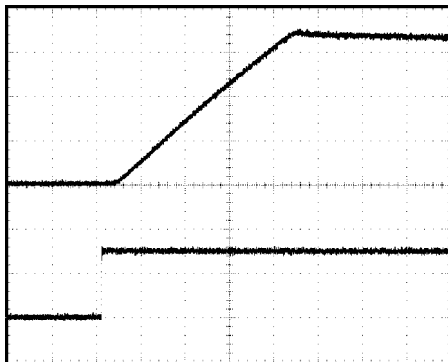

30036772

$V_{\text{IN}} = 12\text{V}$, $V_{\text{OUT}} = 3.3\text{V}$, $I_{\text{OUT}} = 50\text{ mA}$
 Top trace: V_{OUT} , 1V/div, DC Coupled
 Bottom trace: $\overline{\text{SHDN}}$, 2V/div, DC Coupled
 T = 40 μs /div

Operation

PROTECTION

The LM2841/42 has dedicated protection circuitry running during normal operation to protect the IC. The thermal shutdown circuitry turns off the power device when the die temperature reaches excessive levels. The UVLO comparator protects the power device during supply power startup and shutdown to prevent operation at voltages less than the minimum input voltage. A gate drive (CB) under-voltage lockout is included to guarantee that there is enough gate drive voltage to drive the MOSFET before the device tries to start switching. The LM2841/42 also features a shutdown mode decreasing the supply current to approximately 16 μ A.

CONTINUOUS CONDUCTION MODE

The LM2841/42 contains a current-mode, PWM buck regulator. A buck regulator steps the input voltage down to a lower output voltage. In continuous conduction mode (when the inductor current never reaches zero at steady state), the buck regulator operates in two cycles. The power switch is connected between V_{IN} and SW. In the first cycle of operation the transistor is closed and the diode is reverse biased. Energy is collected in the inductor and the load current is supplied by C_{OUT} and the rising current through the inductor. During the second cycle the transistor is open and the diode is forward biased due to the fact that the inductor current cannot instantaneously change direction. The energy stored in the inductor is transferred to the load and output capacitor. The ratio of these two cycles determines the output voltage. The output voltage is defined approximately as: $D = V_{OUT}/V_{IN}$ and $D' = (1 - D)$ where D is the duty cycle of the switch. D and D' will be required for design calculations.

DESIGN PROCEDURE

This section presents guidelines for selecting external components.

SETTING THE OUTPUT VOLTAGE

The output voltage is set using the feedback pin and a resistor divider connected to the output as shown on the front page schematic. The feedback pin voltage is 0.762V, so the ratio of the feedback resistors sets the output voltage according to the following equation: $V_{OUT} = 0.765V(1 + (R1/R2))$ Typically R2 will be given as 100 Ω -10 k Ω for a starting value. To solve for R1 given R2 and V_{OUT} use $R1 = R2((V_{OUT}/0.765V) - 1)$.

INPUT CAPACITOR

A low ESR ceramic capacitor (C_{IN}) is needed between the V_{IN} pin and GND pin. This capacitor prevents large voltage transients from appearing at the input. Use a 2.2 μ F-10 μ F value with X5R or X7R dielectric. Depending on construction, a ceramic capacitor's value can decrease up to 50% of its nominal value when rated voltage is applied. Consult with the capacitor manufacturer's data sheet for information on capacitor derating over voltage and temperature.

INDUCTOR SELECTION

The most critical parameters for the inductor are the inductance, peak current, and the DC resistance. The inductance is related to the peak-to-peak inductor ripple current, the input and the output voltages.

$$L = \frac{(V_{IN} - V_{OUT})V_{OUT}}{V_{IN} \times I_{RIPPLE} \times f_{SW}}$$

A higher value of ripple current reduces inductance, but increases the conductance loss, core loss, and current stress for the inductor and switch devices. It also requires a bigger output capacitor for the same output voltage ripple requirement. A reasonable value is setting the ripple current to be 30% of the DC output current. Since the ripple current increases with the input voltage, the maximum input voltage is always used to determine the inductance. The DC resistance of the inductor is a key parameter for the efficiency. Lower DC resistance is available with a bigger winding area. A good tradeoff between the efficiency and the core size is letting the inductor copper loss equal 2% of the output power. See AN-1197 for more information on selecting inductors. A good starting point for most applications is a 10 μ H to 22 μ H with 1.1A or greater current rating for the LM2842 or a 0.7A or greater current rating for the LM2841. Using such a rating will enable the LM2841/42 to current limit without saturating the inductor. This is preferable to the LM2841/42 going into thermal shutdown mode and the possibility of damaging the inductor if the output is shorted to ground or other longterm overload.

OUTPUT CAPACITOR

The selection of C_{OUT} is driven by the maximum allowable output voltage ripple. The output ripple in the constant frequency, PWM mode is approximated by: $V_{RIPPLE} = I_{RIPPLE} (ESR + (1/8f_{SW}C_{OUT}))$ The ESR term usually plays the dominant role in determining the voltage ripple. Low ESR ceramic capacitors are recommended. Capacitors in the range of 22 μ F-100 μ F are a good starting point with an ESR of 0.1 Ω or less.

BOOTSTRAP CAPACITOR

A 0.15 μ F ceramic capacitor or larger is recommended for the bootstrap capacitor (C_{BOOT}). For applications where the input voltage is less than twice the output voltage a larger capacitor is recommended, generally 0.15 μ F to 1 μ F to ensure plenty of gate drive for the internal switches and a consistently low R_{DSON} .

SOFT-START COMPONENTS

The LM2841/42 has circuitry that is used in conjunction with the \overline{SHDN} pin to limit the inrush current on start-up of the DC/DC switching regulator. The \overline{SHDN} pin in conjunction with a RC filter is used to tailor the soft-start for a specific application. When a voltage applied to the \overline{SHDN} pin is between 0V and up to 2.3V it will cause the cycle by cycle current limit in the power stage to be modulated for minimum current limit at 0V up to the rated current limit at 2.3V. Thus controlling the output rise time and inrush current at startup. The resistor value should be selected so the current sourced into the \overline{SHDN} pin will be greater than the leakage current of the \overline{SHDN} pin (1.5 μ A) when the voltage at \overline{SHDN} is equal or greater than 2.3V.

SHUTDOWN OPERATION

The \overline{SHDN} pin of the LM2841/42 is designed so that it may be controlled using 2.3V or higher logic signals. If the shutdown function is not to be used the \overline{SHDN} pin may be tied to V_{IN} . The maximum voltage to the \overline{SHDN} pin should not exceed 42V. If the use of a higher voltage is desired due to system or other constraints it may be used, however a 100 k Ω or larger resistor is recommended between the applied voltage and the \overline{SHDN} pin to protect the device.

SCHOTTKY DIODE

The breakdown voltage rating of the diode (D1) is preferred to be 25% higher than the maximum input voltage. The cur-

rent rating for the diode should be equal to the maximum output current for best reliability in most applications. In cases where the input voltage is much greater than the output voltage the average diode current is lower. In this case it is possible to use a diode with a lower average current rating, approximately $(1-D)I_{OUT}$, however the peak current rating should be higher than the maximum load current. A 0.5A to 1A rated diode is a good starting point.

LAYOUT CONSIDERATIONS

To reduce problems with conducted noise pick up, the ground side of the feedback network should be connected directly to the GND pin with its own connection. The feedback network, resistors R1 and R2, should be kept close to the FB pin, and away from the inductor to minimize coupling noise into the

feedback pin. The input bypass capacitor C_{IN} must be placed close to the V_{IN} pin. This will reduce copper trace resistance which effects input voltage ripple of the IC. The inductor L1 should be placed close to the SW pin to reduce magnetic and electrostatic noise. The output capacitor, C_{OUT} should be placed close to the junction of L1 and the diode D1. The L1, D1, and C_{OUT} trace should be as short as possible to reduce conducted and radiated noise and increase overall efficiency. The ground connection for the diode, C_{IN} , and C_{OUT} should be as small as possible and tied to the system ground plane in only one spot (preferably at the C_{OUT} ground point) to minimize conducted noise in the system ground plane. For more detail on switching power supply layout considerations see Application Note AN-1149: *Layout Guidelines for Switching Power Supplies*.

Application Information

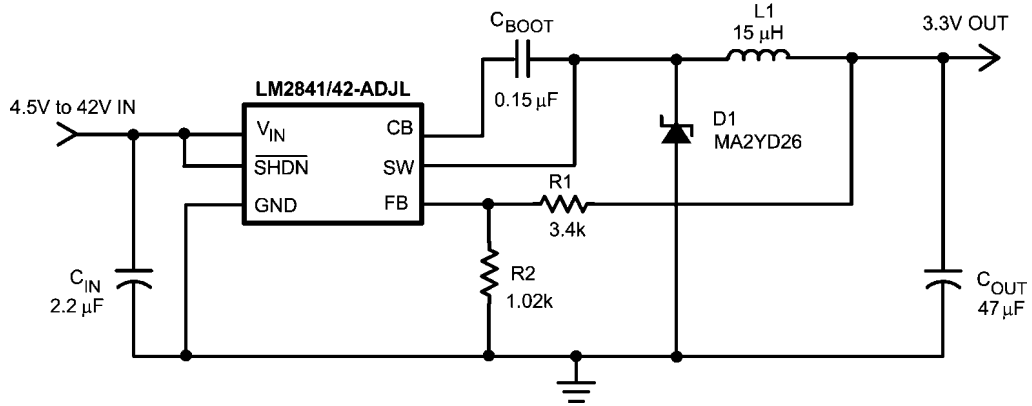

30036705

FIGURE 1. Application Circuit, 3.3V Output

Some Recommended Inductors (Others May Be Used)

Manufacturer	Inductor	Contact Information
Coilcraft	LPS4018, DO1608C, DO3308, and LPO2506 series	www.coilcraft.com 800-3222645
MuRata	LQH55D and LQH66S series	www.murata.com
Coiltronics	MP2 and MP2A series	www.cooperbusman.com

Some Recommended Input And Output Capacitors (Others May Be Used)

Manufacturer	Capacitor	Contact Information
Vishay Sprague	293D, 592D, and 595D series tantalum	www.vishay.com 407-324-4140
Taiyo Yuden	High capacitance MLCC ceramic	www.t-yuden.com 408-573-4150
Cornell Dubilier	ESRD series Polymer Aluminum Electrolytic SPV and AFK series V-chip series	www.cde.com
MuRata	High capacitance MLCC ceramic	www.murata.com

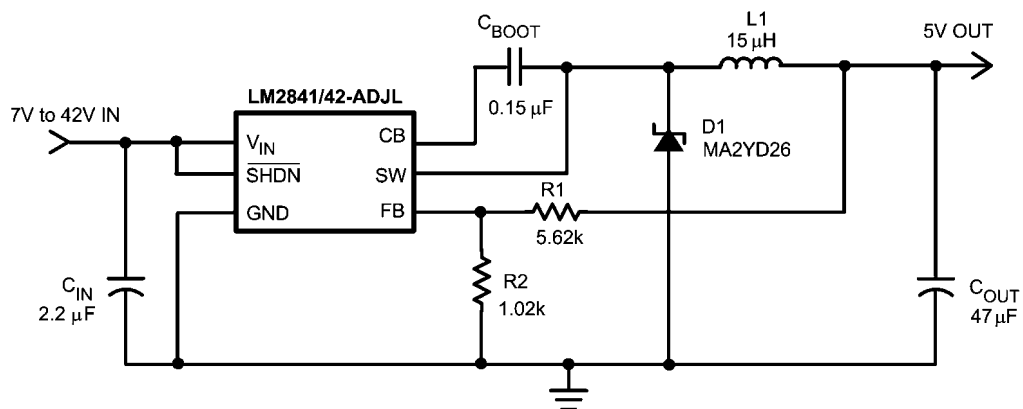

30036708

FIGURE 2. Application Circuit, 5V Output

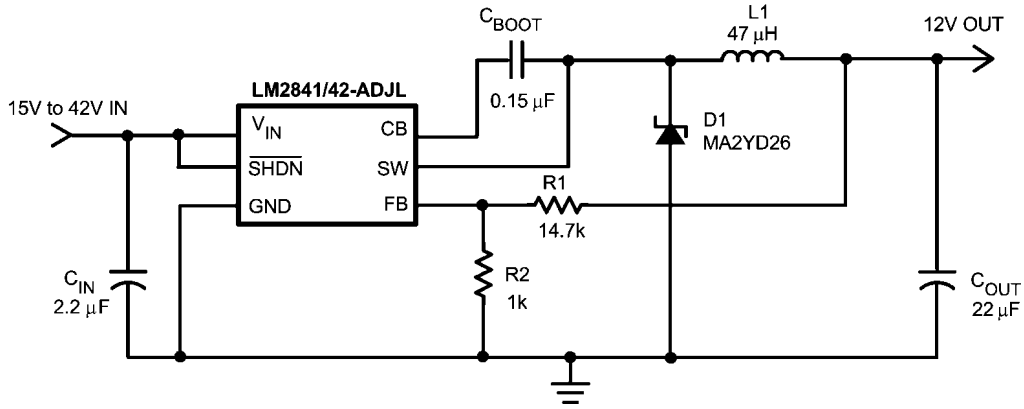

30036709

FIGURE 3. Application Circuit, 12V Output

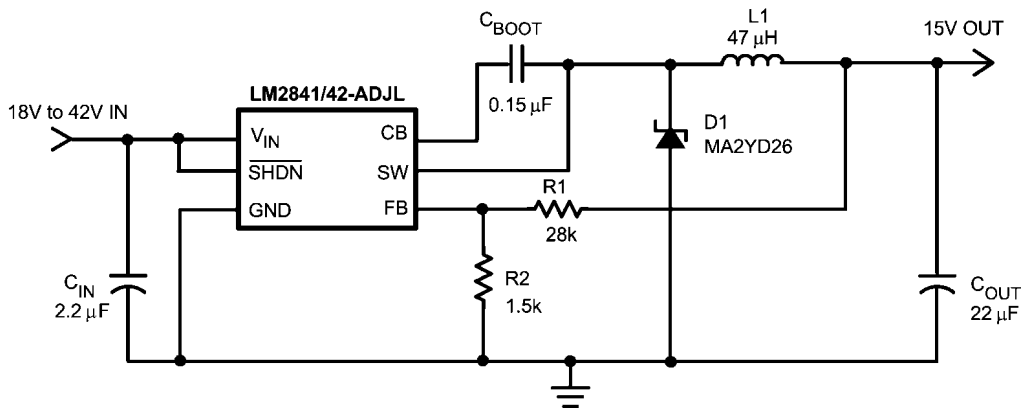

30036716

FIGURE 4. Application Circuit, 15V Output

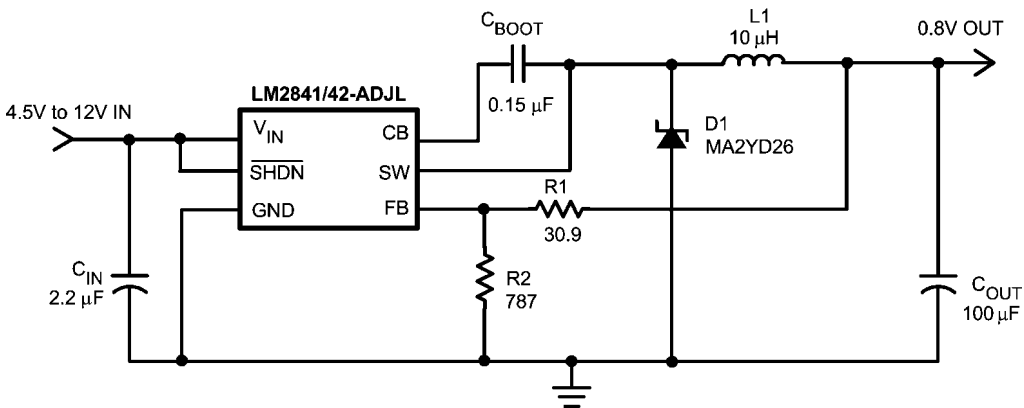

30036717

FIGURE 5. Application Circuit, 0.8V Output

Physical Dimensions inches (millimeters) unless otherwise noted

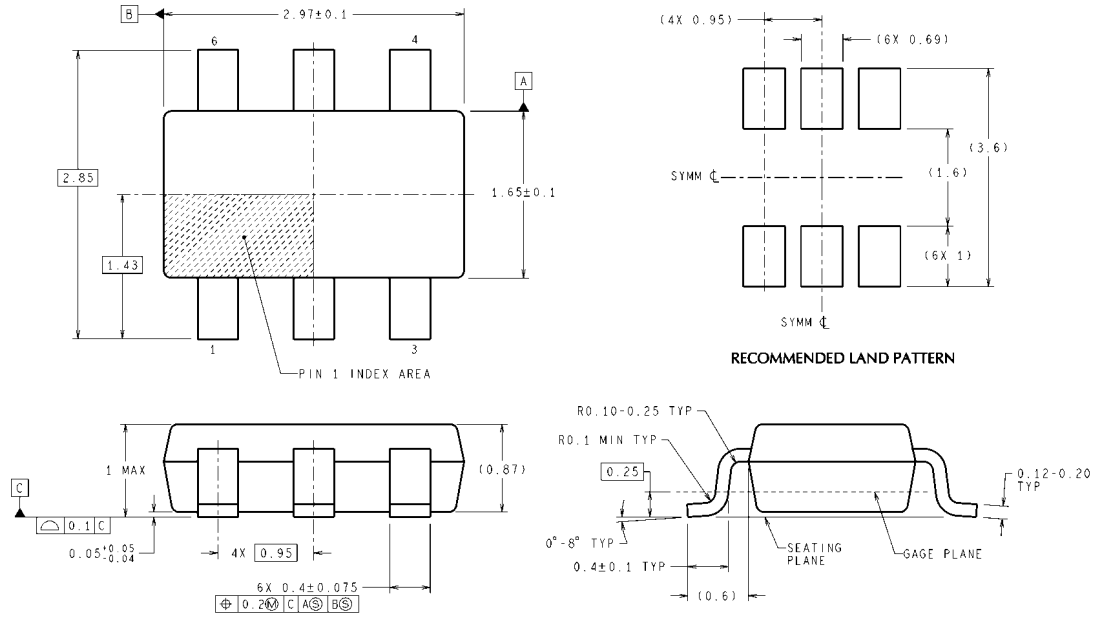

DIMENSIONS ARE IN MILLIMETERS

MK06A (Rev E)

TSOT 6 Pin Package (MK)
For Ordering, Refer to Ordering Information Table
NS Package Number MK06A

Notes

LM2841 / LM2842

Notes

For more National Semiconductor product information and proven design tools, visit the following Web sites at:

Products		Design Support	
Amplifiers	www.national.com/amplifiers	WEBENCH® Tools	www.national.com/webench
Audio	www.national.com/audio	App Notes	www.national.com/appnotes
Clock and Timing	www.national.com/timing	Reference Designs	www.national.com/refdesigns
Data Converters	www.national.com/adc	Samples	www.national.com/samples
Interface	www.national.com/interface	Eval Boards	www.national.com/evalboards
LVDS	www.national.com/lvds	Packaging	www.national.com/packaging
Power Management	www.national.com/power	Green Compliance	www.national.com/quality/green
Switching Regulators	www.national.com/switchers	Distributors	www.national.com/contacts
LDOs	www.national.com/ldo	Quality and Reliability	www.national.com/quality
LED Lighting	www.national.com/led	Feedback/Support	www.national.com/feedback
Voltage Reference	www.national.com/vref	Design Made Easy	www.national.com/easy
PowerWise® Solutions	www.national.com/powerwise	Solutions	www.national.com/solutions
Serial Digital Interface (SDI)	www.national.com/sdi	Mil/Aero	www.national.com/milaero
Temperature Sensors	www.national.com/tempsensors	SolarMagic™	www.national.com/solarmagic
Wireless (PLL/VCO)	www.national.com/wireless	Analog University®	www.national.com/AU

THE CONTENTS OF THIS DOCUMENT ARE PROVIDED IN CONNECTION WITH NATIONAL SEMICONDUCTOR CORPORATION ("NATIONAL") PRODUCTS. NATIONAL MAKES NO REPRESENTATIONS OR WARRANTIES WITH RESPECT TO THE ACCURACY OR COMPLETENESS OF THE CONTENTS OF THIS PUBLICATION AND RESERVES THE RIGHT TO MAKE CHANGES TO SPECIFICATIONS AND PRODUCT DESCRIPTIONS AT ANY TIME WITHOUT NOTICE. NO LICENSE, WHETHER EXPRESS, IMPLIED, ARISING BY ESTOPPEL OR OTHERWISE, TO ANY INTELLECTUAL PROPERTY RIGHTS IS GRANTED BY THIS DOCUMENT.

TESTING AND OTHER QUALITY CONTROLS ARE USED TO THE EXTENT NATIONAL DEEMS NECESSARY TO SUPPORT NATIONAL'S PRODUCT WARRANTY. EXCEPT WHERE MANDATED BY GOVERNMENT REQUIREMENTS, TESTING OF ALL PARAMETERS OF EACH PRODUCT IS NOT NECESSARILY PERFORMED. NATIONAL ASSUMES NO LIABILITY FOR APPLICATIONS ASSISTANCE OR BUYER PRODUCT DESIGN. BUYERS ARE RESPONSIBLE FOR THEIR PRODUCTS AND APPLICATIONS USING NATIONAL COMPONENTS. PRIOR TO USING OR DISTRIBUTING ANY PRODUCTS THAT INCLUDE NATIONAL COMPONENTS, BUYERS SHOULD PROVIDE ADEQUATE DESIGN, TESTING AND OPERATING SAFEGUARDS.

EXCEPT AS PROVIDED IN NATIONAL'S TERMS AND CONDITIONS OF SALE FOR SUCH PRODUCTS, NATIONAL ASSUMES NO LIABILITY WHATSOEVER, AND NATIONAL DISCLAIMS ANY EXPRESS OR IMPLIED WARRANTY RELATING TO THE SALE AND/OR USE OF NATIONAL PRODUCTS INCLUDING LIABILITY OR WARRANTIES RELATING TO FITNESS FOR A PARTICULAR PURPOSE, MERCHANTABILITY, OR INFRINGEMENT OF ANY PATENT, COPYRIGHT OR OTHER INTELLECTUAL PROPERTY RIGHT.

LIFE SUPPORT POLICY

NATIONAL'S PRODUCTS ARE NOT AUTHORIZED FOR USE AS CRITICAL COMPONENTS IN LIFE SUPPORT DEVICES OR SYSTEMS WITHOUT THE EXPRESS PRIOR WRITTEN APPROVAL OF THE CHIEF EXECUTIVE OFFICER AND GENERAL COUNSEL OF NATIONAL SEMICONDUCTOR CORPORATION. As used herein:

Life support devices or systems are devices which (a) are intended for surgical implant into the body, or (b) support or sustain life and whose failure to perform when properly used in accordance with instructions for use provided in the labeling can be reasonably expected to result in a significant injury to the user. A critical component is any component in a life support device or system whose failure to perform can be reasonably expected to cause the failure of the life support device or system or to affect its safety or effectiveness.

National Semiconductor and the National Semiconductor logo are registered trademarks of National Semiconductor Corporation. All other brand or product names may be trademarks or registered trademarks of their respective holders.

Copyright© 2009 National Semiconductor Corporation

For the most current product information visit us at www.national.com



National Semiconductor Americas Technical Support Center
 Email: support@nsc.com
 Tel: 1-800-272-9959

National Semiconductor Europe Technical Support Center
 Email: europe.support@nsc.com

National Semiconductor Asia Pacific Technical Support Center
 Email: ap.support@nsc.com

National Semiconductor Japan Technical Support Center
 Email: jpn.feedback@nsc.com