

## Features

- Six Half-bridge Outputs Formed by Six High-side and Six Low-side Drivers
- Capable of Switching all Kinds of Loads (Such as DC Motors, Bulbs, Resistors, Capacitors and Inductors)
- $R_{DSon}$  Typically  $1.0\Omega$  at  $25^{\circ}\text{C}$ , Maximum  $1.8\Omega$  at  $150^{\circ}\text{C}$
- Up to 950-mA Output Current
- Very Low Total Quiescent Current  $I_S < 2\mu\text{A}$  in Standby Mode
- Outputs Short-circuit Protected
- Overtemperature Prewarning and Protection
- Undervoltage Protection
- Various Diagnosis Functions Such as Shorted Output, Open Load, Overtemperature and Power Supply Fail
- Serial Data Interface
- Operation Voltage up to 40V
- Daisy Chaining Possible
- Serial Interface 5V Compatible, up to 2MHz Clock Frequency
- QFN24  $5\text{mm} \times 5\text{mm}$  Power Package

## 1. Description

The Atmel<sup>®</sup> ATA6838C is a fully protected hex half-bridge driver designed in Smart Power SOI technology, used to control up to six different loads by a microcontroller in automotive and industrial applications.

Each of the six high-side and six low-side drivers is capable of driving currents up to 950mA. The drivers are internally connected to form six half-bridges and can be controlled separately from a standard serial data interface. Therefore, all kinds of loads, such as bulbs, resistors, capacitors and inductors, can be combined. The IC especially supports the application of H-bridges to drive DC motors.

Protection is guaranteed in terms of short-circuit conditions, overtemperature and undervoltage. Various diagnosis functions and a very low quiescent current in standby mode make a wide range of applications possible.

Automotive qualification referring to conducted interferences, EMC protection and ESD protection gives added value and enhanced quality for the exacting requirements of automotive applications.



## Hex Half-bridge Driver with Serial Input Control

Atmel ATA6838C

Preliminary



Figure 1-1. Block Diagram QFN24

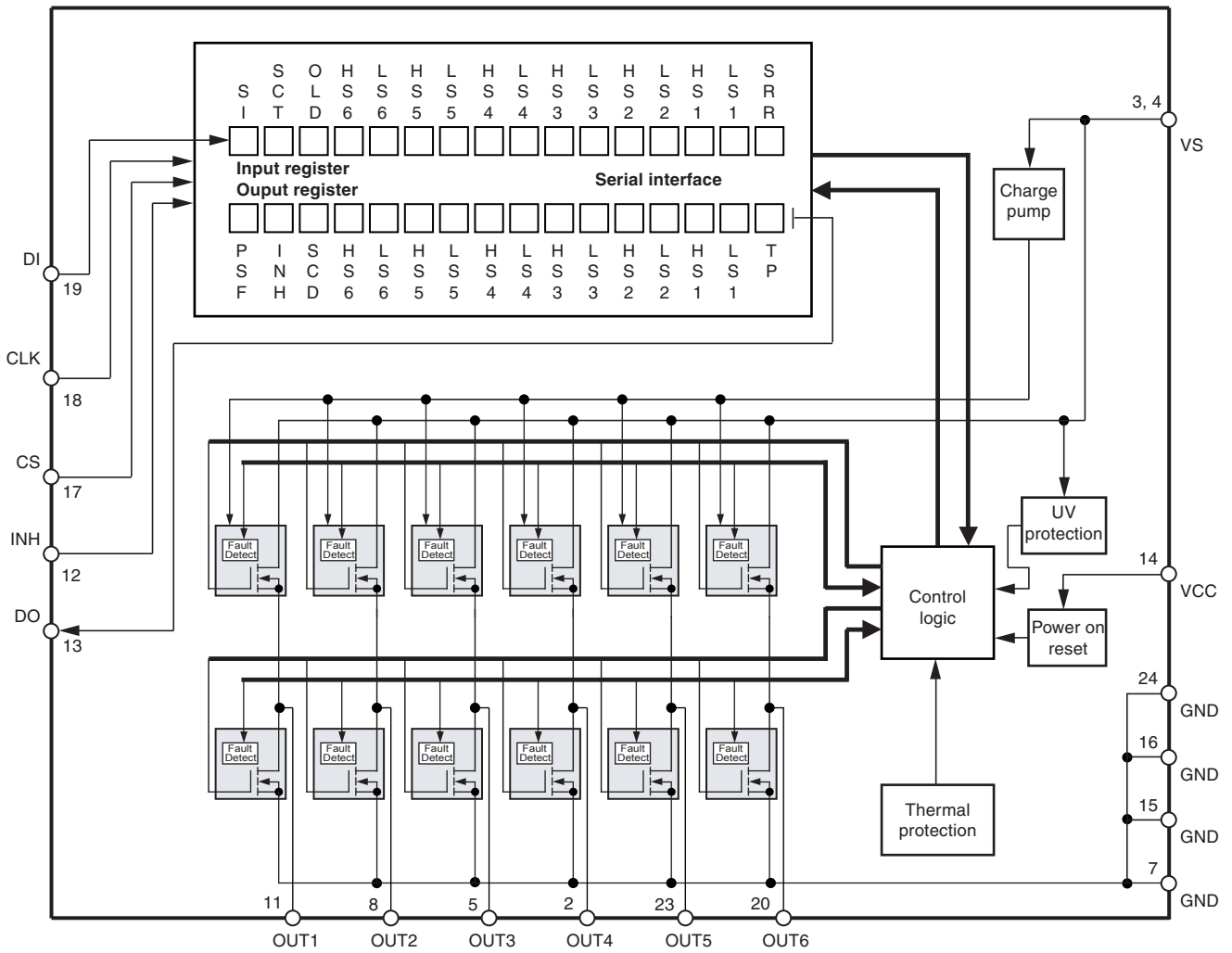

## 2. Pin Configuration

### 2.1 QFN24

**Figure 2-1.** Pinning QFN 24, 5 × 5, 0.65mm pitch

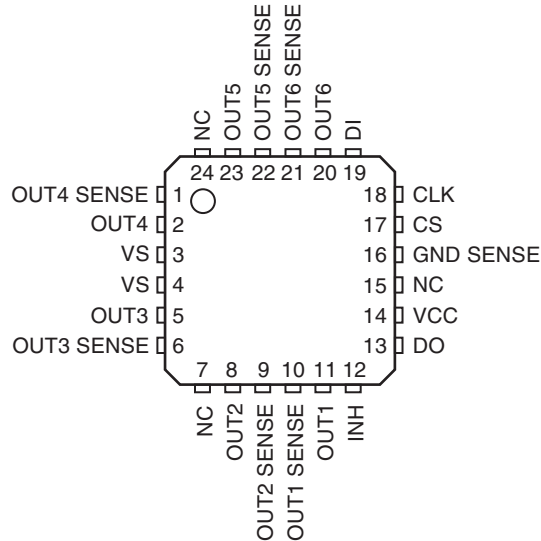

Note: YWW Date code (Y = Year above 2000, WW = week number)  
 ATAxyz Product name  
 ZZZZZ Wafer lot number  
 AL Assembly sub-lot number

**Table 2-1.** Pin Description QFN24

Pin	Symbol	Function
1	OUT4 SENSE	Only for testability in final test
2	OUT4	Half-bridge output 4; formed by internally connected power MOS high-side switch 4 and low-side switch 4 with internal reverse diodes; short circuit protection; overtemperature protection; diagnosis for short and open load
3	VS	Power supply output stages HS4, HS5 and HS6
4	VS	Power supply output stages HS1, HS2 and HS3
5	OUT3	Output 3; see pin 1
6	OUT3 SENSE	Only for testability in final test
7	NC	Internal bond to GND
8	OUT2	Output 2; see pin 1
9	OUT2 SENSE	Only for testability in final test
10	OUT1 SENSE	Only for testability in final test
11	OUT1	Output 1; see pin 1
12	INH	Inhibit input; 5V logic input with internal pull down; low = standby, high = normal operation
13	DO	Serial data output; 5V CMOS logic level tri-state output for output (status) register data; sends 16-bit status information to the microcontroller (LSB is transferred first). Output will remain tri-stated unless device is selected by CS = low, therefore, several ICs can operate on one data output line only

**Table 2-1.** Pin Description QFN24 (Continued)

Pin	Symbol	Function
14	VCC	Logic supply voltage (5V)
15	NC	Internal bond to GND
16	GND SENSE	Ground; reference potential; internal connection to the lead frame; cooling tab
17	CS	Chip select input; 5V CMOS logic level input with internal pull up; low = serial communication is enabled, high = disabled
18	CLK	Serial clock input; 5V CMOS logic level input with internal pull down; controls serial data input interface and internal shift register ( $f_{max} = 2\text{MHz}$ )
19	DI	Serial data input; 5V CMOS logic level input with internal pull down; receives serial data from the control device; DI expects a 16-bit control word with LSB being transferred first
20	OUT6	Output 6; see pin 1
21	OUT6 SENSE	Only for testability in final test
22	OUT5 SENSE	Only for testability in final test
23	OUT5	Output 5; see pin 1
24	NC	Internal bond to GND

## 3. Functional Description

### 3.1 Serial Interface

Data transfer starts with the falling edge of the CS signal. Data must appear at DI synchronized to CLK and is accepted on the falling edge of the CLK signal. LSB (bit 0, SRR) has to be transferred first. Execution of new input data is enabled on the rising edge of the CS signal. When CS is high, pin DO is in a tri-state condition. This output is enabled on the falling edge of CS. Output data will change their state with the rising edge of CLK and stay stable until the next rising edge of CLK appears. LSB (bit 0, TP) is transferred first.

**Figure 3-1.** Data Transfer Input Data Protocol

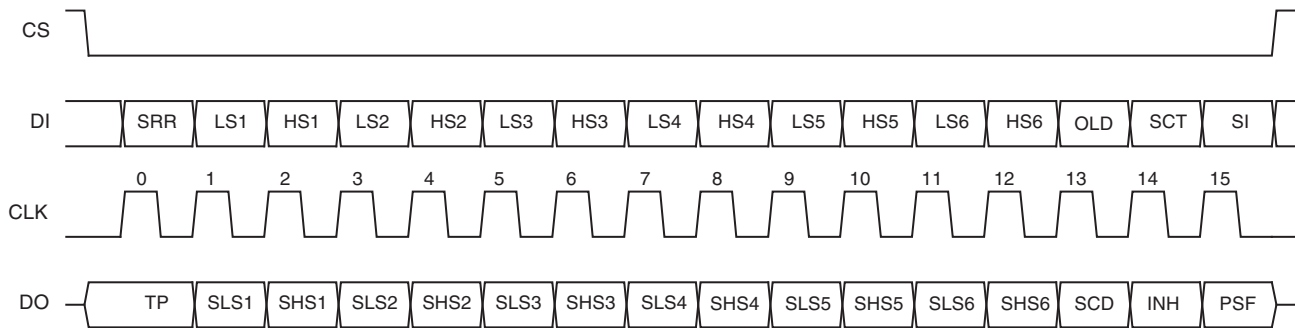

**Table 3-1.** Input Data Protocol

Bit	Input Register	Function
0	SRR	Status register reset (high = reset; the bits PSF, SCD and overtemperature shutdown in the output data register are set to low)
1	LS1	Controls output LS1 (high = switch output LS1 on)
2	HS1	Controls output HS1 (high = switch output HS1 on)
3	LS2	See LS1
4	HS2	See HS1
5	LS3	See LS1
6	HS3	See HS1
7	LS4	See LS1
8	HS4	See HS1
9	LS5	See LS1
10	HS5	See HS1
11	LS6	See LS1
12	HS6	See HS1
13	OLD	Open load detection (low = on)
14	SCT	Programmable time delay for short circuit (shutdown delay high/low = 12ms/1.5ms)
15	SI	Software inhibit; low = standby, high = normal operation (data transfer is not affected by standby function because the digital part is still powered)

**Table 3-2.** Output Data Protocol

Bit	Output (Status) Register	Function
0	TP	Temperature prewarning: high = warning (overtemperature shutdown see remark below)
1	Status LS1	Normal operation: high = output is on, low = output is off Open-load detection: high = open load, low = no open load (correct load condition is detected if the corresponding output is switched off)
2	Status HS1	Normal operation: high = output is on, low = output is off Open-load detection: high = open load, low = no open load (correct load condition is detected if the corresponding output is switched off)
3	Status LS2	Description see LS1
4	Status HS2	Description see HS1
5	Status LS3	Description see LS1
6	Status HS3	Description see HS1
7	Status LS4	Description see LS1
8	Status HS4	Description see HS1
9	Status LS5	Description see LS1
10	Status HS5	Description see HS1
11	Status LS6	Description see LS1
12	Status HS6	Description see HS1
13	SCD	Short circuit detected: set high, when at least one output is switched off by a short circuit condition
14	INH	Inhibit: this bit is controlled by software (bit SI in input register) and hardware inhibit (pin INH). High = standby, low = normal operation
15	PSF	Power supply fail: undervoltage at pin VS detected

Note: Bit 0 to 15 = high: overtemperature shutdown

**Table 3-3.** Status of the Input Register After Power on Reset

Bit 15 (SI)	Bit 14 (SCT)	Bit 13 (OLD)	Bit 12 (HS6)	Bit 11 (LS6)	Bit 10 (HS5)	Bit 9 (LS5)	Bit 8 (HS4)	Bit 7 (LS4)	Bit 6 (HS3)	Bit 5 (LS3)	Bit 4 (HS2)	Bit 3 (LS2)	Bit 2 (HS1)	Bit 1 (LS1)	Bit 0 (SRR)
H	H	H	L	L	L	L	L	L	L	L	L	L	L	L	L

## 3.2 Power-supply Fail

In case of undervoltage at pin VS, an internal timer is started. When during a permanent undervoltage the delay time ( $t_{dUV}$ ) is reached, the power supply fail bit (PSF) in the output register is set and all outputs are disabled. When normal voltage is present again, the outputs are enabled immediately. The PSF bit remains high until it is reset by the SRR bit in the input register.

## 3.3 Open-load Detection

If the open-load detection bit (OLD) is set to low, a pull-up current for each high-side switch and a pull-down current for each low-side switch is turned on (open-load detection current  $I_{HS1-6}$ ,  $I_{LS1-6}$ ). If  $V_{VS} - V_{HS1-6}$  or  $V_{LS1-6}$  is lower than the open-load detection threshold (open-load condition), the corresponding bit of the output in the output register is set to high. Switching on an output stage with OLD bit set to low disables the open load function for this output.

## 3.4 Overtemperature Protection

If the junction temperature exceeds the thermal prewarning threshold,  $T_{jPW}$  set, the temperature prewarning bit (TP) in the output register is set. When the temperature falls below the thermal prewarning threshold,  $T_{jPW}$  reset, the bit TP is reset. The TP bit can be read without transferring a complete 16-bit data word: with CS = high to low, the state of TP appears at pin DO. After the microcontroller has read this information, CS is set high and the data transfer is interrupted without affecting the state of the input and output registers.

If the junction temperature exceeds the thermal shutdown threshold,  $T_{j\text{ switch off}}$ , the outputs are disabled and all bits in the output register are set high. The outputs can be enabled again when the temperature falls below the thermal shutdown threshold,  $T_{j\text{ switch on}}$ , and when a high has been written to the SRR bit in the input register. Thermal prewarning and shutdown threshold have hysteresis.

## 3.5 Short-circuit Protection

The output currents are limited by a current regulator. Current limitation takes place when the overcurrent limitation and shutdown threshold ( $I_{HS1-6}$ ,  $I_{LS1-6}$ ) are reached. Simultaneously, an internal timer is started. The shorted output is disabled when during a permanent short the delay time ( $t_{dSd}$ ) programmed by the short-circuit timer bit (SCT) is reached. Additionally, the short-circuit detection bit (SCD) is set. If the temperature prewarning bit TP in the output register is set during a short, the shorted output is disabled immediately and SCD bit is set. By writing a high to the SRR bit in the input register, the SCD bit is reset and the disabled outputs are enabled.

## 3.6 Inhibit

There are two ways to inhibit the Atmel® ATA6838C:

- Set bit SI in the input register to 0
- Switch pin INH to 0V

In both cases, all output stages are turned off but the serial interface stays active. The output stages can be activated again by bit SI = 1 (when INH = VCC) or by pin INH switched back to VCC (when SI = 1).

## 4. Absolute Maximum Ratings

Stresses beyond those listed under “Absolute Maximum Ratings” may cause permanent damage to the device. This is a stress rating only and functional operation of the device at these or any other conditions beyond those indicated in the operational sections of this specification is not implied. Exposure to absolute maximum rating conditions for extended periods may affect device reliability.

All values refer to GND pins.

Parameters	Pin QFN24	Symbol	Value	Unit
Supply voltage	3, 4	$V_{VS}$	-0.3 to +40	V
Supply voltage $t < 0.5s$ ; $I_S > -2A$	3, 4	$V_{VS}$	-1	V
Supply voltage difference $ V_{S\_pin5(3)} - V_{S\_pin10(4)} $	3, 4	$\Delta V_{VS}$	150	mV
Logic supply voltage	14	$V_{VCC}$	-0.3 to +7	V
Logic input voltage	17-19	$V_{DI}, V_{CLK}, V_{CS}$	-0.3 to $V_{VCC} + 0.3$	V
Logic output voltage	13	$V_{DO}$	-0.3 to $V_{VCC} + 0.3$	V
Input current	12, 17-19	$I_{INH}, I_{DI}, I_{CLK}, I_{CS}$	-10 to +10	mA
Output current	13	$I_{DO}$	-10 to +10	mA
Output current	2, 5, 8, 11, 20, 23	$I_{OUT1}$ to $I_{OUT6}$	Internally limited, see “Output Specification” in <a href="#">Section 7. on page 9</a>	
Output voltage	2, 5, 8, 11, 20, 23	OUT1 to OUT6	-0.3 to +40	V
Junction temperature range		$T_J$	-40 to +150	°C
Storage temperature range		$T_{STG}$	-55 to +150	°C

## 5. Thermal Resistance

**Table 5-1.** QFN24: Depends on the PCB-board

Parameter	Test Conditions	Pin	Symbol	Min.	Typ.	Max.	Unit
Junction pin		16	$R_{thJP}$			< 5	K/W
Junction ambient			$R_{thJA}$			35	K/W



## 6. Operating Range

Parameter	Test Conditions	Pin QFN24	Symbol	Min.	Typ.	Max.	Unit
Supply voltage		3, 4	$V_{VS}$	$V_{UV}^{(1)}$		40	V
Logic supply voltage		14	$V_{VCC}$	4.75		5.25	V
Logic input voltage		12, 17-19	$V_{INH}, V_{DI}, V_{CLK}, V_{CS}$	-0.3		$V_{VCC}$	V
Serial interface clock frequency			$f_{CLK}$			2	MHz
Junction temperature range			$T_j$	-40		+150	°C

## 7. Electrical Characteristics

7.5V <  $V_S$  < 40V; 4.75 <  $V_{CC}$  < 5.25V; INH = High; -40°C <  $T_j$  < 150°C; unless otherwise specified, all values refer to GND pins.

No.	Parameters	Test Conditions	Pin QFN24	Symbol	Min.	Typ.	Max.	Unit	Type*
<b>1 Current Consumption</b>									
1.1	Total quiescent current ( $V_S$ and all outputs to $V_S$ )	$V_S = 33V$ $V_{CC} = 0V$ or $V_{CC} = 5V$ , bit SI = low or $V_{CC} = 5V$ , pin INH = low Output pins to $V_S$ and GND	3, 4	$I_{VS}$			2	$\mu A$	A
1.2	Quiescent current (VCC)	4.75V < $V_{VCC}$ < 5.25V, INH or bit SI = low	14	$I_{VCC}$			20	$\mu A$	A
		4.75V < $V_{VCC}$ < 5.25V, INH or bit SI = low, $T_j = -40^\circ C$	14	$I_{VCC}$			30	$\mu A$	A
1.3	Supply current ( $V_S$ )	$V_{VS} < 28V$ normal operation, all output stages off	3, 4	$I_{VS}$		0.8	1.2	mA	A
1.4	Supply current ( $V_S$ )	$V_{VS} < 28V$ normal operation, all output low stages on, no load	3, 4	$I_{VS}$			10	mA	A
1.5	Supply current ( $V_S$ )	$V_{VS} < 28V$ normal operation, all output high stages on, no load	3, 4	$I_{VS}$			16	mA	A
1.6	Supply current (VCC)	4.75V < $V_{VCC}$ < 5.25V, normal operation	14	$I_{VCC}$			150	$\mu A$	A
1.7	Discharge current ( $V_S$ )	$V_{VS} = 40V$ , INH = low	3, 4	$I_{VS}$			5	mA	A
<b>2 Internal Oscillator Frequency</b>									
2.1	Frequency (time base for delay timers)			$f_{OSC}$	24.3		59	kHz	A
<b>3 Undervoltage Detection, Power-on Reset</b>									
3.1	Power-on reset threshold		14	$V_{VCC}$	2.3	2.7	3.0	V	A
3.2	Power-on reset delay time	After switching on $V_{VCC}$		$t_{dPor}$	30	95	160	$\mu s$	A

\* Type means: A = 100% tested, B = 100% correlation tested, C = Characterized on samples, D = Design parameter

Notes: 1. Delay time between rising edge of input signal at pin CS after data transmission and switch on/off output stages to 90% of final level. Device not in standby for  $t > 1ms$ .

## 7. Electrical Characteristics (Continued)

7.5V < V<sub>S</sub> < 40V; 4.75 < V<sub>CC</sub> < 5.25V; INH = High; -40°C < T<sub>j</sub> < 150°C; unless otherwise specified, all values refer to GND pins.

No.	Parameters	Test Conditions	Pin QFN24	Symbol	Min.	Typ.	Max.	Unit	Type*
3.3	Undervoltage detection threshold		14	V <sub>UV</sub>	5.5		7.0	V	A
3.4	Undervoltage detection hysteresis		14	ΔV <sub>UV</sub>		0.4		V	A
3.5	Undervoltage detection delay			t <sub>dUV</sub>	5		20	ms	A
<b>4</b>	<b>Thermal Prewarning and Shutdown</b>								
4.1	Thermal prewarning			T <sub>jPWset</sub>	120	145	170	°C	B
4.2	Thermal prewarning			T <sub>jPWreset</sub>	105	130	155	°C	B
4.3	Thermal prewarning hysteresis			T <sub>jPW</sub>		15		K	C
4.4	Thermal shutdown			T <sub>j switch off</sub>	150	175	200	°C	B
4.5	Thermal shutdown			T <sub>j switch on</sub>	135	160	185	°C	B
4.6	Thermal shutdown hysteresis			T <sub>j switch off</sub>		15		K	C
4.7	Ratio thermal shutdown/thermal prewarning			T <sub>j switch off/</sub> T <sub>jPW set</sub>	1.05	1.2			C
4.8	Ratio thermal shutdown/thermal prewarning			T <sub>j switch on/</sub> T <sub>jPW reset</sub>	1.05	1.2			C
<b>5</b>	<b>Output Specification (LS1-LS6, HS1-HS6) 7.5V &lt; V<sub>VS</sub> &lt; 40V</b>								
5.1	On resistance	I <sub>Out</sub> = 600mA	2, 5, 8, 11, 20, 23	R <sub>DS OnL</sub>			1.8	Ω	A
5.2	On resistance	I <sub>Out</sub> = -600mA	2, 5, 8, 11, 20, 23	R <sub>DS OnH</sub>			1.8	Ω	A
5.3	High-side output leakage current (total quiescent current see 1.1)	V <sub>Out1-6</sub> = 0V all output stages off	2, 5, 8, 11, 20, 23	I <sub>Out1-6</sub>	-15			μA	A
5.4	Low-side output leakage current (total quiescent current see 1.1)	V <sub>Out1-6</sub> = VS all output stages off	2, 5, 8, 11, 20, 23	I <sub>Out1-6</sub>			120	μA	A
5.5	Inductive shutdown energy		2, 5, 8, 11, 20, 23	W <sub>outx</sub>			15	mJ	D
5.6	Overcurrent limitation and shutdown threshold	V <sub>VS</sub> = 13V	2, 5, 8, 11, 20, 23	I <sub>LS1-6</sub>	950	1250	1710	mA	A
5.7	Overcurrent limitation and shutdown threshold	V <sub>VS</sub> = 13V	2, 5, 8, 11, 20, 23	I <sub>HS1-6</sub>	-1710	-1250	-950	mA	A
5.8	Overcurrent limitation and shutdown threshold	20V < V <sub>VS</sub> < 40V	2, 5, 8, 11, 20, 23	I <sub>LS1-6</sub>	950		2100	mA	C
5.9	Overcurrent limitation and shutdown threshold	20V < V <sub>VS</sub> < 40V	2, 5, 8, 11, 20, 23	I <sub>HS1-6</sub>	-2100		-950	mA	C

\*) Type means: A = 100% tested, B = 100% correlation tested, C = Characterized on samples, D = Design parameter

Notes: 1. Delay time between rising edge of input signal at pin CS after data transmission and switch on/off output stages to 90% of final level. Device not in standby for t > 1ms.

## 7. Electrical Characteristics (Continued)

7.5V < V<sub>S</sub> < 40V; 4.75 < V<sub>CC</sub> < 5.25V; INH = High; -40°C < T<sub>j</sub> < 150°C; unless otherwise specified, all values refer to GND pins.

No.	Parameters	Test Conditions	Pin QFN24	Symbol	Min.	Typ.	Max.	Unit	Type*
5.10	Overcurrent shutdown delay time	Input register bit 14 (SCT) = low V <sub>VS</sub> = 13V		t <sub>dSd</sub>	0.7	1.5	2.1	ms	A
5.11	Overcurrent shutdown delay time	Input register bit 14 (SCT) = High V <sub>VS</sub> = 13V		t <sub>dSd</sub>	7	12	17	ms	A
5.12	High-side open load detection current	Input register bit 13 (OLD) = low, output off	2, 5, 8, 11, 20, 23	I <sub>Out1-6H</sub>	-1.5		-0.4	mA	A
5.13	Low-side open load detection current	Input register bit 13 (OLD) = low, output off	2, 5, 8, 11, 20, 23	I <sub>Out1-6L</sub>	0.4		1.5	mA	A
5.14	Open load detection current ratio		2, 5, 8, 11, 20, 23	I <sub>OLoutLX</sub> / I <sub>OLoutHX</sub>	1.05	1.2	2		
5.15	High-side open load detection voltage	Input register bit 13 (OLD) = low, output off	2, 5, 8, 11, 20, 23	V <sub>Out1-6H</sub>	0.6		2.5	V	A
5.16	Low-side open load detection voltage	Input register bit 13 (OLD) = low, output off	2, 5, 8, 11, 20, 23	V <sub>Out1-6L</sub>	0.6		2	V	A
5.17	High-side output switch on delay <sup>(1)</sup>	V <sub>VS</sub> = 13V R <sub>Load</sub> = 30Ω		t <sub>don</sub>			20	μs	A
5.18	Low-side output switch on delay <sup>(1)</sup>	V <sub>VS</sub> = 13V R <sub>Load</sub> = 30Ω		t <sub>don</sub>			20	μs	A
5.19	High-side output switch off delay <sup>(1)</sup>	V <sub>VS</sub> = 13V R <sub>Load</sub> = 30Ω		t <sub>doff</sub>			20	μs	A
5.20	Low-side output switch off delay <sup>(1)</sup>	V <sub>VS</sub> = 13V R <sub>Load</sub> = 30Ω		t <sub>doff</sub>			3	μs	A
5.21	Dead time between corresponding high- and low-side switches	V <sub>VS</sub> = 13V R <sub>Load</sub> = 30Ω		t <sub>don</sub> - t <sub>doff</sub>	0.7			μs	A
<b>6 Inhibit Input</b>									
6.1	Input voltage low-level threshold		12	V <sub>IL</sub>	0.3 × V <sub>VCC</sub>			V	A
6.2	Input voltage high-level threshold		12	V <sub>IH</sub>			0.7 × V <sub>VCC</sub>	V	A
6.3	Hysteresis of input voltage		12	ΔV <sub>I</sub>	100		700	mV	A
6.4	Pull-down current	V <sub>INH</sub> = V <sub>VCC</sub>		I <sub>PD</sub>	10		80	μA	A

\*) Type means: A = 100% tested, B = 100% correlation tested, C = Characterized on samples, D = Design parameter

Notes: 1. Delay time between rising edge of input signal at pin CS after data transmission and switch on/off output stages to 90% of final level. Device not in standby for t > 1ms.

## 7. Electrical Characteristics (Continued)

7.5V < V<sub>S</sub> < 40V; 4.75 < V<sub>CC</sub> < 5.25V; INH = High; -40°C < T<sub>j</sub> < 150°C; unless otherwise specified, all values refer to GND pins.

No.	Parameters	Test Conditions	Pin QFN24	Symbol	Min.	Typ.	Max.	Unit	Type*
<b>7 Serial Interface: Logic Inputs DI, CLK, CS</b>									
7.1	Input voltage low-level threshold		17-19	V <sub>IL</sub>	0.3 × V <sub>VCC</sub>			V	A
7.2	Input voltage high-level threshold		17-19	V <sub>IH</sub>			0.7 × V <sub>VCC</sub>	V	A
7.3	Hysteresis of input voltage		17-19	ΔV <sub>I</sub>	50		500	mV	A
7.4	Pull-down current pin DI, CLK	V <sub>DI</sub> , V <sub>CLK</sub> = V <sub>VCC</sub>	18, 19	I <sub>PDSI</sub>	2		50	μA	A
7.5	Pull-up current pin CS	V <sub>CS</sub> = 0V	17	I <sub>PUSI</sub>	-50		-2	μA	A
<b>8 Serial Interface: Logic Output DO</b>									
8.1	Output voltage low level	I <sub>OL</sub> = 3mA	13	V <sub>DOl</sub>			0.5	V	A
8.2	Output voltage high level	I <sub>OL</sub> = -1mA	13	V <sub>DOH</sub>	V <sub>VCC</sub> - 0.7V			V	A
8.3	Leakage current (tri-state)	V <sub>CS</sub> = V <sub>VCC</sub> , 0V < V <sub>DO</sub> < V <sub>VCC</sub>	13	I <sub>DO</sub>	-10		10	μA	A

\*) Type means: A = 100% tested, B = 100% correlation tested, C = Characterized on samples, D = Design parameter

Notes: 1. Delay time between rising edge of input signal at pin CS after data transmission and switch on/off output stages to 90% of final level. Device not in standby for t > 1ms.

## 8. Serial Interface: Timing

Parameters	Test Conditions	QFN24	Number in Timing Diagram (Figure 8-1 on page 13)	Symbol	Min.	Typ.	Max.	Unit
DO enable after CS falling edge	C <sub>DO</sub> = 100pF	13	1	t <sub>ENDO</sub>			200	ns
DO disable after CS rising edge	C <sub>DO</sub> = 100pF	13	2	t <sub>DISDO</sub>			200	ns
DO fall time	C <sub>DO</sub> = 100pF	13	-	t <sub>DOF</sub>			100	ns
DO rise time	C <sub>DO</sub> = 100pF	13	-	t <sub>DOR</sub>			100	ns
DO valid time	C <sub>DO</sub> = 100pF	13	10	t <sub>DOVal</sub>			200	ns
CS setup time		17	4	t <sub>CSSethl</sub>	225			ns
CS setup time		17	8	t <sub>CSSeth</sub>	225			ns
CS high time	Input register bit 14 (SCT) = high	17	9	t <sub>CSH</sub>	17			ms
CS high time	Input register bit 14 (SCT) = low	17	9	t <sub>CSH</sub>	2.1			ms
CLK high time		18	5	t <sub>CLKh</sub>	225			ns
CLK low time		18	6	t <sub>CLKl</sub>	225			ns
CLK period time		18	-	t <sub>CLKp</sub>	500			ns
CLK setup time		18	7	t <sub>CLKSethl</sub>	225			ns
CLK setup time		18	3	t <sub>CLKSeth</sub>	225			ns
DI setup time		19	11	t <sub>Dlset</sub>	40			ns
DI hold time		19	12	t <sub>DlHold</sub>	40			ns

**Figure 8-1.** Serial Interface Timing Diagram with Item Numbers

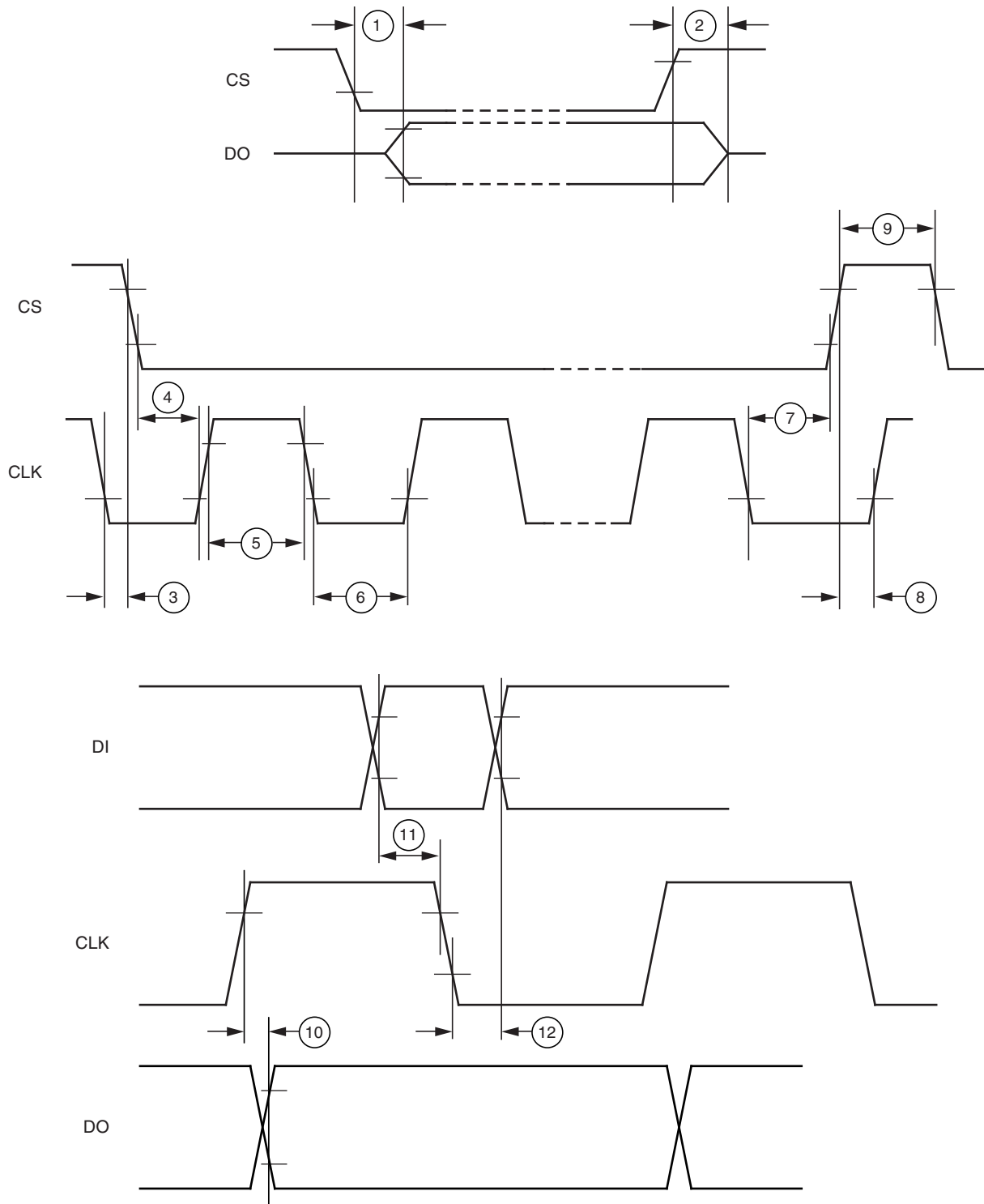

Inputs DI, CLK, CS: High level =  $0.7 \times V_{CC}$ , low level =  $0.2 \times V_{CC}$   
 Output DO: High level =  $0.8 \times V_{CC}$ , low level =  $0.2 \times V_{CC}$

## 9. Noise and Surge Immunity

Parameters	Test Conditions	Value
Conducted interferences	ISO 7637-1	Level 4 <sup>(1)</sup>
Interference suppression	VDE 0879 Part 2	Level 5
ESD (Human Body Model)	ESD S 5.1	4kV
CDM (Charge Device Model)	ESD STM5.3	750V for corner pins (SO package only) 500V all other pins
MM (Machine Model)	ESD STM5.2	200V

Note: 1. Test pulse 5:  $V_{vbmax} = 40V$

## 10. Application Circuit

Figure 10-1. Application Circuit

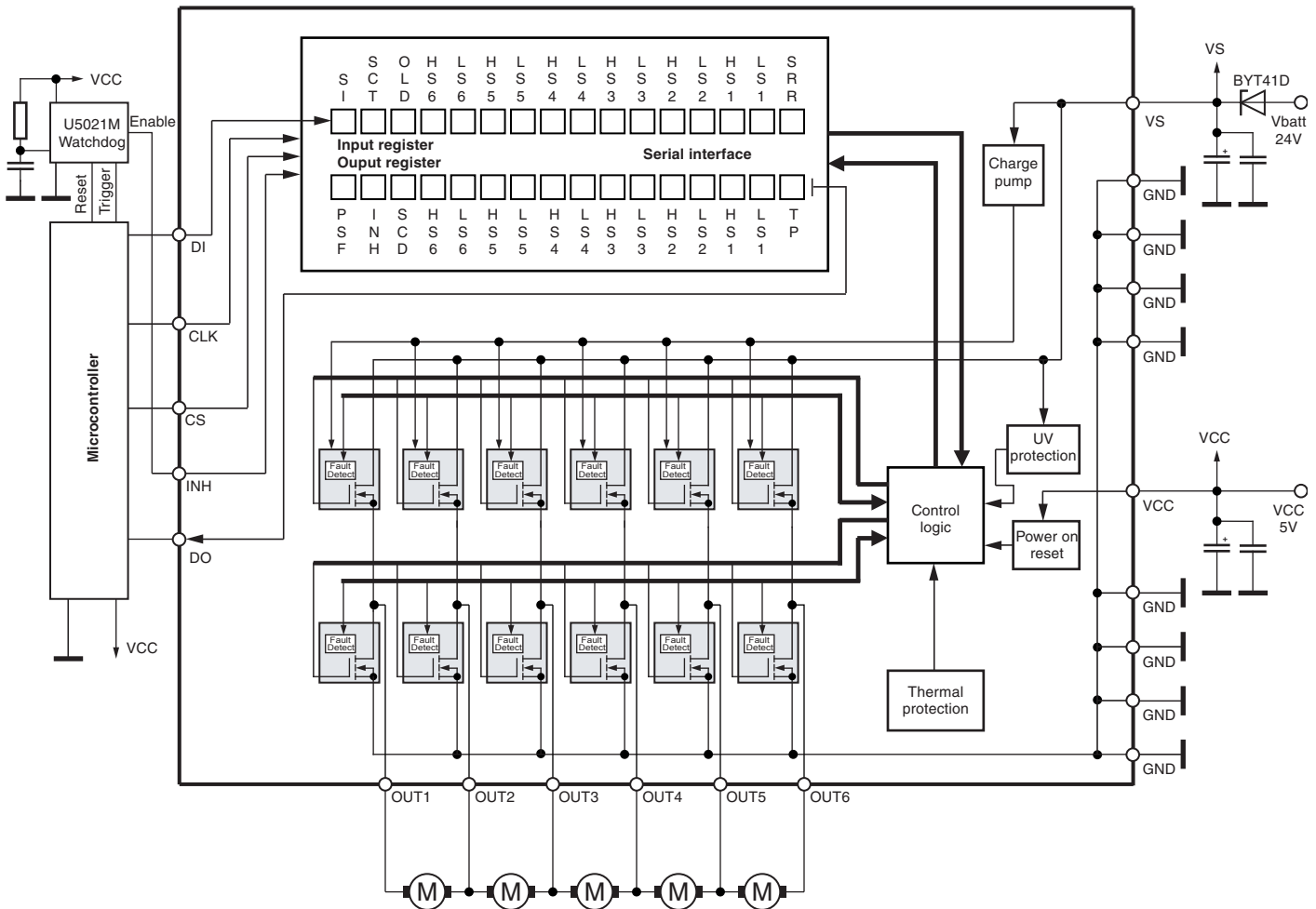

## 10.1 Application Notes

- Connect the blocking capacitors at  $V_{CC}$  and  $V_S$  as close as possible to the power supply and GND pins.
- Recommended value for capacitors at  $V_S$ :  
Electrolytic capacitor  $C > 22\mu\text{F}$  in parallel with a ceramic capacitor  $C = 100\text{nF}$ .  
Value for electrolytic capacitor depends on external loads, conducted interferences and reverse-conducting current IHSX (see [Section 4. "Absolute Maximum Ratings" on page 8](#)).
- Recommended value for capacitors at  $V_{CC}$ :  
Electrolytic capacitor  $C > 10\mu\text{F}$  in parallel with a ceramic capacitor  $C = 100\text{nF}$ .
- To reduce thermal resistance, place cooling areas on the PCB as close as possible to GND pins and to the die paddle in QFN24.
- Only for the QFN24 versions: The sense pins OUTx SENSE can either be left open or can be connected to the adjacent OUTx pin. Never use the sense pins OUTx SENSE as power outputs.

## 11. Ordering Information

Extended Type Number	Package	Remarks
ATA6838C-PXQW	QFN24	Taped and reeled, Pb-free

## 12. Package Information

### 12.1 QFN24

Package: QFN 24 - 5 x 5  
 Exposed pad 3.6 x 3.6  
 (acc. JEDEC OUTLINE No. MO-220)

Dimensions in mm

Not indicated tolerances  $\pm 0.05$

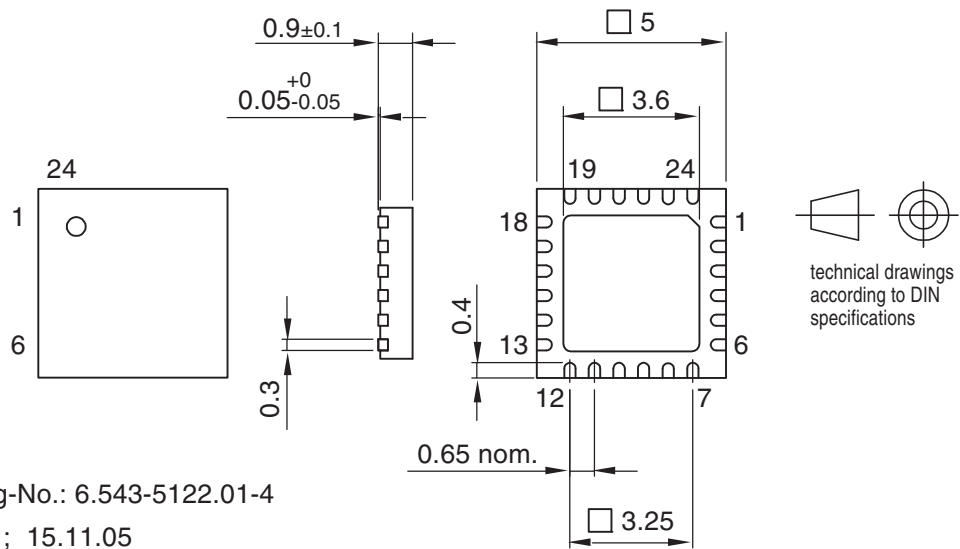

Drawing-No.: 6.543-5122.01-4

Issue: 1; 15.11.05





***Atmel Corporation***

2325 Orchard Parkway  
San Jose, CA 95131  
USA

**Tel:** (+1)(408) 441-0311

**Fax:** (+1)(408) 487-2600

***Atmel Asia Limited***

Unit 01-5 & 16, 19/F  
BEA Tower, Millennium City 5  
418 Kwun Tong Road  
Kwun Tong, Kowloon  
HONG KONG

**Tel:** (+852) 2245-6100

**Fax:** (+852) 2722-1369

***Atmel Munich GmbH***

Business Campus  
Parking 4  
D-85748 Garching b. Munich  
GERMANY

**Tel:** (+49) 89-31970-0

**Fax:** (+49) 89-3194621

***Atmel Japan***

9F, Tonetsu Shinkawa Bldg.  
1-24-8 Shinkawa  
Chuo-ku, Tokyo 104-0033  
JAPAN

**Tel:** (+81) (3) 3523-3551

**Fax:** (+81) (3) 3523-7581

© 2011 Atmel Corporation. All rights reserved. / Rev.: 9237B–AUTO–09/11

Atmel®, Atmel logo and combinations thereof, and others are registered trademarks or trademarks of Atmel Corporation or its subsidiaries. Other terms and product names may be trademarks of others.

Disclaimer: The information in this document is provided in connection with Atmel products. No license, express or implied, by estoppel or otherwise, to any intellectual property right is granted by this document or in connection with the sale of Atmel products. EXCEPT AS SET FORTH IN THE ATMEL TERMS AND CONDITIONS OF SALES LOCATED ON THE ATMEL WEBSITE, ATMEL ASSUMES NO LIABILITY WHATSOEVER AND DISCLAIMS ANY EXPRESS, IMPLIED OR STATUTORY WARRANTY RELATING TO ITS PRODUCTS INCLUDING, BUT NOT LIMITED TO, THE IMPLIED WARRANTY OF MERCHANTABILITY, FITNESS FOR A PARTICULAR PURPOSE, OR NON-INFRINGEMENT. IN NO EVENT SHALL ATMEL BE LIABLE FOR ANY DIRECT, INDIRECT, CONSEQUENTIAL, PUNITIVE, SPECIAL OR INCIDENTAL DAMAGES (INCLUDING, WITHOUT LIMITATION, DAMAGES FOR LOSS AND PROFITS, BUSINESS INTERRUPTION, OR LOSS OF INFORMATION) ARISING OUT OF THE USE OR INABILITY TO USE THIS DOCUMENT, EVEN IF ATMEL HAS BEEN ADVISED OF THE POSSIBILITY OF SUCH DAMAGES. Atmel makes no representations or warranties with respect to the accuracy or completeness of the contents of this document and reserves the right to make changes to specifications and products descriptions at any time without notice. Atmel does not make any commitment to update the information contained herein. Unless specifically provided otherwise, Atmel products are not suitable for, and shall not be used in, automotive applications. Atmel products are not intended, authorized, or warranted for use as components in applications intended to support or sustain life.