

Preliminary Data Sheet

VSC7928

SONET/SDH 3.2Gb/s Laser Diode Driver

Features

- Rise Times Less Than 100ps
- High Speed Operation (Up to 3.2Gb/s NRZ Data)
- Differential or Single-Ended Inputs
- Single Supply
- ECL Compatible Clock and Data Inputs
- Direct Access to Modulation and Bias FETs
- Data Density Monitors
- On-chip Reclocking Register
- On-chip Mux for Clocked or Non-clocked Applications
- On-chip 50Ω Input Termination: Clock and Data
- Enhanced Pinout

Applications

- SONET/SDH @ 622Mb/s, 1.244Gb/s, 2.488Gb/s, and 3.125Gb/s
- Full Speed Fibre Channel (1.062Gb/s)

General Description

The VSC7928 is a single 5V supply, 3.2Gb/s laser diode driver with direct access to the laser modulation and bias FETs. Laser bias and modulation currents are set by external components allowing precision monitoring and setting of the current levels. Data density outputs are provided to allow the user to adjust the laser bias in high unbalanced data applications. Clock and data inputs are differentially terminated to 50Ω.

VSC7928 Block Diagram

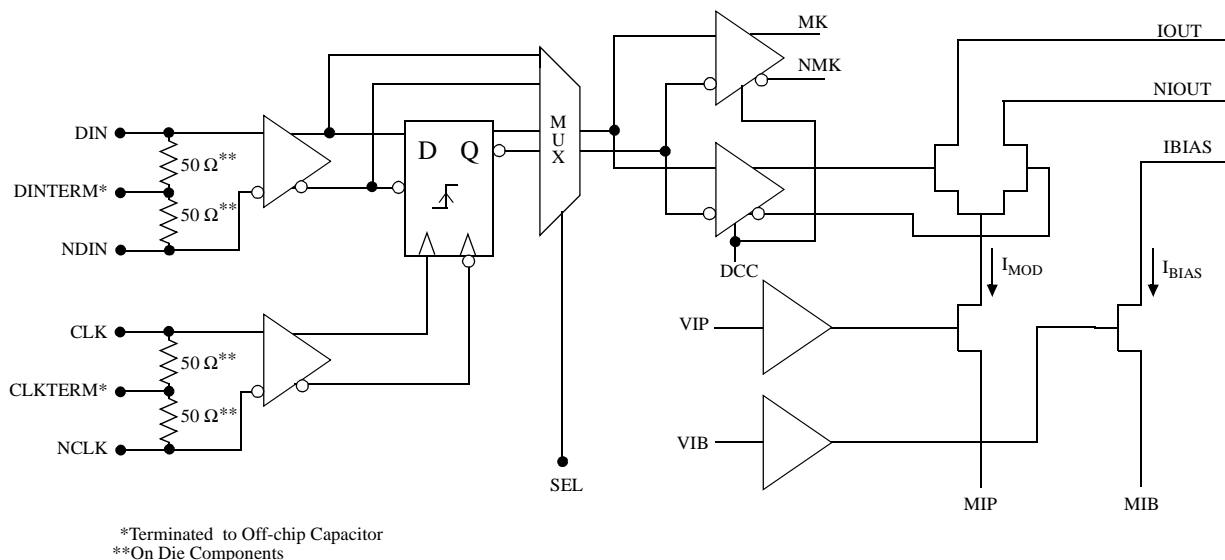

Table 1: Signal Pin Reference

Signal	Type	Level	# Pins	Description
DIN, NDIN	In	ECL	2	Data Input and Data Reference, On-chip 50Ω Termination
MK, NMK	Out	ECL	2	Data Density Differential Outputs
NIOUT	Out	—	1	Laser Modulation Current Output (Complementary)
IOUT	Out	—	1	Laser Modulation Current Output (To Laser Cathode)
VSS	Pwr	Pwr	2	Negative Voltage Rail
GND	Pwr	Pwr	5/6 ⁽¹⁾	Positive Voltage Rail
VIP	In	DC	1	Modulation Gate Node
MIP	In	DC	1	Modulation Source Node
VIB	In	DC	1	Bias Gate Node
MIB	In	DC	1	Bias Source Node
IBIAS	Out	DC	1	Laser Bias Output (To Laser Cathode)
CLK, NCLK	In	ECL	2	Clock Input and Clock Reference, On-chip 50Ω Termination
DINTERM	In	DC	1	Data Reference
CLKTERM	In	DC	1	Clock Reference
DCC	In	DC	1	Duty Cycle Control, Leave Floating
SEL	In	DC	1	Clk/Non-clk Data Select
GND/NC	Pwr	DC	7 ⁽¹⁾	No connection (leave floating or connect to GND)
Total Pins	—	—	24/32*	

NOTE: (1) Applicable to 32-pin TQFP package only.

Table 2: Mux Select Logic Table

SEL	Mode Select
V _{SS}	Clocked Data In
GND	Non-clocked Data In
N/C	Non-clocked Data In

Table 3: Absolute Maximum Ratings

Symbol	Rating	Limit
V _{SS}	Negative Power Supply Voltage	V _{CC} to -6.0V
T _J	Maximum Junction Temperature	-55°C to +125°C
T _{STG}	Storage Temperature	-65°C to +150°C

Table 4: Recommended Operating Conditions

Symbol	Parameter	Min	Typ	Max	Units	Conditions
GND	Positive Voltage Rail	—	0	—	V	
VSS	Negative Voltage Rail	-5.5	-5.2	-4.9	V	
T _{Cl}	Operational Temperature ⁽¹⁾	-40	—	85 ⁽²⁾	°C	Power dissipation = 1.3W
T _J	Junction Temperature	—	—	125	°C	

NOTES: (1) Lower limit of specification is ambient temperature and upper limit is case temperature. (2) See section "Calculation of the Maximum Case Temperature" for detailed maximum temperature calculations.

Preliminary Data Sheet

VSC7928

SONET/SDH 3.2Gb/s Laser Diode Driver

Table 5: High Speed Inputs and ECL Outputs

Symbol	Parameter	Min	Typ	Max	Units	Conditions
V _{IN}	Single-ended Input Voltage Swing	300	—	1500	mVp-p	V _{CM} = -2.0V
V _{CM}	Differential Input Common Mode Range	-2.3	—	-1.3	V	V _{SS} = -5.2V
V _{OH}	ECL Output High Voltage	-1200	—	—	mV	50Ω to -2.0V
V _{OL}	ECL Output Low Voltage	—	—	-1600	mV	50Ω to -2.0V
V _{IN}	On-Chip Terminations	35	—	65	Ω	

Table 6: Power Dissipation

Symbol	Parameter	Min	Typ	Max	Units	Conditions
I _{VSS}	Power Supply Current (VSS)	—	80	120	mA	V _{SS} = -5.5V, I _{MOD} = I _{BIAS} = 0mA, MK/NMK open circuit
P _D	Total Power Dissipation	—	—	700	mW	V _{SS} = -5.5V, I _{MOD} = I _{BIAS} = 0mA, R _{LOAD} = 25Ω to GND, MK/NMK terminated 50Ω to -2V

Table 7: Laser Driver DC Electrical Specifications

Symbol	Parameter	Min	Typ	Max	Units	Conditions
I _{BIAS}	Programmable Laser Bias Current	2	—	100	mA	
I _{MOD}	Programmable Modulation Current	2	—	100	mA	
V _{IB}	Laser Bias Control Voltage	—	—	V _{SS} + 2.1	V	I _{BIAS} = 50mA
V _{IP}	Laser Modulation Control Voltage	—	—	V _{SS} + 2.1	V	I _{MOD} = 60mA
V _{OCM}	Output Voltage Compliance	—	GND - 3V	—	V	V _{SS} = -5.2V

Table 8: Laser Driver AC Electrical Specifications

Symbol	Parameter	Min	Typ	Max	Units	Conditions
t _R , t _F	Output Rise and Fall Times	—	—	100	ps	25Ω load, 20%-80%, 20mA < I _{MOD} < 60mA, I _{BIAS} = 60mA
t _{SU}	Data to Clock Setup Time	—	50	90	ps	—
t _H	Hold Time	20	50	—	ps	—

Figure 1: On-Chip Data and Clock Input Configuration

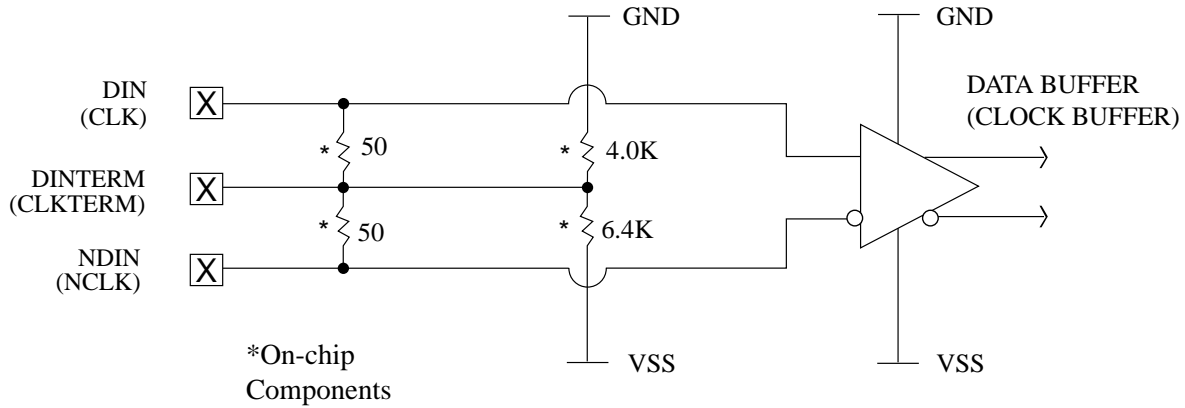

DINTERM to -2.0V for Differential ECL Inputs

Figure 2: Single-Ended Operation

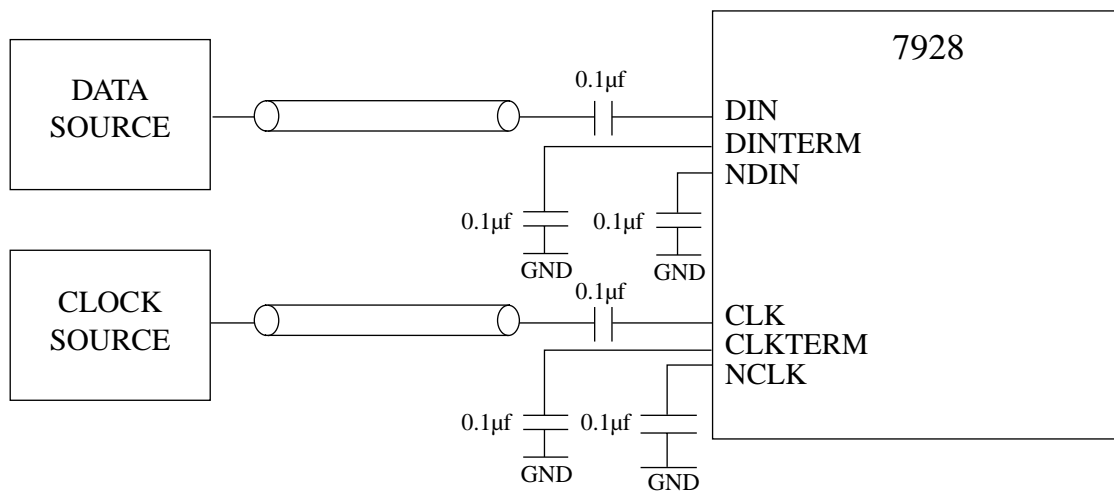

Preliminary Data Sheet
VSC7928

SONET/SDH 3.2Gb/s Laser Diode Driver

Figure 3: Single-Ended AC-Coupled

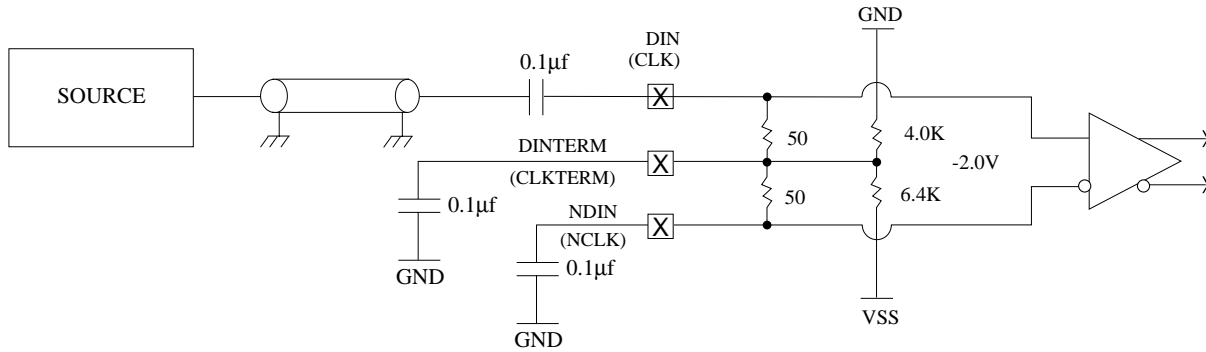

Figure 4: Differential AC-Coupled

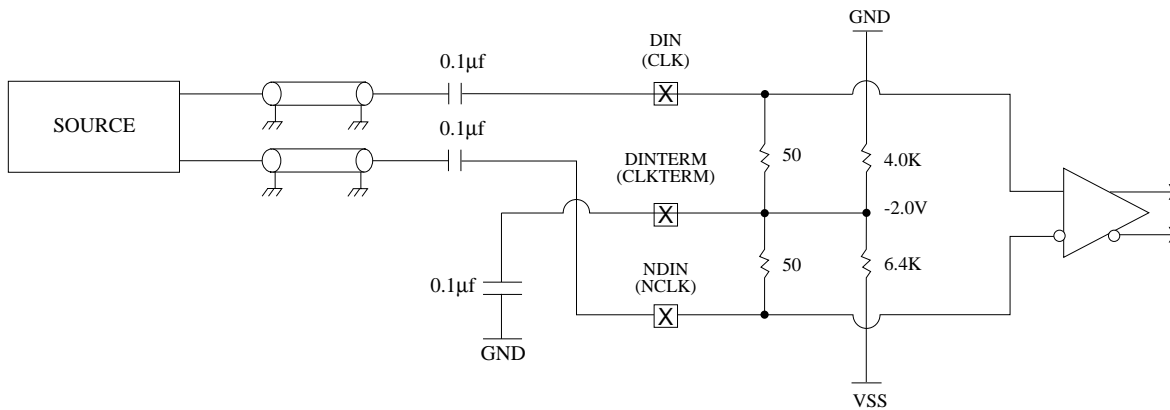

Figure 5: Differential DC-Coupled

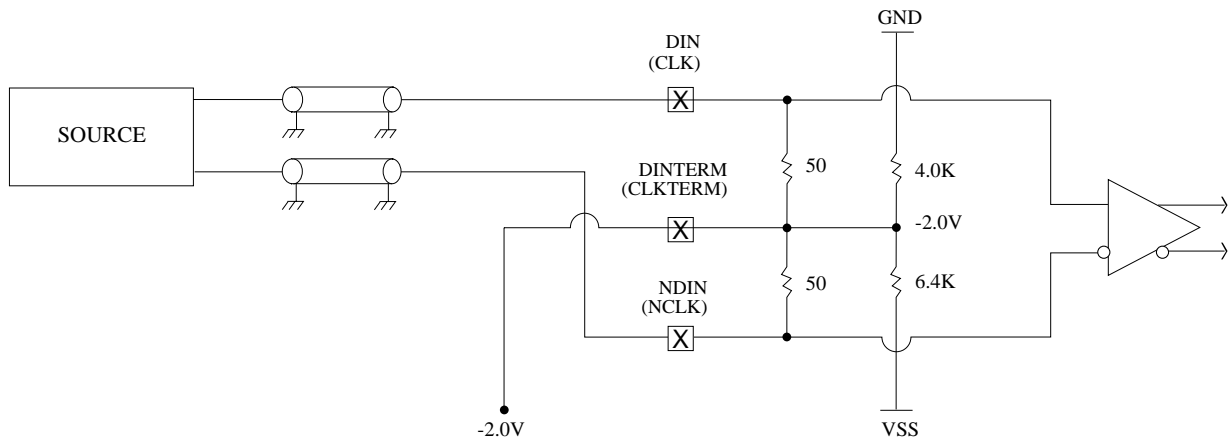
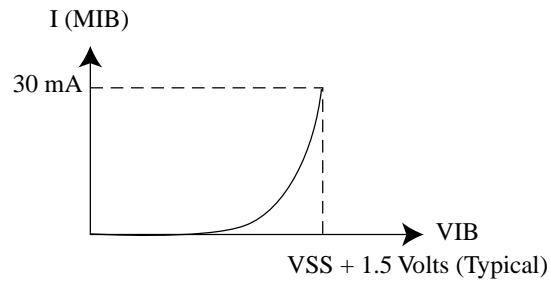
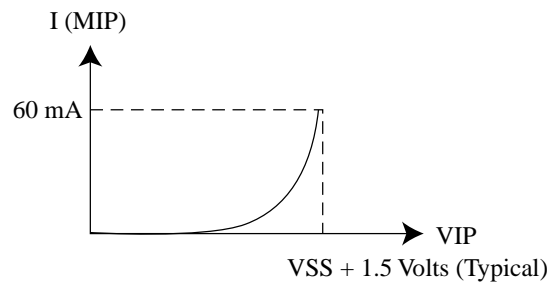

Figure 6: Control Signals VIP and VIB



Typical Bias Current v.s. Bias Voltage



Typical Modulation Current v.s. Modulation Voltage

Figure 7: Simplified Output Structure

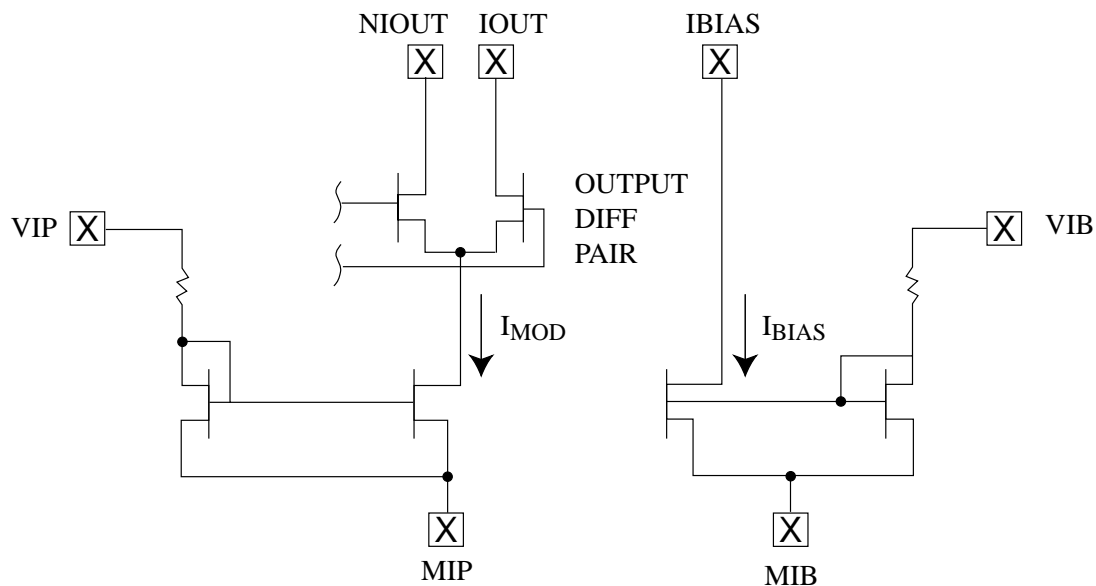

Preliminary Data Sheet

VSC7928

SONET/SDH 3.2Gb/s Laser Diode Driver

Figure 8: Pad Assignments for VSC7928 Die

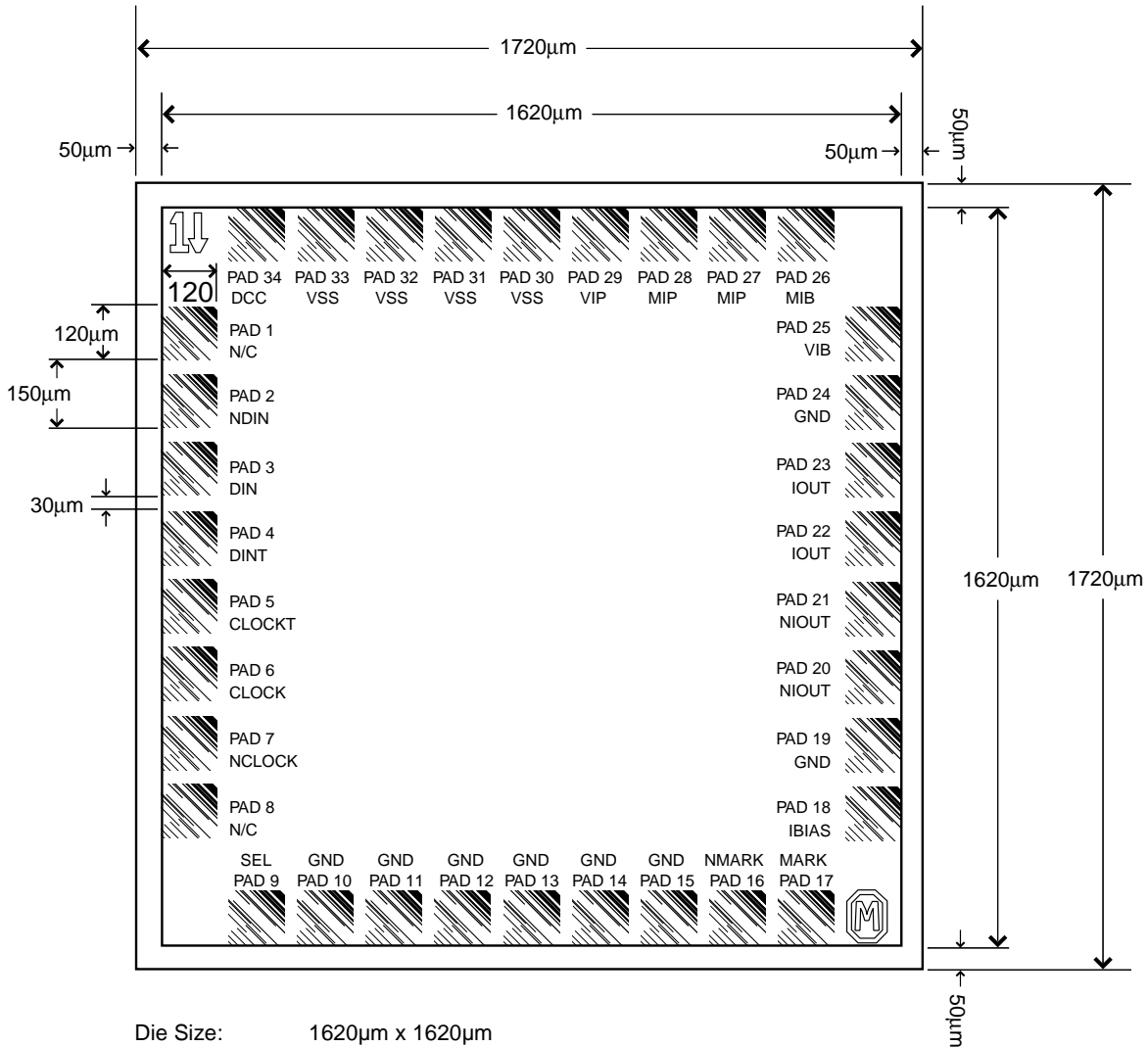

Die Size: 1620µm x 1620µm
 Actual Die Size: 1720µm x 1720µm (after the die are cut up)
 Pad Size: 120µm x 120µm
 Pad Pitch: 150µm
 Space Between Pads: 30µm

Package Information - 32 Pin Plastic TQFP Package

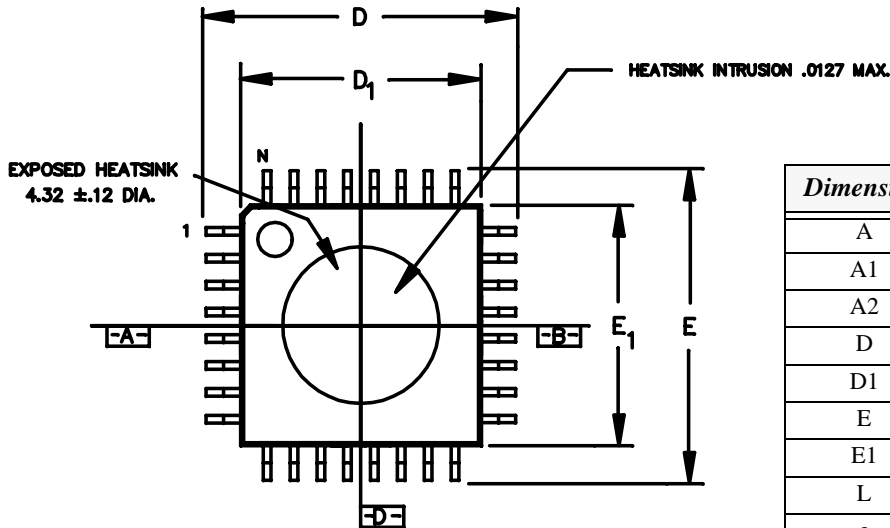

Dimension	mm	Tolerance
A	1.60	MAX
A1	.10	±.05
A2	1.40	±.05
D	9.00	±.20
D1	7.00	±.10
E	9.00	±.20
E1	7.00	±.10
L	.60	+ .15/- .10
e	.80	BASIC
b	.35	±.05
θ	0° - 7°	
ddd	.20	MAX
ccc	.10	MAX

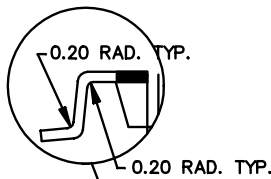
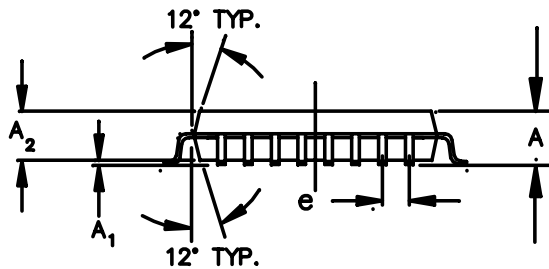

Note: Package lid and bottom heat spreader are electrically connected to GND within the package.

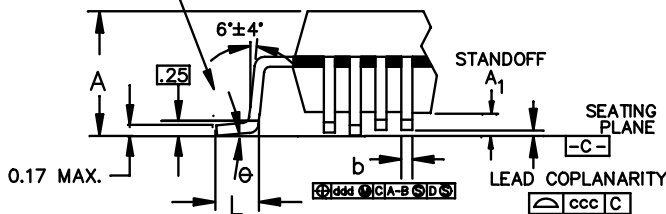

- NOTES: 1) ALL DIMENSIONS IN MM.
 2) DIMENSIONS SHOWN ARE NOMINAL WITH TOL. AS INDICATED
 3) L/F: ETEC 64T COPPER OR EQUIVALENT, 0.127 MM (.005") THICK.
 4) FOOT LENGTH "L" IS MEASURED AT GAGE PLANE, AT 0.25 ABOVE THE SEATING PLANE.

Preliminary Data Sheet
VSC7928

SONET/SDH 3.2Gb/s Laser Diode Driver

32-Pin Plastic Package Pin Designation

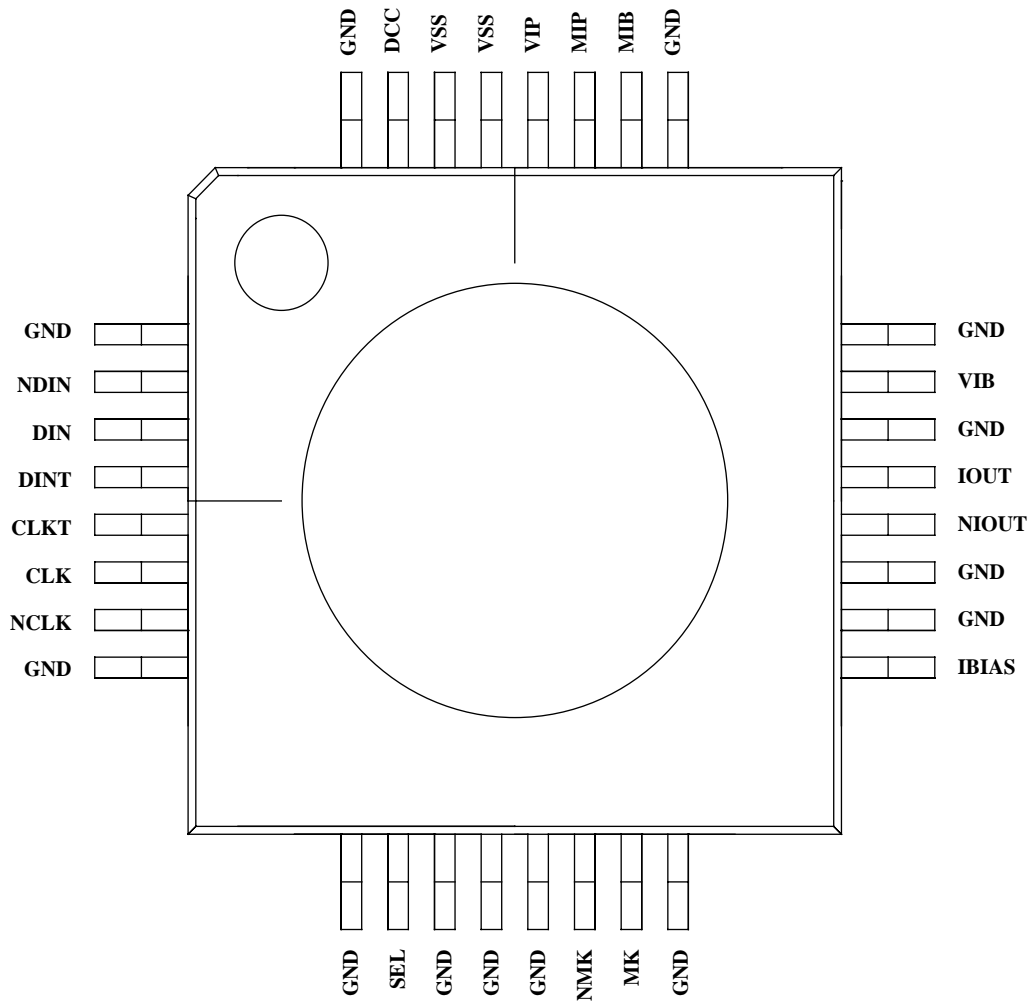

Ordering Information

The order number for this product is formed by a combination of the device number, and package style.

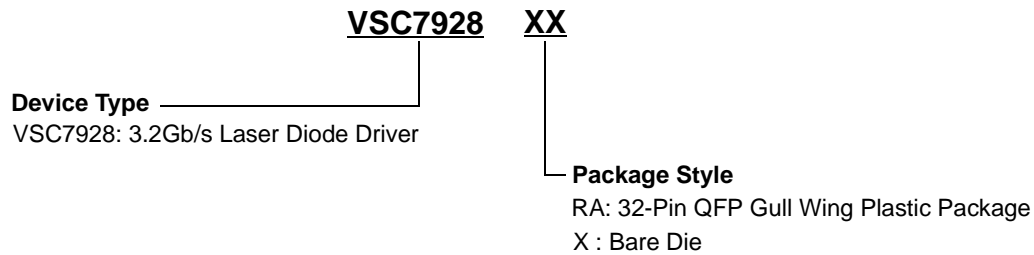

Notice

Vitesse Semiconductor Corporation (“Vitesse”) provides this document for informational purposes only. This document contains pre-production information about Vitesse products in their concept, development and/or testing phase. All information in this document, including descriptions of features, functions, performance, technical specifications and availability, is subject to change without notice at any time. Nothing contained in this document shall be construed as extending any warranty or promise, express or implied, that any Vitesse product will be available as described or will be suitable for or will accomplish any particular task.

Vitesse products are not intended for use in life support appliances, devices or systems. Use of a Vitesse product in such applications without written consent is prohibited.