

LMH6521

High Performance Dual DVGA

General Description

The LMH6521 contains two high performance, digitally controlled variable gain amplifiers (DVGA).

Both channels of the LMH6521 have an independent, digitally controlled attenuator followed by a high linearity, differential output amplifier. Each block has been optimized for low distortion and maximum system design flexibility. Each channel has a high speed power down mode.

The internal digitally controlled attenuator provides precise 0.5dB gain steps over a 31.5dB range. Serial and parallel programming options are provided. Serial mode programming utilizes the SPI™ interface. A Pulse mode is also offered where simple up or down commands can change the gain one step at a time.

The output amplifier has a differential output allowing 10V_{PPD} signal swings on a single 5V supply. The low impedance output provides maximum flexibility when driving filters or analog to digital converters.

Features

- OIP3 of 48.5 dBm at 200 MHz
- Maximum voltage gain of 26 dB
- Gain range of 31.5 dB with 0.5dB step size
- Channel Gain Matching of ±0.04 dB
- Noise figure of 7.3 dB at maximum gain
- -3 dB bandwidth of 1200 MHz
- Low power dissipation
- Independent channel power down
- Three gain control modes:
 - Parallel interface
 - Serial interface (SPI)
 - Pulse mode interface
- Temperature Range -40°C to +85°C
- Thermally enhanced, 32-Pin LLP package

Applications

- Cellular base stations
- Wideband and narrowband IF sampling receivers
- Wideband direct conversion
- Digital pre-distortion
- ADC driver

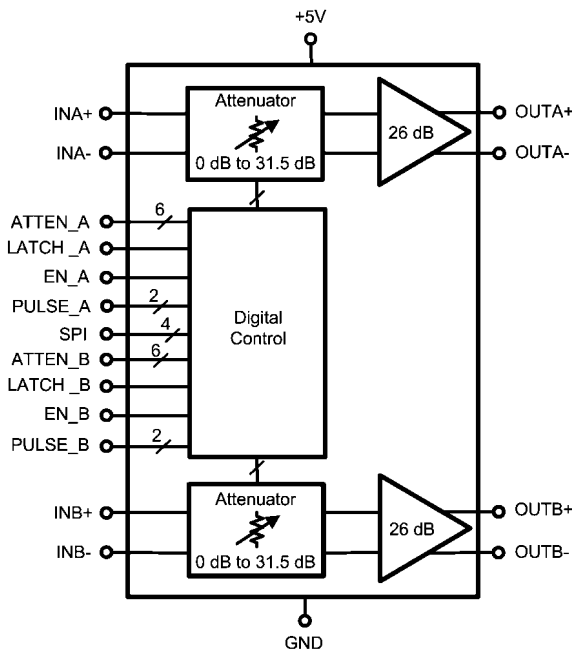

LMH6521 Block Diagram

30120102

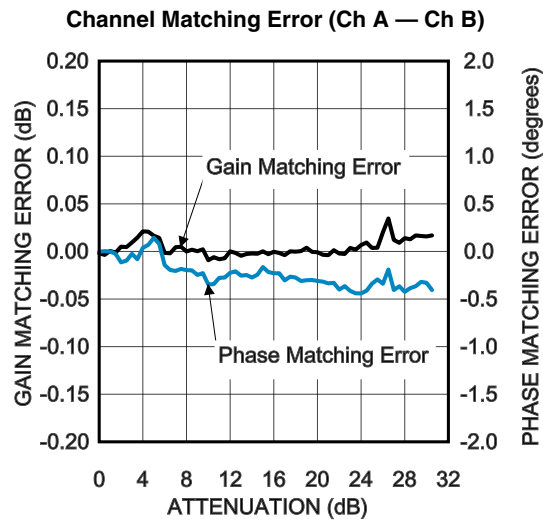

30120180

SPI™ is a trademark of Motorola, Inc.
TRI-STATE® is a registered trademark of National Semiconductor Corporation.

Table of Contents

General Description	1
Features	1
Applications	1
Absolute Maximum Ratings	3
Operating Ratings (<i>Note 1</i>)	3
Connection Diagram	5
Ordering Information	5
Typical Performance Characteristics	8
Application Information	12
Introduction	12
BASIC CONNECTIONS	12
INPUT CHARACTERISTICS	13
OUTPUT CHARACTERISTICS	13
OUTPUT CONNECTIONS	13
DIGITAL CONTROL	13
PARALLEL MODE (MOD1= 1, MOD0 = 1)	14
SERIAL MODE — SPI™ COMPATIBLE INTERFACE (MOD1= 1, MOD0 = 0)	14
PULSE MODE (MOD1= 0, MOD0 = 1)	17
THERMAL MANAGEMENT	17
INTERFACE TO ADC	17
ADC Noise Filter	18
POWER SUPPLIES	18
COMPATIBLE HIGH SPEED ANALOG TO DIGITAL CONVERTERS	19
Physical Dimensions	20

Absolute Maximum Ratings *(Note 1)*

If Military/Aerospace specified devices are required, please contact the National Semiconductor Sales Office/Distributors for availability and specifications.

ESD Tolerance *(Note 2)*

Human Body Model	2 kV
Machine Model	200V
Charged Device Model	750V
Positive Supply Voltage (Pin 14, 27)	-0.6V to 5.5V
Differential Voltage between Any Two Grounds	<200 mV
Analog Input Voltage Range	-0.6V to V+
Digital Input Voltage Range	-0.6V to 5.5V
Junction Temperature	+150°C

Storage Temperature Range	-65°C to +150°C
Soldering Information	
Infrared or Convection (30 sec)	260°C

Operating Ratings *(Note 1)*

Supply Voltage (Pin 14 & 27)	4.75V to 5.25V
Differential Voltage Between Any Two Grounds	<10 mV
Analog Input Voltage Range, AC Coupled	0V to V+
Ambient Temperature Range <i>(Note 3)</i>	-40°C to +85°C
Package Thermal Resistance (θ_{JA})	45°C/W

5V Electrical Characteristics *(Note 4)*

The following specifications apply for single supply with $V_+ = 5V$, Differential $V_{OUT} = 4V_{PP}$, $R_L = 200\Omega$, $T_A = 25^\circ C$, $f_{in} = 200$ MHz, and Maximum Gain (0 attenuation). Boldface limits apply at temperature extremes.

Symbol	Parameter	Conditions	Min <i>(Note 6)</i>	Typ <i>(Note 5)</i>	Max <i>(Note 6)</i>	Units
Dynamic Performance						
SSBW	3 dB Small Signal Bandwidth			1200		MHz
	Output Noise Voltage	At amplifier output with $R_{SOURCE} = 200\Omega$		33		nV/ \sqrt{Hz}
	Noise Figure			7.3		dB
OIP3	Output 3rd-Order Intercept Point	f=100MHz, $P_O = +4dBm$ per tone		56		dBm
		f=200MHz, $P_O = +4dBm$ per tone		48.5		
		f=250MHz, $P_O = +4dBm$ per tone		46.5		
OIP2	Output 2nd-Order Intercept Point	f=100MHz, $P_O = +4dBm$ per tone		92		dBm
		f=200MHz, $P_O = +4dBm$ per tone		80		
		f=250MHz, $P_O = +4dBm$ per tone		73		
HD2	2nd Harmonic Distortion	f=200MHz, $P_O = +6dBm$		-84		dBc
HD3	3rd Harmonic Distortion	f=200MHz, $P_O = +6dBm$		-83		dBc
P1dB	1dB Compression Point			17		dBm
Analog I/O						
	Input Resistance	Differential		200		Ω
	Input Common Mode Voltage	Self Biased (AC coupled)		2.5		V
	Input Common Mode Voltage Range	Externally Driven (DC coupled)		2-3		V
	Maximum Input Voltage Swing	Differential		11		V_{PPD}
	Output Resistance	Differential		20		Ω
	Maximum Differential Output Voltage Swing	Differential		10		V_{PPD}
CMRR	Common Mode Rejection Ratio	At DC, $V_{ID} = 0V$, $V_{CM} = 2.5 \pm 0.5V$		80		dB
PSRR	Power Supply Rejection Ratio	At DC, $V_+ = 5 \pm 0.5V$, $V_{IN} = 2.5V$		77		dB
	Channel to Channel Isolation	f = 200 MHz, min. attenuation setting		73		dB
Gain Parameters						
	Maximum Voltage Gain	Gain Code 000000 (min. attenuation), $A_v = V_O / V_{IN}$		26		dB
	Minimum Voltage Gain	Gain Code 111111 (max. attenuation), $A_v = V_O / V_{IN}$		-5.5		dB

Symbol	Parameter	Conditions	Min (Note 6)	Typ (Note 5)	Max (Note 6)	Units
	Gain Accuracy			1		%
	Gain Step Size			0.5		dB
	Channel Gain Matching	ChA - ChB, any gain setting		±0.04		dB
	Channel Phase Matching			±0.45		degrees
	Cumulative Gain Error	0 to 12 dB attenuation setting		±0.1		dB
		0 to 24 dB attenuation setting		±0.3		dB
		0 to 31 dB attenuation setting		±0.5		dB
	Cumulative Phase Shift	0 to 12 dB attenuation setting		±0.6		degrees
		0 to 24 dB attenuation setting		±5.3		degrees
		0 to 31 dB attenuation setting		±16.5		degrees
	Gain Step Switching Time			15		ns
	Gain Temperature Sensitivity	0 attenuation setting		2.7		mdB/°C
Power Requirements						
VCC	Supply Voltage		4.75	5.0	5.25	V
ICC	Supply Current	Both Channels Enabled		225	245	mA
ICC	Disabled Supply Current	Both Channels		35		mA
All Digital Inputs						
	Logic Compatibility	TTL, 2.5V CMOS, 3.3V CMOS				
VIL	Logic Input Low Voltage			0.5		V
VIH	Logic Input High Voltage			1.8		V
I _{IH}	Logic Input High Input Current	Digital Input Voltage = 5V		200		μA
I _{IL}	Logic Input Low Input Current	Digital Input Voltage = 0V		-60		μA
Parallel and Pulse Mode Timing						
t _{GS}	Setup Time			3		ns
t _{GH}	Hold Time			3		ns
t _{LP}	Latch Low Pulse Width			7		ns
t _{PG}	Pulse Gap between Pulses			20		ns
t _{PW}	Minimum Pulse Width	Pulse Mode		15		ns
t _{RW}	Reset Width			10		ns
Serial Mode Timing and AC Characteristics						
SPI Compatible						
f _{SCLK}	Max Serial Clock Frequency			50		MHz
t _{PH}	SCLK High State Duty Cycle	% of SCLK Period		50		%
t _{PL}	SCLK Low State Duty Cycle	% of SCLK Period		50		%
t _{SU}	Serial Data In Setup Time			2		ns
t _H	Serial Data In Hold Time			2		ns
t _{OZD}	Serial Data Out TRI-STATE-to-Driven Time	Referenced to Negative edge of SCLK		10		ns
t _{OD}	Serial Data Out Output Delay Time	Referenced to Negative edge of SCLK		10		ns
t _{CSS}	Serial Chip Select Setup Time	Referenced to Positive edge of SCLK		5		ns

Note 1: Absolute Maximum Ratings indicate limits beyond which damage to the device may occur. Operating Ratings indicate conditions for which the device is intended to be functional, but specific performance is not guaranteed. For guaranteed specifications, see the Electrical Characteristics tables.

Note 2: Human Body Model, applicable std. MIL-STD-883, Method 3015.7. Machine Model, applicable std. JESD22-A115-A (ESD MM std. of JEDEC) Field-Induced Charge-Device Model, applicable std. JESD22-C101-C (ESD FICDM std. of JEDEC).

Note 3: The maximum power dissipation is a function of $T_{J(MAX)}$, θ_{JA} . The maximum allowable power dissipation at any ambient temperature is $P_D = (T_{J(MAX)} - T_A) / \theta_{JA}$. All numbers apply for packages soldered directly onto a PC Board.

Note 4: Electrical Table values apply only for factory testing conditions at the temperature indicated. No guarantee of parametric performance is indicated in the electrical tables under conditions different than those tested

Note 5: Typical values represent the most likely parametric norm as determined at the time of characterization. Actual typical values may vary over time and will also depend on the application and configuration. The typical values are not tested and are not guaranteed on shipped production material.

Note 6: Limits are 100% production tested at 25°C. Limits over the operating temperature range are guaranteed through correlation using Statistical Quality Control (SQC) methods.

Note 7: Negative input current implies current flowing out of the device.

Note 8: Drift determined by dividing the change in parameter at temperature extremes by the total temperature change.

Connection Diagram

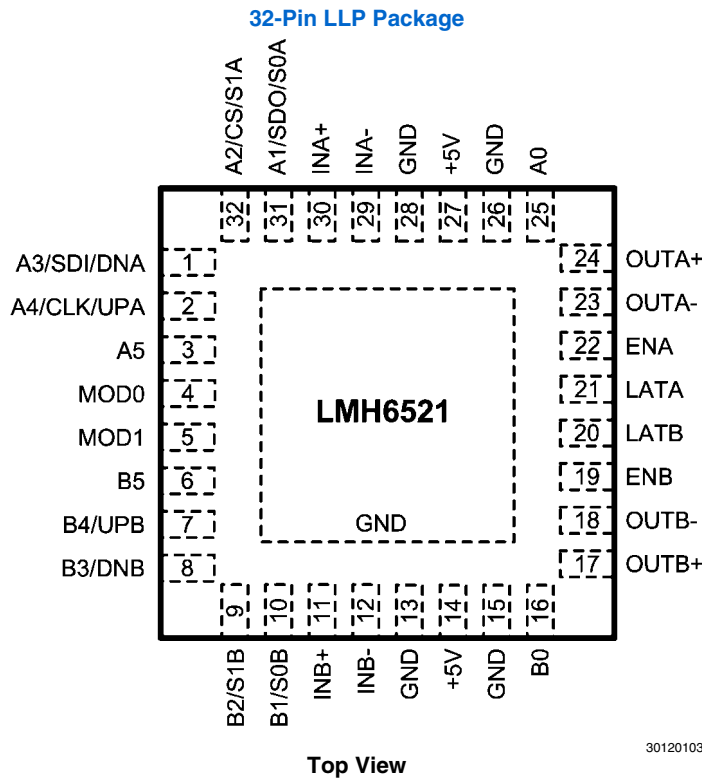

Ordering Information

Package	Part Number	Package Marking	Transport Media	NSC Drawing
32-Pin LLP	LMH6521SQ	L6521SQ	1k Units Tape and Reel	SQA32A
	LMH6521SQE		250 Units Tape and Reel	
	LMH6521SQX		4.5k Units Tape and Reel	

Pin Descriptions

Pin Number	Symbol	Description
Analog I/O		
30, 11	INA+, INB+	Amplifier non—inverting input. Internally biased to mid supply. Input voltage should not exceed V+ or go below GND by more than 0.5V.
29, 12	INA-, INB-	Amplifier inverting input. Internally biased to mid supply. Input voltage should not exceed V+ or go below GND by more than 0.5V.
24, 17	OUTA+, OUTB+	Amplifier non—inverting output. Externally biased to 0V.
23, 18	OUTA-, OUTB-	Amplifier inverting output. Externally biased to 0V.
Power		
13, 15, 26, 28, center pad	GND	Ground pins. Connect to low impedance ground plane. All pin voltages are specified with respect to the voltage on these pins. The exposed thermal pad is internally bonded to the ground pins.
14, 27	+5V	Power supply pins. Valid power supply range is 4.75V to 5.25V.
Common Control Pins		
4, 5	MOD0, MOD1	Digital Mode control pins. These pins float to the logic hi state if left unconnected. See applications section for Mode settings.
22, 19	ENA, ENB	Enable pins. Logic 1 = enabled state. See application section for operation in serial mode.
Digital Inputs Parallel Mode (MOD1 = 1, MOD0 = 1)		
25, 16	A0, B0	Attenuation bit zero = 0.5dB step. Gain steps down from maximum gain (000000 = Maximum Gain).
31, 10	A1, B1	Attenuation bit one = 1dB step.
32, 9	A2, B2	Attenuation bit two = 2dB step.
1, 8	A3, B3	Attenuation bit three = 4dB step.
2, 7	A4, B4	Attenuation bit four = 8dB step.
3, 6	A5, B5	Attenuation bit five = 16dB step.
21, 20	LATA, LATB	Latch pins. Logic zero = active, logic 1 = latched. Gain will not change once latch is high. Connect to ground if the latch function is not desired.
Digital Inputs Serial Mode (MOD1 = 1, MOD0 = 0) SPI compatible		
2	CLK	Serial Clock
1	SDI	Serial Data In. See application section for more details.
32	CSb	Serial Chip Select (Active Low).
31	SDO	Serial Data Out.
3, 4, 6, 7, 8, 9, 10, 16, 20, 21, 25	GND	Pins unused in Serial Mode, connect to DC ground.
Digital Inputs Pulse Mode (MOD1 = 0, MOD0 = 1)		
2, 7	UPA, UPB	Up pulse pin. A logic 0 pulse will increase gain one step.
1, 8	DNA, DNB	Down pulse pin. A logic 0 pulse will decrease gain one step.
1 & 2 or 7 & 8		Pulsing both pins together will reset the gain to maximum gain.
31, 32	S0A, S1A	Step size zero and step size 1. (0,0) = 0.5dB; (0, 1)= 1dB; (1,0) = 2dB, and (1, 1)= 6dB.
10, 9	S0B, S1B	Step size zero and step size 1. (0,0) = 0.5dB; (0, 1)= 1dB; (1,0) = 2dB, and (1, 1)= 6dB.
3, 5, 6, 16, 25	GND	Pins unused in Pulse Mode, connect to DC ground.

Digital Control Mode Pin Functions

Pin Number	Parallel Mode	Serial Mode	Pulse Mode
1	A3	SDI	DNA
2	A4	CLK	UPA
3	A5	NC	GND
4 (MOD0)	LOGIC HIGH (MOD0=1)	LOGIC LOW (MOD0=0)	LOGIC HIGH (MOD0=1)
5 (MOD1)	LOGIC HIGH (MOD1=1)	LOGIC HIGH (MOD1=1)	LOGIC LOW (MOD1=0)
6	B5	GND	GND
7	B4	NC	UPB
8	B3	NC	DNB
9	B2	NC	S1B
10	B1	NC	S0B
11		INB+	
12		INB-	
13		GND	
14		+5V	
15		GND	
16	B0	GND	GND
17		OUTB+	
18		OUTB-	
19		ENB	
20	LATB	GND	GND
21	LATA	GND	GND
22		ENA	
23		OUTA-	
24		OUTA+	
25	A0	NC	GND
26		GND	
27		+5V	
28		GND	
29		INA-	
30		INA+	
31	A1	SDO	S0A
32	A2	CS	S1A

Typical Performance Characteristics

V+ = 5V, Differential V_{OUT} = 4V_{pp}, R_L = 200Ω, T_A = 25 °C, f_{in} = 200 MHz, and Maximum Gain (0 Attenuation)

Frequency Response 2dB Gain Steps

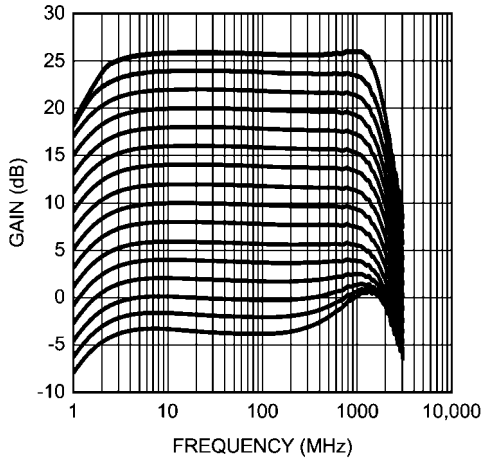

30120174

Gain Flatness vs. Temperature

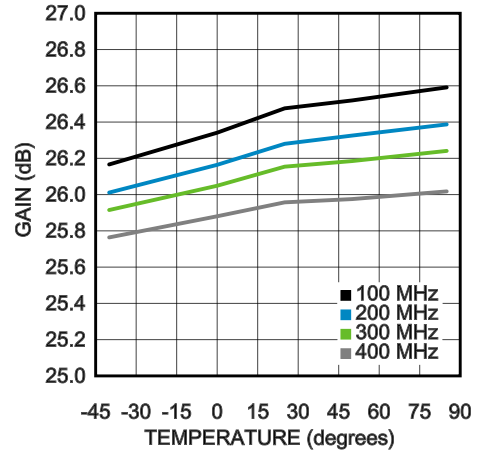

30120197

OIP3 vs. Frequency

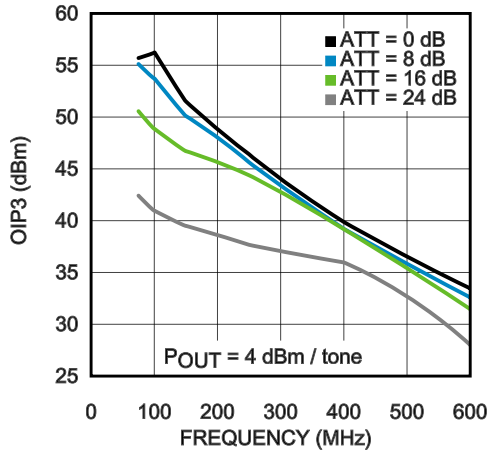

30120179

OIP3 vs. Temperature

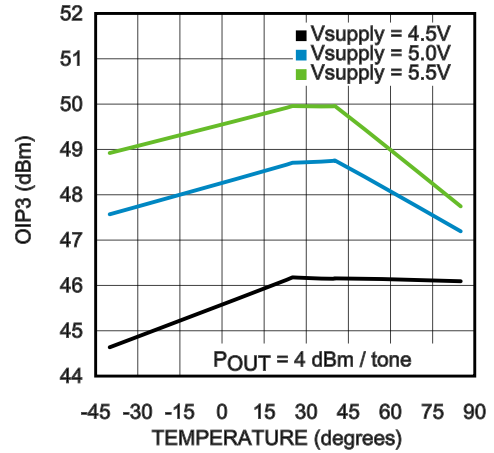

30120176

OIP3 vs. Pout

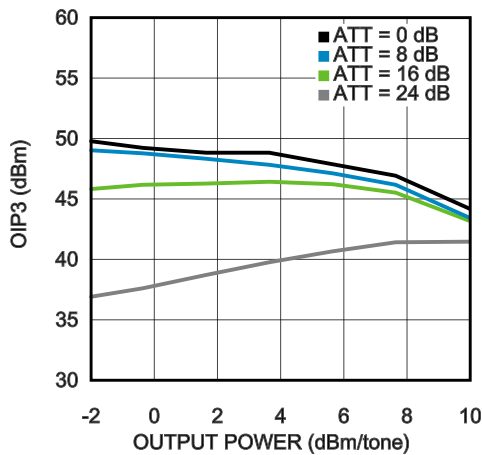

30120177

Third Order Intermodulation Products vs. Frequency

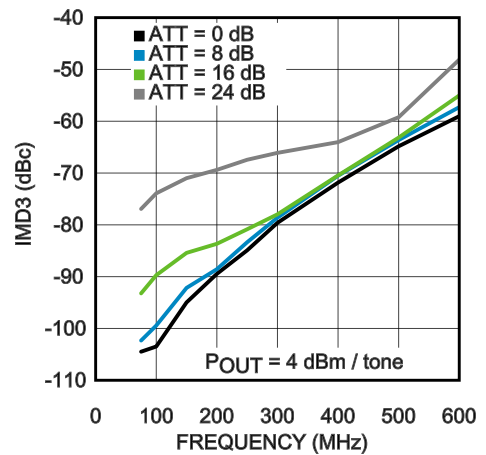

30120183

Third Order Harmonic Distortion vs. Frequency

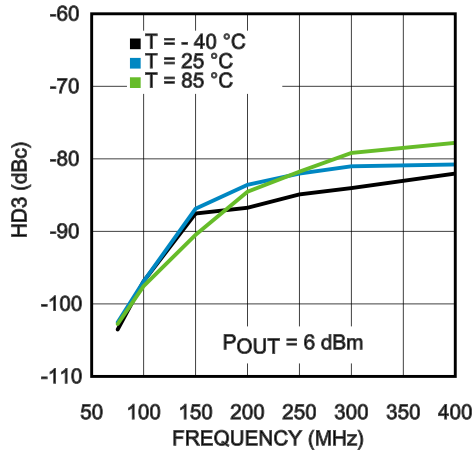

30120190

Second Order Harmonic Distortion vs. Attenuation

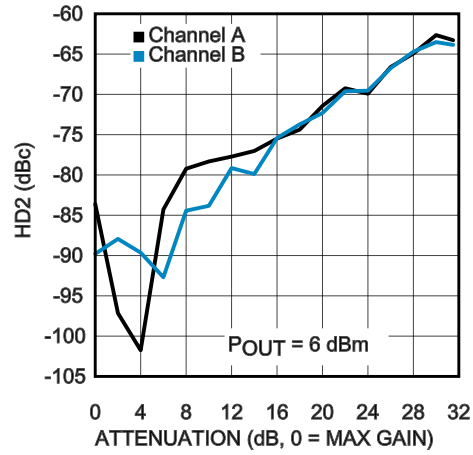

30120181

Third Order Harmonic Distortion vs. Attenuation

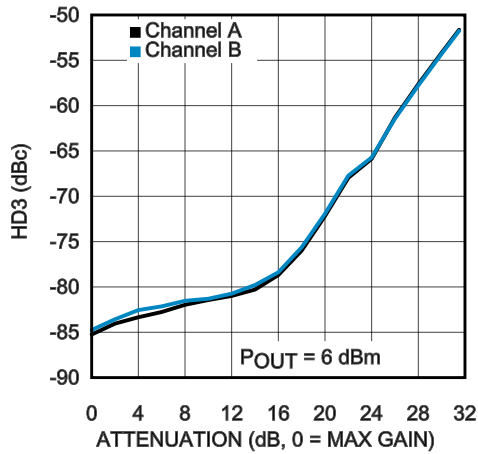

30120195

Second Order Harmonic Distortion vs. Frequency

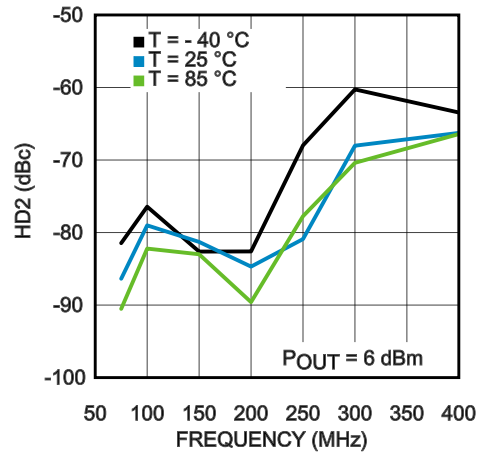

30120189

Second Order Harmonic Distortion at 100 MHz

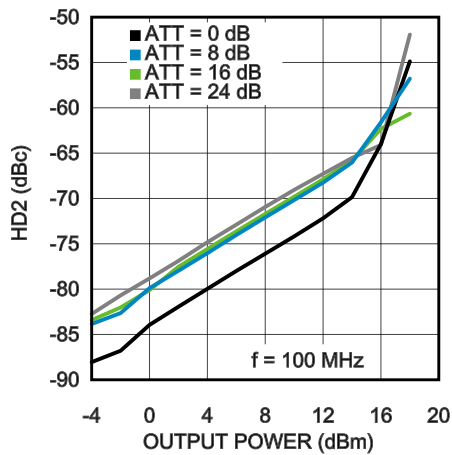

30120193

Third Order Harmonic Distortion at 100 MHz

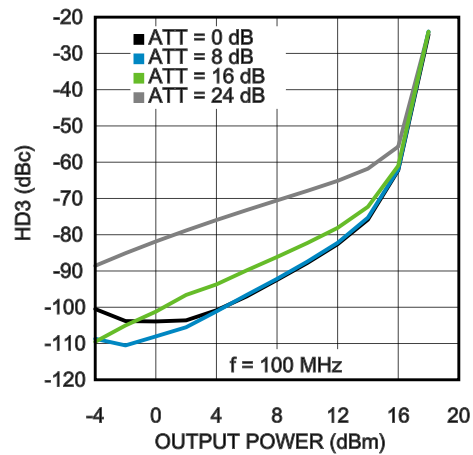

30120194

Second Order Harmonic Distortion at 200 MHz

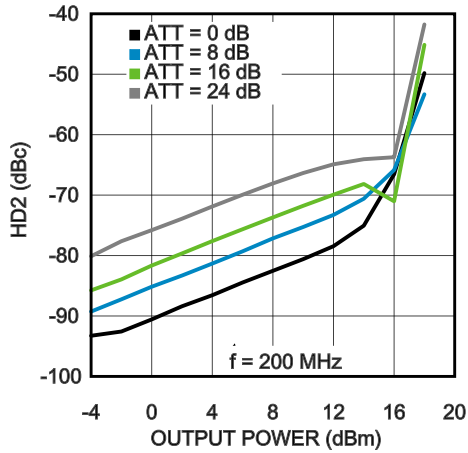

30120191

Third Order Harmonic Distortion at 200 MHz

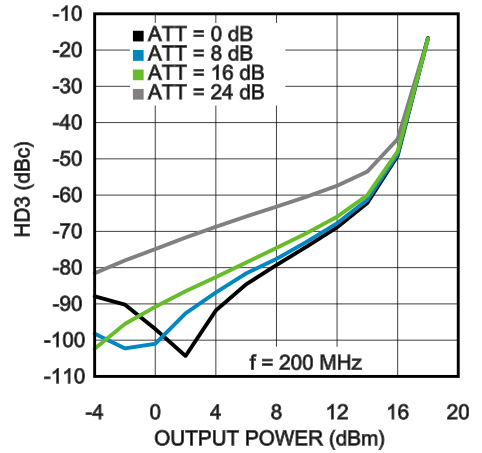

30120192

Cumulative Gain Error

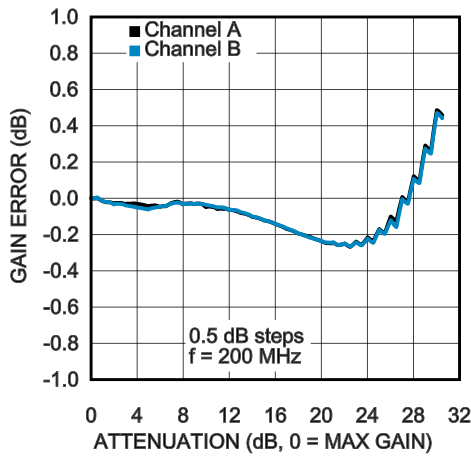

30120173

Cumulative Phase Shift

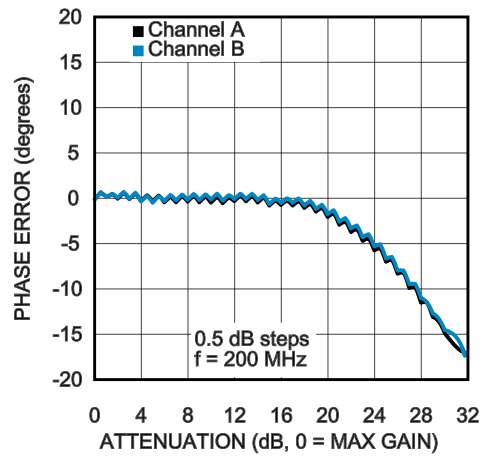

30120175

Noise Figure vs. Frequency

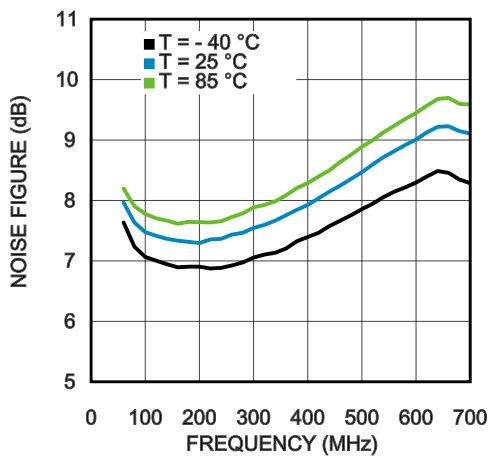

30120171

Noise Figure vs. Attenuation

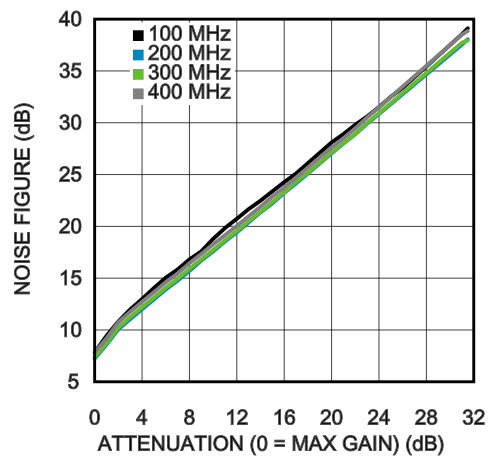

30120184

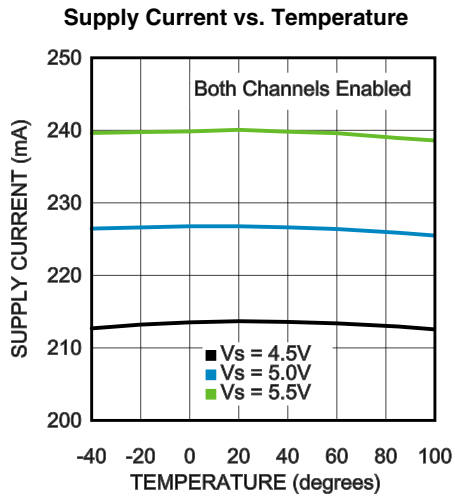

30120188

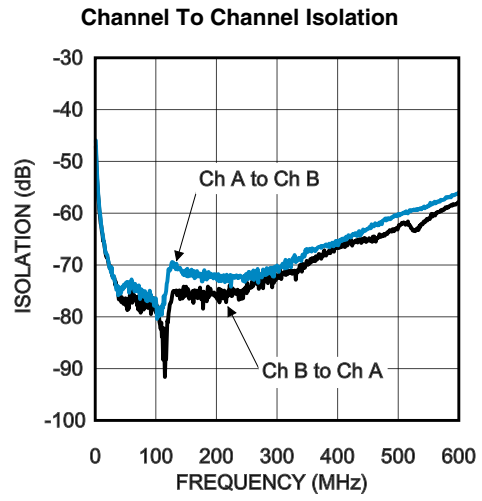

30120196

Application Information

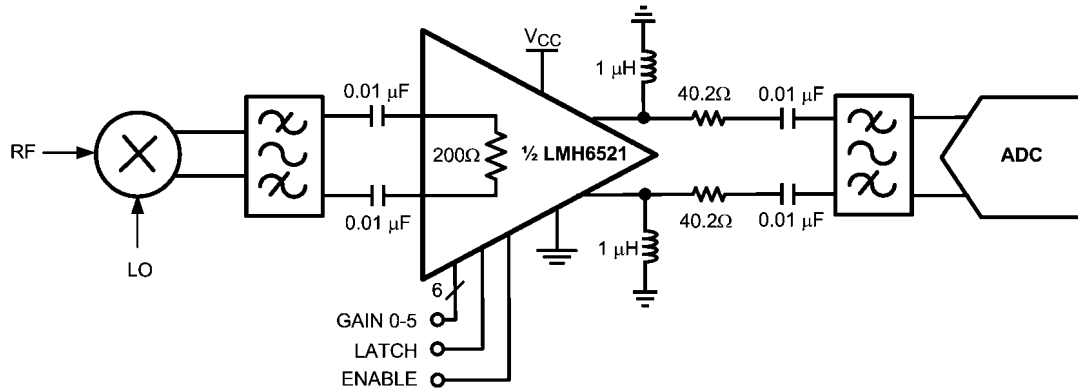

30120101

FIGURE 1. LMH6521 Typical Application

Introduction

The LMH6521 is a dual digitally controlled variable gain amplifier designed for narrowband and wideband intermediate frequency sampling applications. The LMH6521 is optimized for accurate 0.5 dB gain steps with exceptional gain and phase matching between channels combined with low distortion products. Gain matching error less than ± 0.05 dB and phase matching error less than ± 0.5 degrees over the entire attenuation range. This makes the LMH6521 ideal for driving analog-to-digital converters where high linearity is necessary. shows a typical application circuit.

The LMH6521 has been designed for AC coupled applications and has been optimized to operate at frequencies greater than 3 MHz.

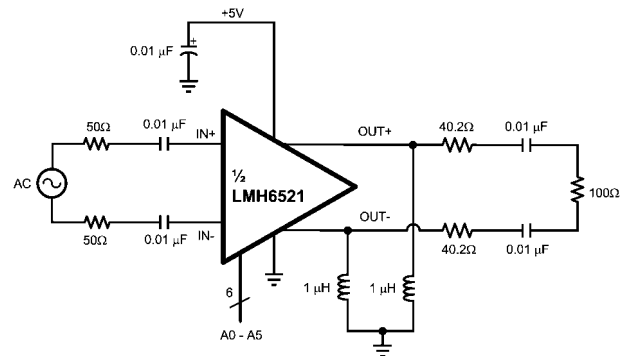

30120124

FIGURE 2. Basic Operating Connection

BASIC CONNECTIONS

A voltage between 4.75 V and 5.25 V should be applied to the supply pin labeled +5V. Each supply pin should be decoupled with a low inductance, surface-mount ceramic capacitor of 0.1μF as close to the device as possible.

The outputs of the LMH6521 are low impedance devices that need to be connected to ground with 1μH RF chokes and require ac-coupling capacitors of 0.01μF. The input pins are self biased to 2.5V and should be ac-coupled with 0.01μF capacitors as well. The output RF inductors and ac-coupling capacitors are the main limitations for operating at low frequencies.

Each channel of the LMH6521 consists of a digital step attenuator followed by a low distortion 26 dB fixed gain amplifier and a low impedance output stage. The gain is digitally controlled over a 31.5 dB range from +26dB to -5.5dB. The LMH6521 has a 200Ω differential input impedance and a low 20Ω differential output impedance.

To enable each channel of the LMH6521, the ENA and ENB pins can be left to float, which internally is connected high with a weak pull-up resistor. Externally connecting ENA and ENB to ground will disable the channels of the LMH6521 and reduce the current consumption to 17.5mA per channel.

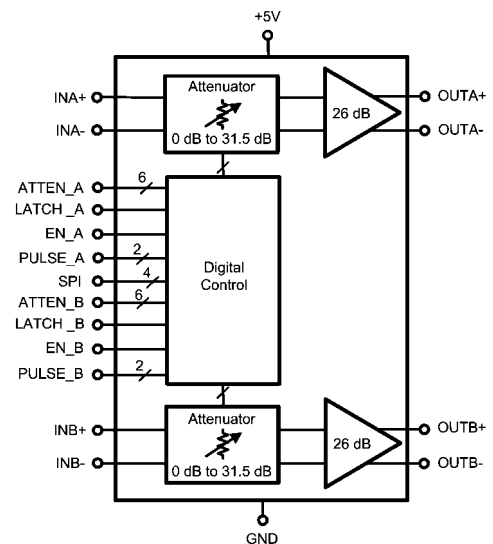

30120102

FIGURE 3. LMH6521 Block Diagram

INPUT CHARACTERISTICS

The LMH6521 input impedance is set by internal resistors to a nominal 200Ω. At higher frequencies device parasitic reactances will start to impact the input impedances. Refer to the input impedance graph in the typical characteristics section for more details

For many AC coupled applications the impedance can be easily changed using LC circuits to transform the actual impedance to the desired impedance.

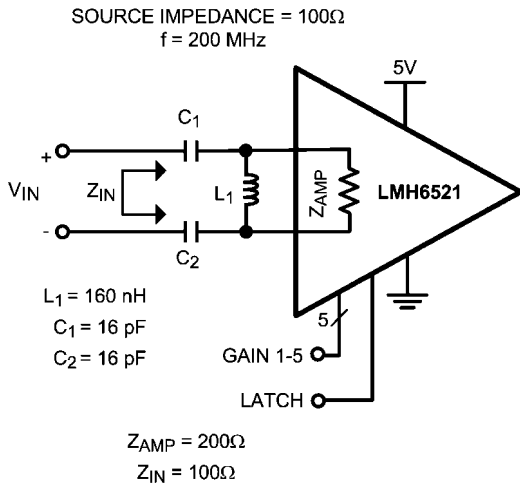

30120169

FIGURE 4. Differential 200Ω LC Conversion Circuit

In *Figure 4* a circuit is shown that matches the amplifier 200Ω input with a source impedance of 100Ω.

To avoid undesirable signal transients the LMH6521 should not be powered on with large inputs signals present. Careful planning of system power on sequencing is especially important to avoid damage to ADC inputs.

OUTPUT CHARACTERISTICS

The LMH6521 has a low output impedance very similar to a traditional operational amplifier output. This means that a wide range of load impedance can be driven with minimal gain loss. Matching load impedance for proper termination of filters is as easy as inserting the proper value of resistor between the filter and the amplifier. This flexibility makes system design and gain calculations very easy. The LMH6521 was designed to run from a single 5V supply. In spite of this low supply voltage the LMH6521 is still able to deliver very high power gains when driving low impedance loads.

OUTPUT CONNECTIONS

The LMH6521, like most high frequency amplifiers, is sensitive to loading conditions on the output. Load conditions that include small amounts of capacitance connected directly to the output can cause stability problems. An example of this is shown in *Figure 5*. A more sophisticated filter may require better impedance matching. Refer to *Figure 17* for an example filter configuration and table *IF Frequency Bandpass Filter Component Values* for some IF filter components values.

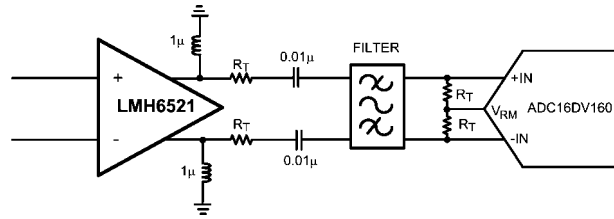

30120168

FIGURE 5. Example Output Configuration

The outputs of the LMH6521 need to be biased to near ground potential. On the evaluation board, 1μH inductors are installed to provide proper output biasing. The bias current is approximately 36mA per output pin and is not a function of the load condition, which makes the LMH6521 robust to handle various output load conditions while maintaining superior linearity as shown in *Figure 6*. With large inductors and high operating frequencies the inductor will present a very high impedance and will have minimal AC current. If the inductor is chosen to have a smaller value, or if the operating frequency is very low there could be enough AC current flowing in the inductor to become significant. Make sure to check the inductor datasheet to not exceed the maximum current limit.

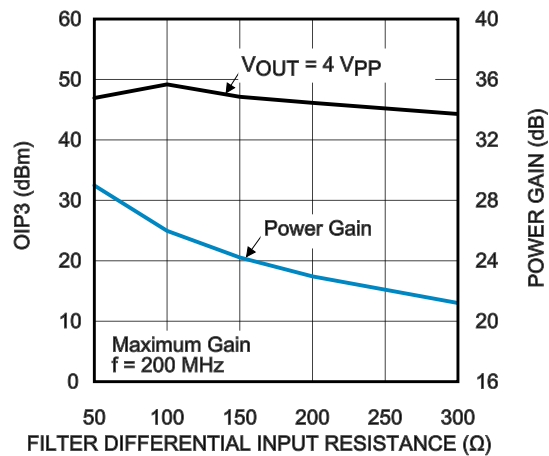

30120120

FIGURE 6. OIP3 vs Amplifier Load Resistance

DIGITAL CONTROL

The LMH6521 will support three modes of gain control, parallel mode, serial mode (SPI compatible) and pulse mode. Parallel mode is fastest and requires the most board space for logic line routing. Serial mode is compatible with existing SPI compatible systems. The pulse mode is both fast and compact, but must step through intermediate gain steps when making large gain changes.

Pins MOD0 and MOD1 are used to configure the LMH6521 for the three gain control modes. MOD0 and MOD1 have weak pull-up resistors to an internal 2.5V reference but is designed for 2.5V-5V CMOS logic levels. MOD0 and MOD1 can be externally driven (LOGIC HIGH) to voltages between 2.5V to 5V to configure the LMH6521 into one of the three digital control modes. Some pins on the LMH6521 have different functions depending on the digital control mode. These functions are shown in the *Digital Control Mode Pin Functions* table.

PARALLEL MODE (MOD1= 1, MOD0 = 1)

When designing a system that requires very fast gain changes parallel mode is the best selection. Refer to *Digital Control Mode Pin Functions* table for pin definitions of the LMH6521 in parallel mode.

The LMH6521 has a 6-bit gain control bus as well as latch pins LATA and LATB for channels A and B. When the latch pin is low, data from the gain control pins is immediately sent to the gain circuit (i.e. gain is changed immediately). When the latch pin transitions high the current gain state is held and subsequent changes to the gain set pins are ignored. To minimize gain change glitches multiple gain control pins should not change while the latch pin is low. Gain glitches could result from timing skew between the gain set bits. This is especially the case when a small gain change requires a change in state of three or more gain control pins. If continuous gain control is desired the latch pin can be tied to ground. This state is called transparent mode and the gain pins are always active. In this state the timing of the gain pin logic transitions should be planned carefully to avoid undesirable transients

ENA and ENB pins are provided to reduce power consumption by disabling the highest power portions of the LMH6521. The gain register will preserve the last active gain setting during the disabled state. These pins will float high and can be left disconnected if they won't be used. If the pins are left disconnected a 0.01uF capacitor to ground will help prevent external noise from coupling into these pins.

Figure 7, Figure 8, and Figure 9 show the various connections in parallel mode with respect to the latch pin.

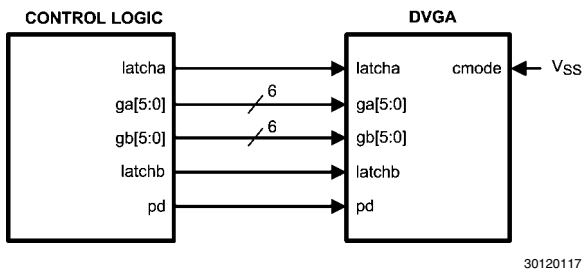

FIGURE 7. Parallel Mode Connection for Fastest Response

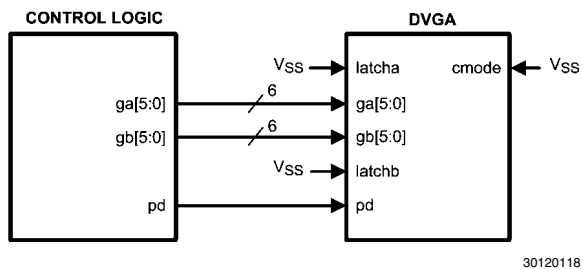

FIGURE 8. Parallel Mode Connection Not Using Latch Pins (Latch pins tied to logic low state)

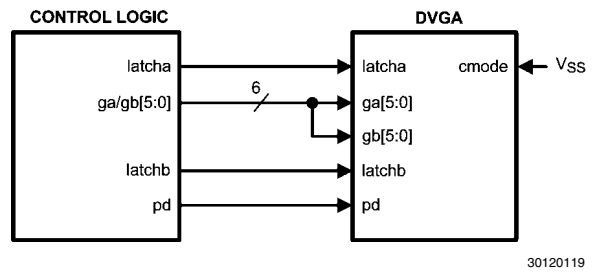

FIGURE 9. Parallel Mode Connection Using Latch Pins to Mux Digital Data

SERIAL MODE — SPI™ COMPATIBLE INTERFACE (MOD1= 1, MOD0 = 0)

Serial interface allows a great deal of flexibility in gain programming and reduced board complexity. Using only 4 wires for both channels allows for significant board space savings. The trade off for this reduced board complexity is slower response time in gain state changes. For systems where gain is changed only infrequently or where only slow gain changes are required serial mode is the best choice. Refer to *Digital Control Mode Pin Functions* table for pin definitions of the LMH6521 in serial mode.

The LMH6521 has a serial interface that allows access to the control registers. The serial interface is a generic 4-wire synchronous interface that is compatible with SPI standard interfaces and used on many microcontrollers and DSP controllers.

The serial mode is active when the two mode pins are set as follows: MOD1=1, MOD0=0). In this configuration the pins function as shown in the pin description table. The SPI interface uses the following signals: clock input (CLK), serial data in (SDI), serial data out, and serial chip select (CS)

ENA and ENB pins are active in serial mode. For fast disable capability these pins can be used and the serial register will hold the last active gain state. These pins will float high and can be left disconnected for serial mode. The serial control bus can also disable the DVGA channels, but at a much slower speed. The serial enable function is an AND function. For a channel to be active both the enable pin and the serial control register must be in the enabled state. To disable a channel either method will suffice. See the Typical Performance section for disable and enable timing information.

LATA and LATB pins are not active during serial mode.

The serial clock pin CLK is used to register the input data that is presented on the SDI pin on the rising edge; and to source the output data on the SDO pin on the falling edge. User may disable clock and hold it in the low state, as long as the clock pulse-width minimum specification is not violated when the clock is enabled or disabled.

The chip select pin CS starts a new register access with each assertion - i.e., the SDATA field protocol is required. The user is required to deassert this signal after the 16th clock. If the SCSb is deasserted before the 16th clock, no address or data write will occur. The rising edge captures the address just shifted-in and, in the case of a write operation, writes the addressed register. There is a minimum pulse-width requirement for the deasserted pulse - which is specified in the Electrical Specifications section.

SDI is an input pin for the serial data. It must observe setup/hold requirements with respect to the SCLK. Each cycle is 16-bits long

SDO is the data output pin and is normally at TRI-STATE® and is driven only when SCSb is asserted. Upon SCSb assertion, contents of the register addressed during the first byte are shifted out with the second 8 SCLK falling edges. Upon power-up, the default register address is 00h

The SDO internal driver circuit is an open collector device with a weak pull-up resistor to an internal 2.5V reference. It is 5V tolerant so an external pull-up resistor can connect to 2.5V, 3.3V or 5V as shown in Figure 11. However, the external pull-up resistor should be chosen to limit the current to 11mA or less. Otherwise the SDO logic low output level (V_{OL}) may not

achieve close to ground and in extreme case could cause problem for FPGA input gate. Using minimum values for external pull-up resistor is a good to maximize speed for SDO signal. So if high SPI clock frequency is needed then minimum value external pull-up resistor is the best choice as shown in Figure 11.

Each serial interface access cycle is exactly 16 bits long as shown in Figure 10. Each signal's function is described below. The read timing is shown in Figure 12, while the write timing is shown in figure Figure 13.

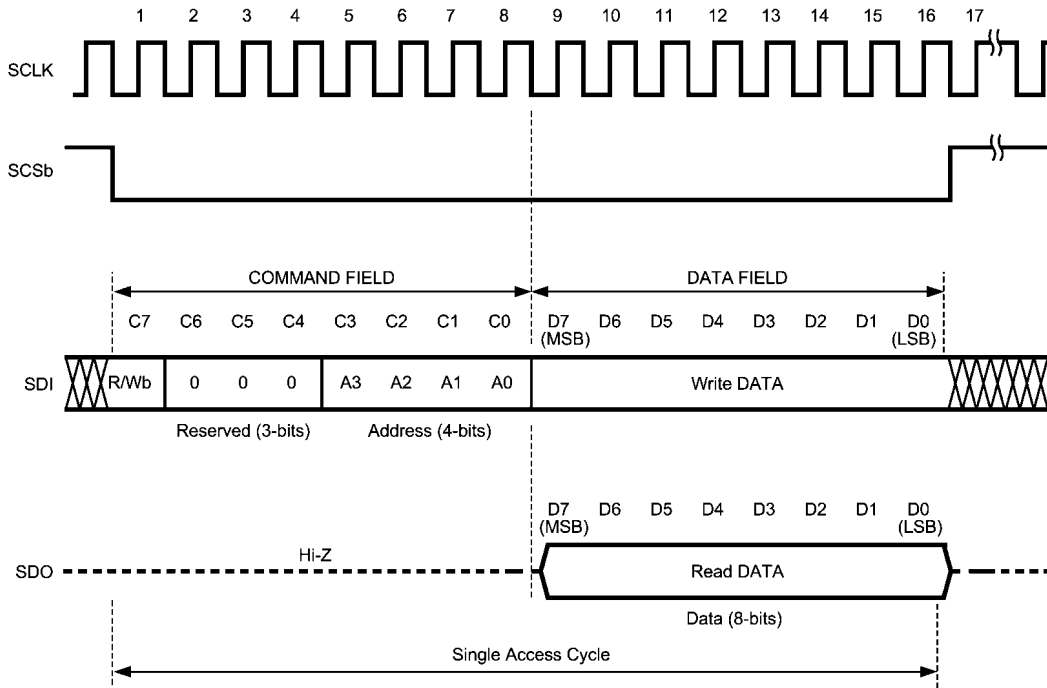

30120112

FIGURE 10. Serial Interface Protocol (SPI compatible)

R/Wb	Read / Write bit. A value of 1 indicates a read operation, while a value of 0 indicates a write operation.
Reserved	Not used. Must be set to 0.
ADDR:	Address of register to be read or written.
DATA	In a write operation the value of this field will be written to the addressed register when the chip select pin is deasserted. In a read operation this field is ignored.

Serial Word Format for LMH6521

C7	C6	C5	C4	C3	C2	C1	C0
0= write	0	0	0	0	0	0	0=Ch A
1=read							1=Ch B

Serial Word Format for LMH6521 (cont)

Enable	Gb5	Gb4	Gb3	Gb2	Gb1	Gb0	RES
0=Off	1=	1=	1=	1=	1=	1=	0
1=On	+16dB	+8dB	+4dB	+2dB	+1dB	+0.5dB	

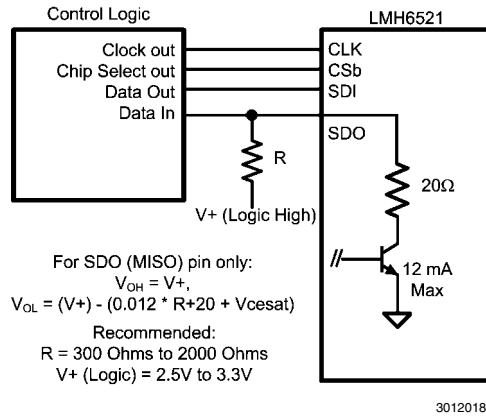

FIGURE 11. Serial Mode 4-wire Connection

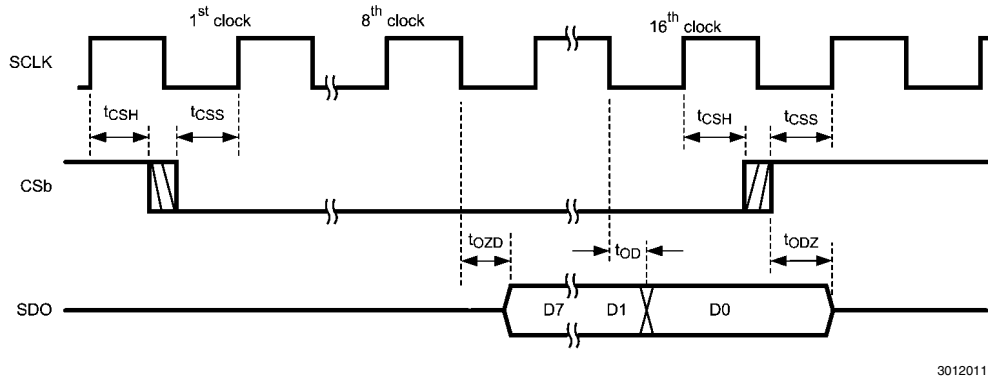

FIGURE 12. Read Timing

Read Timing
Data Output on SDO Pin

Parameter	Description
t_{CSH}	Chip select hold time
t_{CSS}	Chip select setup time
t_{ODZ}	Initial output data delay
t_{ODZ}	High impedance delay
t_{OD}	Output data delay

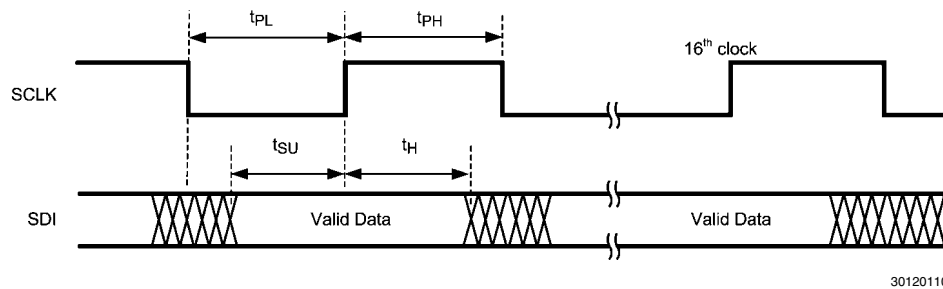

FIGURE 13. Write Timing
Data Written to SDI Pin

Write Timing Data Input on SDI Pin

Parameter	Description
t_{PL}	Minimum clock low time (clock duty cycle)
t_{PH}	Minimum clock high time (clock duty cycle)
t_{SU}	Input data setup time
t_H	Input data hold time

PULSE MODE (MOD1 = 0, MOD0 = 1)

Pulse mode is a simple yet fast way to adjust gain settings. Using only two control lines per channel the LMH6521 gain can be changed by simple up and down signals. Gain steps are selectable either by hard wiring the board or using two additional logic inputs. For a system where gain changes can be stepped sequentially from one gain to the next and where board space is limited this mode may be the best choice. The ENA and ENB pins are fully active during pulse mode, and the channel gain state is preserved during the disabled state. Refer to [Digital Control Mode Pin Functions](#) table for pin definitions of the LMH6521 in pulse mode.

In this mode the gain step size can be selected from a choice of 0.5, 1, 2 or 6dB steps. During operation the gain can be quickly adjusted either up or down one step at a time by a negative pulse on the UP or DN pins. As shown in [Figure 15](#) each gain step pulse must have a logic high state of at least $t_{PW} = 20$ ns and a logic low state of at least $t_{PG} = 20$ ns for the pulse to register as a gain change signal.

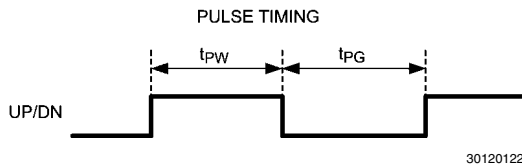

FIGURE 14.

To provide a known gain state there is a reset feature in pulse mode. To reset the gain to maximum gain both the UP and DN pins must be strobed low together as shown in [Figure 15](#). There must be an overlap of at least $t_{RW} = 20$ ns for the reset to register.

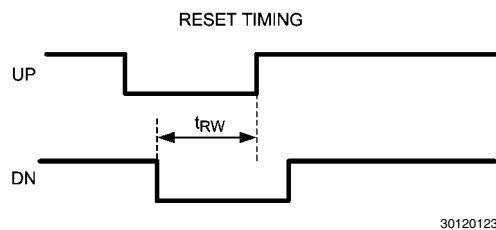

FIGURE 15. Pulse Mode Timing

THERMAL MANAGEMENT

The LMH6521 is packaged in a thermally enhanced LLP package and features an exposed pad that is connected to the GND pins. It is recommended that the exposed pad be attached directly to a large power supply ground plane for maximum heat dissipation. The thermal advantage of the LLP package is fully realized only when the exposed die attach pad is soldered down to a thermal land on the PCB board with the through vias planted underneath the thermal land. The thermal land can be connected to any ground plane within the

PCB. However, it is also very important to maintain good high speed layout practices when designing a system board.

The LMH6521EVAL evaluation board implemented an eight metal layer design with (a) 4 oz. copper inner ground planes (b) additional through vias and (c) maximum bottom layer metal coverage to assist with device heat dissipation. Please refer to the LMH6521EVAL evaluation board application note 2045 for suggested layout techniques.

Package information is available on the National web site. <http://www.national.com/packaging/folders/SQA32A.html>

INTERFACE TO ADC

The LMH6521 was designed to be used with National Semiconductor's high speed ADC's. As shown in [Figure 1](#), AC coupling provides the best flexibility especially for IF sub-sampling applications. For DC coupled applications the use of a level shifting amplifier or a resistive biasing network may be possible.

The inputs of the LMH6521 will self bias to the optimum voltage for normal operation. The internal bias voltage for the inputs is approximately mid rail which is 2.5V with the typical 5V power supply condition. In most applications the LMH6521 input will need to be AC coupled.

The LMH6521 output common mode voltage is biased to 0V and has a maximum differential output voltage swing of $10V_{PPD}$ as shown in [Figure 16](#). This means that for driving most ADCs AC coupling is required. Since most often a band pass filter is desired between the amplifier and ADC the band-pass filter can be configured to block the DC voltage of the amplifier output from the ADC input. [Figure 17](#) shows a sample bandpass filter configuration that could be designed for a 200Ω impedance system.

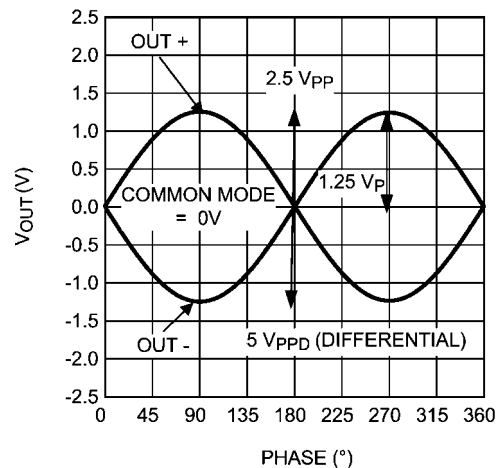

FIGURE 16. Output Voltage with Respect to Output Common Mode

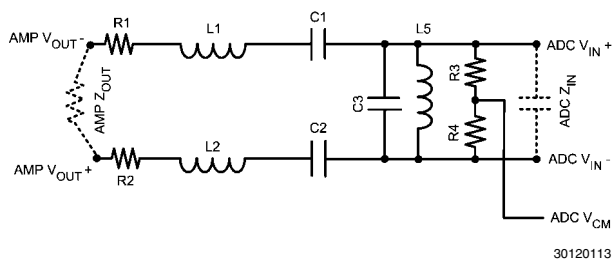

FIGURE 17. Sample Bandpass Filter

ADC Noise Filter

Table *IF Frequency Bandpass Filter Component Values* below show values for some common IF frequencies for [Figure 17](#). The filter shown in [Figure 17](#) offers a good compromise between bandwidth, noise rejection and cost. This filter topology is the same as is used on the ADC14V155KDRB High IF Receiver reference design board. This filter topology works best with the 12 to 16 bit analog to digital converters shown in the table.

IF Frequency Bandpass Filter Component Values

Center Frequency	75 MHz	150 MHz	180 MHz	250 MHz
Bandwidth	40 MHz	60 MHz	75 MHz	100 MHz
R1, R2	90 Ω	90 Ω	90 Ω	90 Ω
L1, L2	390 nH	370 nH	300 nH	225 nH
C1, C2	10 pF	3 pF	2.7 pF	1.9 pF
C3	22 pF	19 pF	15 pF	11 pF
L5	220 nH	62 nH	54 nH	36 nH
R3, R4	100 Ω	100 Ω	100 Ω	100 Ω

POWER SUPPLIES

The LMH6521 was designed primarily to be operated on 5V power supplies. The voltage range for V_{CC} is 4.75V to 5.25V. When operated on a board with high speed digital signals it is important to provide isolation between digital signal noise and the LMH6521 inputs. The SP16160CH1RB reference board provides an example of good board layout.

COMPATIBLE HIGH SPEED ANALOG TO DIGITAL CONVERTERS

Product Number	Max Sampling Rate (MSPS)	Resolution	Channels
ADC12L063	62	12	SINGLE
ADC12DL065	65	12	DUAL
ADC12L066	66	12	SINGLE
ADC12DL066	66	12	DUAL
CLC5957	70	12	SINGLE
ADC12L080	80	12	SINGLE
ADC12DL080	80	12	DUAL
ADC12C080	80	12	SINGLE
ADC12C105	105	12	SINGLE
ADC12C170	170	12	SINGLE
ADC12V170	170	12	SINGLE
ADC14C080	80	14	SINGLE
ADC14C105	105	14	SINGLE
ADC14DS105	105	14	DUAL
ADC14155	155	14	SINGLE
ADC14V155	155	14	SINGLE
ADC16V130	130	16	SINGLE
ADC16DV160	160	16	DUAL
ADC08D500	500	8	DUAL
ADC08500	500	8	SINGLE
ADC08D1000	1000	8	DUAL
ADC081000	1000	8	SINGLE
ADC08D1500	1500	8	DUAL
ADC081500	1500	8	SINGLE
ADC08(B)3000	3000	8	SINGLE
ADC08L060	60	8	SINGLE
ADC08060	60	8	SINGLE
ADC10DL065	65	10	DUAL
ADC10065	65	10	SINGLE
ADC10080	80	10	SINGLE
ADC08100	100	8	SINGLE
ADCS9888	170	8	SINGLE
ADC08(B)200	200	8	SINGLE
ADC11C125	125	11	SINGLE
ADC11C170	170	11	SINGLE

Physical Dimensions inches (millimeters) unless otherwise noted

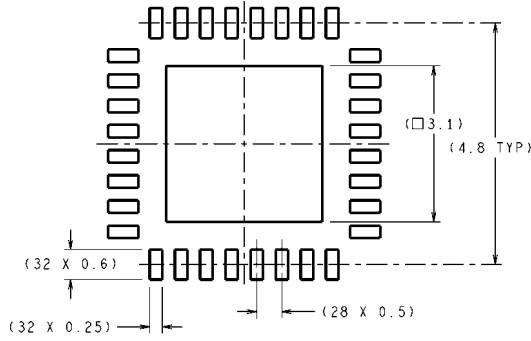

DIMENSIONS ARE IN MILLIMETERS
DIMENSIONS IN () FOR REFERENCE ONLY

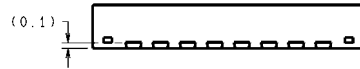

RECOMMENDED LAND PATTERN

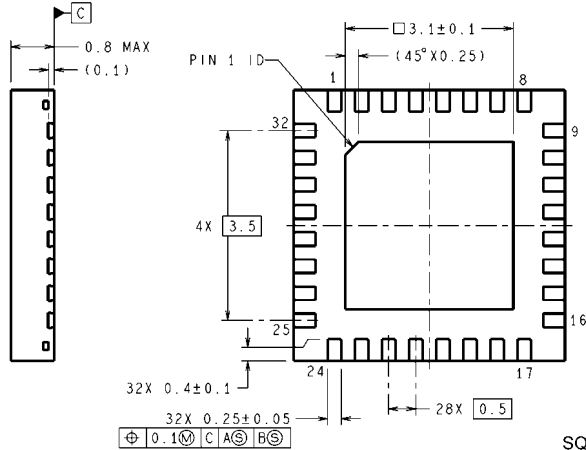
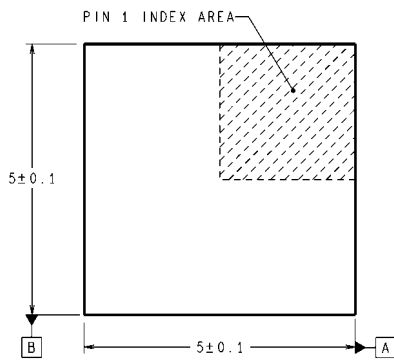

32-Pin Package
NS Package Number SQA32A

SQA32A (Rev B)

Notes

LMH6521

Notes

For more National Semiconductor product information and proven design tools, visit the following Web sites at:
www.national.com

Products		Design Support	
Amplifiers	www.national.com/amplifiers	WEBENCH® Tools	www.national.com/webench
Audio	www.national.com/audio	App Notes	www.national.com/appnotes
Clock and Timing	www.national.com/timing	Reference Designs	www.national.com/refdesigns
Data Converters	www.national.com/adc	Samples	www.national.com/samples
Interface	www.national.com/interface	Eval Boards	www.national.com/evalboards
LVDS	www.national.com/lvds	Packaging	www.national.com/packaging
Power Management	www.national.com/power	Green Compliance	www.national.com/quality/green
Switching Regulators	www.national.com/switchers	Distributors	www.national.com/contacts
LDOs	www.national.com/lido	Quality and Reliability	www.national.com/quality
LED Lighting	www.national.com/led	Feedback/Support	www.national.com/feedback
Voltage References	www.national.com/vref	Design Made Easy	www.national.com/easy
PowerWise® Solutions	www.national.com/powerwise	Applications & Markets	www.national.com/solutions
Serial Digital Interface (SDI)	www.national.com/sdi	Mil/Aero	www.national.com/milaero
Temperature Sensors	www.national.com/tempensors	SolarMagic™	www.national.com/solarmagic
PLL/VCO	www.national.com/wireless	PowerWise® Design University	www.national.com/training

THE CONTENTS OF THIS DOCUMENT ARE PROVIDED IN CONNECTION WITH NATIONAL SEMICONDUCTOR CORPORATION ("NATIONAL") PRODUCTS. NATIONAL MAKES NO REPRESENTATIONS OR WARRANTIES WITH RESPECT TO THE ACCURACY OR COMPLETENESS OF THE CONTENTS OF THIS PUBLICATION AND RESERVES THE RIGHT TO MAKE CHANGES TO SPECIFICATIONS AND PRODUCT DESCRIPTIONS AT ANY TIME WITHOUT NOTICE. NO LICENSE, WHETHER EXPRESS, IMPLIED, ARISING BY ESTOPPEL OR OTHERWISE, TO ANY INTELLECTUAL PROPERTY RIGHTS IS GRANTED BY THIS DOCUMENT.

TESTING AND OTHER QUALITY CONTROLS ARE USED TO THE EXTENT NATIONAL DEEMS NECESSARY TO SUPPORT NATIONAL'S PRODUCT WARRANTY. EXCEPT WHERE MANDATED BY GOVERNMENT REQUIREMENTS, TESTING OF ALL PARAMETERS OF EACH PRODUCT IS NOT NECESSARILY PERFORMED. NATIONAL ASSUMES NO LIABILITY FOR APPLICATIONS ASSISTANCE OR BUYER PRODUCT DESIGN. BUYERS ARE RESPONSIBLE FOR THEIR PRODUCTS AND APPLICATIONS USING NATIONAL COMPONENTS. PRIOR TO USING OR DISTRIBUTING ANY PRODUCTS THAT INCLUDE NATIONAL COMPONENTS, BUYERS SHOULD PROVIDE ADEQUATE DESIGN, TESTING AND OPERATING SAFEGUARDS.

EXCEPT AS PROVIDED IN NATIONAL'S TERMS AND CONDITIONS OF SALE FOR SUCH PRODUCTS, NATIONAL ASSUMES NO LIABILITY WHATSOEVER, AND NATIONAL DISCLAIMS ANY EXPRESS OR IMPLIED WARRANTY RELATING TO THE SALE AND/OR USE OF NATIONAL PRODUCTS INCLUDING LIABILITY OR WARRANTIES RELATING TO FITNESS FOR A PARTICULAR PURPOSE, MERCHANTABILITY, OR INFRINGEMENT OF ANY PATENT, COPYRIGHT OR OTHER INTELLECTUAL PROPERTY RIGHT.

LIFE SUPPORT POLICY

NATIONAL'S PRODUCTS ARE NOT AUTHORIZED FOR USE AS CRITICAL COMPONENTS IN LIFE SUPPORT DEVICES OR SYSTEMS WITHOUT THE EXPRESS PRIOR WRITTEN APPROVAL OF THE CHIEF EXECUTIVE OFFICER AND GENERAL COUNSEL OF NATIONAL SEMICONDUCTOR CORPORATION. As used herein:

Life support devices or systems are devices which (a) are intended for surgical implant into the body, or (b) support or sustain life and whose failure to perform when properly used in accordance with instructions for use provided in the labeling can be reasonably expected to result in a significant injury to the user. A critical component is any component in a life support device or system whose failure to perform can be reasonably expected to cause the failure of the life support device or system or to affect its safety or effectiveness.

National Semiconductor and the National Semiconductor logo are registered trademarks of National Semiconductor Corporation. All other brand or product names may be trademarks or registered trademarks of their respective holders.

Copyright© 2011 National Semiconductor Corporation

For the most current product information visit us at www.national.com



National Semiconductor Americas Technical Support Center
 Email: support@nsc.com
 Tel: 1-800-272-9959

National Semiconductor Europe Technical Support Center
 Email: europe.support@nsc.com

National Semiconductor Asia Pacific Technical Support Center
 Email: ap.support@nsc.com

National Semiconductor Japan Technical Support Center
 Email: jpn.feedback@nsc.com