

LMH6514

600 MHz, Digital Controlled, Variable Gain Amplifier

General Description

The LMH6514 is a high performance, digitally controlled variable gain amplifier (DVGA). It combines precision gain control with a low noise, ultra-linear, differential amplifier. Typically, the LMH6514 drives a high performance ADC in a broad range of mixed signal and digital communication applications such as mobile radio and cellular base stations where automatic gain control (AGC) is required to increase system dynamic range. When used in conjunction with a high speed ADC, system dynamic range can be extended by up to 42 dB.

The LMH6514 has a differential input and output allowing large signal swings on a single 5V supply. It is designed to accept signals from RF elements and maintain a terminated impedance environment. The input impedance is 200Ω and is user selectable. The output impedance is either 200Ω or 400Ω and is user selectable. A unique internal architecture allows use with both single ended and differential input signals.

Input signals to the LMH6514 are scaled by a highly linear, digitally controlled attenuator with seven accurate 6 dB steps. The attenuator output provides the input signal for a high gain, ultra linear differential transconductor. The transconductor differential output current can be converted into a voltage by using the on-chip 200Ω or 400Ω loads. The transconductance gain is 0.1 Amp/Volt resulting in a maximum voltage gain of +32 dB when driving a 200Ω load, or 38 dB when driving the 400Ω load. On chip digital latches are provided for local storage of the gain setting. The gain step settling time is 5 ns and care has been taken to reduce the sensitivity of bandwidth and phase to gain setting.

The LMH6514 operates over the industrial temperature range of -40°C to +85°C. The LMH6514 is available in a 16-Pin, thermally enhanced, LLP package.

Features

- Adjustable gain with a 42 dB range
- Precise 6.02 dB gain steps
- Parallel 3 bit gain control
- On chip register gain setting
- Fully differential signal path
- Single ended to differential capable
- 200Ω input impedance
- Small footprint (4 mm x 4 mm) LLP package

Key Specifications

- 600 MHz bandwidth at 100Ω load
- 39 dBm OIP3 at 75 MHz, 200Ω load
- 26 dB to 38 dB maximum gain
- Selectable output impedance of 200Ω or 400Ω.
- 8.3 dB noise figure
- 5 ns gain step switching time
- 100 mA supply current

Applications

- Cellular base stations
- IF sampling receivers
- Instrumentation
- Modems
- Imaging
- Differential line receiver

Typical Application

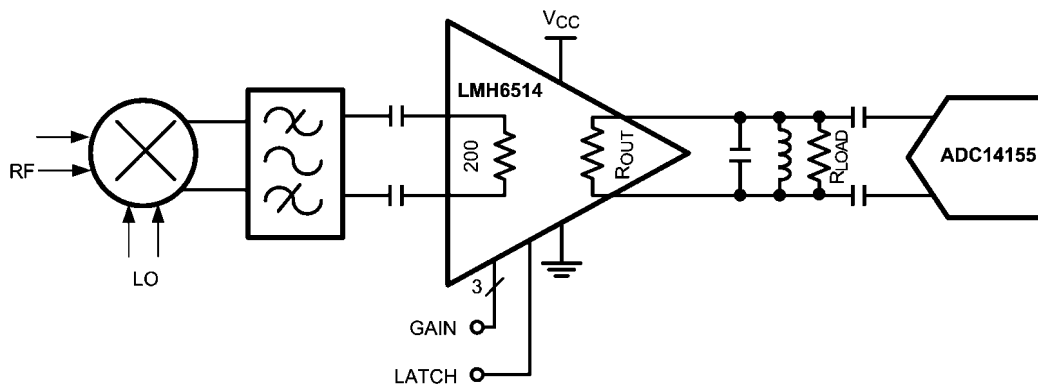

30042901

LMH™ is a trademark of National Semiconductor Corporation.

Absolute Maximum Ratings (Note 1)

If Military/Aerospace specified devices are required, please contact the National Semiconductor Sales Office/ Distributors for availability and specifications.

ESD Tolerance (Note 2)	
Human Body Model	2 kV
Machine Model	150V
Positive Supply Voltage (Pin 3)	-0.6V to 5.5V
Output Voltage (Pin 14,15)	-0.6V to 6.8V
Differential Voltage between Any Two Grounds	<200 mV
Analog Input Voltage Range	-0.6V to V_{CC}
Digital Input Voltage Range	-0.6V to 3.6V
Output Short Circuit Duration (one pin to ground)	Infinite
Junction Temperature	+150°C

Storage Temperature Range	-65°C to +150°C
Soldering Information	
Infrared or Convection (20 sec)	235°C
Wave Soldering (10 sec)	260°C

Operating Ratings (Note 1)

Supply Voltage (Pin 3)	4V to 5.25V
Output Voltage Range (Pin 14, 15)	1.4V to 6.4V
Differential Voltage Between Any Two Grounds	<10 mV
Analog Input Voltage Range, AC Coupled	±1.4V
Temperature Range (Note 3)	-40°C to +85°C
Package Thermal Resistance (θ_{JA})	
16-Pin LLP	47°C/W

5V Electrical Characteristics (Note 4)

The following specifications apply for single supply with $V_{CC} = 5V$, Maximum Gain, $R_L = 100\Omega$ (200 Ω external || 200 Ω internal), $V_{OUT} = 2 V_{PP}$, $f_{in} = 150$ MHz. Boldface limits apply at temperature extremes.

Symbol	Parameter	Conditions	Min (Note 6)	Typ (Note 5)	Max (Note 6)	Units
Dynamic Performance						
SSBW	-3 dB Bandwidth	Average of all Gain Settings		600		MHz
Noise and Distortion						
	Third Order Intermodulation Products	f = 75 MHz, $V_{OUT} = 2 V_{PP}$		-70		dBc
		f = 150 MHz, $V_{OUT} = 2 V_{PP}$		-66		
		f = 250 MHz, $V_{OUT} = 2 V_{PP}$		-60		
		f = 450 MHz, $V_{OUT} = 2 V_{PP}$		-52		
OIP3	Output Third Order Intercept Point	f = 75 MHz, $V_{OUT} = 2 V_{PP}$, Tone Spacing = 0.5 MHz		35		dBm
		f = 150 MHz, $V_{OUT} = 2 V_{PP}$, Tone Spacing = 2 MHz		33		
		f = 250 MHz, $V_{OUT} = 2 V_{PP}$, Tone Spacing = 2 MHz		31		
		f = 75 MHz, $R_L = 200\Omega$, $V_{OUT} = 2 V_{PP}$, Tone Spacing = 0.5 MHz		39		
		f = 150 MHz, $R_L = 200\Omega$, $V_{OUT} = 2 V_{PP}$, Tone Spacing = 2 MHz		37		
		f = 250 MHz, $R_L = 200\Omega$, $V_{OUT} = 2 V_{PP}$, Tone Spacing = 2 MHz		34		
P1 dB	Output Level for 1 dB Gain Compression	f = 75 MHz, $R_L = 200\Omega$		16.7		dBm
		f = 250 MHz, $R_L = 200\Omega$		14.7		
		f = 75 MHz		14.5		
		f = 450 MHz		13.2		
VNI	Input Noise Voltage	Maximum Gain, f = 40 MHz		1.8		nV/ \sqrt{Hz}
VNO	Output Noise Voltage	Maximum Gain, f = 40 MHz		36		nV/ \sqrt{Hz}
NF	Noise Figure	Maximum Gain		8.3		dB
Analog I/O						
	Differential Input Resistance		165 158	188	220 230	Ω
	Input Common Mode Resistance		825 785	955	1120 1160	Ω

Symbol	Parameter	Conditions	Min (Note 6)	Typ (Note 5)	Max (Note 6)	Units
	Differential Output Resistance	Low Gain Option		186		Ω
		High Gain Option	330 325	370	420 425	
	Internal Load Resistors	Between Pins 13, 14 and Pins 15, 16	165 158	187	215 225	Ω
	Input Signal Level (AC Coupled)	Max Gain, $V_O = 2 V_{PP}$, $R_L = 1 k\Omega$		63		mV_{PP}
	Maximum Differential Input Signal	AC Coupled		5.6		V_{PP}
	Input Common Mode Voltage	Self Biased	1.3 1.1	1.4	1.5 1.7	V
	Input Common Mode Voltage Range	Driven Externally		0.9 to 2.0		V
	Minimum Input Voltage	DC		0		V
	Maximum Input Voltage	DC		3.3		V
	Maximum Differential Output Voltage Swing	$V_{CC} = 5V$, Output Common Mode = 5V		5.5		V_{PP}
V_{OS}	Output Offset Voltage	All Gain Settings		-21		mV
CMRR	Common Mode Rejection Ratio	Maximum Gain		81		dB
PSRR	Power Supply Rejection Ratio	Maximum Gain	63 61	81		dB
Gain Parameters						
	Maximum Gain	DC, Internal $R_L = 186\Omega$, External $R_L = 1280\Omega$	29.3 28.7	30	30.3 30.9	dB
	Minimum Gain	DC, Internal $R_L = 186\Omega$, External $R_L = 1280\Omega$	-12.75 -13.15	-12	-11.85 -11.45	dB
	Gain Step Size	DC		6.02		dB
	Gain Step Error	DC		0.02		dB
		$f = 150$ MHz			0.07	
	Cumulative Gain Step Error	DC, Gain Step 7 to Gain Step 0	-0.35 -0.50	0.02	0.30 0.45	dB
	Gain Step Switching Time			5		ns
Digital Inputs/Timing						
	Logic Compatibility	CMOS Logic		3.3		V
VIL	Logic Input Low Voltage				0.8	V
VIH	Logic Input High Voltage		2.0			V
IIH	Logic Input High Input Current	Digital Input Voltage = 3.3V		33	40	μA
TSU	Setup Time			3		ns
THOLD	Hold Time			3		ns
TPW	Minimum Latch Pulse Width			10		ns
Power Requirements						
ICC	Total Supply Current	$V_{OUT} = 0V$ Differential, V_{OUT} Common Mode = 5V		107	124 134	mA
	Amplifier Supply Current	Pin 3 Only		56	66 74	mA
	Output Stage Bias Currents	Pins 13, 14 and Pins 15, 16; V_{OUT} Common Mode = 5 V		51	58 60	mA

Note 1: Absolute Maximum Ratings indicate limits beyond which damage to the device may occur. Operating Ratings indicate conditions for which the device is intended to be functional, but specific performance is not guaranteed. For guaranteed specifications, see the Electrical Characteristics tables.

Note 2: Human Body Model, applicable std. MIL-STD-883, Method 3015.7. Machine Model, applicable std. JESD22-A115-A (ESD MM std. of JEDEC) Field-Induced Charge-Device Model, applicable std. JESD22-C101-C (ESD FICDM std. of JEDEC).

Note 3: The maximum power dissipation is a function of $T_{J(MAX)}$, θ_{JA} . The maximum allowable power dissipation at any ambient temperature is $P_D = (T_{J(MAX)} - T_A) / \theta_{JA}$. All numbers apply for packages soldered directly onto a PC Board.

Note 4: Electrical Table values apply only for factory testing conditions at the temperature indicated. No guarantee of parametric performance is indicated in the electrical tables under conditions different than those tested

Note 5: Typical values represent the most likely parametric norm as determined at the time of characterization. Actual typical values may vary over time and will also depend on the application and configuration. The typical values are not tested and are not guaranteed on shipped production material.

Note 6: Limits are 100% production tested at 25°C. Limits over the operating temperature range are guaranteed through correlation using Statistical Quality Control (SQC) methods.

Note 7: Negative input current implies current flowing out of the device.

Note 8: Drift determined by dividing the change in parameter at temperature extremes by the total temperature change.

Connection Diagram

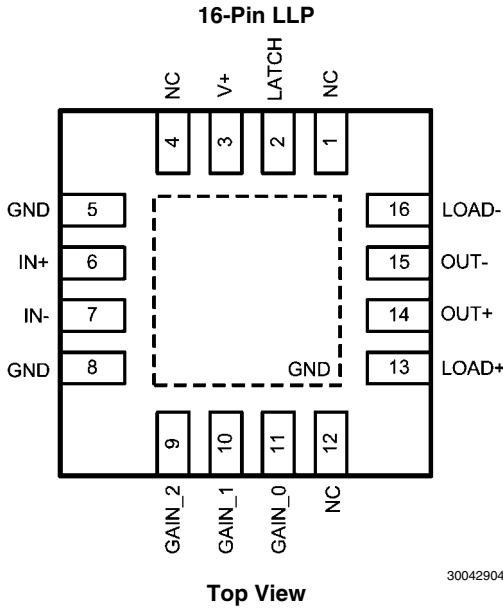

Gain Control Pins

Pin Number	Pin Name	Gain Step Size
11	GAIN_0	6.02 dB
10	GAIN_1	12.04 dB
9	GAIN_2	24.08 dB

Ordering Information

Package	Part Number	Package Marking	Transport Media	NSC Drawing
16-Pin LLP	LMH6514SQ	L6514SQ	1k Units Tape and Reel	SQA16A
	LMH6514SQX		4.5k Units Tape and Reel	

Pin Descriptions

Pin Number	Symbol	Description
Analog I/O		
6	IN+	Non-inverting analog input. Internally biased to 1.4V. Input voltage should not exceed V_{CC} or go below GND by more than 0.5V.
7	IN-	Inverting analog input. Internally biased to 1.4V. Input voltage should not exceed V_{CC} or go below GND by more than 0.5V. If using amplifier single ended this input should be capacitively coupled to ground.
15	OUT-	Open collector inverting output. This pin is an output that also requires a power source. This pin should be connected to 5V through either an RF choke or an appropriately sized inductor that can form part of a filter. See application section for details.
14	OUT+	Open collector non-inverting output. This pin is an output that also requires a power source. This pin should be connected to 5V through either an RF choke or an appropriately sized inductor that can form part of a filter. See application section for details.
16	LOAD-	Internal 200 Ω resistor connection to pin 15. This pin can be left floating for higher gain or shorted to pin 13 for lower gain and lower effective output impedance. See application section for details.
13	LOAD+	Internal 200 Ω resistor connection to pin 14. This pin can be left floating for higher gain or shorted to pin 16 for lower gain and lower effective output impedance. See application section for details.
Power		
3	V_{CC}	5V power supply pin. Use ceramic, low ESR bypass capacitors. This pin powers everything except the output stage.
5,8	GND	Ground pins. Connect to low impedance ground plane. All pin voltages are specified with respect to the voltage on these pins. The exposed thermal pad is also a ground connection.
Digital Inputs		
11,10,9	GAIN_0 to GAIN_2	Gain setting pins. See above table for gain step sizes for each pin. These pins are 3.3V CMOS logic compatible. 5V inputs may cause damage.
2	LATCH	This pin controls the function of the gain setting pins mentioned above. With LATCH in the logic HIGH state the gain is fixed and will not change. With the LATCH in the logic LOW state the gain is set by the state of the gain control pins. Any changes in gain made with the LATCH pin in the LOW state will take effect immediately. This pin is 3.3V CMOS logic compatible. 5V inputs may cause damage.
1,4,12	NC	These pins are not connected. They can be grounded or left floating.

Typical Performance Characteristics $V_{CC} = 5V$

Frequency Response All Gain Settings

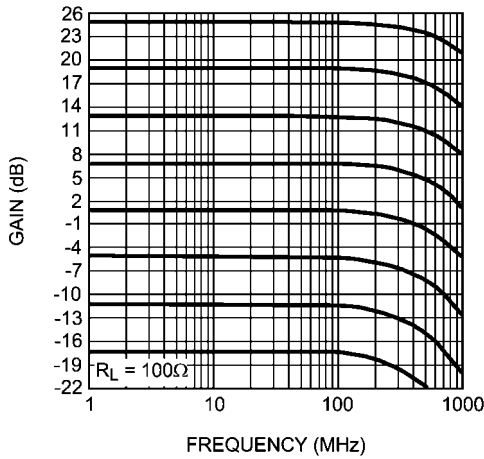

Frequency Response over Temperature, Maximum Gain

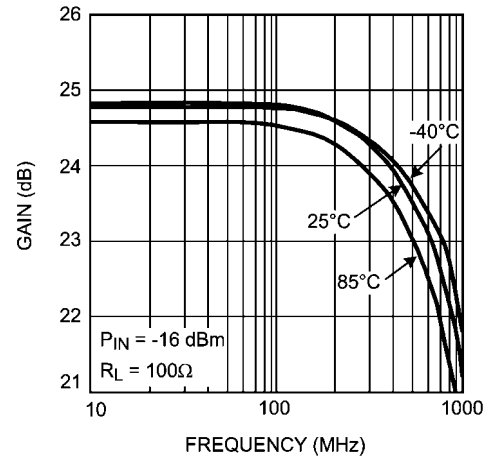

Frequency Response over Temperature, Minimum Gain

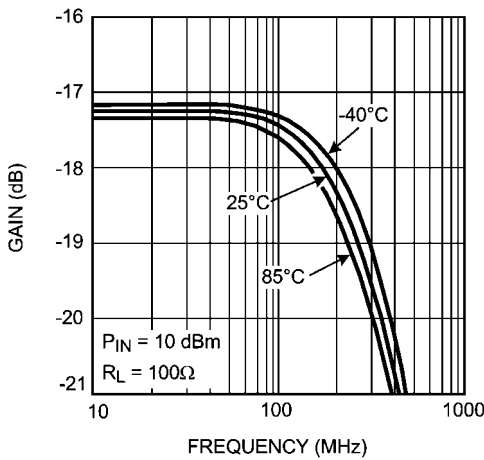

OIP3 High Gain Mode

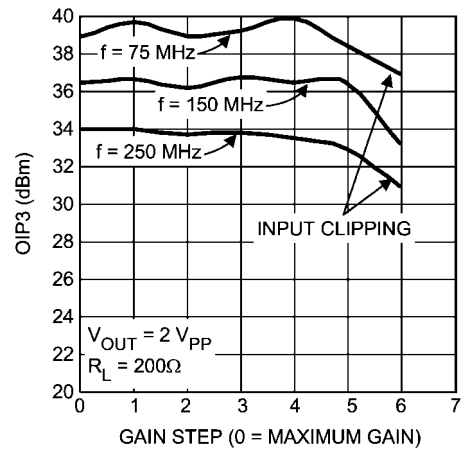

OIP3 Low Gain Mode

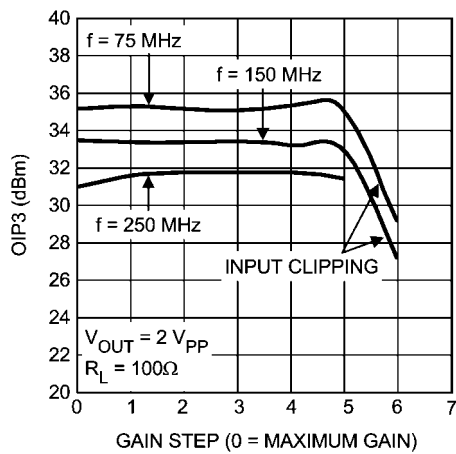

OIP3 Over Temperature

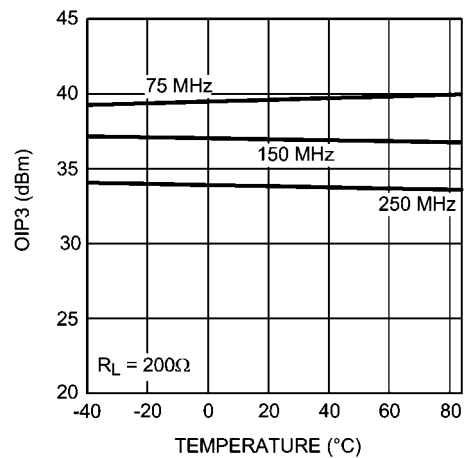

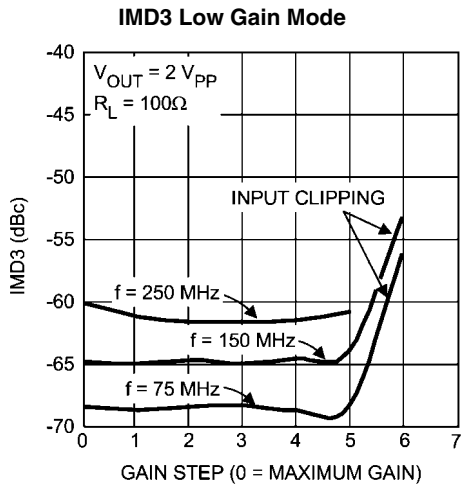

30042940

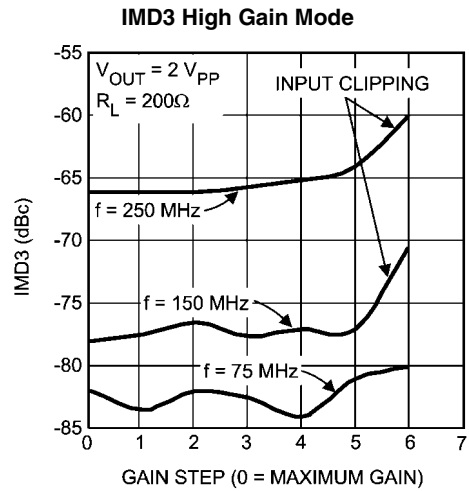

30042941

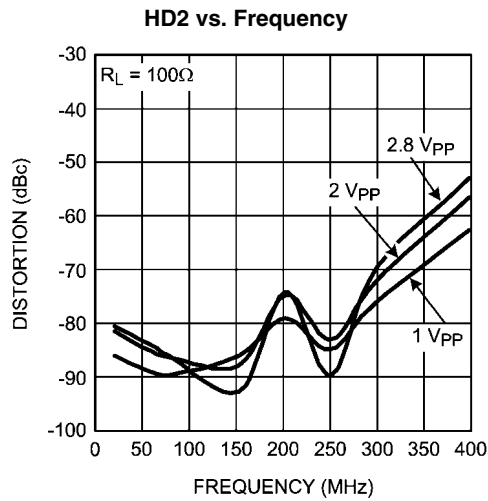

30042936

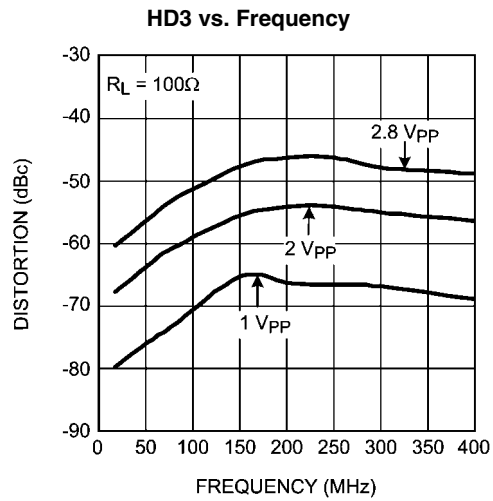

30042939

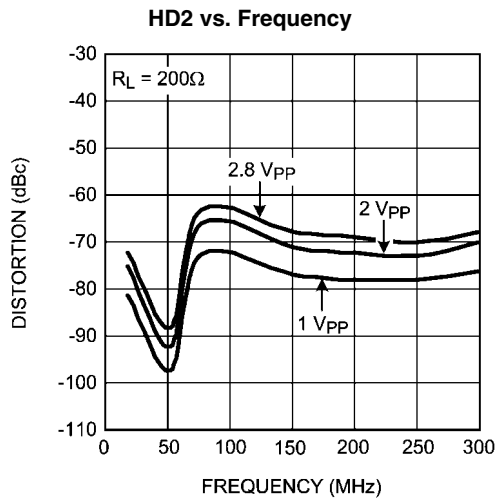

30042938

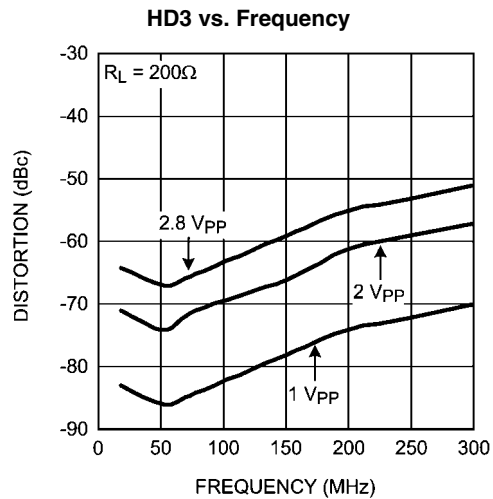

30042937

Noise Figure for All Gain Settings

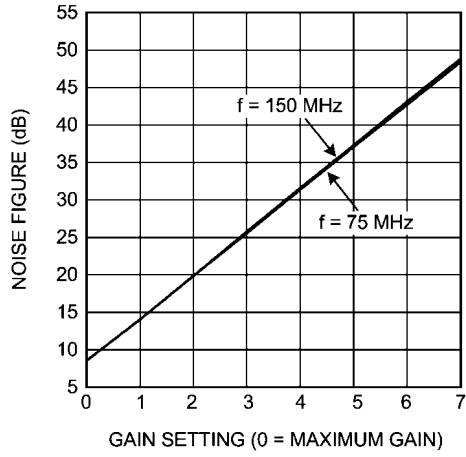

30042914

Noise Figure vs. Frequency

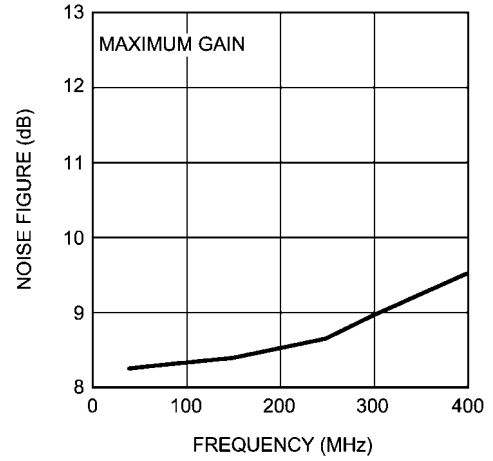

30042917

Differential Output Noise

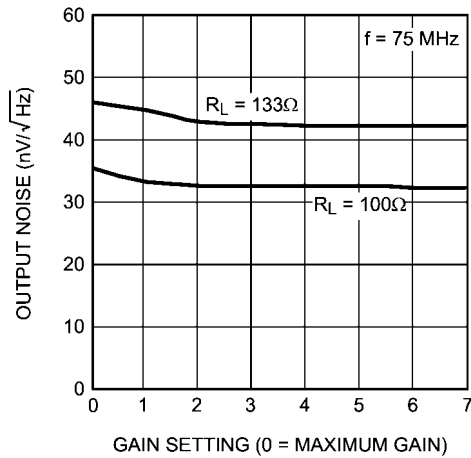

30042918

Maximum Gain vs. Supply Voltage

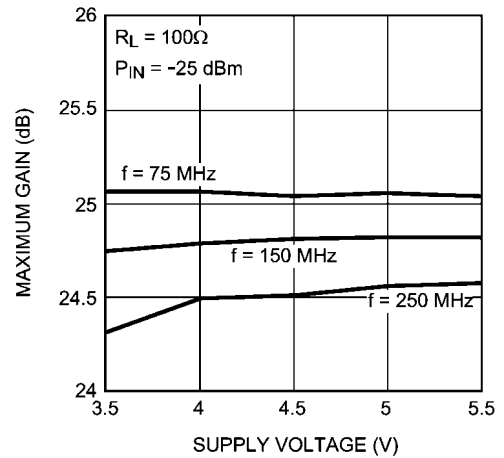

30042927

Gain vs. External Load

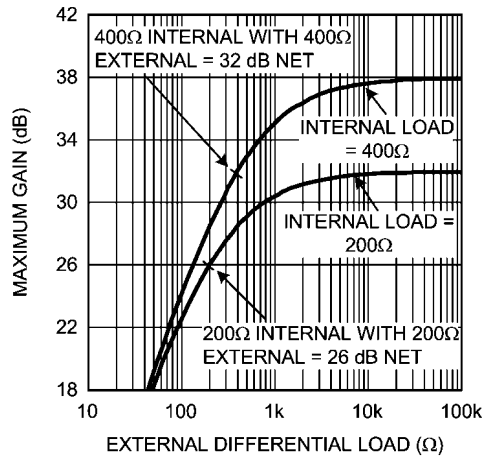

30042912

Maximum Gain over Temperature

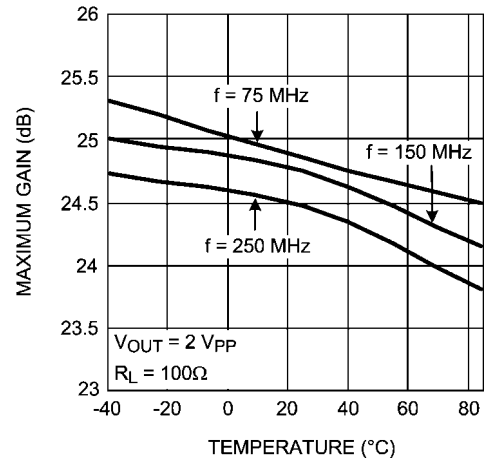

30042944

Worst Case Gain Step Error vs Frequency

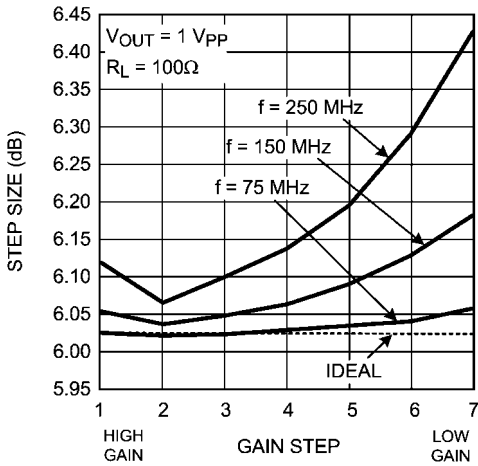

30042945

Gain Steps over Temperature

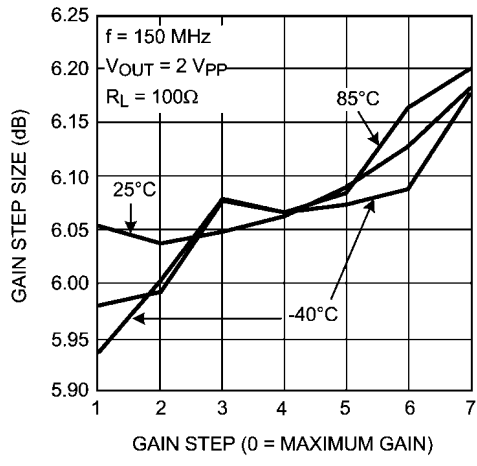

30042961

Worst Case Gain Step Error over Temperature

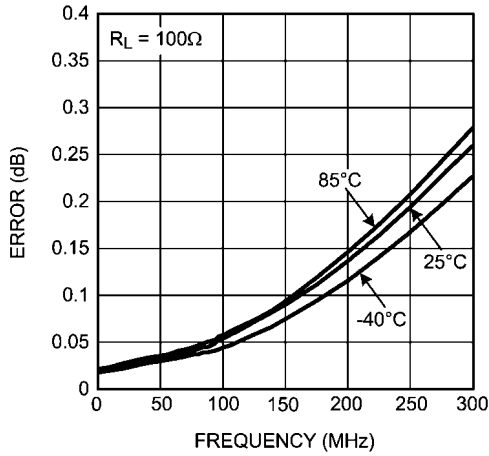

30042951

Input Impedance (S11) at Maximum Gain

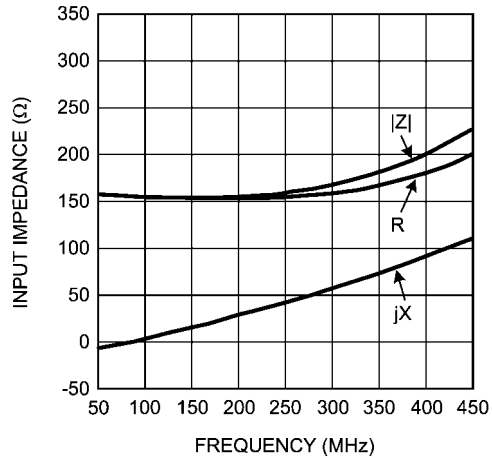

30042964

Input Impedance (S11) at Minimum Gain

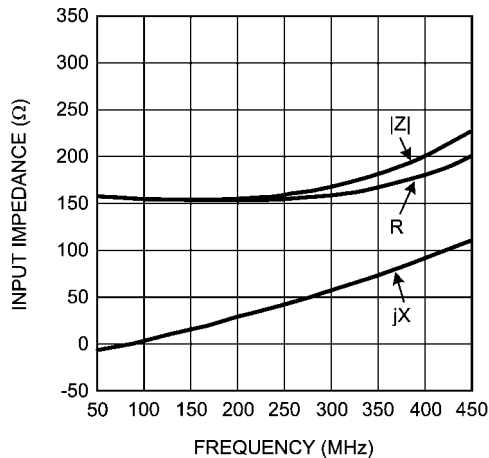

30042966

Output Impedance (S22) at Maximum Gain Low Gain Mode

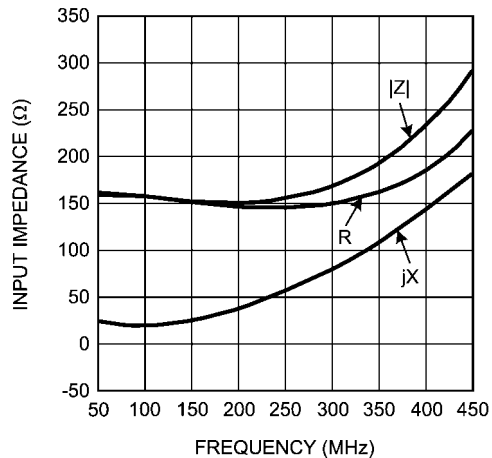

30042965

Output Impedance (S22) at Maximum Gain High Gain Mode

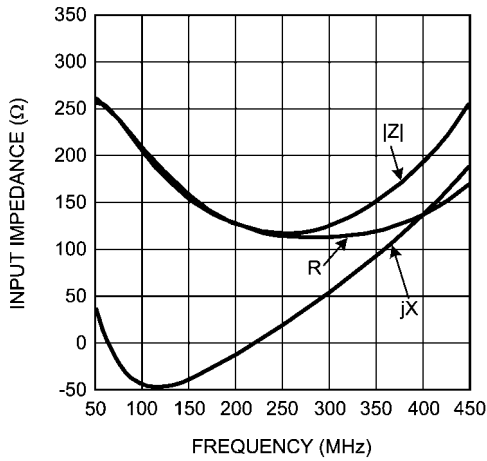

30042967

Digital Crosstalk

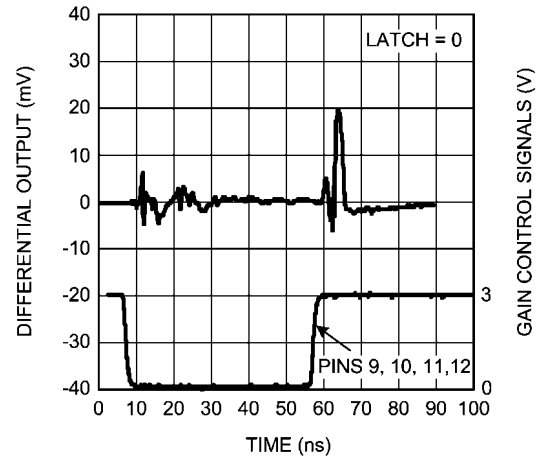

30042947

Digital Crosstalk

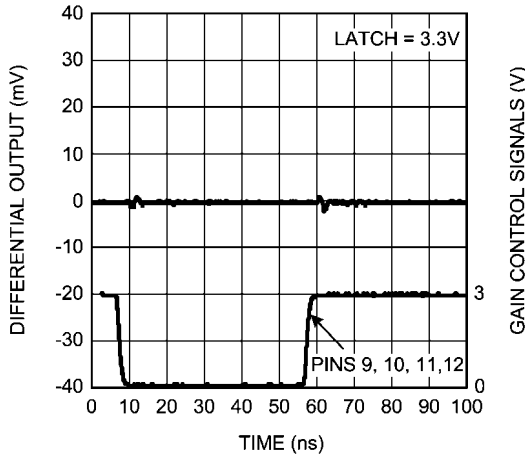

30042948

Digital Pin to Output Isolation

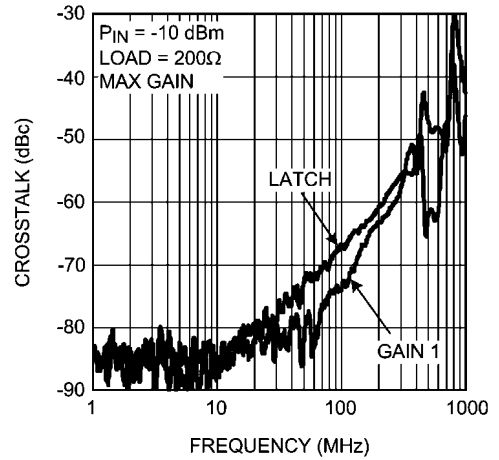

30042919

Minimum Gain to Maximum Gain Switching Using Latch Pin

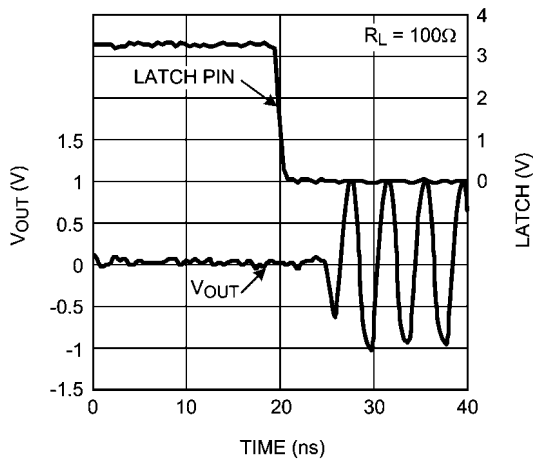

30042930

Maximum Gain to Minimum Gain Switching Using Latch Pin

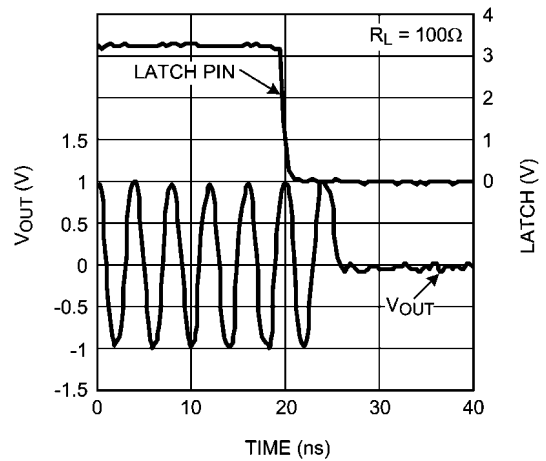

30042935

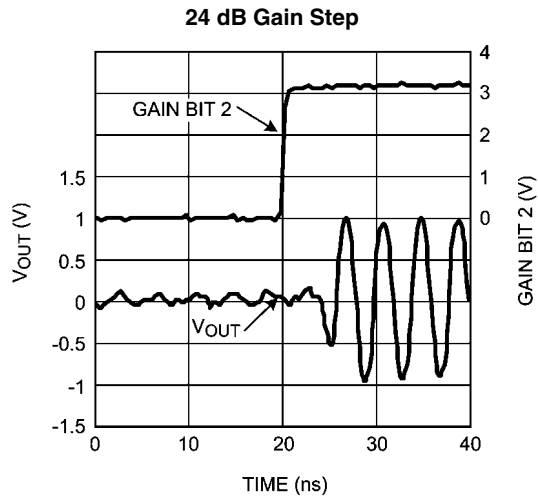

30042932

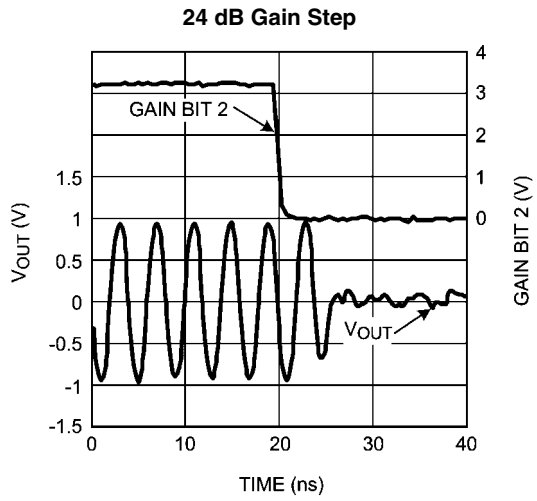

30042929

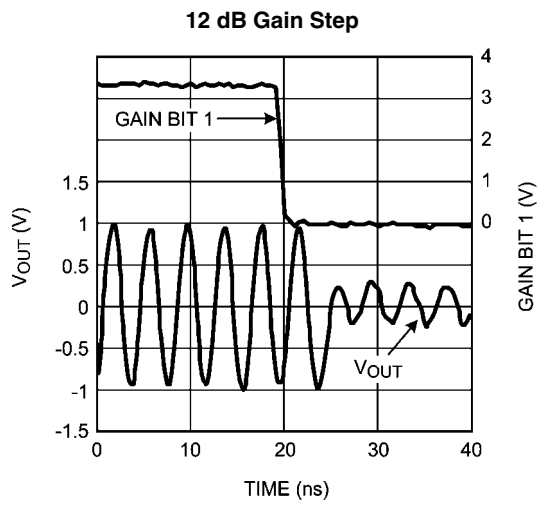

30042928

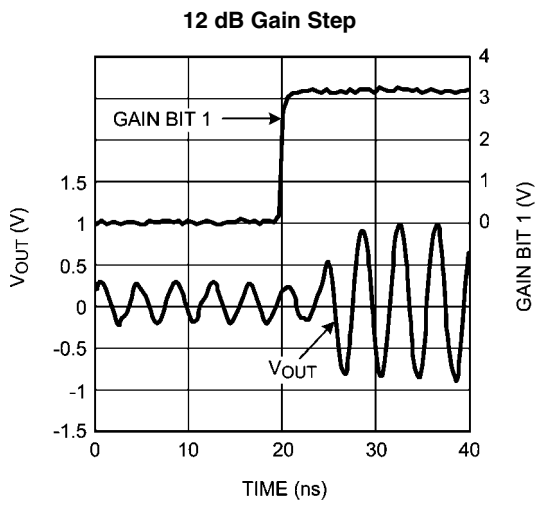

30042931

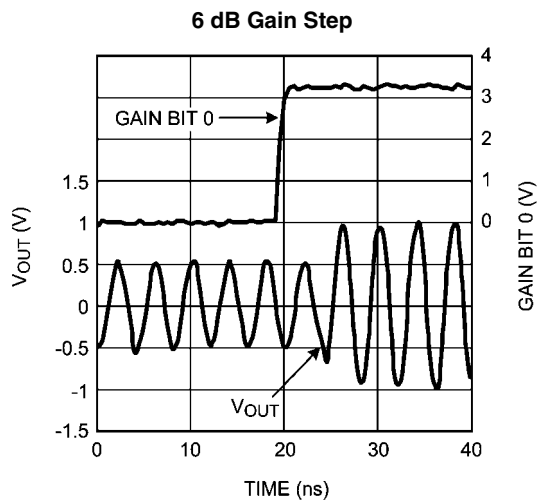

30042934

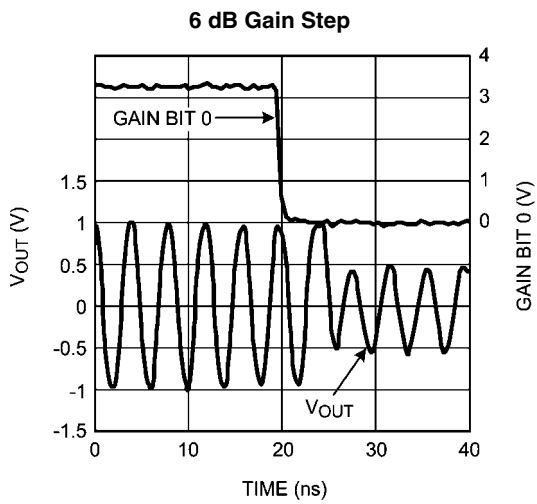

30042933

Power On Timing, Maximum Gain

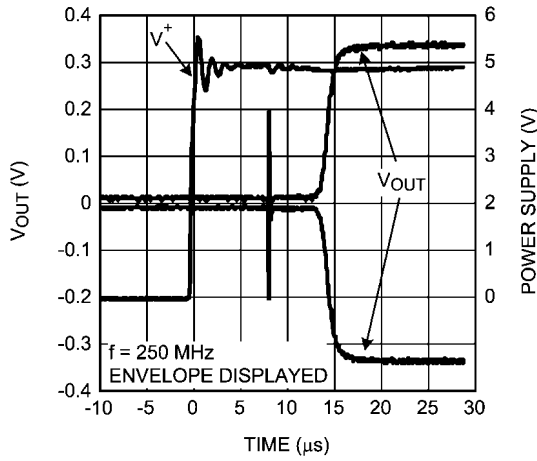

30042953

Power On Timing, Minimum Gain

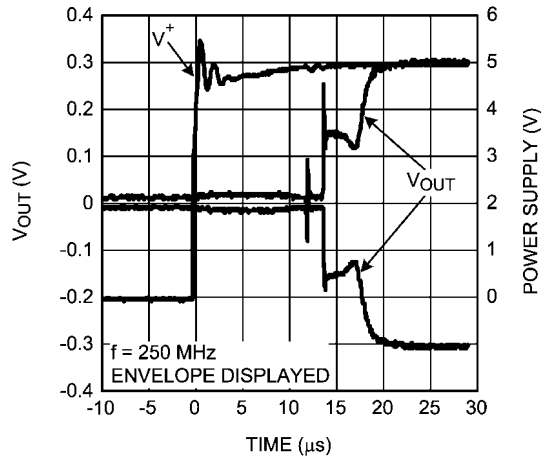

30042954

Power Off Timing, Maximum Gain

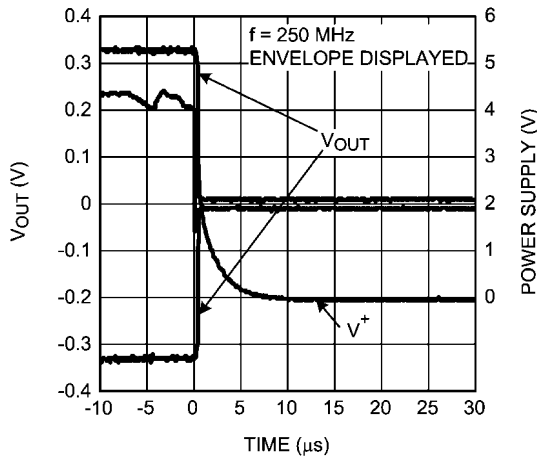

30042956

Power Off Timing, Minimum Gain

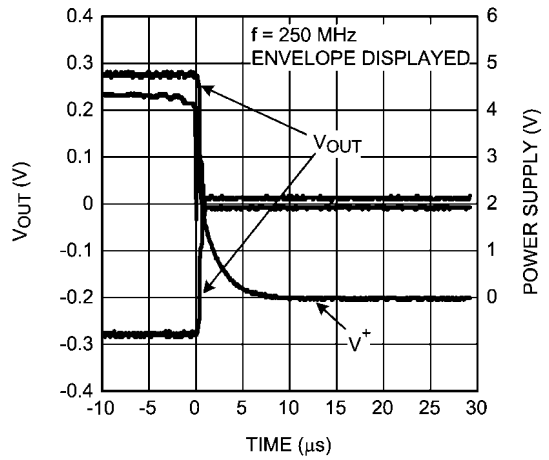

30042955

Application Information

The LMH6514 is a fully differential amplifier optimized for signal path applications up to 400 MHz. The LMH6514 has a 200Ω input. The absolute gain is load dependent, however the gain steps are always 6 dB. The LMH6514 output stage is a class A amplifier. This class A operation results in excellent distortion and linearity characteristics. This makes the LMH6514 ideal for voltage amplification and an ideal ADC driver where high linearity is necessary.

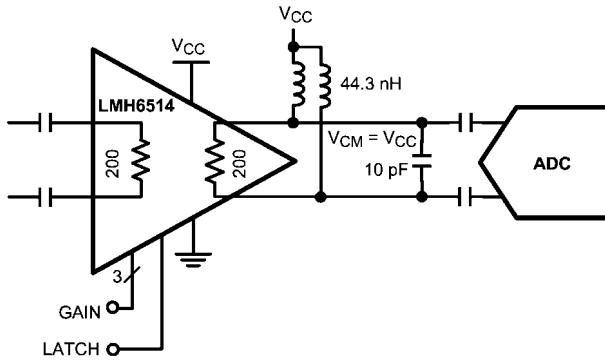

30042903

FIGURE 1. LMH6514 Typical Application

The LMH6514 output common mode should be set carefully. Using inductors to set the output common mode is one preferred method and will give maximum output swing. AC coupling of the output is recommended. The inductors mentioned above will shift the idling output common mode to the positive supply. Also, with the inductors, the output voltage can exceed the supply voltage. Other options for setting the output common mode require supply voltages above 5V. If using a supply higher than 5V care should be taken to make sure the output common mode does not exceed the 5.25V supply rating.

It is also important to note the maximum voltage limits for the OUT+ and OUT- pins, which is 6.4V. When using inductors these pins will experience voltage swings beyond the supply voltage. With a 5V output common mode operating point this makes the effective maximum swing $5.6 V_{PP}$ differential. System calibration and automatic gain control algorithms should be tailored to avoid exceeding this limit. Figure 2 shows how output voltage and output common mode add together and approach the maximum output voltage.

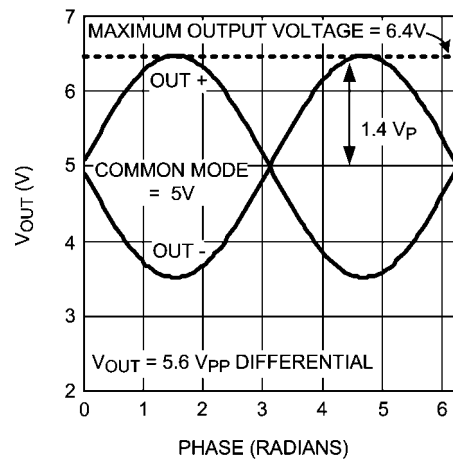

30042962

FIGURE 2. Output Voltage with Respect to the Output Common Mode

In order to help with system design National Semiconductor offers the ADC14V155KDRB High IF Receiver reference design board. This board combines the LMH6514 DVGA with the ADC14V155 ADC and provides a ready made solution for many IF receiver applications. Using an IF frequency of 169 MHz it achieves a small signal SNR of 72 dBFS and an SFDR of greater than 90 dBFS. Large signal measurements show an SNR of 68 dBFS and an SFDR of 77 dBFS. The High IF Receiver board also features the LMK03000 low-jitter precision clock conditioner.

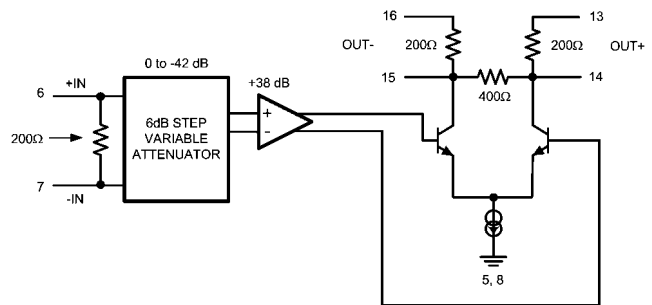

30042911

FIGURE 3. LMH6514 Block Diagram

INPUT CHARACTERISTICS

The LMH6514 input impedance is set by internal resistors to a nominal 200Ω . Process variations will result in a range of values as shown in the *5V Electrical Characteristics* table. At higher frequencies parasitics will start to impact the impedance. This characteristic will also depend on board layout and should be verified on the customer's system board.

At maximum gain the digital attenuator is set to 0 dB and the input signal will be much smaller than the output. At minimum gain the output is 4 dB or more smaller than the input. In this configuration the input signal size may limit the amplifier output amplitude, depending on the output configuration and the desired output signal voltage. The input signal cannot swing more than 0.5V below the negative supply voltage (normally 0V) nor should it exceed the positive supply voltage. The input signal will clip and cause severe distortion if it is too large. Because the input stage self biases to approximately 1.4V the lower supply voltage will impose the limit for input voltage

swing. To drive larger input signals the input common mode can be forced higher than 1.4V to allow for more swing. An input common mode of 2.0V will allow an 8 V_{PP} maximum input signal. The trade off for input signal swing is that as the input common mode is shifted away from the 1.4V internal bias point the distortion performance will suffer slightly.

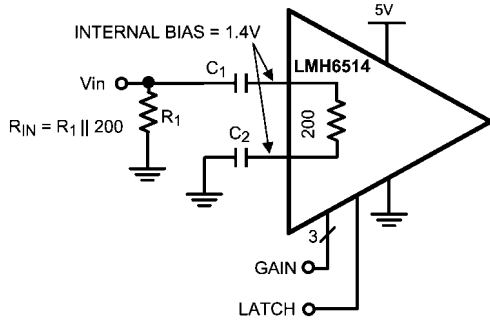

FIGURE 4. Single Ended Input (Note capacitor on grounded input)

At the frequencies where the LMH6514 is the most useful the input impedance is not 200 Ω and it may not be purely resistive. For many AC coupled applications the impedance can be easily changed using LC circuits to transform the actual impedance to the desired impedance.

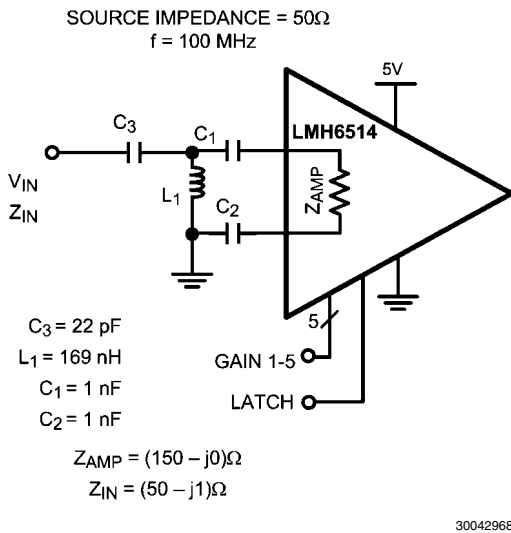

FIGURE 5. Single Ended Input with LC Matching

As shown in *Figure 5* a single ended 50Ω source is matched to the LMH6514 input at 100 MHz. The loss in this circuit is related to the parasitic resistance in the inductor and capacitor and the bandwidth is related to the loaded Q of the circuit. Since the Q, at 1.4 is quite low, the bandwidth is very wide. (59 MHz 0.3 dB bandwidth). The input match of this circuit is quite good. It converts the Z_{AMP} of the amplifier, which is (150 +j0)Ω to (50+j1)Ω. The benefit of LC matching circuits over a transformer is the ability to match ratios that are not commonly found on transformers and also the ability to neutralize reactance to present a purely resistive load to the voltage source.

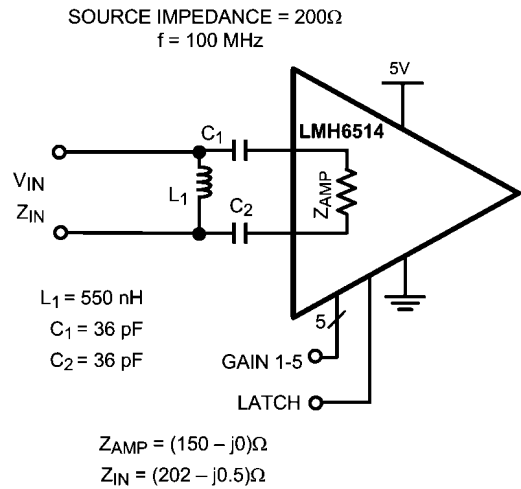

FIGURE 6. Differential 200Ω LC Conversion Circuit

In *Figure 6* the input source resistance is 200Ω differential. Here the desired input impedance is higher than the amplifier input impedance, and is differential as well. The amplifier impedance of (150-j0)Ω is increased to (202-j0.5)Ω. For an easy way to calculate the L and C circuit values there are several options for online tools or down-loadable programs. The following tool might be helpful.

<http://www.circuitsage.com/matching/matcher2.html>

Excel can also be used for simple circuits; however, the “Analysis ToolPak” add-in must be installed to calculate complex numbers.

OUTPUT CHARACTERISTICS

The LMH6514 has the option of two different output configurations. The LMH6514 is an open collector topology. As shown in *Figure 11* each output has an on chip 200Ω pull up resistor. In addition there is an internal 400Ω resistor between the two outputs. This results in a 200Ω or a 400Ω differential load in parallel with the external load. The 400Ω option is the high gain option and the 200Ω provides for less gain. The 200Ω configuration is recommended unless more gain is required.

The output common mode of the LMH6514 must be set by external components. Most applications will benefit from the use of inductors on the output stage. In particular, the 400Ω option as shown in *Figure 12* will require inductors in order to be able to develop an output voltage. The 200Ω option as shown in *Figure 13* or *Figure 14* will also require inductors since the voltage drop due to the on chip 200Ω resistors will saturate the output transistors. It is also possible to use resistors and high voltage power supplies to set the output common mode. This operation is not recommended, unless it is necessary to DC couple the output. If DC coupling is required the input common mode and output common mode voltages must be taken into account.

Maximum bandwidth with the LMH6514 is achieved by using the low gain, low impedance output option and using a low load resistance. With an effective load of 67Ω a bandwidth of nearly a 1 GHz can be realized. As the effective resistance on the output stage goes up the capacitance of the board traces and amplifier output stage limit bandwidth in a roughly linear fashion. At an output impedance of 100Ω the bandwidth is down to 600 MHz, and at 200Ω the bandwidth is 260 MHz.

For this reason driving very high impedance loads is not recommended.

Although bandwidth goes down with higher values of load resistance, the distortion performance improves and gain increases. The LMH6514 has a common emitter Class A output stage and minimizing the amount of current swing in the output devices improves distortion substantially.

The LMH6514 output stage is powered through the collectors of the output transistors. Power for the output stage is fed through inductors and the reactance of the inductors allows the output voltage to develop. In *Figure 1* the inductors are shown with a value of 44.4 nH. The value of the inductors used will be different for different applications. In *Figure 1* the inductors have been chosen to resonate with the ADC and the load capacitor to provide a weak band pass filter effect. For broad band applications higher value inductors will allow for better low frequency operation. However, large valued inductors will reduce high frequency performance, particularly inductors of small physical sizes like 0603 or smaller. Larger inductors will tend to perform better than smaller ones of the same value even for narrow band applications. This is because the larger inductors will have a lower DC resistance and less inter-winding capacitance and hence a higher Q and a higher self resonance frequency. The self resonance frequency should be higher than any desired signal content by at least a factor of 2. Another consideration is that the power inductors and the filter inductors need to be placed on the circuit board such that their magnetic fields do not cause coupling. Mutual coupling of inductors can compromise filter characteristics and lead to unwanted distortion products.

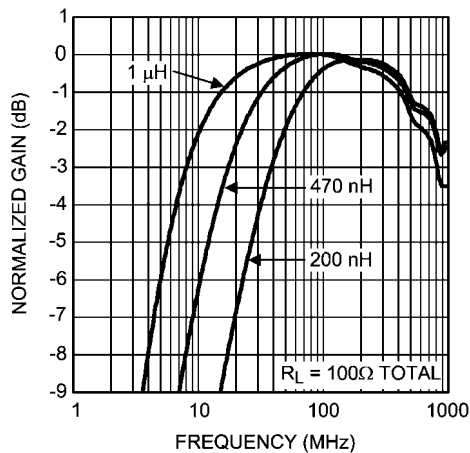

30042915

FIGURE 7. Bandwidth Changes Due to Different Inductor Values

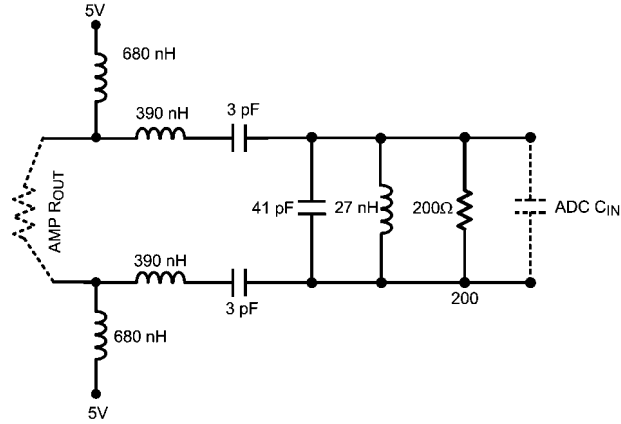

30042906

FIGURE 8. Gain vs. External Load

DIGITAL CONTROL

The LMH6514 has eight gain settings covering a range of 42 dB. To avoid undesirable signal transients the LMH6514 should be powered on at the minimum gain state (all logic input pins at 0V). The LMH6514 has a 3-bit gain control bus as well as a Latch pin. When the Latch pin is low, data from the gain control pins is immediately sent to the gain circuit (i.e. gain is changed immediately). When the Latch pin transitions high the current gain state is held and subsequent changes to the gain set pins are ignored. To minimize gain change glitches multiple gain control pins should not change while the latch pin is low. In order to achieve the very fast gain step switching time of 5 ns the internal gain change circuit is very fast. Gain glitches could result from timing skew between the gain set bits. This is especially the case when a small gain change requires a change in state of three or more gain control pins. If continuous gain control is desired the Latch pin can be tied to ground. This state is called transparent mode and the gain pins are always active. In this state the timing of the gain pin logic transitions should be planned carefully to avoid undesirable transients.

The LMH6514 was designed to interface with 3.3V CMOS logic circuits. If operation with 5V logic is required a simple voltage divider at each logic pin will allow for this. To properly terminate 100Ω transmission lines a divider with a 66.5Ω resistor to ground and a 33.2Ω series resistor will properly terminate the line as well as give the 3.3V logic levels. Care should be taken not to exceed the 3.6V absolute maximum voltage rating of the logic pins.

EXPOSED PAD LLP PACKAGE

The LMH6514 is packaged in a thermally enhanced package. The exposed pad is connected to the GND pins. It is recommended, but not necessary, that the exposed pad be connected to the supply ground plane. In any case, the thermal dissipation of the device is largely dependent on the attachment of this pad. The exposed pad should be attached to as much copper on the circuit board as possible, preferably external copper. However, it is also very important to maintain good high speed layout practices when designing a system board. Please refer to the LMH6514 evaluation board for suggested layout techniques.

Package information is available on the National web site.
<http://www.national.com/packaging/folders/sqa16a.html>

INTERFACING TO ADC

The LMH6514 was designed to be used with high speed ADCs such as the ADC14155. As shown in the Typical Application on page 1, AC coupling provides the best flexibility especially for IF sub-sampling applications. Any resistive networks on the output will also cause a gain loss because the output signal is developed across the output resistors. The chart *Maximum Gain vs. External Load* shows the change in gain when an external load is added.

The inputs of the LMH6514 will self bias to the optimum voltage for normal operation. The internal bias voltage for the inputs is approximately 1.4V. In most applications the LMH6514 input will need to be AC coupled.

The output common mode voltage is not self biasing, it needs to be pulled up to the positive supply rail with external inductors as shown in *Figure 1*. This gives the LMH6514 the capability for large signal swings with very low distortion on a single 5V supply. The internal load resistors provide the LMH6514 with very consistent gain.

A unique internal architecture allows the LMH6514 to be driven by either a differential or single ended source. If driving the LMH6514 single ended the unused input should be terminated to ground with a 0.01 μF capacitor. Directly shorting the unused input to ground will disrupt the internal bias circuitry and will result in poor performance.

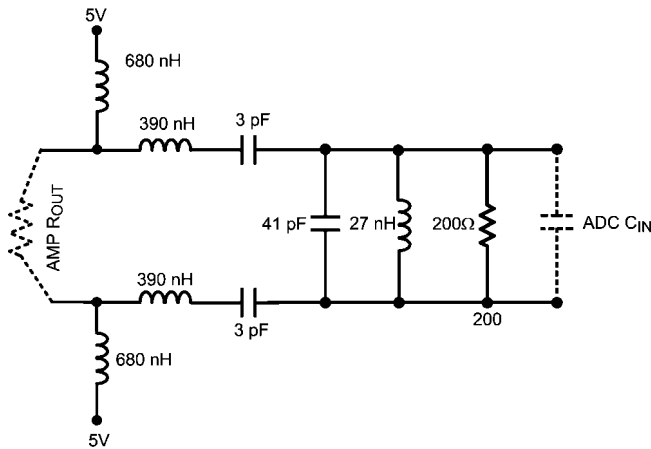

30042906

**FIGURE 9. Bandpass Filter
Center Frequency is 140 MHz with a 20 MHz Bandwidth
Designed for 200 Ω Impedance**

ADC Noise Filter

Below is a filter schematic and a table of values for some common IF frequencies. The filter shown below offers a good compromise between bandwidth, noise rejection and cost. This filter topology is the same as is used on the AD-C14V155KDRB High IF Receiver reference design board. This filter topology works best with the 12 and 14 bit sub-sampling analog to digital converters shown in the *Compatible High Speed Analog to Digital Converters* table.

Filter Component Values

Filter Component Values					
	Fc	75 MHz	140 MHz	170 MHz	250 MHz
	BW	40 MHz	20 MHz	25 MHz	Narrow Band
Components	L1, L2	10 μH	10 μH	10 μH	10 μH
	L3, L4	390 nH	390 nH	560 nH	—
	C1, C2	10 pF	3 pF	1.4 pF	47 pF
	C3	22 pF	41 pF	32 pF	11 pF
	L5	220 nH	27 nH	30 nH	22 nH
	R1, R2	100	200	100	499

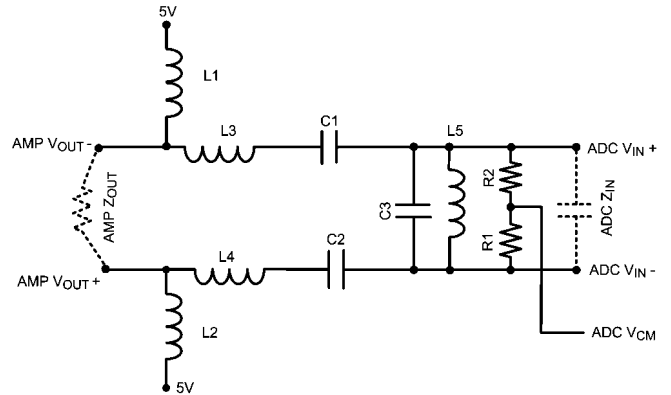

30042913

FIGURE 10. Sample Filter

POWER SUPPLIES

As shown in *Figure 11*, the LMH6514 has a number of options for power supply connections on the output pins. Pin 3 (V_{CC}) is always connected. The output stage can be connected as shown in *Figure 12*, *Figure 13*, and *Figure 14*. The supply voltage range for V_{CC} is 4V to 5.25V. A 5V supply provides the best performance while lower supplies will result in less power consumption. Power supply regulation of 2.5% or better is advised.

Of special note is that the digital circuits are powered from an internal supply voltage of 3.3V. The logic pins should not be driven above the absolute maximum value of 3.6V. See the Digital Control section for details.

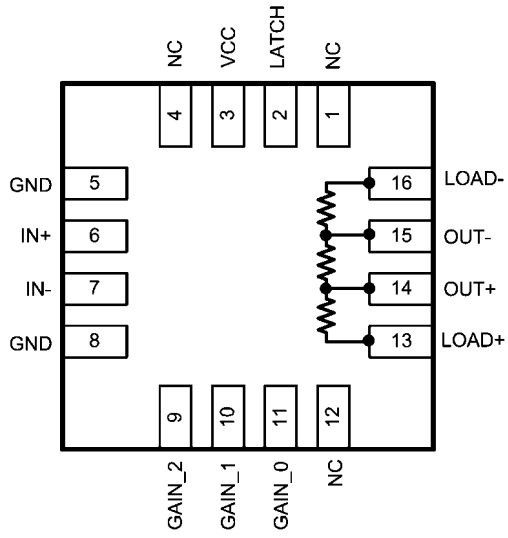

30042902

FIGURE 11. Internal Load Resistors

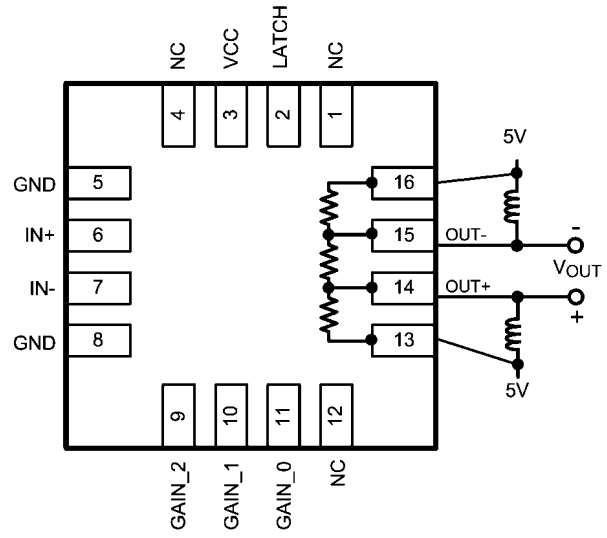

30042909

FIGURE 13. Using Low Gain Mode (200Ω Load)

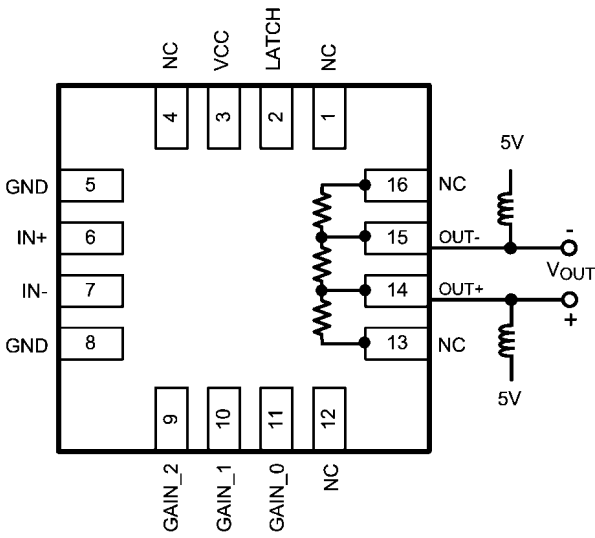

30042908

FIGURE 12. Using High Gain Mode (400Ω Load)

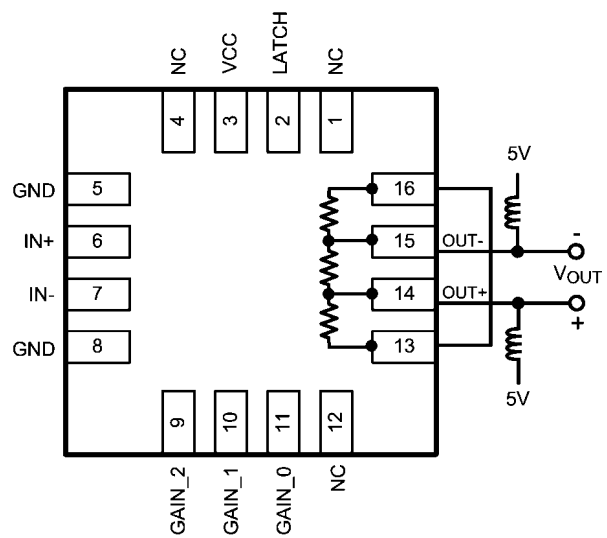

30042910

FIGURE 14. Alternate Connection for Low Gain Mode (200Ω Load)

Compatible High Speed Analog to Digital Converters

Product Number	Max Sampling Rate (MSPS)	Resolution	Channels
ADC12L063	62	12	SINGLE
ADC12DL065	65	12	DUAL
ADC12L066	66	12	SINGLE
ADC12DL066	66	12	DUAL
CLC5957	70	12	SINGLE
ADC12L080	80	12	SINGLE
ADC12DL080	80	12	DUAL
ADC12C080	80	12	SINGLE
ADC12C105	105	12	SINGLE
ADC12C170	170	12	SINGLE
ADC12V170	170	12	SINGLE
ADC14C080	80	14	SINGLE
ADC14C105	105	14	SINGLE
ADC14DS105	105	14	DUAL
ADC14I155	155	14	SINGLE
ADC14V155	155	14	SINGLE
ADC08D500	500	8	DUAL
ADC08500	500	8	SINGLE
ADC08D1000	1000	8	DUAL
ADC081000	1000	8	SINGLE
ADC08D1500	1500	8	DUAL
ADC081500	1500	8	SINGLE
ADC08(B)3000	3000	8	SINGLE
ADC08L060	60	8	SINGLE
ADC08060	60	8	SINGLE
ADC10DL065	65	10	DUAL
ADC10065	65	10	SINGLE
ADC10080	80	10	SINGLE
ADC08100	100	8	SINGLE
ADCS9888	170	8	SINGLE
ADC08(B)200	200	8	SINGLE
ADC11C125	125	11	SINGLE
ADC11C170	170	11	SINGLE

Physical Dimensions inches (millimeters) unless otherwise noted

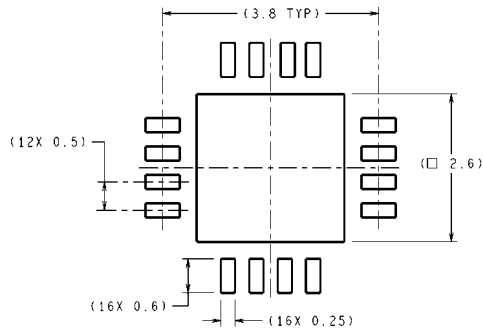

RECOMMENDED LAND PATTERN

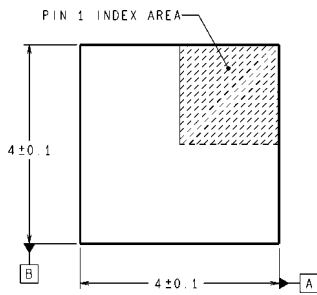

DIMENSIONS ARE IN MILLIMETERS
DIMENSIONS IN () FOR REFERENCE ONLY

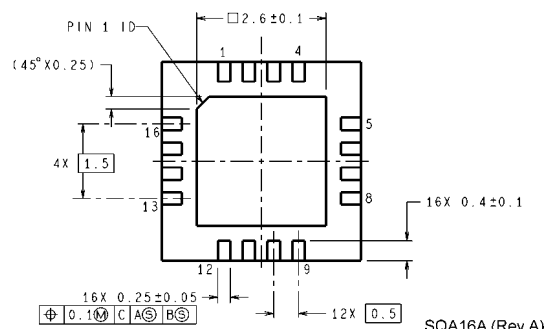
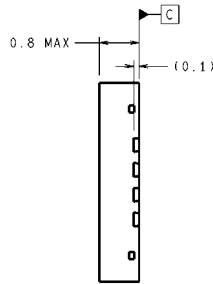

SQA16A (Rev A)

16-Pin Package
NS Package Number SQA16A

Notes

For more National Semiconductor product information and proven design tools, visit the following Web sites at:

Products		Design Support	
Amplifiers	www.national.com/amplifiers	WEBENCH	www.national.com/webench
Audio	www.national.com/audio	Analog University	www.national.com/AU
Clock Conditioners	www.national.com/timing	App Notes	www.national.com/appnotes
Data Converters	www.national.com/adc	Distributors	www.national.com/contacts
Displays	www.national.com/displays	Green Compliance	www.national.com/quality/green
Ethernet	www.national.com/ethernet	Packaging	www.national.com/packaging
Interface	www.national.com/interface	Quality and Reliability	www.national.com/quality
LVDS	www.national.com/lvds	Reference Designs	www.national.com/refdesigns
Power Management	www.national.com/power	Feedback	www.national.com/feedback
Switching Regulators	www.national.com/switchers		
LDOs	www.national.com/ldo		
LED Lighting	www.national.com/led		
PowerWise	www.national.com/powerwise		
Serial Digital Interface (SDI)	www.national.com/sdi		
Temperature Sensors	www.national.com/tempsensors		
Wireless (PLL/VCO)	www.national.com/wireless		

THE CONTENTS OF THIS DOCUMENT ARE PROVIDED IN CONNECTION WITH NATIONAL SEMICONDUCTOR CORPORATION ("NATIONAL") PRODUCTS. NATIONAL MAKES NO REPRESENTATIONS OR WARRANTIES WITH RESPECT TO THE ACCURACY OR COMPLETENESS OF THE CONTENTS OF THIS PUBLICATION AND RESERVES THE RIGHT TO MAKE CHANGES TO SPECIFICATIONS AND PRODUCT DESCRIPTIONS AT ANY TIME WITHOUT NOTICE. NO LICENSE, WHETHER EXPRESS, IMPLIED, ARISING BY ESTOPPEL OR OTHERWISE, TO ANY INTELLECTUAL PROPERTY RIGHTS IS GRANTED BY THIS DOCUMENT.

TESTING AND OTHER QUALITY CONTROLS ARE USED TO THE EXTENT NATIONAL DEEMS NECESSARY TO SUPPORT NATIONAL'S PRODUCT WARRANTY. EXCEPT WHERE MANDATED BY GOVERNMENT REQUIREMENTS, TESTING OF ALL PARAMETERS OF EACH PRODUCT IS NOT NECESSARILY PERFORMED. NATIONAL ASSUMES NO LIABILITY FOR APPLICATIONS ASSISTANCE OR BUYER PRODUCT DESIGN. BUYERS ARE RESPONSIBLE FOR THEIR PRODUCTS AND APPLICATIONS USING NATIONAL COMPONENTS. PRIOR TO USING OR DISTRIBUTING ANY PRODUCTS THAT INCLUDE NATIONAL COMPONENTS, BUYERS SHOULD PROVIDE ADEQUATE DESIGN, TESTING AND OPERATING SAFEGUARDS.

EXCEPT AS PROVIDED IN NATIONAL'S TERMS AND CONDITIONS OF SALE FOR SUCH PRODUCTS, NATIONAL ASSUMES NO LIABILITY WHATSOEVER, AND NATIONAL DISCLAIMS ANY EXPRESS OR IMPLIED WARRANTY RELATING TO THE SALE AND/OR USE OF NATIONAL PRODUCTS INCLUDING LIABILITY OR WARRANTIES RELATING TO FITNESS FOR A PARTICULAR PURPOSE, MERCHANTABILITY, OR INFRINGEMENT OF ANY PATENT, COPYRIGHT OR OTHER INTELLECTUAL PROPERTY RIGHT.

LIFE SUPPORT POLICY

NATIONAL'S PRODUCTS ARE NOT AUTHORIZED FOR USE AS CRITICAL COMPONENTS IN LIFE SUPPORT DEVICES OR SYSTEMS WITHOUT THE EXPRESS PRIOR WRITTEN APPROVAL OF THE CHIEF EXECUTIVE OFFICER AND GENERAL COUNSEL OF NATIONAL SEMICONDUCTOR CORPORATION. As used herein:

Life support devices or systems are devices which (a) are intended for surgical implant into the body, or (b) support or sustain life and whose failure to perform when properly used in accordance with instructions for use provided in the labeling can be reasonably expected to result in a significant injury to the user. A critical component is any component in a life support device or system whose failure to perform can be reasonably expected to cause the failure of the life support device or system or to affect its safety or effectiveness.

National Semiconductor and the National Semiconductor logo are registered trademarks of National Semiconductor Corporation. All other brand or product names may be trademarks or registered trademarks of their respective holders.

Copyright© 2008 National Semiconductor Corporation

For the most current product information visit us at www.national.com



National Semiconductor Americas Technical Support Center
 Email: new.feedback@nsc.com
 Tel: 1-800-272-9959

National Semiconductor Europe Technical Support Center
 Email: europe.support@nsc.com
 German Tel: +49 (0) 180 5010 771
 English Tel: +44 (0) 870 850 4288

National Semiconductor Asia Pacific Technical Support Center
 Email: ap.support@nsc.com

National Semiconductor Japan Technical Support Center
 Email: jpn.feedback@nsc.com