

LMH6622

Dual Wideband, Low Noise, 160MHz, Operational Amplifiers

General Description

The LMH6622 is a dual high speed voltage feedback operational amplifier specifically optimized for low noise. A voltage noise specification of $1.6\text{nV}/\sqrt{\text{Hz}}$, a current noise specification $1.5\text{pA}/\sqrt{\text{Hz}}$, a bandwidth of 160MHz, and a harmonic distortion specification that exceeds 90dBc combine to make the LMH6622 an ideal choice for the receive channel amplifier in ADSL, VDSL, or other xDSL designs. The LMH6622 operates from $\pm 2.5\text{V}$ to $\pm 6\text{V}$ in dual supply mode and from $+5\text{V}$ to $+12\text{V}$ in single supply configuration. The LMH6622 is stable for $A_V \geq 2$ or $A_V \leq -1$. The fabrication of the LMH6622 on National Semiconductor's advanced VIP10 process enables excellent (160MHz) bandwidth at a current consumption of only 4.3mA/amplifier. Packages for this dual amplifier are the 8-lead SOIC and the 8-lead MSOP.

Features

$V_S = \pm 6\text{V}$, $T_A = 25^\circ\text{C}$, Typical values unless specified

■ Bandwidth ($A_V = +2$)	160MHz
■ Supply Voltage Range	$\pm 2.5\text{V}$ to $\pm 6\text{V}$ +5V to +12
■ Slew rate	85V/ μs
■ Supply current	4.3mA/amp
■ Input common mode voltage	-4.75V to $+5.7\text{V}$
■ Output Voltage Swing ($R_L = 100\Omega$)	$\pm 4.6\text{V}$
■ Input voltage noise	$1.6\text{nV}/\sqrt{\text{Hz}}$
■ Input current noise	$1.5\text{pA}/\sqrt{\text{Hz}}$
■ Linear output current	90mA
■ Excellent harmonic distortion	90dBc

Applications

- xDSL receiver
- Low noise instrumentation front end
- Ultrasound preamp
- Active filters
- Cellphone basestation

xDSL Analog Front End

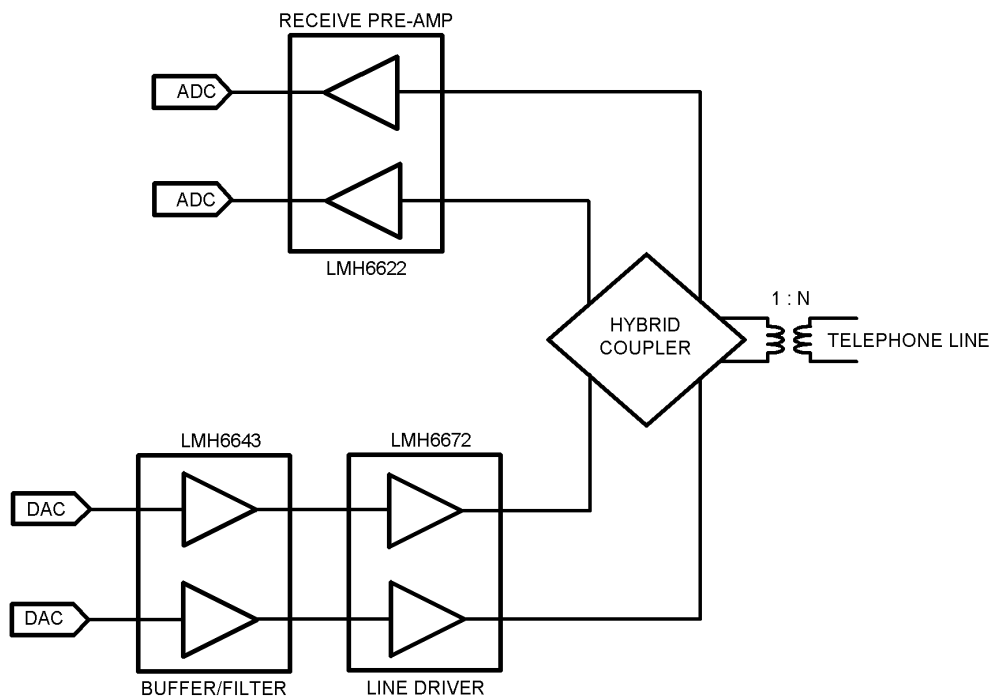

20029226

Absolute Maximum Ratings (Note 1)

If Military/Aerospace specified devices are required, please contact the National Semiconductor Sales Office/Distributors for availability and specifications.

ESD Tolerance

Human Body Model	2kV (Note 2)
Machine Model	200V (Note 2)
V_{IN} Differential	$\pm 1.2V$
Supply Voltage ($V^+ - V^-$)	13.2V
Voltage at Input Pins	$V^+ +0.5V, V^- -0.5V$
Soldering Information	
Infrared or Convection (20 sec)	235°C

Wave Soldering (10 sec) 260°C

Storage Temperature Range -65°C to +150°C

Junction Temperature (Note 4) +150°C

Operating Ratings (Note 1)

Supply Voltage ($V^+ - V^-$)	$\pm 2.25V$ to $\pm 6V$
Junction Temperature Range (Note 3), (Note 4)	-40°C to +85°C
Package Thermal Resistance (Note 4) (θ_{JA})	
8-pin SOIC	166°C/W
8-pin MSOP	211°C/W

 $\pm 6V$ Electrical Characteristics

Unless otherwise specified, $T_J = 25^\circ C$, $V^+ = 6V$, $V^- = -6V$, $V_{CM} = 0V$, $A_V = +2$, $R_F = 500\Omega$, $R_L = 100\Omega$. **Boldface** limits apply at the temperature extremes.

Symbol	Parameter	Conditions	Min (Note 6)	Typ (Note 5)	Max (Note 6)	Units
Dynamic Performance						
f_{CL}	-3dB BW	$V_O = 200mV_{PP}$		160		MHz
$BW_{0.1dB}$	0.1dB Gain Flatness	$V_O = 200mV_{PP}$		30		MHz
SR	Slew Rate (Note 8)	$V_O = 2V_{PP}$		85		V/ μs
TS	Settling Time	$V_O = 2V_{PP}$ to $\pm 0.1\%$		40		ns
		$V_O = 2V_{PP}$ to $\pm 1.0\%$		35		
Tr	Rise Time	$V_O = 0.2V$ Step, 10% to 90%		2.3		ns
Tf	Fall Time	$V_O = 0.2V$ Step, 10% to 90%		2.3		ns
Distortion and Noise Response						
e_n	Input Referred Voltage Noise	$f = 100kHz$		1.6		nV/ \sqrt{Hz}
i_n	Input Referred Current Noise	$f = 100kHz$		1.5		pA/ \sqrt{Hz}
DG	Differential Gain	$R_L = 150\Omega, R_F = 470\Omega, NTSC$		0.03		%
DP	Differential Phase	$R_L = 150\Omega, R_F = 470\Omega, NTSC$		0.03		deg
HD2	2 nd Harmonic Distortion	$f_c = 1MHz, V_O = 2V_{PP}, R_L = 100\Omega$		-90		dBc
		$f_c = 1MHz, V_O = 2V_{PP}, R_L = 500\Omega$		-100		
HD3	3 rd Harmonic Distortion	$f_c = 1MHz, V_O = 2V_{PP}, R_L = 100\Omega$		-94		dBc
		$f_c = 1MHz, V_O = 2V_{PP}, R_L = 500\Omega$		-100		
MTPR	Upstream	$V_O = 0.6 V_{RMS}, 26kHz$ to 132kHz (see test circuit 5)		-78		dBc
	Downstream	$V_O = 0.6 V_{RMS}, 144kHz$ to 1.1MHz (see test circuit 5)		-70		
Input Characteristics						
V_{OS}	Input Offset Voltage	$V_{CM} = 0V$	-1.2 -2	+0.2	+1.2 +2	mV
TC V_{OS}	Input Offset Average Drift	$V_{CM} = 0V$ (Note 7)		-2.5		$\mu V/^\circ C$
I_{OS}	Input Offset Current	$V_{CM} = 0V$	-1 -1.5	-0.04	1 1.5	μA
I_B	Input Bias Current	$V_{CM} = 0V$		4.7	10 15	μA
R_{IN}	Input Resistance	Common Mode		17		M Ω
		Differential Mode		12		k Ω
C_{IN}	Input Capacitance	Common Mode		0.9		pF
		Differential Mode		1.0		pF

±6V Electrical Characteristics (Continued)

Unless otherwise specified, $T_J = 25^\circ\text{C}$, $V^+ = 6\text{V}$, $V^- = -6\text{V}$, $V_{\text{CM}} = 0\text{V}$, $A_V = +2$, $R_F = 500\Omega$, $R_L = 100\Omega$. **Boldface** limits apply at the temperature extremes.

Symbol	Parameter	Conditions	Min (Note 6)	Typ (Note 5)	Max (Note 6)	Units
CMVR	Input Common Mode Voltage Range	CMRR $\geq 60\text{dB}$		-4.75	-4.5	V
			5.5	+5.7		
CMRR	Common-Mode Rejection Ratio	Input Referred, $V_{\text{CM}} = -4.2$ to $+5.2\text{V}$	80 75	100		dB
Transfer Characteristics						
A_{VOL}	Large Signal Voltage Gain	$V_O = 4V_{\text{PP}}$	74 70	83		dB
X_t	Crosstalk	$f = 1\text{MHz}$		-75		dB
Output Characteristics						
V_O	Output Swing	No Load, Positive Swing	4.8 4.6	5.2		V
		No Load, Negative Swing		-5.0	-4.6 -4.4	
		$R_L = 100\Omega$, Positive Swing	4.0 3.8	4.6		
		$R_L = 100\Omega$, Negative Swing		-4.6	-4 -3.8	
R_O	Output Impedance	$f = 1\text{MHz}$		0.08		Ω
I_{SC}	Output Short Circuit Current	Sourcing to Ground $\Delta V_{\text{IN}} = 200\text{mV}$ (Note 3), (Note 9)	100	135		mA
		Sinking to Ground $\Delta V_{\text{IN}} = -200\text{mV}$ (Note 3), (Note 9)	100	130		
I_{OUT}	Output Current	Sourcing, $V_O = +4.3\text{V}$ Sinking, $V_O = -4.3\text{V}$		90		mA
Power Supply						
+PSRR	Positive Power Supply Rejection Ratio	Input Referred, $V_S = +5\text{V}$ to $+6\text{V}$	80 74	95		dB
-PSRR	Negative Power Supply Rejection Ratio	Input Referred, $V_S = -5\text{V}$ to -6V	75 69	90		
I_S	Supply Current (per amplifier)	No Load		4.3	6 6.5	mA

±2.5V Electrical Characteristics

Unless otherwise specified, all limits guaranteed for $T_J = 25^\circ\text{C}$, $V^+ = 2.5\text{V}$, $V^- = -2.5\text{V}$, $V_{\text{CM}} = 0\text{V}$, $A_V = +2$, $R_F = 500\Omega$, $R_L = 100\Omega$. **Boldface** limits apply at the temperature extremes.

Symbol	Parameter	Conditions	Min (Note 6)	Typ (Note 5)	Max (Note 6)	Units
Dynamic Performance						
f_{CL}	-3dB BW	$V_O = 200\text{mV}_{\text{PP}}$		150		MHz
$\text{BW}_{0.1\text{dB}}$	0.1dB Gain Flatness	$V_O = 200\text{mV}_{\text{PP}}$		20		MHz
SR	Slew Rate (Note 8)	$V_O = 2V_{\text{PP}}$		80		V/ μs
T_S	Settling Time	$V_O = 2V_{\text{PP}}$ to $\pm 0.1\%$		45		ns
		$V_O = 2V_{\text{PP}}$ to $\pm 1.0\%$		40		
T_r	Rise Time	$V_O = 0.2\text{V}$ Step, 10% to 90%		2.5		ns
T_f	Fall Time	$V_O = 0.2\text{V}$ Step, 10% to 90%		2.5		ns
Distortion and Noise Response						
e_n	Input Referred Voltage Noise	$f = 100\text{kHz}$		1.7		$\text{nV}/\sqrt{\text{Hz}}$
i_n	Input Referred Current Noise	$f = 100\text{kHz}$		1.5		$\text{pA}/\sqrt{\text{Hz}}$

±2.5V Electrical Characteristics (Continued)

Unless otherwise specified, all limits guaranteed for $T_J = 25^\circ\text{C}$, $V^+ = 2.5\text{V}$, $V^- = -2.5\text{V}$, $V_{CM} = 0\text{V}$, $A_V = +2$, $R_F = 500\Omega$, $R_L = 100\Omega$. **Boldface** limits apply at the temperature extremes.

Symbol	Parameter	Conditions	Min (Note 6)	Typ (Note 5)	Max (Note 6)	Units
HD2	2 nd Harmonic Distortion	$f_c = 1\text{MHz}$, $V_O = 2V_{PP}$, $R_L = 100\Omega$		-88		dBc
		$f_c = 1\text{MHz}$, $V_O = 2V_{PP}$, $R_L = 500\Omega$		-98		
HD3	3 rd Harmonic Distortion	$f_c = 1\text{MHz}$, $V_O = 2V_{PP}$, $R_L = 100\Omega$		-92		dBc
		$f_c = 1\text{MHz}$, $V_O = 2V_{PP}$, $R_L = 500\Omega$		-100		
MTPR	Upstream	$V_O = 0.4V_{RMS}$, 26kHz to 132kHz (see test circuit 5)		-76		dBc
	Downstream	$V_O = 0.4V_{RMS}$, 144kHz to 1.1MHz (see test circuit 5)		-68		
Input Characteristics						
V_{OS}	Input Offset Voltage	$V_{CM} = 0\text{V}$	-1.5 -2.3	+0.3	+1.5 +2.3	mV
TC V_{OS}	Input Offset Average Drift	$V_{CM} = 0\text{V}$ (Note 7)		-2.5		$\mu\text{V}/^\circ\text{C}$
I_{OS}	Input Offset Current	$V_{CM} = 0\text{V}$	-1.5 -2.5	+0.01	1.5 2.5	μA
I_B	Input Bias Current	$V_{CM} = 0\text{V}$		4.6	10 15	μA
R_{IN}	Input Resistance	Common Mode		17		M Ω
		Differential Mode		12		k Ω
C_{IN}	Input Capacitance	Common Mode		0.9		pF
		Differential Mode		1.0		pF
CMVR	Input Common Mode Voltage Range	CMRR $\geq 60\text{dB}$		-1.25 2	-1	V
CMRR	Common Mode Rejection Ratio	Input Referred, $V_{CM} = -0.7$ to $+1.7\text{V}$	80 75	100		dB
Transfer Characteristics						
A_{VOL}	Large Signal Voltage Gain	$V_O = 1V_{PP}$	74	82		dB
X_t	Crosstalk	$f = 1\text{MHz}$		-75		dB
Output Characteristics						
V_O	Output Swing	No Load, Positive Swing	1.4 1.2	1.7		V
		No Load, Negative Swing		-1.5	-1.2 -1	
		$R_L = 100\Omega$, Positive Swing	1.2 1	1.5		
		$R_L = 100\Omega$, Negative Swing		-1.4	-1.1 -0.9	
R_O	Output Impedance	$f = 1\text{MHz}$		0.1		Ω
I_{SC}	Output Short Circuit Current	Sourcing to Ground $\Delta V_{IN} = 200\text{mV}$ (Note 3), (Note 9)	100	137		mA
		Sinking to Ground $\Delta V_{IN} = -200\text{mV}$ (Note 3), (Note 9)	100	134		
I_{OUT}	Output Current	Sourcing, $V_O = +0.8\text{V}$ Sinking, $V_O = -0.8\text{V}$		90		mA
Power Supply						
+PSRR	Positive Power Supply Rejection Ratio	Input Referred, $V_S = +2.5\text{V}$ to $+3\text{V}$	78 72	93		dB
-PSRR	Negative Power Supply Rejection Ratio	Input Referred, $V_S = -2.5\text{V}$ to -3V	75 70	88		dB

±2.5V Electrical Characteristics (Continued)

Unless otherwise specified, all limits guaranteed for $T_J = 25^\circ\text{C}$, $V^+ = 2.5\text{V}$, $V^- = -2.5\text{V}$, $V_{\text{CM}} = 0\text{V}$, $A_V = +2$, $R_F = 500\Omega$, $R_L = 100\Omega$. **Boldface** limits apply at the temperature extremes.

Symbol	Parameter	Conditions	Min (Note 6)	Typ (Note 5)	Max (Note 6)	Units
I_S	Supply Current (per amplifier)	No Load		4.1	5.8 6.4	mA

Note 1: Absolute Maximum Ratings indicate limits beyond which damage to the device may occur. Operating Ratings indicate conditions for which the device is intended to be functional, but specific performance is not guaranteed. For guaranteed specifications and the test conditions, see the Electrical Characteristics.

Note 2: Human body model, 1.5k Ω in series with 100pF. Machine model, 0 Ω in series with 200pF.

Note 3: Applies to both single-supply and split-supply operation. Continuous short circuit operation at elevated ambient temperature can result in exceeding the maximum allowed junction temperature of 150°C.

Note 4: The maximum power dissipation is a function of $T_{J(\text{MAX})}$, θ_{JA} and T_A . The maximum allowable power dissipation at any ambient temperature is $P_D = (T_{J(\text{MAX})} - T_A)/\theta_{JA}$. All numbers apply for packages soldered directly onto a PC board.

Note 5: Typical values represent the most likely parametric norm.

Note 6: All limits are guaranteed by testing or statistical analysis.

Note 7: Offset voltage average drift is determined by dividing the change in V_{OS} at temperature extremes into the total temperature change.

Note 8: Slew rate is the slowest of the rising and falling slew rates.

Note 9: Short circuit test is a momentary test. Output short circuit duration is infinite for $V_S \leq \pm 2.5\text{V}$, at room temperature and below. For $V_S > \pm 2.5\text{V}$, allowable short circuit duration is 1.5ms.

Typical Performance Characteristics

Current and Voltage Noise vs. Frequency

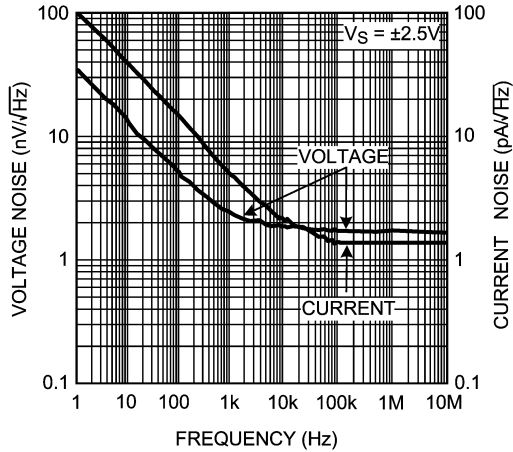

20029224

Current and Voltage Noise vs. Frequency

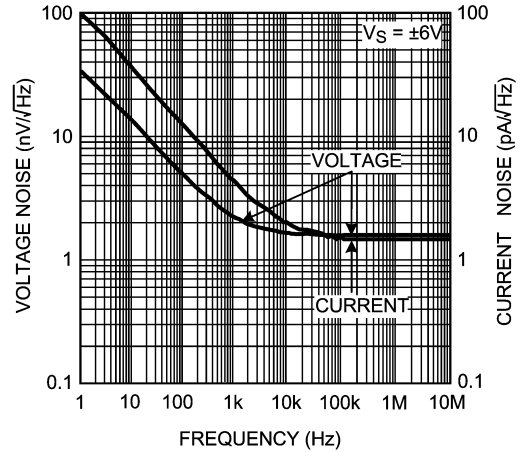

20029225

Frequency Response vs. Input Signal Level

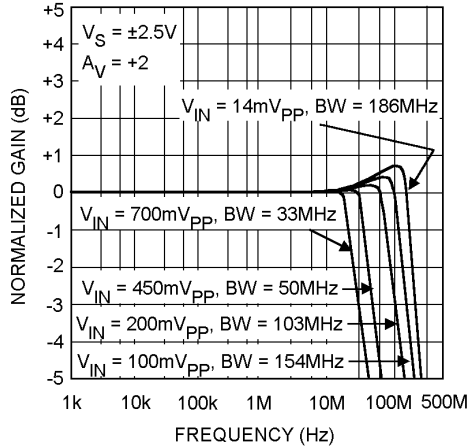

20029202

Frequency Response vs. Input Signal Level

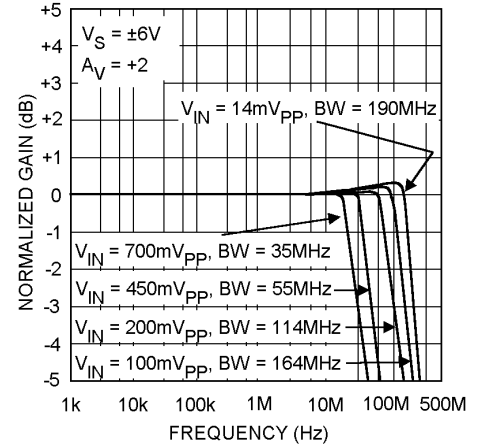

20029203

Inverting Amplifier Frequency Response

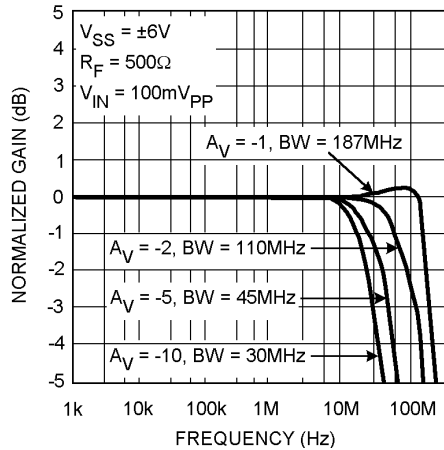

20029246

Non-Inverting Amplifier Frequency Response

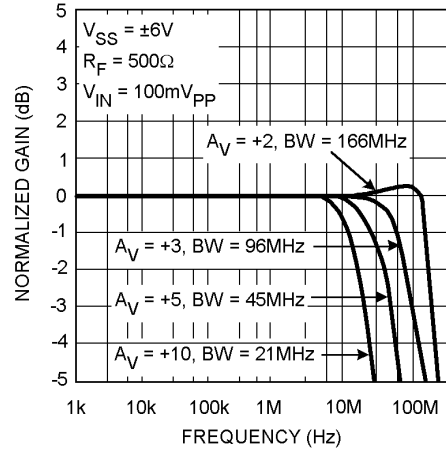

20029247

Typical Performance Characteristics (Continued)

Open Loop Gain and Phase Response

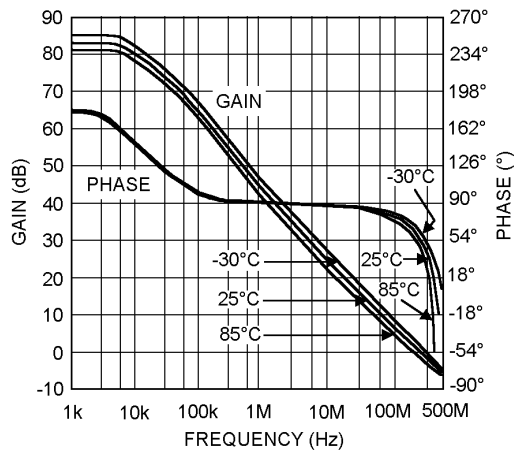

20029205

Crosstalk vs. Frequency

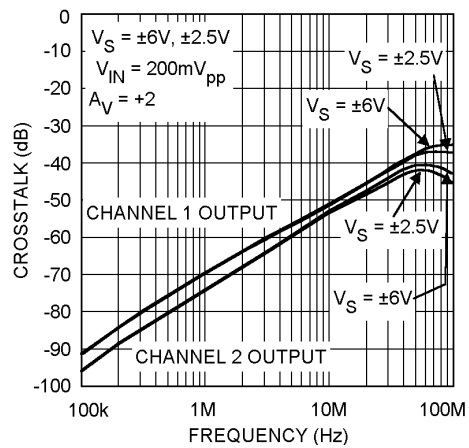

20029201

PSRR vs. Frequency

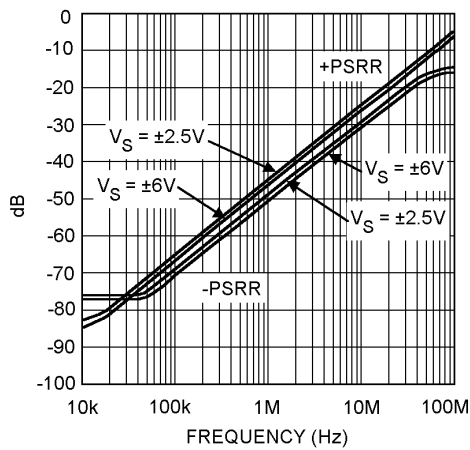

20029204

CMRR vs. Frequency

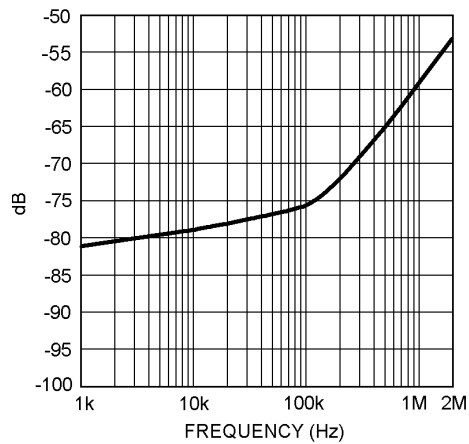

20029206

Positive Output Swing vs. Source Current

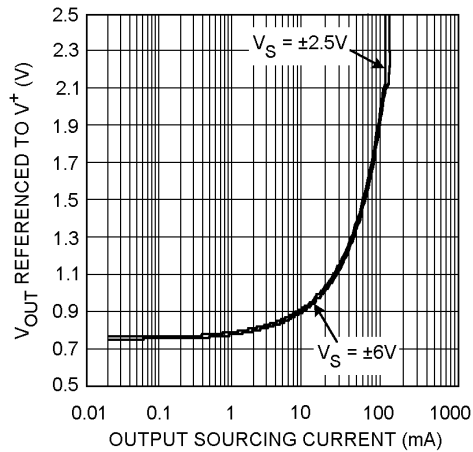

20029248

Negative Output Swing vs. Sink Current

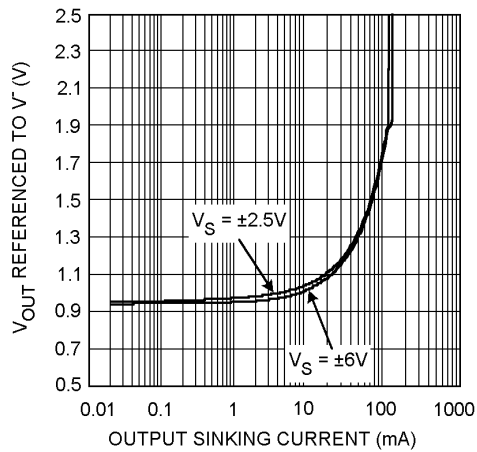

20029249

Typical Performance Characteristics (Continued)

Non-Inverting Small Signal Pulse Response
 $V_S = \pm 2.5V, R_L = 100\Omega, A_V = +2, R_F = 500\Omega$

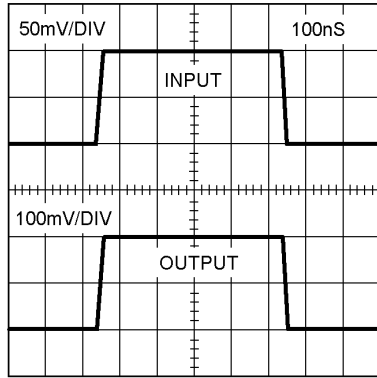

20029207

Non-Inverting Small Signal Pulse Response
 $V_S = \pm 6V, R_L = 100\Omega, A_V = +2, R_F = 500\Omega$

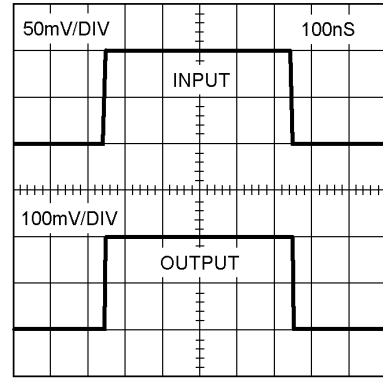

20029209

Non-Inverting Large Signal Pulse Response
 $V_S = \pm 2.5V, R_L = 100\Omega, A_V = +2, R_F = 500\Omega$

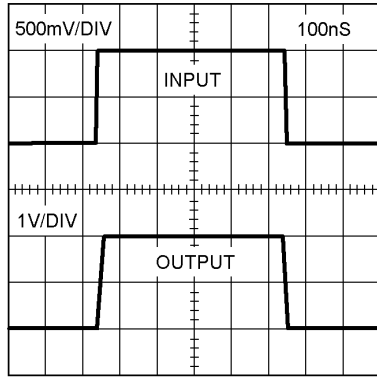

20029208

Non-Inverting Large Signal Pulse Response
 $V_S = \pm 6V, R_L = 100\Omega, A_V = +2, R_F = 500\Omega$

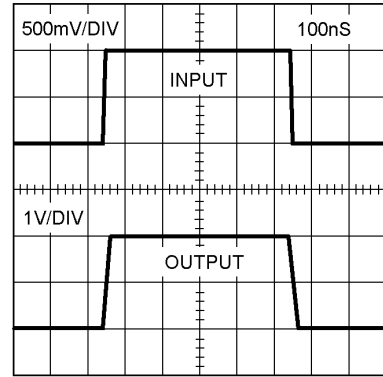

20029210

Harmonic Distortion vs. Input Signal Level

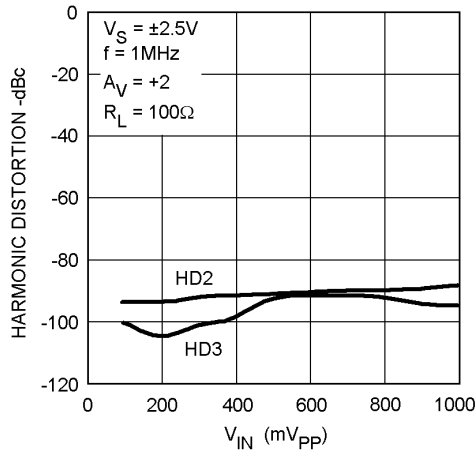

20029212

Harmonic Distortion vs. Input Signal Level

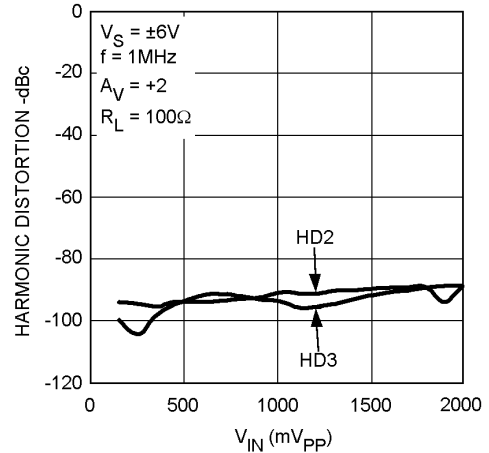

20029213

Typical Performance Characteristics (Continued)

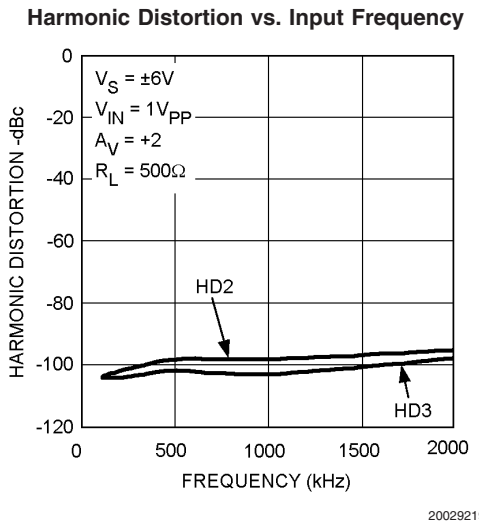
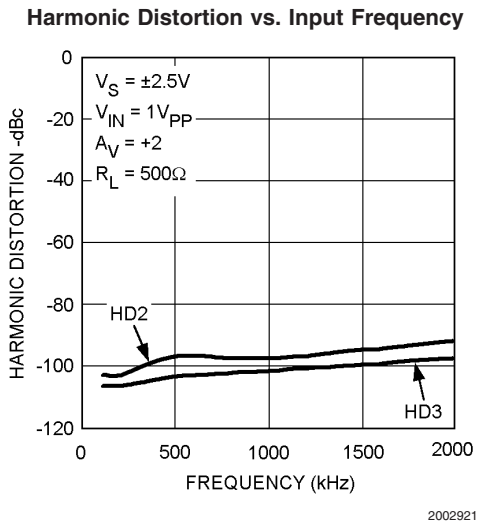
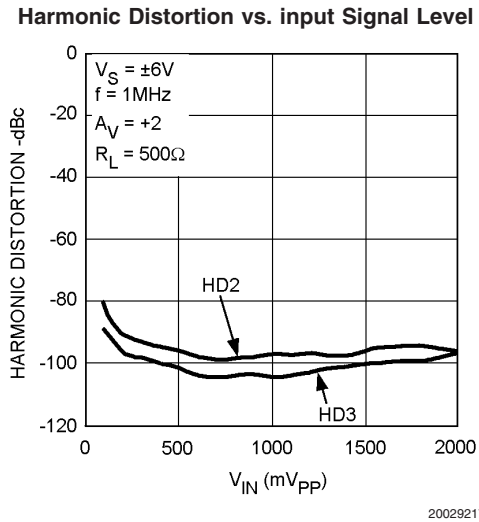
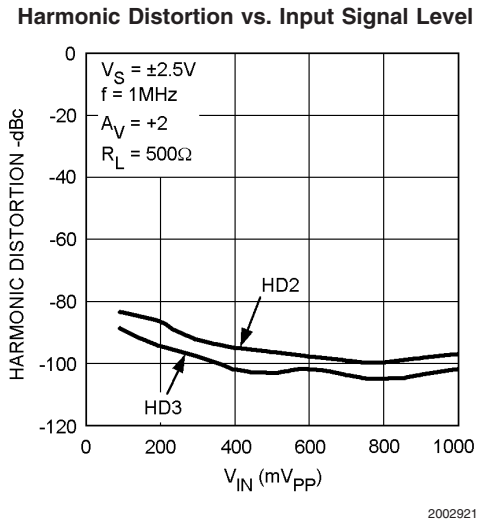
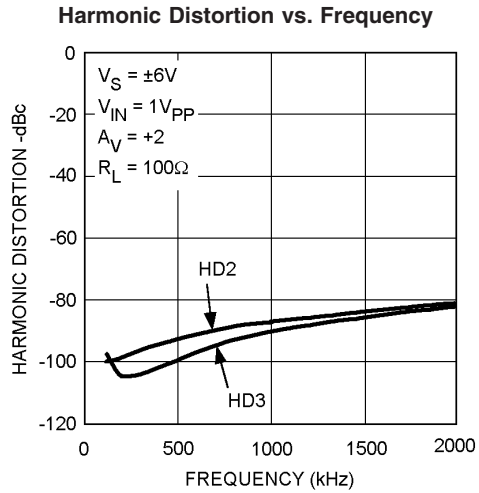
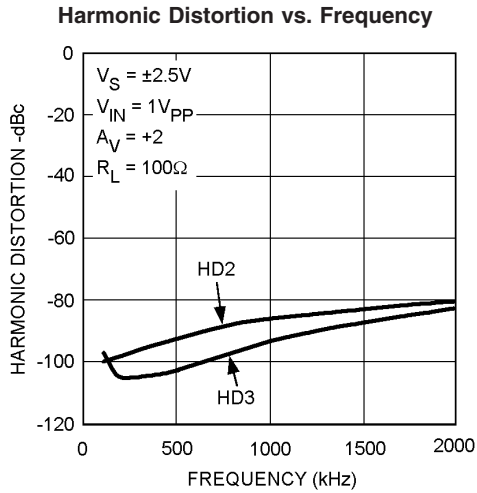

Typical Performance Characteristics (Continued)

Full Rate ADSL (DMT) Upstream MTPR @ $V_S = \pm 2.5V$

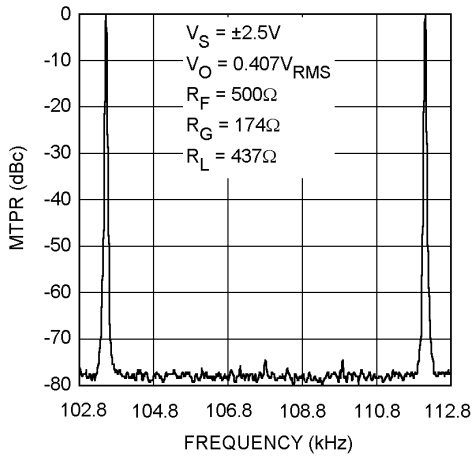

20029256

Full Rate ADSL (DMT) Downstream MTPR @ $V_S = \pm 2.5V$

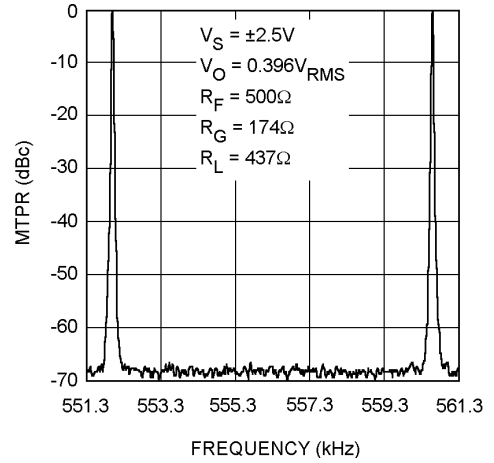

20029258

Full Rate ADSL (DMT) Upstream MTPR @ $V_S = \pm 6V$

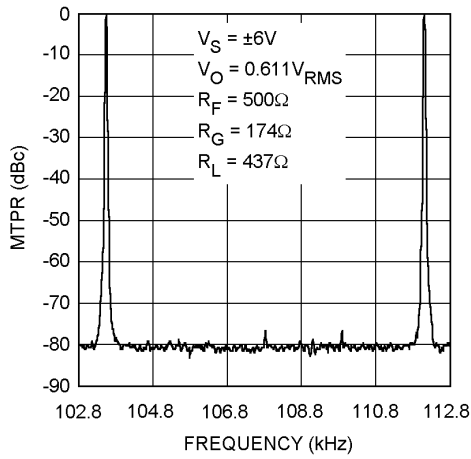

20029257

Full Rate ADSL (DMT) Downstream MTPR @ $V_S = \pm 6V$

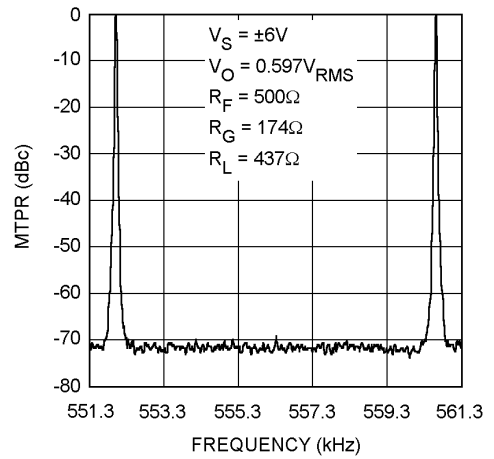

20029259

Connection Diagram

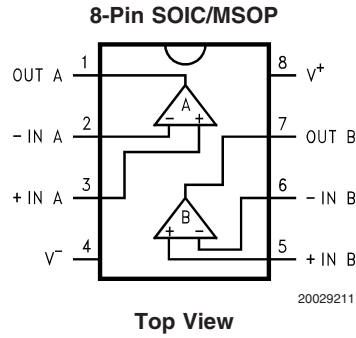

Ordering Information

Package	Part Number	Package Marking	Transport Media	NSC Drawing
8-Pin SOIC	LMH6622MA	LMH6622MA	95 Units per Rail	M08A
	LMH6622MAX		2.5k Units Tape and Reel	
8-Pin MSOP	LMH6622MM	A80A	1k Units Tape and Reel	MUA08A
	LMH6622MMX		3.5k Units Tape and Reel	

Test Circuits

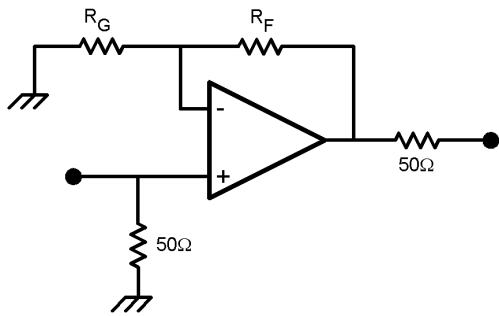

1) Non-Inverting Amplifier

20029250

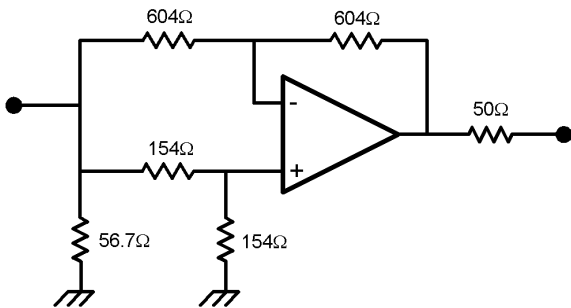

2) CMRR

20029251

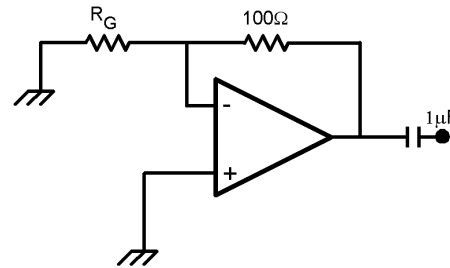

3) Voltage Noise

$R_G = 1\Omega$ for $f \leq 100\text{kHz}$, $R_G = 20\Omega$ for $f > 100\text{kHz}$

20029253

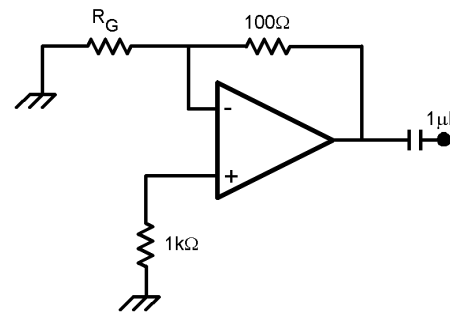

4) Current Noise

$R_G = 1\Omega$ for $f \leq 100\text{kHz}$, $R_G = 20\Omega$ for $f > 100\text{kHz}$

20029252

Test Circuits (Continued)

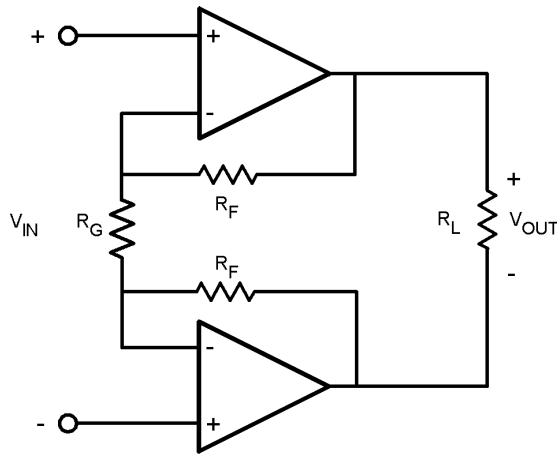

20029255
5) Multitone Power Ratio, $R_F = 500\Omega$, $R_G = 174\Omega$, $R_L = 437\Omega$

DSL Receive Channel Applications

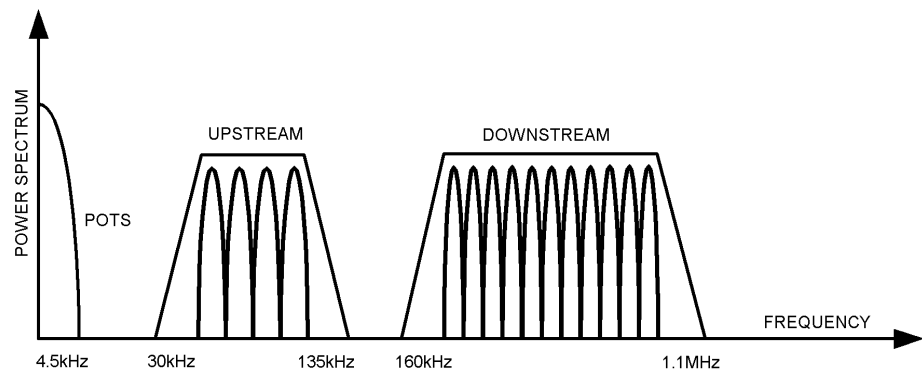

20029223

FIGURE 1. ADSL Signal Description

The LMH6622 is a dual, wideband operational amplifier designed for use as a DSL line receiver. In the receive band of a Customer Premises Equipment (CPE) ADSL modem it is possible that as many as 255 Discrete Multi-Tone (DMT) QAM signals will be present, each with its own carrier frequency, modulation, and signal level. The ADSL standard requires a line referred noise power density of -140dBm/Hz within the CPE receive band of 100kHz to 1.1MHz . The CPE driver output signal will leak into the receive path because of full duplex operation and the imperfections of the hybrid coupler circuit. The DSL analog front end must incorporate a

receiver pre-amp which is both low noise and highly linear for ADSL-standard operation. The LMH6622 is designed for the twin performance parameters of low noise and high linearity.

Applications ranging from $+5\text{V}$ to $+12\text{V}$ or $\pm 2.5\text{V}$ to $\pm 6\text{V}$ are fully supported by the LMH6622. In Figure 2, the LMH6622 is used as an inverting summing amplifier to provide both received pre-amp channel gain and driver output signal cancellation, i.e., the function of a hybrid coupler.

DSL Receive Channel Applications (Continued)

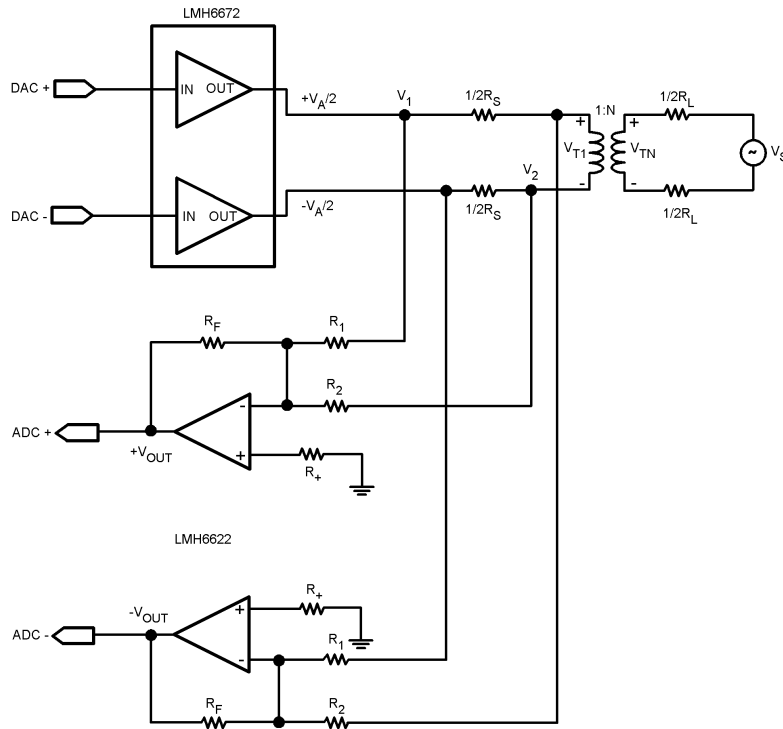

20029227

FIGURE 2. ADSL Receive Applications Circuit

DSL Receive Channel Applications

(Continued)

The two R_S resistors are used to provide impedance matching through the 1:N transformer.

$$R_S = \frac{R_L}{N^2}$$

Where R_L is the impedance of the twisted pair line.

N is the turns ratio of the transformer.

The resistors R_2 and R_F are used to set the receive gain of the pre-amp. The receive gain is selected to meet the ADC full-scale requirement of a DSL chipset.

Resistor R_1 and R_2 along with R_F are used to achieve cancellation of the output driver signal at the output of the receiver.

Since the LMH6622 is configured as an inverting summing amplifier, V_{OUT} is found to be,

$$V_{OUT} = -R_F \left[\frac{V_1}{R_1} + \frac{V_2}{R_2} \right]$$

The expression for V_1 and V_2 can be found by using superposition principle.

When $V_S = 0$,

$$V_1 = \frac{1}{2}V_A \quad \text{and} \quad V_2 = -\frac{1}{4}V_A$$

When $V_A = 0$,

$$V_1 = 0 \quad \text{and} \quad V_2 = -\frac{1}{2}V_{T1}$$

Therefore,

$$V_1 = \frac{1}{2}V_A \quad \text{and} \quad V_2 = -\frac{1}{4}V_A - \frac{1}{2}V_{T1}$$

And then,

$$V_{OUT} = -R_F \left[\frac{V_A}{2R_1} - \frac{V_A}{4R_2} - \frac{V_{T1}}{2R_2} \right]$$

Setting $R_1 = 2R_2$ to cancel unwanted driver signal in the receive path, then we have

$$V_{OUT} = \frac{R_F}{2R_2} V_{T1}$$

We can also find that,

$$V_{TN} = \frac{1}{2}V_S \quad \text{and} \quad V_{T1} = \frac{1}{N}V_{TN} = \frac{1}{2N}V_S$$

And then

$$V_{OUT} = \frac{R_F}{4NR_2} V_S$$

In conclusion, the peak-to-peak voltage to the ADC would be,

$$2 V_{OUT} = \frac{R_F}{2NR_2} V_S$$

RECEIVE CHANNEL NOISE CALCULATION

The circuit of *Figure 2* also has the characteristic that it cancels noise power from the drive channel.

The noise gain of the receive pre-amp is found to be:

$$A_N = 1 + \frac{R_F}{R_1 // R_2}$$

Noise power at each of the output of LMH6622:

$$e^2_o = A_N^2 [V_n^2 + i_{non-inv}^2 R_+^2 + 4kT R_+] + i_{inv}^2 R_F^2 + 4kT R_F A_n$$

where

V_n	Input referred voltage noise
i_n	Input referred current noise
$i_{non-inv}$	Input referred non-inverting current noise
i_{inv}	Input referred inverting current noise
k	Boltzmann's constant, $K = 1.38 \times 10^{-23}$
T	Resistor temperature in k
R_+	Source resistance at the non-inverting input to balance offset voltage, typically very small for this inverting summing applications

For a voltage feedback amplifier,

$$i_{inv} = i_{non-inv} = i_n$$

Therefore, total output noise from the differential pre-amp is:

$$e^2_{TotalOutput} = 2 e^2_o$$

The factor '2' appears here because of differential output.

DIFFERENTIAL ANALOG-TO-DIGITAL DRIVER

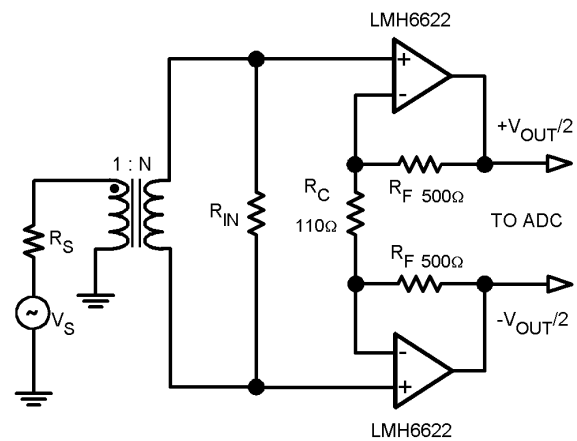

20029239

FIGURE 3. Circuit for Differential A/D Driver

DSL Receive Channel Applications

(Continued)

The LMH6622 is a low noise, low distortion high speed operational amplifier. The LMH6622 comes in either SOIC-8 or MSOP-8 packages. Because two channels are available in each package the LMH6622 can be used as a high dynamic range differential amplifier for the purpose of driving a high speed analog-to-digital converter. Driving a 1k Ω load, the differential amplifier of *Figure 3* provides 20dB gain, a flat frequency response up to 6MHz, and harmonic distortion that is lower than 80dBc. This circuit makes use of a transformer to convert a single-ended signal to a differential signal. The input resistor R_{IN} is chosen by the following equation,

$$R_{IN} = \frac{1}{N^2} R_S$$

The gain of this differential amplifier can be adjusted by R_C and R_F ,

$$A_V = 2 \frac{R_F}{R_C}$$

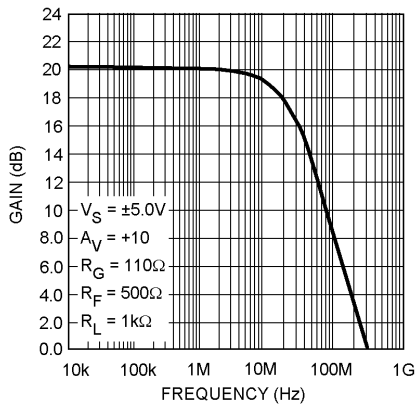

20029221

FIGURE 4. Frequency Response

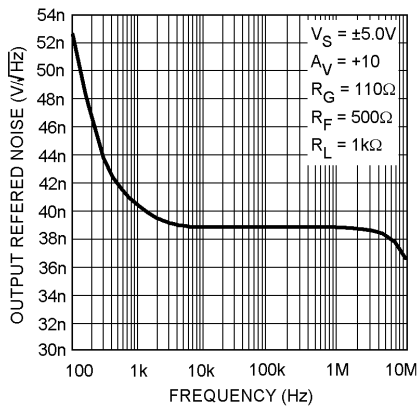

20029222

FIGURE 5. Total Output Referred Noise Density

CIRCUIT LAYOUT CONSIDERATIONS

National Semiconductor suggests the copper patterns on the evaluation boards listed below as a guide for high frequency layout. These boards are also useful as an aid in device testing and characterization. As is the case with all high-speed amplifiers, accepted-practice R_F design technique on the PCB layout is mandatory. Generally, a good high frequency layout exhibits a separation of power supply and ground traces from the inverting input and output pins. Parasitic capacitances between these nodes and ground will cause frequency response peaking and possible circuit oscillations (see Application Note OA-15 for more information). High quality chip capacitors with values in the range of 100pF to 0.1 μ F should be used for power supply bypassing. One terminal of each chip capacitor is connected to the ground plane and the other terminal is connected to a point that is as close as possible to each supply pin as allowed by the manufacturer's design rules. In addition, a tantalum capacitor with a value between 4.7 μ F and 10 μ F should be connected in parallel with the chip capacitor. Signal lines connecting the feedback and gain resistors should be as short as possible to minimize inductance and microstrip line effect. Input and output termination resistors should be placed as close as possible to the input/output pins. Traces greater than 1 inch in length should be impedance matched to the corresponding load termination.

Symmetry between the positive and negative paths in the layout of differential circuitry should be maintained so as to minimize the imbalance of amplitude and phase of the differential signal.

Device	Package	Evaluation Board P/N
LMH6622MA	SOIC-8	CLC730036
LMH6622MM	MSOP-8	CLC730123

These free evaluation boards are shipped when a device sample request is placed with National Semiconductor.

Component value selection is another important parameter in working with high speed/high performance amplifiers. Choosing external resistors that are large in value compared to the value of other critical components will affect the closed loop behavior of the stage because of the interaction of these resistors with parasitic capacitances. These parasitic capacitors could either be inherent to the device or be a by-product of the board layout and component placement. Moreover, a large resistor will also add more thermal noise to the signal path. Either way, keeping the resistor values low will diminish this interaction. On the other hand, choosing very low value resistors could load down nodes and will contribute to higher overall power dissipation and worse distortion.

DRIVING CAPACITIVE LOAD

Capacitive Loads decrease the phase margin of all op amps. The output impedance of a feedback amplifier becomes inductive at high frequencies, creating a resonant circuit when the load is capacitive. This can lead to overshoot, ringing and oscillation. To eliminate oscillation or reduce ringing, an isolation resistor can be placed between the load and the output. In general, the bigger the isolation resistor, the more damped the pulse response becomes. For initial evaluation, a 50 Ω isolation resistor is recommended.

Physical Dimensions inches (millimeters) unless otherwise noted

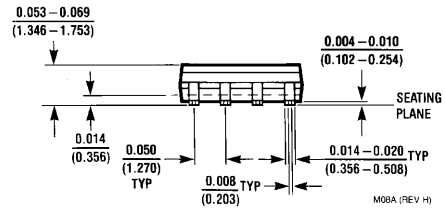
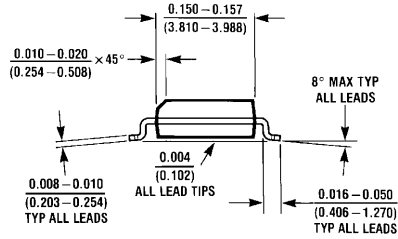
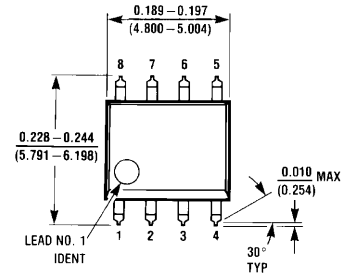

8-Pin SOIC
NS Package Number M08A

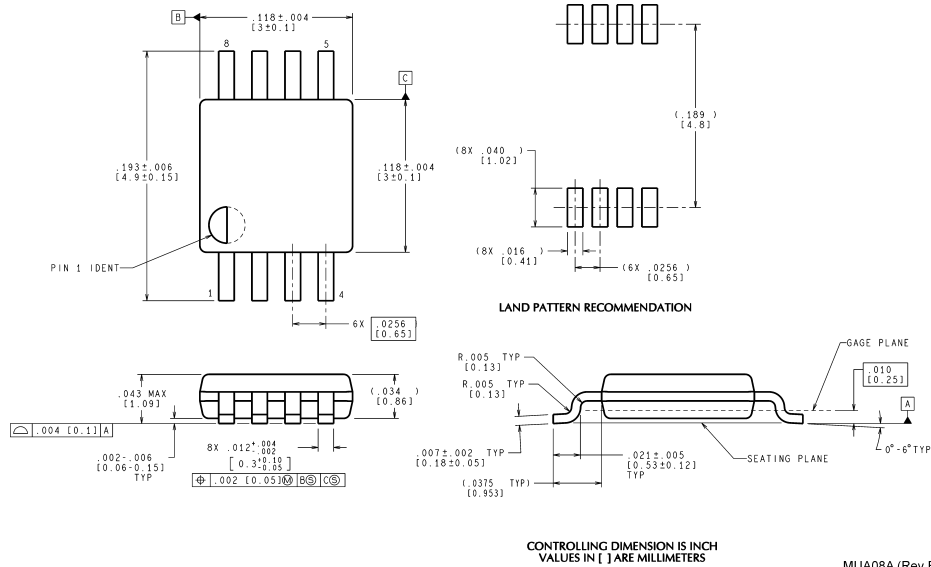

8-Pin MSOP
NS Package Number MUA08A

CONTROLLING DIMENSION IS INCH
VALUES IN [] ARE MILLIMETERS

MUA08A (Rev E)

Notes

National does not assume any responsibility for use of any circuitry described, no circuit patent licenses are implied and National reserves the right at any time without notice to change said circuitry and specifications.

For the most current product information visit us at www.national.com.

LIFE SUPPORT POLICY

NATIONAL'S PRODUCTS ARE NOT AUTHORIZED FOR USE AS CRITICAL COMPONENTS IN LIFE SUPPORT DEVICES OR SYSTEMS WITHOUT THE EXPRESS WRITTEN APPROVAL OF THE PRESIDENT AND GENERAL COUNSEL OF NATIONAL SEMICONDUCTOR CORPORATION. As used herein:

- | | |
|--|---|
| <p>1. Life support devices or systems are devices or systems which, (a) are intended for surgical implant into the body, or (b) support or sustain life, and whose failure to perform when properly used in accordance with instructions for use provided in the labeling, can be reasonably expected to result in a significant injury to the user.</p> | <p>2. A critical component is any component of a life support device or system whose failure to perform can be reasonably expected to cause the failure of the life support device or system, or to affect its safety or effectiveness.</p> |
|--|---|

BANNED SUBSTANCE COMPLIANCE

National Semiconductor manufactures products and uses packing materials that meet the provisions of the Customer Products Stewardship Specification (CSP-9-111C2) and the Banned Substances and Materials of Interest Specification (CSP-9-111S2) and contain no "Banned Substances" as defined in CSP-9-111S2.

Leadfree products are RoHS compliant.



National Semiconductor
Americas Customer
Support Center
Email: new.feedback@nsc.com
Tel: 1-800-272-9959

National Semiconductor
Europe Customer Support Center
Fax: +49 (0) 180-530 85 86
Email: europe.support@nsc.com
Deutsch Tel: +49 (0) 69 9508 6208
English Tel: +44 (0) 870 24 0 2171
Français Tel: +33 (0) 1 41 91 8790

National Semiconductor
Asia Pacific Customer
Support Center
Email: ap.support@nsc.com

National Semiconductor
Japan Customer Support Center
Fax: 81-3-5639-7507
Email: jpn.feedback@nsc.com
Tel: 81-3-5639-7560

www.national.com