

# DATA SHEET

## **TJA1053** Fault-tolerant CAN transceiver

Product specification  
Supersedes data of 1997 Oct 15  
File under Integrated Circuits, IC18

2000 Dec 18

## Fault-tolerant CAN transceiver

## TJA1053

### FEATURES

#### Optimized for in-car low-speed communication

- Baud rate up to 125 kbaud
- Up to 32 nodes can be connected
- Supports unshielded bus wires
- Low RFI due to built-in slope control function
- Fully integrated receiver filters
- Permanent dominant monitoring of TXD.

#### Bus failure management

- Supports one-wire transmission modes with ground offset voltages up to 1.5 V
- Automatic switching to single-wire mode in the event of bus failure
- Automatic reset to differential mode if bus failure is removed.

#### Protection

- Short-circuit proof to battery and ground in 12 V powered systems
- Thermally protected
- Bus lines protected against transients in an automotive environment

- An unpowered node does not disturb the bus lines.

#### Support for low-power modes

- Low current sleep/standby mode with wake-up via the bus lines
- Power-on reset flag on the output.

### GENERAL DESCRIPTION

The TJA1053 is the interface between the CAN protocol controller and the physical bus. It is primarily intended for low-speed applications, up to 125 kbaud, in passenger cars. The device provides differential transmit capability but will switch in error conditions to a single-wire transmitter and/or receiver. The TJA1053 is derived from the PCA82C252 giving the following advantages:

- Better equipped for networks with more than 15 nodes
- Integrated timer at the TXD input prevents a permanent dominant state
- Reduced supply current in  $V_{CC}$  standby mode
- CANH output driver is disabled in the event of a 'CANH short-circuited to battery' failure mode.

### QUICK REFERENCE DATA

SYMBOL	PARAMETER	CONDITIONS	MIN.	TYP.	MIN.	UNIT
$V_{CC}$	supply voltage		4.75	–	5.25	V
$V_{BAT}$	battery voltage	no time limit	–0.3	–	+27	V
		operating	6.0	–	27	V
		load dump	–	–	40	V
$I_{BAT(sleep)}$	sleep mode current	$V_{CC} = 0\text{ V}; V_{BAT} = 12\text{ V}$	–	65	–	$\mu\text{A}$
$V_{CANH}, V_{CANL}$	CANH, CANL input voltage	$V_{CC} = 0\text{ to }5.5\text{ V}; V_{BAT} \geq 0\text{ V};$ no time limit	–10	–	+27	V
		$V_{CC} = 0\text{ to }5.5\text{ V}; V_{BAT} \geq 0\text{ V};$ $t < 0.1\text{ ms};$ load dump	–40	–	+40	V
$V_{DROPH}$	CANH transmitter drop voltage	$I_{CANH} = 40\text{ mA}$	–	–	1.4	V
$V_{DROPL}$	CANL transmitter drop voltage	$I_{CANL} = 40\text{ mA}$	–	–	1.4	V
$t_{PD}$	propagation delay	TXD to RXD	–	1	–	$\mu\text{s}$
$t_f$	bus output fall time	90% to 10%	–	0.5	–	$\mu\text{s}$
$t_r$	bus output rise time	10% to 90%	–	0.5	–	$\mu\text{s}$
$T_{amb}$	operating ambient temperature		–40	–	+125	$^{\circ}\text{C}$

# Fault-tolerant CAN transceiver

# TJA1053

## ORDERING INFORMATION

TYPE NUMBER	PACKAGE		
	NAME	DESCRIPTION	VERSION
TJA1053T	SO14	plastic small outline package; 14 leads; body width 3.9 mm	SOT108-1

## BLOCK DIAGRAM

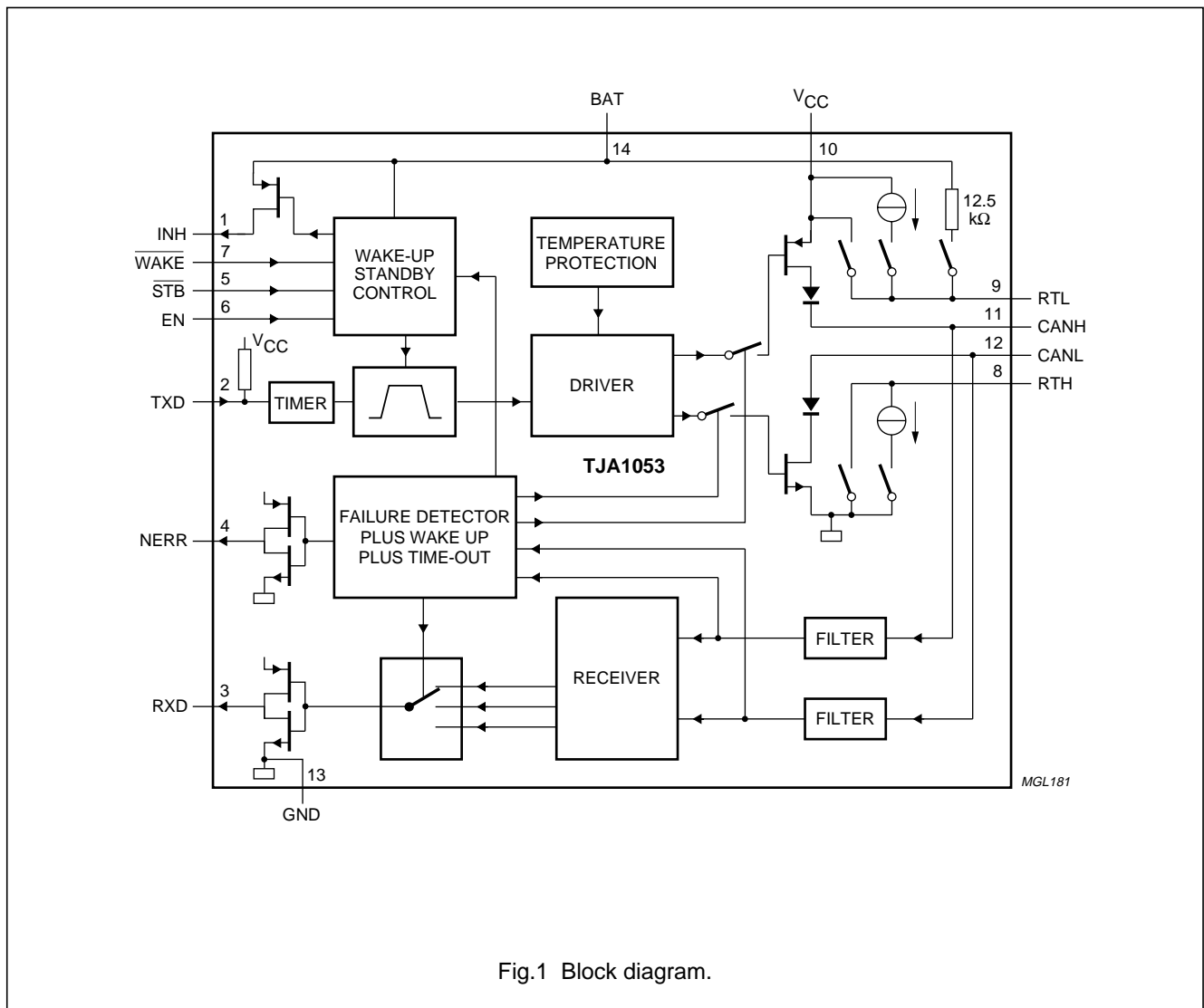

Fig.1 Block diagram.

# Fault-tolerant CAN transceiver

# TJA1053

## PINNING

SYMBOL	PIN	DESCRIPTION
INH	1	inhibit output for switching external 5 V regulator
TXD	2	transmit data input, when LOW bus data will be dominant, when HIGH bus data will be recessive
RXD	3	receive data output, when LOW bus data will be dominant
NERR	4	error output pin, when LOW a bus error exists
STB	5	not standby digital control input signal (active LOW)
EN	6	enable digital control input signal
WAKE	7	not wake input signal, when pulled down INH becomes active for wake-up (active LOW)
RTH	8	termination resistor, CANH line will be high-impedance with certain bus errors
RTL	9	termination resistor, CANL line will be high-impedance with certain bus errors
V <sub>CC</sub>	10	supply voltage (+5 V)
CANH	11	high voltage bus line, will be HIGH in dominant state
CANL	12	low voltage bus line, will be LOW in dominant state
GND	13	ground
BAT	14	battery voltage

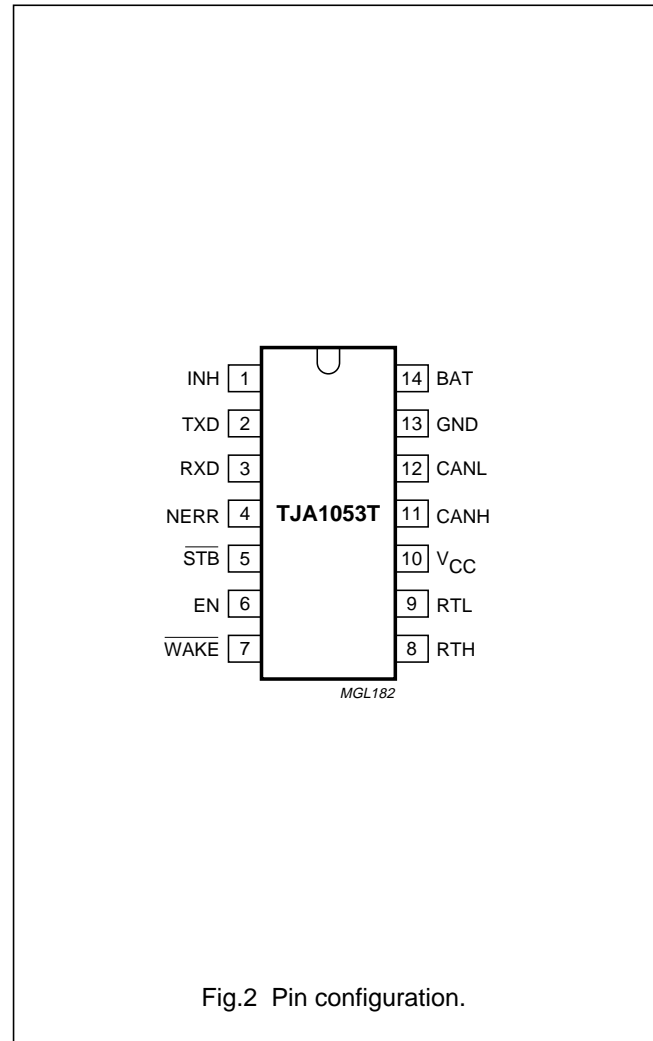

Fig.2 Pin configuration.

## Fault-tolerant CAN transceiver

TJA1053

### FUNCTIONAL DESCRIPTION

The TJA1053 is the interface between the CAN protocol controller and the physical bus. It is primarily intended for low speed applications, up to 125 kbaud, in passenger cars. The device provides differential transmit capability to the bus and differential receive capability to the CAN controller.

To reduce RF interference the rise and fall slope are limited. This allows the use of an unshielded twisted pair or a parallel pair of wires for the bus. Moreover, it supports transmission capability on either bus wire if one of the bus wires is corrupted. The failure detection logic automatically selects a suitable transmission mode.

In normal operation (no wiring failures) the differential receiver is output to RXD. The differential receiver inputs are connected to CANH and CANL through integrated filters. The filtered input signals are also used for the single wire receivers. The CANH and CANL receivers have threshold voltages that ensure a maximum noise margin in single-wire modes.

A timer has been integrated at the TXD input. This timer prevents the TJA1053 driving the bus lines to permanent dominant state.

#### Failure detector

The failure detector is active in the normal operation mode and detects the following single bus failures and switches to an appropriate mode:

1. CANH wire interrupted
2. CANL wire interrupted
3. CANH short-circuited to battery
4. CANL short-circuited to ground
5. CANH short-circuited to ground
6. CANL short-circuited to battery
7. CANL mutually shorted to CANH.

The differential receiver threshold is set at  $-2.9$  V. This ensures correct reception in the normal operating modes and, in the event of failures 1, 2 and 5 with a noise margin as high as possible. These failures, or recovery from them, do not destroy ongoing transmissions.

Failures 3 and 6 are detected by comparators connected to CANH and CANL, respectively. If the comparator threshold is exceeded for a certain period of time, the reception is switched to the single-wire mode.

This time is needed to avoid false triggering by external RF fields. Recovery from these failures is detected automatically after a certain time-out (filtering) and no transmission is lost. The CANH driver and the RTH pin are switched off in the event of failure 3.

Failures 4 and 7 initially result in a permanent dominant level at RXD. After a time-out, the CANL driver and the RTL pin are switched off. Only a weak pull-up at RTL remains. Reception continues by switching to the single-wire mode via CANH. When failures 4 or 7 are removed, the recessive bus levels are restored. If the differential voltage remains below the recessive threshold level for a certain period of time, reception and transmission switch back to the differential mode.

If any of the seven wiring failures occur, the output NERR will be made LOW. On error recovery, NERR will be made HIGH again.

During all single-wire transmissions, the EMC performance (both immunity and emission) is worse than in the differential mode. Integrated receiver filters suppress any HF noise induced into the bus wires. The cut-off frequency of these filters is a compromise between propagation delay and HF suppression. In the single-wire mode, low frequency noise cannot be distinguished from the required signal.

#### Low power modes

The transceiver provides 3 low power modes which can be entered and exited via pins  $\overline{\text{STB}}$  and EN (see Table 1).

The sleep mode is the mode with the lowest power consumption. The INH pin is switched to high-impedance for deactivation of external voltage regulators. CANL is biased to the battery voltage via the RTL output. If the supply voltage is provided the RXD and NERR will signal the wake-up interrupt

The  $V_{\text{BAT}}$  standby mode will react the same as the sleep mode with an active INH output.

The  $V_{\text{CC}}$  standby mode is the  $V_{\text{BAT}}$  standby with RTL switched to the  $V_{\text{CC}}$  voltage. In this mode the NERR output signals the  $V_{\text{BAT}}$  power-on flag and the RXD output will show the wake-up interrupt.

# Fault-tolerant CAN transceiver

# TJA1053

Wake-up requests are recognized by the transceiver when a dominant signal is detected on either bus line or if the  $\overline{\text{WAKE}}$  pin is connected to ground. On a wake-up request the transceiver will set the INH output which can be used to activate the external  $V_{CC}$  voltage regulator. If  $V_{CC}$  is provided the wake-up request can be read on the NERR or RXD outputs, on which the external microcontroller can wake up the transceiver (switch to normal operating mode) via  $\overline{\text{STB}}$  and EN.

To prevent false wake-up due to transients or RF fields, wake-up voltage threshold levels have to be maintained for a certain period of time. In the low power modes the failure detection circuit remains partly active to prevent increased power consumption should errors 3, 4 and 7 occur.

### Power on

After power-on  $V_{BAT}$  is switched on, the INH pin will become HIGH and an internal power-on flag will be set. This flag can be read via the NERR pin ( $\overline{\text{STB}} = 1, \text{EN} = 0$ ) and will be reset by entering the normal operation mode.

The EN and  $\overline{\text{STB}}$  pins will internally be set to LOW level, if the  $V_{CC}$  voltage is below a certain threshold level, to provide fail safe functionality.

### Protections

A current limiting circuit protects the transmitter output stages against short-circuit to positive and negative battery voltage.

If the junction temperature exceeds a maximum value, the transmitter output stages are disabled. Because the transmitter is responsible for the major part of the power dissipation, this will result in a reduced power dissipation and hence a lower chip temperature. All other parts of the IC will remain operating.

The CANH and CANL inputs are protected against electrical transients which may occur in an automotive environment.

**Table 1** Truth table of CAN transceiver

STB	EN	MODE	INH	NERR	RXD	RTL
0	0	$V_{BAT}$ standby <sup>(1)</sup>	HIGH	active LOW wake-up interrupt signal if $V_{CC}$ is present		switched to $V_{BAT}$
0	0	sleep <sup>(2)</sup>	floating			switched to $V_{BAT}$
0	1	go to sleep command	floating			switched to $V_{BAT}$
1	0	$V_{CC}$ standby <sup>(3)</sup>	HIGH	active LOW $V_{BAT}$ power-on flag	active LOW wake-up interrupt	switched to $V_{CC}$
1	1	normal operation mode	HIGH	active LOW error flag	HIGH = receive; LOW = dominant received data	switched to $V_{CC}$

### Notes

1. Wake-up interrupts are released when entering normal operating mode.
2. If go to sleep command was used before (EN may turn LOW as  $V_{CC}$  drops, without affecting internal functions because of fail safe functionality).
3.  $V_{BAT}$  power-on flag will be reset when entering normal operation mode.

## Fault-tolerant CAN transceiver

TJA1053

**LIMITING VALUES**

In accordance with the Absolute Maximum Rating System (IEC 60134).

SYMBOL	PARAMETER	CONDITIONS	MIN.	MAX.	UNIT
V <sub>CC</sub>	supply voltage		-0.3	+6.0	V
V <sub>DD</sub>	DC input voltage at pins 2 to 6		-0.3	V <sub>CC</sub> + 0.3	V
V <sub>BUS</sub>	DC input voltage at pins 11 and 12		-10	+27	V
V <sub>CANH</sub> , V <sub>CANL</sub>	DC input voltage at pins 11 and 12	V <sub>CC</sub> = 0 to 5.5 V; V <sub>BAT</sub> ≥ 0 V; t < 0.1 ms; load dump	-40	+40	V
V <sub>tr</sub>	transient voltage at pins 11 and 12	see Fig.6	-150	+100	V
V <sub>WAKE</sub>	DC input voltage on pin 7		-	V <sub>BAT</sub> + 0.3	V
I <sub>WAKE</sub>	input current pin 7		-15	-	mA
V <sub>1,8,9</sub>	DC input voltage on pins 1, 8 and 9		-0.3	V <sub>BAT</sub> + 0.3	V
V <sub>BAT</sub>	DC input voltage on pin 14		-0.3	+27	V
	voltage on pin 14	load dump; 500 ms	-	40	V
R <sub>8,9</sub>	termination resistances pins 8 and 9		500	16000	Ω
T <sub>vj</sub>	virtual junction temperature	note 1	-40	+150	°C
T <sub>stg</sub>	storage temperature		-55	+150	°C
V <sub>esd</sub>	electrostatic discharge voltage at any pin	note 2	-2000	+2000	V
		note 3	-200	+200	V

**Notes**

- Junction temperature in accordance with IEC 60747-1. An alternative definition is:  $T_{vj} = T_{amb} + PD \times R_{th\ vj-a}$ .  
Where:  $R_{th\ vj-a}$  is a fixed value to be used for the calculation of  $T_{vj}$ . The rating for  $T_{vj}$  limits the allowable combinations of power dissipation and ambient temperature.
- Human body model: equivalent to discharging a 100 pF capacitor through a 1.5 kΩ resistor.
- Machine model: equivalent to discharging a 200 pF capacitor through a 25 Ω resistor.

**THERMAL CHARACTERISTICS**

SYMBOL	PARAMETER	CONDITIONS	VALUE	UNIT
R <sub>th vj-a</sub>	thermal resistance from junction to ambient	in free air	120	K/W

**QUALITY SPECIFICATION**

Quality specification in accordance with "SNW-FQ-611-Part-E".

## Fault-tolerant CAN transceiver

TJA1053

**CHARACTERISTICS**

$V_{CC} = 4.75$  to  $5.25$  V;  $V_{\overline{STB}} = V_{CC}$ ;  $V_{BAT} = 6$  to  $27$  V;  $T_{amb} = -40$  to  $+125$  °C; all voltages are defined with respect to ground; positive currents flow into the IC; all parameters are guaranteed over the temperature range by design, but only 100% tested at 25 °C; unless otherwise specified.

SYMBOL	PARAMETER	CONDITIONS	MIN.	TYP.	MAX.	UNIT
<b>Supplies</b>						
$I_{CC}$	supply current	recessive; TXD = $V_{CC}$ ; normal operating mode	–	6	10	mA
		dominant; TXD = 0 V; no load; normal operating mode	–	29	35	mA
$I_{CC} + I_{BAT}$	supply current	$V_{CC}$ standby; $V_{CC} = 5$ V; $V_{BAT} = 12$ V; $T_{amb} < 90$ °C	–	200	500	µA
$I_{BAT} + I_{CC}$	supply current	$V_{BAT}$ standby; $V_{CC} = 5$ V; $V_{BAT} = 12$ V; $T_{amb} < 90$ °C	–	70	95	µA
$I_{BAT(sleep)}$	supply current	sleep mode; $V_{CC} = 0$ V; $V_{BAT} = 12$ V; $T_{amb} < 90$ °C	–	65	90	µA
$V_{BAT}$	battery voltage for setting power-on flag	low power modes	–	–	1.0	V
$t_{pwon}$	battery voltage low time for setting power-on flag	low power modes	1	–	–	s
<b>Pins <math>\overline{STB}</math>, EN and TXD</b>						
$V_{IH}$	HIGH-level input voltage		$0.7V_{CC}$	–	$V_{CC} + 0.3$	V
$V_{IL}$	LOW-level input voltage		–0.3	–	$0.3V_{CC}$	V
$I_{IH}$	HIGH-level input current (pins $\overline{STB}$ and EN)	$V_i = 4$ V	–	9	20	µA
$I_{IL}$	LOW-level input current (pins $\overline{STB}$ and EN)	$V_i = 1$ V	4	8	–	µA
$I_{IH}$	HIGH-level input current (pin TXD)	$V_i = 4$ V	–25	–80	–200	µA
$I_{IL}$	LOW-level input current (pin TXD)	$V_i = 1$ V	–100	–320	–800	µA
$V_{CC}$	forced $V_{BAT}$ standby mode (fail safe)		2.75	–	4.5	V
<b>Pins RXD and NERR</b>						
$V_{OH}$	HIGH-level output voltage (pin NERR)	$I_o = -100$ µA	$V_{CC} - 0.9$	–	$V_{CC}$	V
$V_{OH}$	HIGH-level output voltage (pin RXD)	$I_o = -250$ µA	$V_{CC} - 0.9$	–	$V_{CC}$	V
$V_{OL}$	LOW-level output voltage	$I_o = 1.25$ mA	0	–	0.9	V
<b>Pin WAKE</b>						
$I_{IL}$	LOW-level input current	$V_{WAKE} = 0$ V; $V_{BAT} = 27$ V	–70	–40	–10	µA
$V_{wu(th)}$	wake-up threshold voltage	$V_{\overline{STB}} = 0$ V	1.7	3.0	4.0	V



## Fault-tolerant CAN transceiver

TJA1053

SYMBOL	PARAMETER	CONDITIONS	MIN.	TYP.	MAX.	UNIT
<b>Pin INH</b>						
$V_{\text{dropH}}$	HIGH-level voltage drop	$I_{\text{INH}} = -0.18 \text{ mA}; V_{\text{BAT}} < 16 \text{ V}$	–	–	0.8	V
		$I_{\text{INH}} = -0.18 \text{ mA}; V_{\text{BAT}} > 16 \text{ V}$	–	–	1.0	V
$I_{\text{LI}}$	leakage current	sleep mode; $V_{\text{INH}} = 0 \text{ V}$	–5.0	–	+5.0	$\mu\text{A}$
<b>Pins CANH and CANL</b>						
$V_{\text{drx}}$	differential receiver threshold voltage	no bus failures bus failures 1, 2 and 5	–3.25	–	–2.65	V
$V_{\text{oCANHrec}}$	CANH recessive output voltage	$\text{TXD} = V_{\text{CC}}; R_{\text{RTH}} < 4 \text{ k}\Omega$	–	–	0.2	V
$V_{\text{oCANLrec}}$	CANL recessive output voltage	$\text{TXD} = V_{\text{CC}}; R_{\text{RTL}} < 4 \text{ k}\Omega$	$V_{\text{CC}} - 0.2$	–	–	V
$V_{\text{oCANHdom}}$	CANH dominant output voltage	$\text{TXD} = 0 \text{ V}; V_6 = V_{\text{CC}};$ $I_{\text{CANH}} = -40 \text{ mA}$	$V_{\text{CC}} - 1.4$	–	–	V
$V_{\text{oCANLdom}}$	CANL dominant output voltage	$\text{TXD} = 0 \text{ V}; V_6 = V_{\text{CC}};$ $I_{\text{CANL}} = 40 \text{ mA}$	–	–	1.4	V
$I_{\text{oCANH}}$	CANH output current	$V_{\text{CANH}} = 0 \text{ V}; \text{TXD} = 0 \text{ V}$	–	–75	–100	mA
		sleep mode; $V_{\text{CANH}} = 12 \text{ V}$	–	0	–	$\mu\text{A}$
$I_{\text{oCANL}}$	CANL output current	$V_{\text{CANL}} = 14 \text{ V}; \text{TXD} = 0 \text{ V}$	–	90	130	mA
		sleep mode; $V_{\text{CANL}} = 0 \text{ V};$ $V_{\text{BAT}} = 12 \text{ V}$	–	0	–	$\mu\text{A}$
$V_{\text{det(th)H,L}}$	voltage detection threshold for short-circuit to battery voltage on CANH and CANL	normal mode	6.5	7.3	8.0	V
$V_{\text{det(th)H}}$	voltage detection threshold for short-circuit to battery voltage on CANH	standby/sleep mode	$V_{\text{BAT}} - 2.5$	–	$V_{\text{BAT}} - 1$	V
$V_{\text{wuL}}$	CANL wake-up voltage threshold		2.4	3.1	3.8	V
$V_{\text{wuH}}$	CANH wake-up voltage threshold		1.2	1.9	2.7	V
$V_{\text{wuL}} - V_{\text{wuH}}$	wake-up voltage threshold difference		0.2	–	–	V
$V_{\text{CANH}}$	CANH single-ended receiver threshold	failures 4, 6 and 7	1.5	1.82	2.15	V
$V_{\text{CANL}}$	CANL single-ended receiver threshold voltage	failure 3	2.8	3.1	3.4	V

## Fault-tolerant CAN transceiver

TJA1053

SYMBOL	PARAMETER	CONDITIONS	MIN.	TYP.	MAX.	UNIT
<b>Pins RTH and RTL</b>						
R <sub>RTL</sub>	RTL to V <sub>CC</sub> switch-on resistance	I <sub>o</sub>   < 10 mA; normal operating mode	–	7	25	Ω
		I <sub>o</sub>   < 1 mA; V <sub>CC</sub> standby mode	–	15	75	Ω
	RTL to V <sub>BAT</sub> switch series resistance	V <sub>BAT</sub> standby or sleep mode	8	12.5	23	kΩ
R <sub>RTH</sub>	RTH to ground switch-on resistance	I <sub>o</sub>   < 10 mA; normal operating mode	–	43	95	Ω
V <sub>oRTH</sub>	RTH output voltage	I <sub>o</sub> = 1 mA; low power modes	–	0.7	1.0	V
I <sub>RTLpu</sub>	RTL pull-up current	normal operating mode, failures 4, 6 and 7	–	75	–	μA
I <sub>RTHpd</sub>	RTH pull-down current	normal operating mode, failure 3	–	75	–	μA
<b>Thermal shutdown</b>						
T <sub>jsd</sub>	shutdown junction temperature		155	165	180	°C

**AC CHARACTERISTICS**

V<sub>CC</sub> = 4.75 to 5.25 V; V<sub>STB</sub> = V<sub>CC</sub>; V<sub>BAT</sub> = 6 to 27 V; T<sub>amb</sub> = –40 to +125 °C; all voltages are defined with respect to ground; positive currents flow into the IC; all parameters are guaranteed over the temperature range by design, but only 100% tested at 25 °C; unless otherwise specified.

SYMBOL	PARAMETER	CONDITIONS	MIN.	TYP.	MAX.	UNIT
t <sub>t(r-d)</sub>	CANL and CANH bus output transition time recessive-to-dominant	10% to 90%; C1 = 10 nF; C2 = 0; R1 = 100 Ω	0.6	0.85	–	μs
t <sub>t(d-r)</sub>	CANL and CANH bus output transition time dominant-to-recessive	10% to 90%; C1 = 1 nF; C2 = 0; R1 = 100 Ω	0.3	0.4	–	μs
t <sub>PD(L)</sub>	propagation delay TXD-to-RXD LOW	C1 = 100 pF; C2 = 0; R1 = 100 Ω; no failures and bus failures 1, 2 and 5	–	0.75	1.25	μs
		C1 = C2 = 3.3 nF; R1 = 100 Ω; no failures and bus failures 1, 2 and 5	–	1	1.5	μs
		C1 = 100 pF; C2 = 0; R1 = 100 Ω; bus failures 3, 4, 6 and 7	–	0.85	1.3	μs
		C1 = C2 = 3.3 nF; R1 = 100 Ω; bus failures 3, 4, 6 and 7	–	1.1	1.7	μs

## Fault-tolerant CAN transceiver

## TJA1053

SYMBOL	PARAMETER	CONDITIONS	MIN.	TYP.	MAX.	UNIT
$t_{PD(H)}$	propagation delay TXD-to-RXD HIGH	C1 = 100 pF; C2 = 0; R1 = 100 $\Omega$ ; no failures and bus failures 1, 2 and 5	–	0.95	1.5	$\mu$ s
		C1 = C2 = 3.3 nF; R1 = 100 $\Omega$ ; no failures and bus failures 1 and 2	–	2.2	3.0	$\mu$ s
		C1 = 100 pF; C2 = 0; R1 = 100 $\Omega$ ; bus failures 3, 4, 6 and 7	–	0.85	1.3	$\mu$ s
		C1 = C2 = 3.3 nF; R1 = 100 $\Omega$ ; bus failures 3, 4, 5, 6 and 7	–	1.4	2.1	$\mu$ s
$t_{WU(min)}$	minimum dominant time for wake-up on CANL or CANH	low power modes $V_{BAT} = 12$ V	8	–	38	$\mu$ s
$t_{WAKE(min)}$	minimum $\overline{WAKE}$ LOW time for wake-up	low power modes $V_{BAT} = 12$ V	8	–	38	$\mu$ s
$t_{fail}$	failure 3 detection time	normal mode	10	–	60	$\mu$ s
	failure 6 detection time	normal mode	50	–	400	$\mu$ s
	failure 3 recovery time	normal mode	10	–	60	$\mu$ s
	failure 6 recovery time	normal mode	150	–	750	$\mu$ s
	failures 4 and 7 detection time	normal mode	0.75	–	4.0	ms
	failures 4 and 7 recovery time	normal mode	10	–	60	$\mu$ s
	failures 3, 4 and 7 detection time	low power modes; $V_{BAT} = 12$ V	0.8	–	8.0	ms
	failures 3, 4 and 7 recovery time	low power modes; $V_{BAT} = 12$ V	–	4	–	ms
$t_{TXD}$	TXD permanent dominant timer, disable time	normal mode and failure modes	0.75	–	4.0	ms
$t_h(min)$	minimum hold time to go to sleep command		5	–	50	$\mu$ s
$\Delta ec$	edge-count difference between CANH and CANL					
	for failures 1, 2 and 5 detection (NERR becomes LOW)	normal mode	–	3	–	
	for failures 1, 2 and 5 recovery	normal mode	–	1	–	

Fault-tolerant CAN transceiver

TJA1053

TEST AND APPLICATION INFORMATION

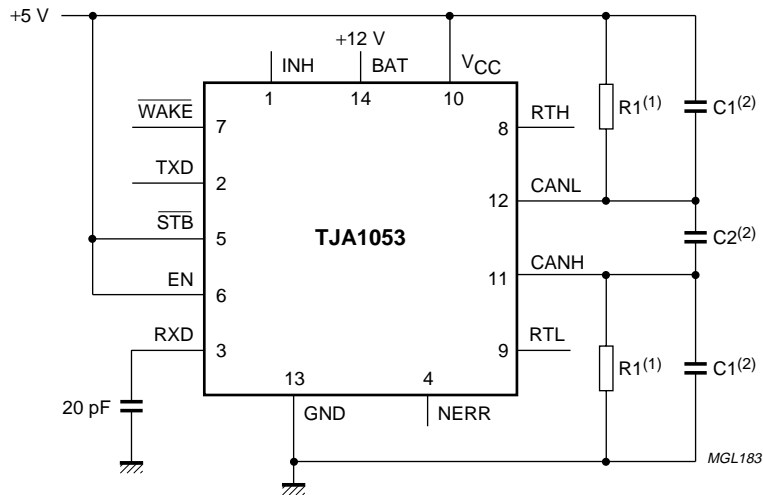

- (1) Termination resistors R1 (100 Ω) are not connected to RTH or RTL for testing purposes because the minimum load resistance allowed on the CAN bus line is 500 Ω per transceiver.
- (2) The capacitive bus load of 10 nF is split into three equal capacitors (3.3 nF) to simulate the CAN bus line.

Fig.3 Test circuit for dynamic characteristics.

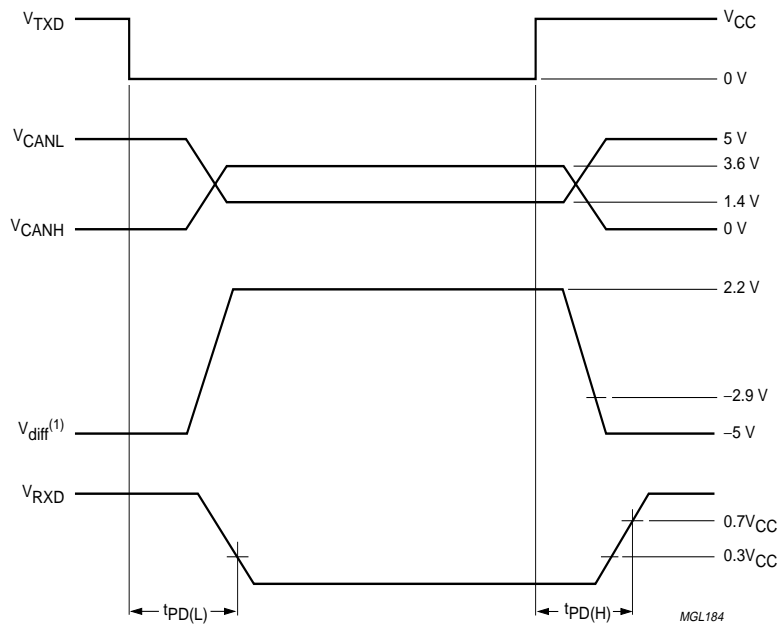

(1)  $V_{diff} = V_{CANH} - V_{CANL}$

Fig.4 Timing diagram for dynamic characteristics.

Fault-tolerant CAN transceiver

TJA1053

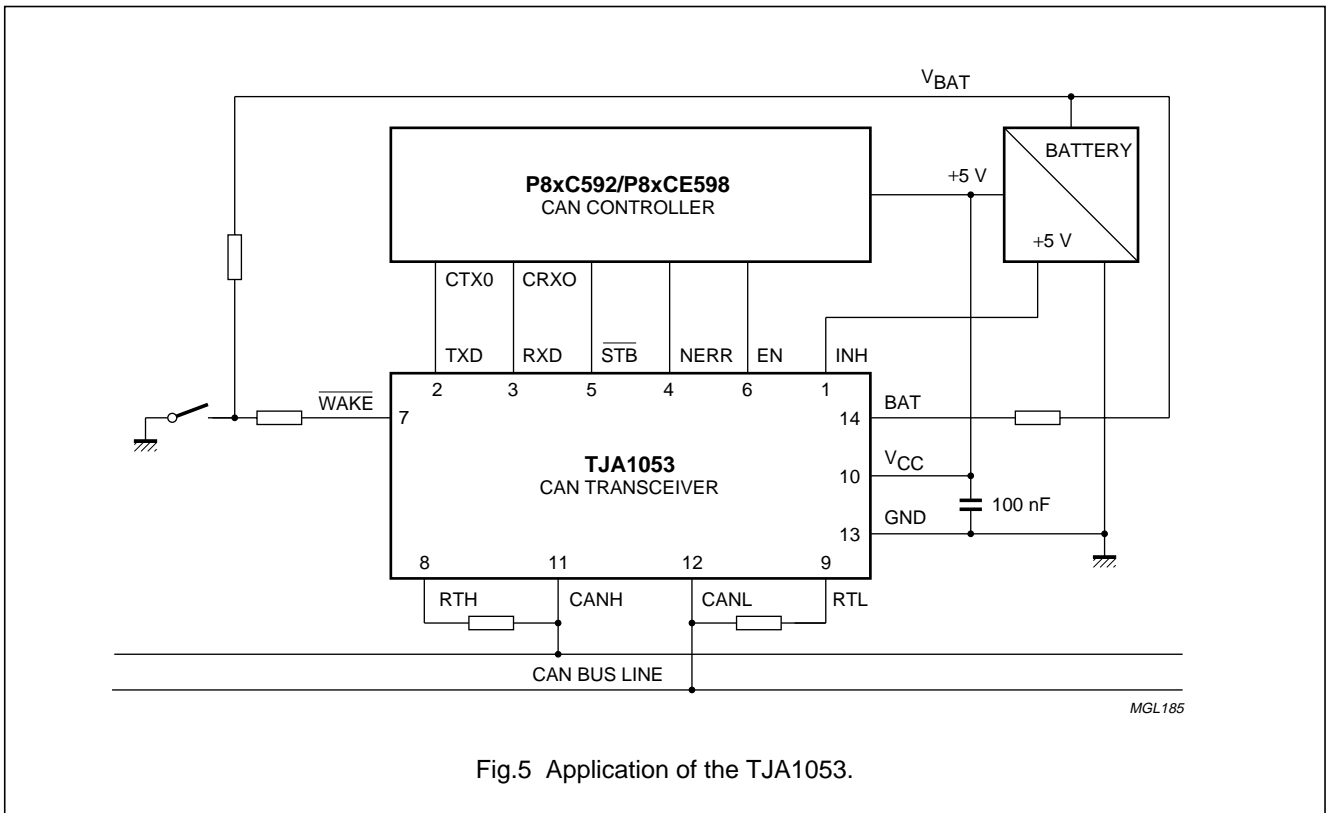
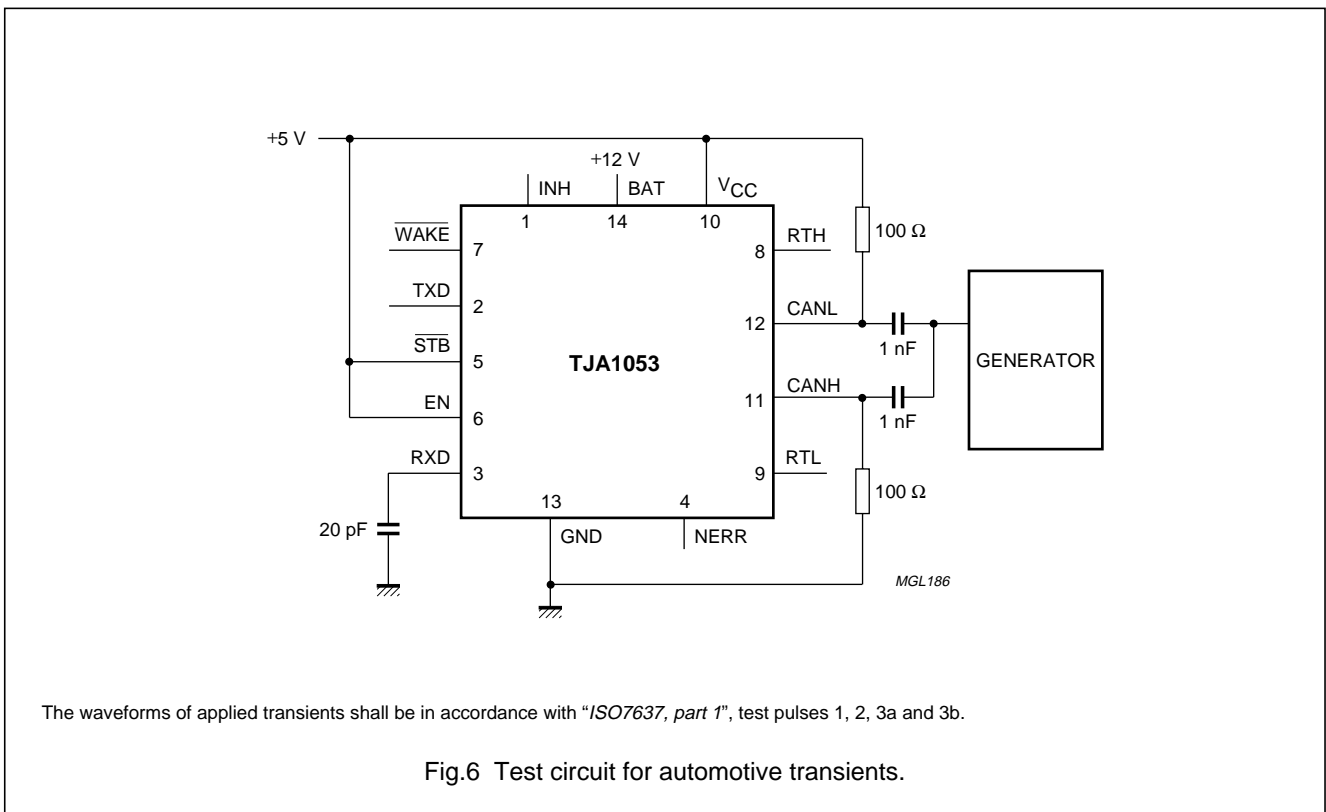

Fig.5 Application of the TJA1053.



The waveforms of applied transients shall be in accordance with "ISO7637, part 1", test pulses 1, 2, 3a and 3b.

Fig.6 Test circuit for automotive transients.

Fault-tolerant CAN transceiver

TJA1053

PACKAGE OUTLINE

SO14: plastic small outline package; 14 leads; body width 3.9 mm

SOT108-1

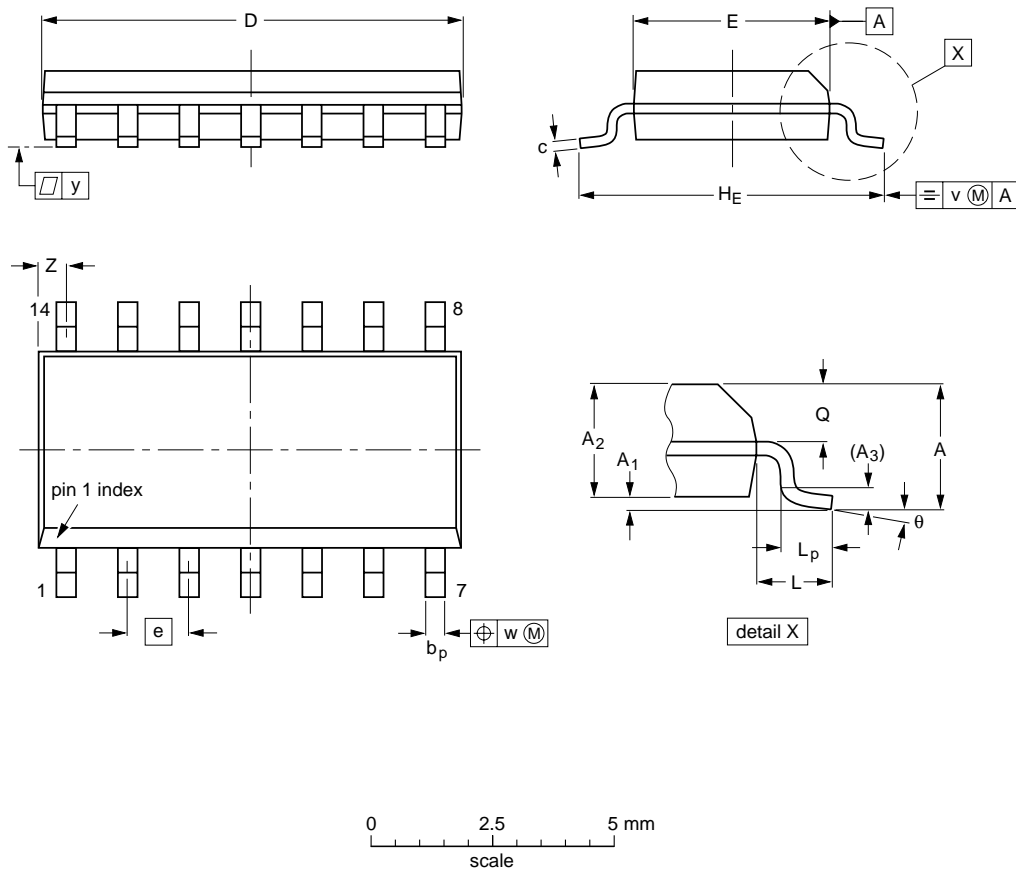

DIMENSIONS (inch dimensions are derived from the original mm dimensions)

UNIT	A max.	A <sub>1</sub>	A <sub>2</sub>	A <sub>3</sub>	b <sub>p</sub>	c	D <sup>(1)</sup>	E <sup>(1)</sup>	e	H <sub>E</sub>	L	L <sub>p</sub>	Q	v	w	y	Z <sup>(1)</sup>	θ
mm	1.75	0.25 0.10	1.45 1.25	0.25	0.49 0.36	0.25 0.19	8.75 8.55	4.0 3.8	1.27	6.2 5.8	1.05	1.0 0.4	0.7 0.6	0.25	0.25	0.1	0.7 0.3	8° 0°
inches	0.069	0.010 0.004	0.057 0.049	0.01	0.019 0.014	0.0100 0.0075	0.35 0.34	0.16 0.15	0.050	0.244 0.228	0.041	0.039 0.016	0.028 0.024	0.01	0.01	0.004	0.028 0.012	

Note

1. Plastic or metal protrusions of 0.15 mm maximum per side are not included.

OUTLINE VERSION	REFERENCES				EUROPEAN PROJECTION	ISSUE DATE
	IEC	JEDEC	EIAJ			
SOT108-1	076E06	MS-012				97-05-22 99-12-27

## Fault-tolerant CAN transceiver

TJA1053

### SOLDERING

#### Introduction to soldering surface mount packages

This text gives a very brief insight to a complex technology. A more in-depth account of soldering ICs can be found in our *"Data Handbook IC26; Integrated Circuit Packages"* (document order number 9398 652 90011).

There is no soldering method that is ideal for all surface mount IC packages. Wave soldering can still be used for certain surface mount ICs, but it is not suitable for fine pitch SMDs. In these situations reflow soldering is recommended.

#### Reflow soldering

Reflow soldering requires solder paste (a suspension of fine solder particles, flux and binding agent) to be applied to the printed-circuit board by screen printing, stencilling or pressure-syringe dispensing before package placement.

Several methods exist for reflowing; for example, convection or convection/infrared heating in a conveyor type oven. Throughput times (preheating, soldering and cooling) vary between 100 and 200 seconds depending on heating method.

Typical reflow peak temperatures range from 215 to 250 °C. The top-surface temperature of the packages should preferably be kept below 220 °C for thick/large packages, and below 235 °C for small/thin packages.

#### Wave soldering

Conventional single wave soldering is not recommended for surface mount devices (SMDs) or printed-circuit boards with a high component density, as solder bridging and non-wetting can present major problems.

To overcome these problems the double-wave soldering method was specifically developed.

If wave soldering is used the following conditions must be observed for optimal results:

- Use a double-wave soldering method comprising a turbulent wave with high upward pressure followed by a smooth laminar wave.
- For packages with leads on two sides and a pitch (e):
  - larger than or equal to 1.27 mm, the footprint longitudinal axis is **preferred** to be parallel to the transport direction of the printed-circuit board;
  - smaller than 1.27 mm, the footprint longitudinal axis **must** be parallel to the transport direction of the printed-circuit board.

The footprint must incorporate solder thieves at the downstream end.

- For packages with leads on four sides, the footprint must be placed at a 45° angle to the transport direction of the printed-circuit board. The footprint must incorporate solder thieves downstream and at the side corners.

During placement and before soldering, the package must be fixed with a droplet of adhesive. The adhesive can be applied by screen printing, pin transfer or syringe dispensing. The package can be soldered after the adhesive is cured.

Typical dwell time is 4 seconds at 250 °C.

A mildly-activated flux will eliminate the need for removal of corrosive residues in most applications.

#### Manual soldering

Fix the component by first soldering two diagonally-opposite end leads. Use a low voltage (24 V or less) soldering iron applied to the flat part of the lead. Contact time must be limited to 10 seconds at up to 300 °C.

When using a dedicated tool, all other leads can be soldered in one operation within 2 to 5 seconds between 270 and 320 °C.

Fault-tolerant CAN transceiver

TJA1053

Suitability of surface mount IC packages for wave and reflow soldering methods

PACKAGE	SOLDERING METHOD	
	WAVE	REFLOW <sup>(1)</sup>
BGA, HBGA, LFBGA, SQFP, TFBGA	not suitable	suitable
HBCC, HLQFP, HSQFP, HSOP, HTQFP, HTSSOP, HVQFN, SMS	not suitable <sup>(2)</sup>	suitable
PLCC <sup>(3)</sup> , SO, SOJ	suitable	suitable
LQFP, QFP, TQFP	not recommended <sup>(3)(4)</sup>	suitable
SSOP, TSSOP, VSO	not recommended <sup>(5)</sup>	suitable

Notes

1. All surface mount (SMD) packages are moisture sensitive. Depending upon the moisture content, the maximum temperature (with respect to time) and body size of the package, there is a risk that internal or external package cracks may occur due to vaporization of the moisture in them (the so called popcorn effect). For details, refer to the Drypack information in the *“Data Handbook IC26; Integrated Circuit Packages; Section: Packing Methods”*.
2. These packages are not suitable for wave soldering as a solder joint between the printed-circuit board and heatsink (at bottom version) can not be achieved, and as solder may stick to the heatsink (on top version).
3. If wave soldering is considered, then the package must be placed at a 45° angle to the solder wave direction. The package footprint must incorporate solder thieves downstream and at the side corners.
4. Wave soldering is only suitable for LQFP, TQFP and QFP packages with a pitch (e) equal to or larger than 0.8 mm; it is definitely not suitable for packages with a pitch (e) equal to or smaller than 0.65 mm.
5. Wave soldering is only suitable for SSOP and TSSOP packages with a pitch (e) equal to or larger than 0.65 mm; it is definitely not suitable for packages with a pitch (e) equal to or smaller than 0.5 mm.



## Fault-tolerant CAN transceiver

TJA1053

## DATA SHEET STATUS

DATA SHEET STATUS	PRODUCT STATUS	DEFINITIONS <sup>(1)</sup>
Objective specification	Development	This data sheet contains the design target or goal specifications for product development. Specification may change in any manner without notice.
Preliminary specification	Qualification	This data sheet contains preliminary data, and supplementary data will be published at a later date. Philips Semiconductors reserves the right to make changes at any time without notice in order to improve design and supply the best possible product.
Product specification	Production	This data sheet contains final specifications. Philips Semiconductors reserves the right to make changes at any time without notice in order to improve design and supply the best possible product.

## Note

1. Please consult the most recently issued data sheet before initiating or completing a design.

## DEFINITIONS

**Short-form specification** — The data in a short-form specification is extracted from a full data sheet with the same type number and title. For detailed information see the relevant data sheet or data handbook.

**Limiting values definition** — Limiting values given are in accordance with the Absolute Maximum Rating System (IEC 60134). Stress above one or more of the limiting values may cause permanent damage to the device. These are stress ratings only and operation of the device at these or at any other conditions above those given in the Characteristics sections of the specification is not implied. Exposure to limiting values for extended periods may affect device reliability.

**Application information** — Applications that are described herein for any of these products are for illustrative purposes only. Philips Semiconductors make no representation or warranty that such applications will be suitable for the specified use without further testing or modification.

## DISCLAIMERS

**Life support applications** — These products are not designed for use in life support appliances, devices, or systems where malfunction of these products can reasonably be expected to result in personal injury. Philips Semiconductors customers using or selling these products for use in such applications do so at their own risk and agree to fully indemnify Philips Semiconductors for any damages resulting from such application.

**Right to make changes** — Philips Semiconductors reserves the right to make changes, without notice, in the products, including circuits, standard cells, and/or software, described or contained herein in order to improve design and/or performance. Philips Semiconductors assumes no responsibility or liability for the use of any of these products, conveys no licence or title under any patent, copyright, or mask work right to these products, and makes no representations or warranties that these products are free from patent, copyright, or mask work right infringement, unless otherwise specified.

Fault-tolerant CAN transceiver

TJA1053

---

**NOTES**

Fault-tolerant CAN transceiver

TJA1053

---

**NOTES**

# Philips Semiconductors – a worldwide company

**Argentina:** see South America

**Australia:** 3 Figtree Drive, HOME BUSH, NSW 2140,  
Tel. +61 2 9704 8141, Fax. +61 2 9704 8139

**Austria:** Computerstr. 6, A-1101 WIEN, P.O. Box 213,  
Tel. +43 1 60 101 1248, Fax. +43 1 60 101 1210

**Belarus:** Hotel Minsk Business Center, Bld. 3, r. 1211, Volodarski Str. 6,  
220050 MINSK, Tel. +375 172 20 0733, Fax. +375 172 20 0773

**Belgium:** see The Netherlands

**Brazil:** see South America

**Bulgaria:** Philips Bulgaria Ltd., Energoproject, 15th floor,  
51 James Bourchier Blvd., 1407 SOFIA,  
Tel. +359 2 68 9211, Fax. +359 2 68 9102

**Canada:** PHILIPS SEMICONDUCTORS/COMPONENTS,  
Tel. +1 800 234 7381, Fax. +1 800 943 0087

**China/Hong Kong:** 501 Hong Kong Industrial Technology Centre,  
72 Tat Chee Avenue, Kowloon Tong, HONG KONG,  
Tel. +852 2319 7888, Fax. +852 2319 7700

**Colombia:** see South America

**Czech Republic:** see Austria

**Denmark:** Sydhavnsgade 23, 1780 COPENHAGEN V,  
Tel. +45 33 29 3333, Fax. +45 33 29 3905

**Finland:** Sinikalliontie 3, FIN-02630 ESPOO,  
Tel. +358 9 615 800, Fax. +358 9 6158 0920

**France:** 51 Rue Carnot, BP317, 92156 SURESNES Cedex,  
Tel. +33 1 4099 6161, Fax. +33 1 4099 6427

**Germany:** Hammerbrookstraße 69, D-20097 HAMBURG,  
Tel. +49 40 2353 60, Fax. +49 40 2353 6300

**Hungary:** see Austria

**India:** Philips INDIA Ltd, Band Box Building, 2nd floor,  
254-D, Dr. Annie Besant Road, Worli, MUMBAI 400 025,  
Tel. +91 22 493 8541, Fax. +91 22 493 0966

**Indonesia:** PT Philips Development Corporation, Semiconductors Division,  
Gedung Philips, Jl. Buncit Raya Kav.99-100, JAKARTA 12510,  
Tel. +62 21 794 0040 ext. 2501, Fax. +62 21 794 0080

**Ireland:** Newstead, Clonskeagh, DUBLIN 14,  
Tel. +353 1 7640 000, Fax. +353 1 7640 200

**Israel:** RAPAC Electronics, 7 Kehilat Saloniki St, PO Box 18053,  
TEL AVIV 61180, Tel. +972 3 645 0444, Fax. +972 3 649 1007

**Italy:** PHILIPS SEMICONDUCTORS, Via Casati, 23 - 20052 MONZA (MI),  
Tel. +39 039 203 6838, Fax +39 039 203 6800

**Japan:** Philips Bldg 13-37, Kohnan 2-chome, Minato-ku,  
TOKYO 108-8507, Tel. +81 3 3740 5130, Fax. +81 3 3740 5057

**Korea:** Philips House, 260-199 Itaewon-dong, Yongsan-ku, SEOUL,  
Tel. +82 2 709 1412, Fax. +82 2 709 1415

**Malaysia:** No. 76 Jalan Universiti, 46200 PETALING JAYA, SELANGOR,  
Tel. +60 3 750 5214, Fax. +60 3 757 4880

**Mexico:** 5900 Gateway East, Suite 200, EL PASO, TEXAS 79905,  
Tel. +9-5 800 234 7381, Fax +9-5 800 943 0087

**Middle East:** see Italy

**Netherlands:** Postbus 90050, 5600 PB EINDHOVEN, Bldg. VB,  
Tel. +31 40 27 82785, Fax. +31 40 27 88399

**New Zealand:** 2 Wagener Place, C.P.O. Box 1041, AUCKLAND,  
Tel. +64 9 849 4160, Fax. +64 9 849 7811

**Norway:** Box 1, Manglerud 0612, OSLO,  
Tel. +47 22 74 8000, Fax. +47 22 74 8341

**Pakistan:** see Singapore

**Philippines:** Philips Semiconductors Philippines Inc.,  
106 Valero St. Salcedo Village, P.O. Box 2108 MCC, MAKATI,  
Metro MANILA, Tel. +63 2 816 6380, Fax. +63 2 817 3474

**Poland:** Al.Jerozolimskie 195 B, 02-222 WARSAW,  
Tel. +48 22 5710 000, Fax. +48 22 5710 001

**Portugal:** see Spain

**Romania:** see Italy

**Russia:** Philips Russia, Ul. Usatcheva 35A, 119048 MOSCOW,  
Tel. +7 095 755 6918, Fax. +7 095 755 6919

**Singapore:** Lorong 1, Toa Payoh, SINGAPORE 319762,  
Tel. +65 350 2538, Fax. +65 251 6500

**Slovakia:** see Austria

**Slovenia:** see Italy

**South Africa:** S.A. PHILIPS Pty Ltd., 195-215 Main Road Martindale,  
2092 JOHANNESBURG, P.O. Box 58088 Newville 2114,  
Tel. +27 11 471 5401, Fax. +27 11 471 5398

**South America:** Al. Vicente Pinzon, 173, 6th floor,  
04547-130 SÃO PAULO, SP, Brazil,  
Tel. +55 11 821 2333, Fax. +55 11 821 2382

**Spain:** Balmes 22, 08007 BARCELONA,  
Tel. +34 93 301 6312, Fax. +34 93 301 4107

**Sweden:** Kottbygatan 7, Akalla, S-16485 STOCKHOLM,  
Tel. +46 8 5985 2000, Fax. +46 8 5985 2745

**Switzerland:** Allmendstrasse 140, CH-8027 ZÜRICH,  
Tel. +41 1 488 2741 Fax. +41 1 488 3263

**Taiwan:** Philips Semiconductors, 5F, No. 96, Chien Kuo N. Rd., Sec. 1,  
TAIPEI, Taiwan Tel. +886 2 2134 2451, Fax. +886 2 2134 2874

**Thailand:** PHILIPS ELECTRONICS (THAILAND) Ltd.,  
60/14 MOO 11, Bangna Trad Road KM. 3, Bagna, BANGKOK 10260,  
Tel. +66 2 361 7910, Fax. +66 2 398 3447

**Turkey:** Yukari Dudullu, Org. San. Blg., 2.Cad. Nr. 28 81260 Umraniye,  
ISTANBUL, Tel. +90 216 522 1500, Fax. +90 216 522 1813

**Ukraine:** PHILIPS UKRAINE, 4 Patrice Lumumba str., Building B, Floor 7,  
252042 KIEV, Tel. +380 44 264 2776, Fax. +380 44 268 0461

**United Kingdom:** Philips Semiconductors Ltd., 276 Bath Road, Hayes,  
MIDDLESEX UB3 5BX, Tel. +44 208 730 5000, Fax. +44 208 754 8421

**United States:** 811 East Arques Avenue, SUNNYVALE, CA 94088-3409,  
Tel. +1 800 234 7381, Fax. +1 800 943 0087

**Uruguay:** see South America

**Vietnam:** see Singapore

**Yugoslavia:** PHILIPS, Trg N. Pasica 5/v, 11000 BEOGRAD,  
Tel. +381 11 3341 299, Fax.+381 11 3342 553

**For all other countries apply to:** Philips Semiconductors,  
Marketing Communications, Building BE-p, P.O. Box 218, 5600 MD EINDHOVEN,  
The Netherlands, Fax. +31 40 27 24825

**Internet:** <http://www.semiconductors.philips.com>

© Philips Electronics N.V. 2000

SCA 70

All rights are reserved. Reproduction in whole or in part is prohibited without the prior written consent of the copyright owner.

The information presented in this document does not form part of any quotation or contract, is believed to be accurate and reliable and may be changed without notice. No liability will be accepted by the publisher for any consequence of its use. Publication thereof does not convey nor imply any license under patent- or other industrial or intellectual property rights.

Printed in The Netherlands

703502/02/pp20

Date of release: 2000 Dec 18

Document order number: 9397 750 07796

*Let's make things better.*

**Philips**  
Semiconductors



**PHILIPS**