
Features

- Supply Voltage: 4.5 V to 5.5 V
- Automatic Sensitivity Adaptation (AGC)
- Automatic Strong Signal Adaptation (ATC)
- Carrier Frequency is 56 kHz; Adjusted by Zener Diode Fusing $\pm 4\%$
- TTL and CMOS Compatible

Applications

- All Kinds of IR Remote Control Systems
- Carrier Frequency Modulated Transmission Systems

Benefits

- No External Components Needed
- Enhanced Immunity Against Ambient Light Disturbances

Description

The IC ATA2516 is a complete IR receiver for data communication systems. The device is developed and optimized for use in carrier frequency modulated transmission applications. Its function can be described using the block diagram in Figure 1 on page 2. The input stage meets two main functions. First, it provides a suitable bias voltage for the PIN diode. Secondly, the pulsed photo current signals are transformed into a voltage by a special circuit which is optimized for low noise application. After amplification by a Controlled Gain Amplifier (CGA), the signals pass a tuned integrated narrow bandpass filter with a center frequency f_0 equivalent to the chosen carrier frequency of the input signal. The demodulator is used to convert the input burst signal to a digital envelope output pulse and to evaluate the signal information quality, i.e., unwanted pulses will be suppressed at the output pin. All this is done by means of an integrated dynamic feedback circuit which varies the gain as a function of changing environmental conditions (ambient light, modulated lamps etc.). A 7-bit digital-to-analog converter is used to adjust the gain of the controlled gain amplifier. Other special features serve to adapt to the current application to secure best transmission quality. The ATA2516 operates in a voltage supply range of 4.5 V - 5.5 V.



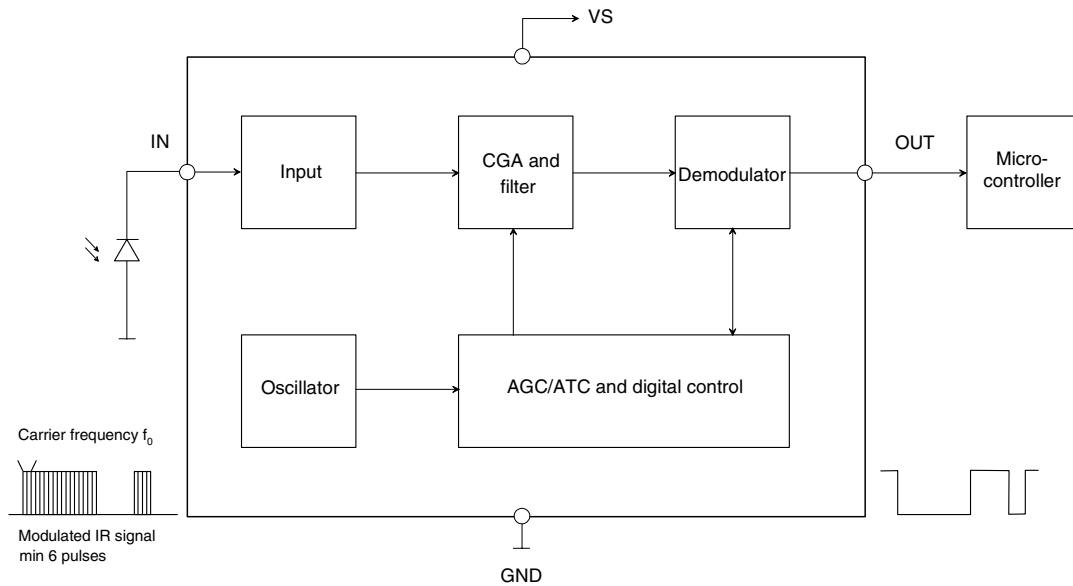
IR Receiver ASIC

ATA2516

Rev. 4801B-AUTO-10/04

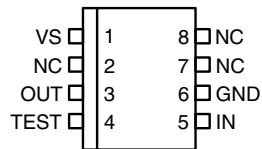


Figure 1. Block Diagram



Pin Configuration

Figure 2. Pinning TSSOP8



Pin Description

Pin	Symbol	Function
1	VS	Supply voltage
2	NC	Not connected
3	OUT	Data output
4	TEST	Test signal (not connected or connected to GND)
5	IN	Input PIN diode
6	GND	Ground
7	NC	Not connected
8	NC	Not connected

Absolute Maximum Ratings

Stresses beyond those listed under “Absolute Maximum Ratings” may cause permanent damage to the device. This is a stress rating only and functional operation of the device at these or any other conditions beyond those indicated in the operational sections of this specification is not implied. Exposure to absolute maximum rating conditions for extended periods may affect device reliability.

Parameters	Symbol	Value	Unit
Supply voltage	V_S	-0.3 to 6	V
Supply current (DC current $I_{IN_DC} = 0$)	I_S	0.5	mA
Input voltage	V_{IN}	-0.3 to V_S	V
Input DC current at $V_S = 5$ V	I_{IN_DC}	0.8	mA
Output voltage	V_O	-0.3 to V_S	V
Operating temperature	T_{amb}	-40 to +85	°C
Storage temperature	T_{stg}	-40 to +125	°C
Power dissipation at $T_{amb} = 25^\circ\text{C}$	P_{tot}	10	mW

Thermal Resistance

Parameters	Symbol	Value	Unit
Junction ambient TSSOP8	R_{thJA}	TBD	K/W

Electrical Characteristics

$T_{amb} = 25^\circ\text{C}$, $V_S = 5$ V unless otherwise specified.

No.	Parameters	Test Conditions	Pin	Symbol	Min.	Typ.	Max.	Unit	Type*
1	Supply								
1.1	Supply-voltage range		1	V_S	4.5	5	5.5	V	C
1.2	Supply current	$I_{IN_DC} = 0$; see Figure 6 on page 7	1	I_S		0.29	0.34	mA	A
1.3	Supply current	$I_{IN_DC} = 0$; see Figure 6 on page 7 $T_{amb} = -40^\circ\text{C}$ to 85°C	1	I_S			0.4	mA	B
2	Output								
2.1	Internal pull-up resistor	$T_{amb} = 25^\circ\text{C}$; see Figure 3 on page 5	1, 3	R_{PU}	65	100	135	k Ω	A
2.2	Output voltage low	$R_{Load} = 2.4$ k Ω	3, 6	V_{OL}		100	250	mV	A
2.3	Output voltage high		3, 1	V_{OH}	$V_S - 0.25$		V_S	V	A
3	Input								
3.1	Maximum input DC current	$V_{IN} = 0$; see Figure 8 on page 7	5	I_{IN_DCMAX}	580	760		μA	A
3.2	Maximum input DC current	$V_{IN} = 0$; $T_{amb} = 85^\circ\text{C}$	5	I_{IN_DCMAX}	490	650		μA	C
3.3	Number of pulses required		5		6				A

*) Type means: A = 100% tested, B = 100% correlation tested, C = Characterized on samples, D = Design parameter

Note: BER = bit error rate; e.g. BER = 5% means that with P = 20 at the input pins 19 to 21, pulses may appear at the OUT pin.

Electrical Characteristics (Continued)

$T_{amb} = 25^{\circ}\text{C}$, $V_S = 5\text{ V}$ unless otherwise specified.

No.	Parameters	Test Conditions	Pin	Symbol	Min.	Typ.	Max.	Unit	Type*
3.4	Minimum detection threshold current	Test signal: see Figure 4 on page 6 $V_S = 5\text{ V}$, $T_{amb} = 25^{\circ}\text{C}$, $I_{IN_DC} = 0\text{ }\mu\text{A}$; square pp, burst $N = 6$, $f = f_0$; $t_{PER} = 5\text{ ms}$, Figure 7; BER = 80%	5	I_{Eemin}	2.5	4	6.4	nA	A
3.5	Minimum detection threshold current	Test signal: see Figure 4 on page 6 $V_S = 5\text{ V}$, $T_{amb} = 25^{\circ}\text{C}$, $I_{IN_DC} = 650\text{ }\mu\text{A}$; square pp, burst $N = 6$, $f = f_0$; $t_{PER} = 5\text{ ms}$, Figure 7; BER = 80%	5	I_{Eemin}	20	30	60	nA	A
3.6	Photodiode input capacitance	$V_{IN} = 0$	5, 6			70		pF	D
4	Controlled Amplifier and Filter								
4.1	Center frequency of bandpass		3	f_0		56		kHz	A
4.2	Center frequency zapping accuracy of bandpass	$f_0 = 56\text{ kHz}$	3	f_{0ZAPP}	-4	f_0	+4	%	A
4.3	Overall accuracy center frequency of bandpass	$T_{amb} = -40^{\circ}\text{C}$ to 85°C	3	f_{0tol}	-10	f_0	+7	%	C
4.4	BPF bandwidth	-3 dB; $f_0 = 56\text{ kHz}$; see Figure 9 on page 8	3	B	4	8	14	kHz	C
4.5	Quiescent value of gain control counter	$V_{IN} = 0$; $I_{IN_DC} = 0$				20			A
4.6	Single gain step					0.35		dB/c	
4.7	Switch-on delay	$V_S = 5\text{ V}$, $T_{amb} = 25^{\circ}\text{C}$, $I_{IN} = 20\text{ nA pp}$, $N = 6$	3	t_{don}	4	6	8	Per	A
4.8	Pulse width	$V_S = 5\text{ V}$, $T_{amb} = 25^{\circ}\text{C}$, $I_{IN} = 20\text{ nA pp}$, $N = 6$	3	t_{po}	4	8	11	Per	A

*) Type means: A = 100% tested, B = 100% correlation tested, C = Characterized on samples, D = Design parameter

Note: BER = bit error rate; e.g. BER = 5% means that with $P = 20$ at the input pins 19 to 21, pulses may appear at the OUT pin.

ESD All pins: 1500 V HBM; 100 MM, MIL-STD-883C, Method 3015.7

Latch-up According JEDEC78 Class2 (HT)

Reliability HTOL (1000 h) at $T_j = 150^{\circ}\text{C}$ in molded TSSOP8 plastic package (2 lots)

Burn-in With 800 samples from 2 lots

Figure 3. Application Circuit

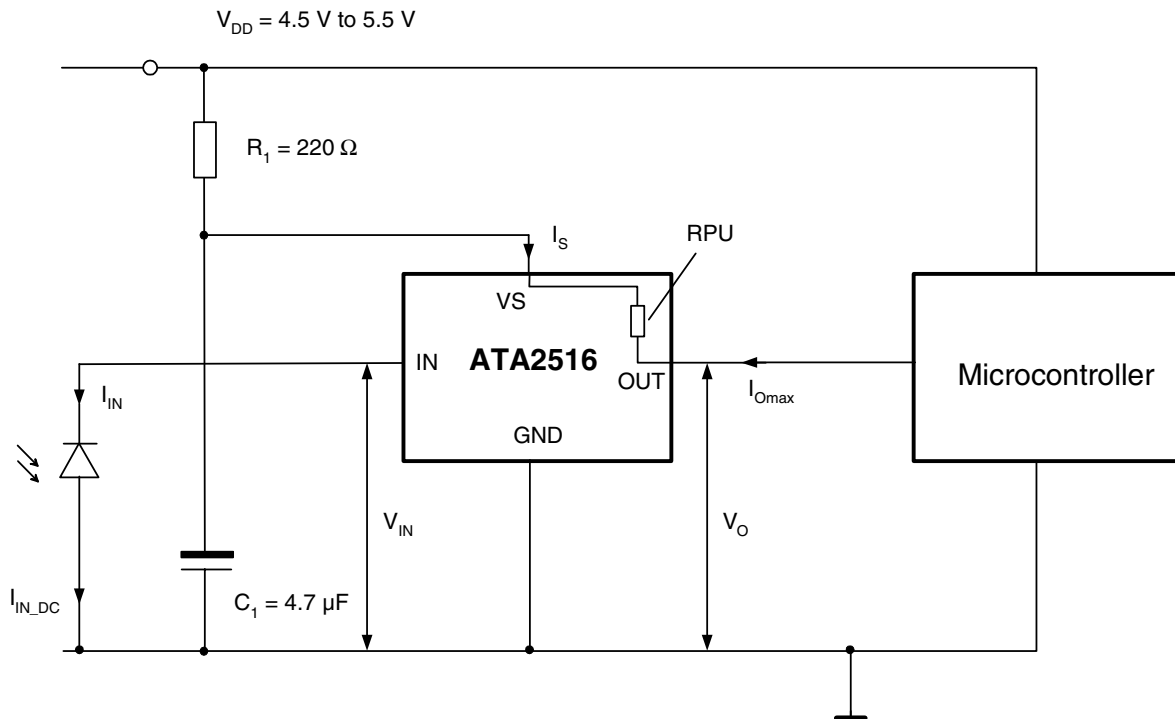


Figure 4. Test Circuit

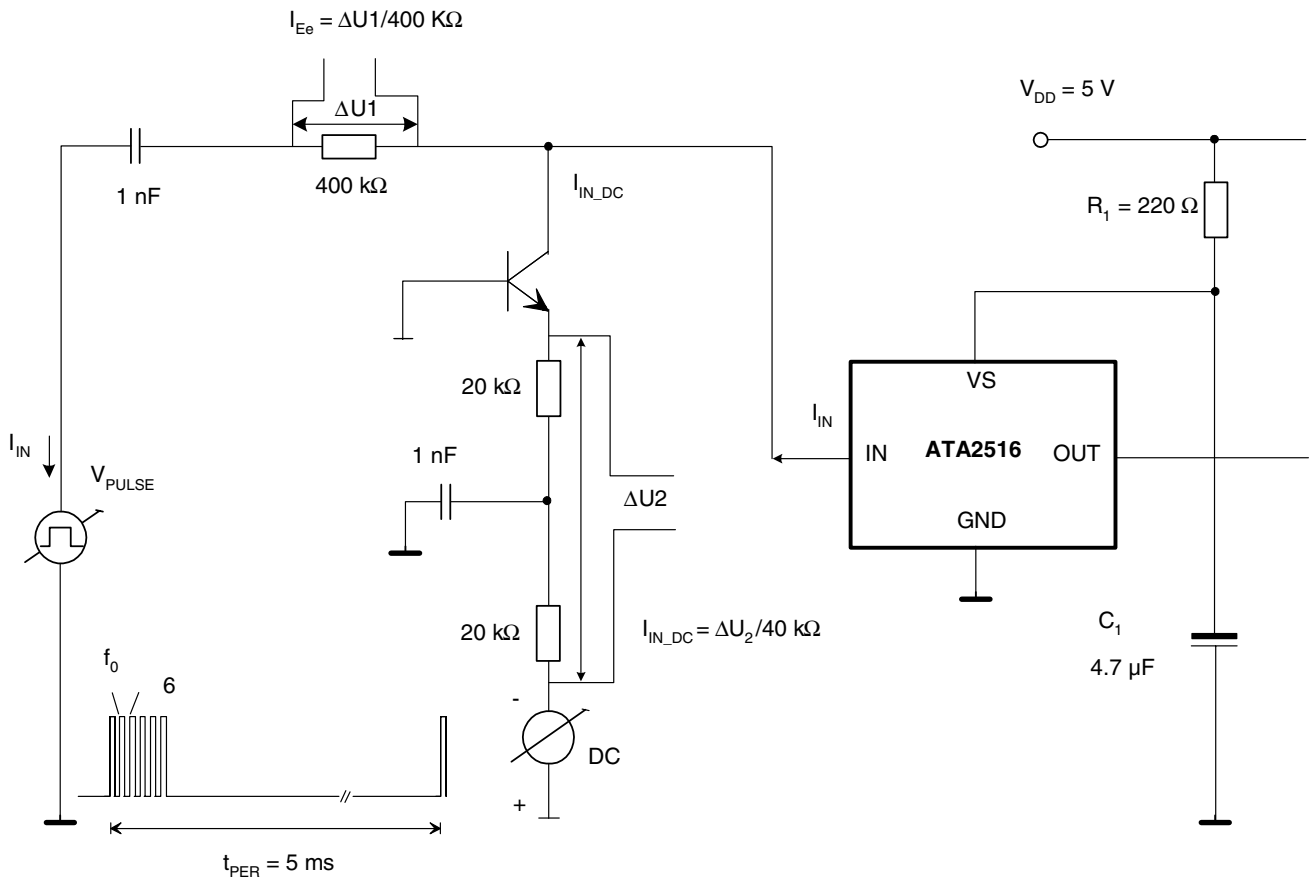
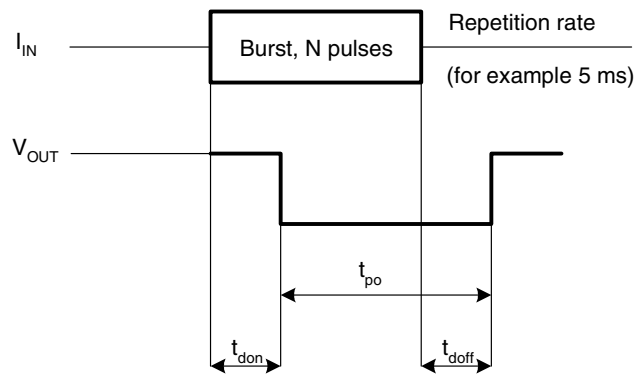


Figure 5. Pulse Diagram



Typical Electrical Curves

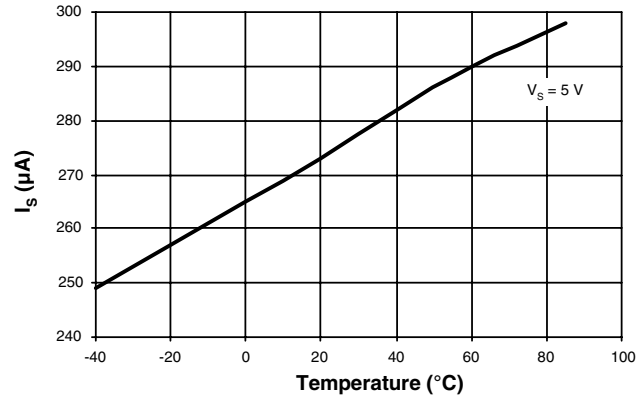
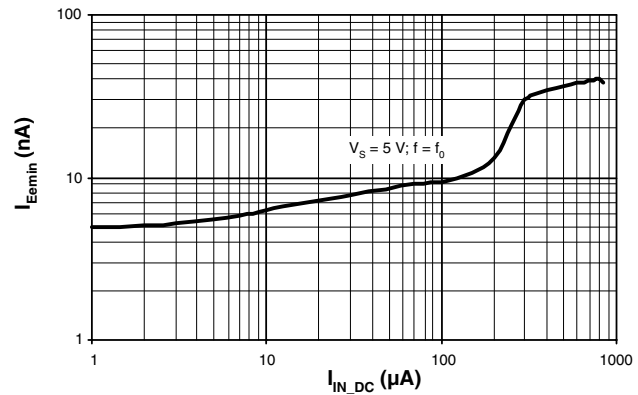
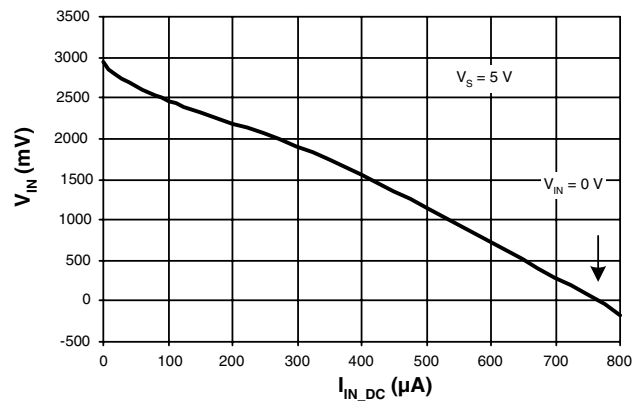
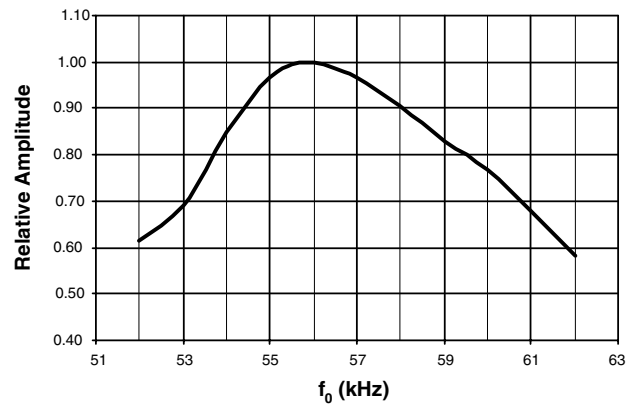
Figure 6. I_S versus Temperature, $V_S = 5\text{ V}$ Figure 7. I_{Emin} versus I_{IN_DC} , $V_S = 5\text{ V}$, $T_{amb} = 25^\circ\text{C}$ Figure 8. V_{IN} versus I_{IN_DC} , $V_S = 5\text{ V}$, $T_{amb} = 25^\circ\text{C}$ 

Figure 9. Typical Bandpass Curve at $T_{amb} = 25^{\circ}\text{C}$



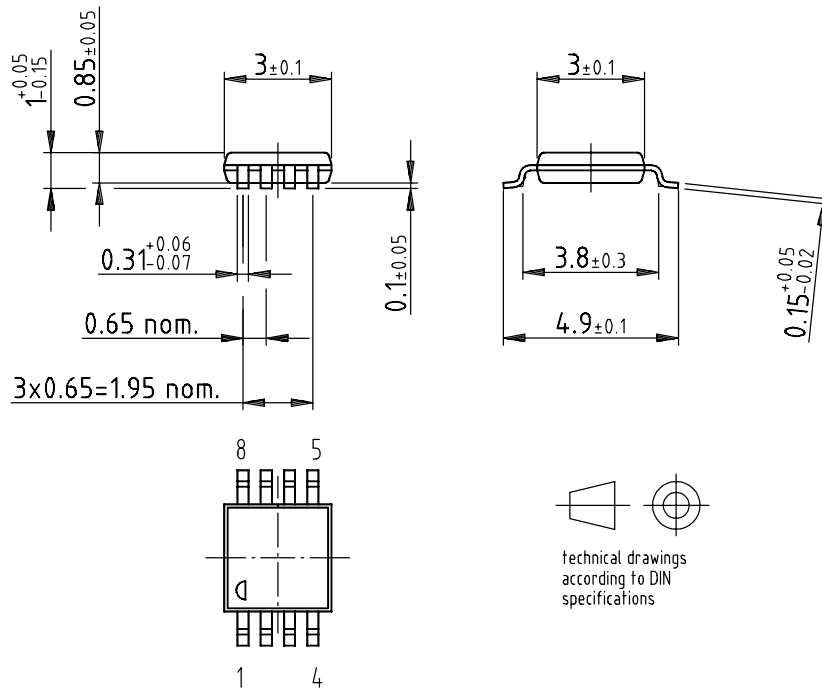
Ordering Information

Extended Type Number	Package	Remarks
ATA2516-6AQ	TSSOP8	IR receiver

Package Information

Package: TSSOP 8L

Dimensions in mm



Drawing-No.: 6.543-5083.01-4

Issue: 1; 08.01.02



Atmel Corporation

2325 Orchard Parkway
San Jose, CA 95131, USA
Tel: 1(408) 441-0311
Fax: 1(408) 487-2600

Regional Headquarters

Europe

Atmel Sarl
Route des Arsenaux 41
Case Postale 80
CH-1705 Fribourg
Switzerland
Tel: (41) 26-426-5555
Fax: (41) 26-426-5500

Asia

Room 1219
Chinachem Golden Plaza
77 Mody Road Tsimshatsui
East Kowloon
Hong Kong
Tel: (852) 2721-9778
Fax: (852) 2722-1369

Japan

9F, Tonetsu Shinkawa Bldg.
1-24-8 Shinkawa
Chuo-ku, Tokyo 104-0033
Japan
Tel: (81) 3-3523-3551
Fax: (81) 3-3523-7581

Atmel Operations

Memory

2325 Orchard Parkway
San Jose, CA 95131, USA
Tel: 1(408) 441-0311
Fax: 1(408) 436-4314

Microcontrollers

2325 Orchard Parkway
San Jose, CA 95131, USA
Tel: 1(408) 441-0311
Fax: 1(408) 436-4314

La Chantreterie
BP 70602
44306 Nantes Cedex 3, France
Tel: (33) 2-40-18-18-18
Fax: (33) 2-40-18-19-60

ASIC/ASSP/Smart Cards

Zone Industrielle
13106 Rousset Cedex, France
Tel: (33) 4-42-53-60-00
Fax: (33) 4-42-53-60-01

1150 East Cheyenne Mtn. Blvd.
Colorado Springs, CO 80906, USA
Tel: 1(719) 576-3300
Fax: 1(719) 540-1759

Scottish Enterprise Technology Park
Maxwell Building
East Kilbride G75 0QR, Scotland
Tel: (44) 1355-803-000
Fax: (44) 1355-242-743

RF/Automotive

Theresienstrasse 2
Postfach 3535
74025 Heilbronn, Germany
Tel: (49) 71-31-67-0
Fax: (49) 71-31-67-2340

1150 East Cheyenne Mtn. Blvd.
Colorado Springs, CO 80906, USA
Tel: 1(719) 576-3300
Fax: 1(719) 540-1759

Biometrics/Imaging/Hi-Rel MPU/ High Speed Converters/RF Datacom

Avenue de Rochepleine
BP 123
38521 Saint-Egreve Cedex, France
Tel: (33) 4-76-58-30-00
Fax: (33) 4-76-58-34-80

Literature Requests

www.atmel.com/literature

Disclaimer: The information in this document is provided in connection with Atmel products. No license, express or implied, by estoppel or otherwise, to any intellectual property right is granted by this document or in connection with the sale of Atmel products. **EXCEPT AS SET FORTH IN ATMEL'S TERMS AND CONDITIONS OF SALE LOCATED ON ATMEL'S WEB SITE, ATMEL ASSUMES NO LIABILITY WHATSOEVER AND DISCLAIMS ANY EXPRESS, IMPLIED OR STATUTORY WARRANTY RELATING TO ITS PRODUCTS INCLUDING, BUT NOT LIMITED TO, THE IMPLIED WARRANTY OF MERCHANTABILITY, FITNESS FOR A PARTICULAR PURPOSE, OR NON-INFRINGEMENT. IN NO EVENT SHALL ATMEL BE LIABLE FOR ANY DIRECT, INDIRECT, CONSEQUENTIAL, PUNITIVE, SPECIAL OR INCIDENTAL DAMAGES (INCLUDING, WITHOUT LIMITATION, DAMAGES FOR LOSS OF PROFITS, BUSINESS INTERRUPTION, OR LOSS OF INFORMATION) ARISING OUT OF THE USE OR INABILITY TO USE THIS DOCUMENT, EVEN IF ATMEL HAS BEEN ADVISED OF THE POSSIBILITY OF SUCH DAMAGES.** Atmel makes no representations or warranties with respect to the accuracy or completeness of the contents of this document and reserves the right to make changes to specifications and product descriptions at any time without notice. Atmel does not make any commitment to update the information contained herein. Atmel's products are not intended, authorized, or warranted for use as components in applications intended to support or sustain life.

© Atmel Corporation 2004. All rights reserved. Atmel®, logo and combinations thereof are registered trademarks, and Everywhere You AreSM are the trademarks of Atmel Corporation or its subsidiaries. Other terms and product names may be trademarks of others.



Printed on recycled paper.

4801B-AUTO-10/04