

## FIN1022 2 X 2 LVDS High Speed Crosspoint Switch

### General Description

This non-blocking 2x2 crosspoint switch has a fully differential input to output data path for low noise generation and low pulse width distortion. The device can be used as a high speed crosspoint switch, 2:1 multiplexer, 1:2 demultiplexer or 1:2 signal splitter. The inputs can directly interface with LVDS and LVPECL levels.

### Features

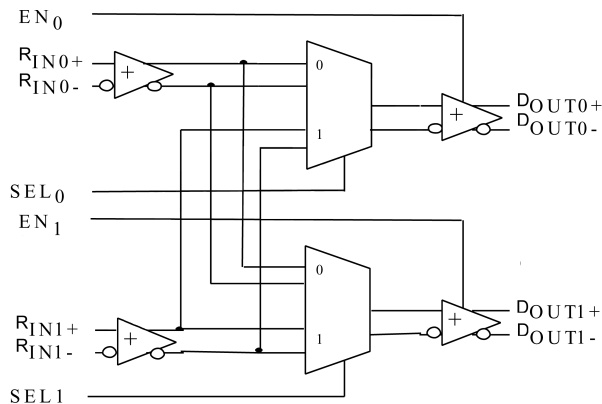
- Low jitter, 800 Mbps full differential data path
- Worst case jitter of 190ps  
with PRBS =  $2^{23} - 1$  data pattern at 800 Mbps
- Rail-to-rail common mode range is 0.5V to 3.25V
- Worst case power dissipation is less than 126 mW
- Open-circuit fail safe protection
- Fast switch time of 1.1 ns typical
- 35 ps typical pin channel to channel skew
- 3.3V power supply operation
- Non-blocking switch
- LVDS receiver inputs accept LVPECL signals directly
- 7.5 kV HBM ESD protection
- 16-lead SOIC package and TSSOP package
- Inter-operates with TIA/EIA 644-1995 specification
- See the Fairchild Interface Solutions web page for cross reference information:  
[www.fairchildsemi.com/products/interface/lvds.html](http://www.fairchildsemi.com/products/interface/lvds.html)

### Ordering Code:

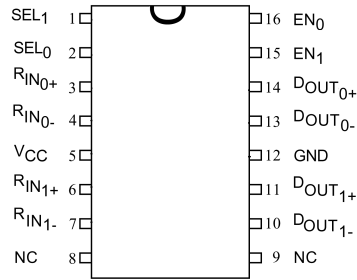
Order Number	Package Number	Package Description
FIN1022M	M16A	16-Lead Small Outline Integrated Circuit (SOIC), JEDEC MS-012, 0.150" Narrow
FIN1022MTC	MTC16	16-Lead Thin Shrink Small Outline Package (TSSOP), JEDEC MO-153, 4.4mm Wide

Devices also available in Tape and Reel. Specify by appending suffix letter "X" to the ordering code.

### Logic Symbol



### Connection Diagram



### Pin Descriptions

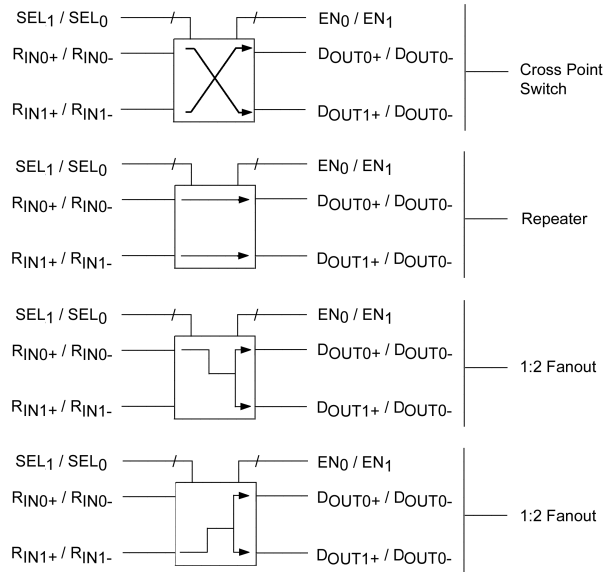
Pin Name	Description
R <sub>IN0+</sub> , R <sub>IN1+</sub>	LVDS non-inverting data inputs
R <sub>IN0-</sub> , R <sub>IN1-</sub>	LVDS inverting data inputs
D <sub>OUT0+</sub> , D <sub>OUT1+</sub>	LVDS non-inverting data outputs
D <sub>OUT0-</sub> , D <sub>OUT1-</sub>	LVDS inverting data outputs
EN <sub>0</sub>	LVTTTL input for enabling D <sub>OUT0+</sub> /D <sub>OUT0-</sub>
EN <sub>1</sub>	LVTTTL input for enabling D <sub>OUT1+</sub> /D <sub>OUT1-</sub>
SEL <sub>0</sub>	LVTTTL input for selecting R <sub>IN0+</sub> /R <sub>IN0-</sub> or R <sub>IN1+</sub> /R <sub>IN1-</sub> for output D <sub>OUT0+</sub> /D <sub>OUT0-</sub>
SEL <sub>1</sub>	LVTTTL input for selecting R <sub>IN0+</sub> /R <sub>IN0-</sub> or R <sub>IN1+</sub> /R <sub>IN1-</sub> for output D <sub>OUT1+</sub> /D <sub>OUT1-</sub>
V <sub>CC</sub>	Power Supply
GND	Ground

### Function Table

Inputs				Outputs				Mode
SEL <sub>0</sub>	SEL <sub>1</sub>	EN <sub>0</sub>	EN <sub>1</sub>	D <sub>OUT0+</sub>	D <sub>OUT0-</sub>	D <sub>OUT1+</sub>	D <sub>OUT1-</sub>	
L/O	L/O	H	H	R <sub>IN0+</sub>	R <sub>IN0-</sub>	R <sub>IN0+</sub>	R <sub>IN0-</sub>	1:2 Splitter
L/O	H	H	H	R <sub>IN0+</sub>	R <sub>IN0-</sub>	R <sub>IN1+</sub>	R <sub>IN1-</sub>	Repeater
H	L/O	H	H	R <sub>IN1+</sub>	R <sub>IN1-</sub>	R <sub>IN0+</sub>	R <sub>IN0-</sub>	Switch
H	H	H	H	R <sub>IN1+</sub>	R <sub>IN1-</sub>	R <sub>IN1+</sub>	R <sub>IN1-</sub>	1:2 Splitter
X	L/O	L/O	H	Z	Z	R <sub>IN0+</sub>	R <sub>IN0-</sub>	D <sub>OUT0</sub> Disabled
X	H	L/O	H	Z	Z	R <sub>IN1+</sub>	R <sub>IN1-</sub>	D <sub>OUT0</sub> Disabled
L/O	X	H	L/O	R <sub>IN0+</sub>	R <sub>IN0-</sub>	Z	Z	D <sub>OUT1</sub> Disabled
H	X	H	L/O	R <sub>IN1+</sub>	R <sub>IN1-</sub>	Z	Z	D <sub>OUT1</sub> Disabled
X	X	L/O	L/O	Z	Z	Z	Z	D <sub>OUT0</sub> and D <sub>OUT1</sub> Disabled

O = OPEN L/O = LOW or OPEN H = HIGH Logic Level L = LOW Logic Level X = Don't Care Z = High Impedance

### Function Diagrams



Absolute Maximum Ratings <sup>(Note 1)</sup>		Recommended Operating Conditions	
Supply Voltage ( $V_{CC}$ )	-0.3V to +4.6V	Supply Voltage ( $V_{CC}$ )	3.0V to 3.6V
DC Input Voltage ( $V_{IN}$ )	-0.3V to +4.6V	Input Voltage ( $V_{IN}$ )	0 to $V_{CC}$
DC Output Voltage ( $V_{OUT}$ )	-0.3V to +4.6V	Operating Temperature ( $T_A$ )	-40°C to +85°C
Driver Short Circuit Current ( $I_{OSD}$ )	Continuous	Electrostatic Discharge (HBM 1.5 k $\Omega$ , 100 pF)	>7500V
Storage Temperature Range ( $T_{STG}$ )	-65°C to +150°C	Electrostatic Discharge (MM 0 $\Omega$ , 100 pF)	>300V
Max Junction Temperature ( $T_J$ )	150°C		
Lead Temperature ( $T_L$ ) (Soldering, 10 seconds)	260°C		

**Note 1:** The "Absolute Maximum Ratings": are those values beyond which damage to the device may occur. The databook specifications should be met, without exception, to ensure that the system design is reliable over its power supply, temperature and output/input loading variables. Fairchild does not recommend operation of circuits outside databook specification.

### DC Electrical Characteristics

Over supply voltage and operating temperature ranges, unless otherwise specified (Note 2)

Symbol	Parameter	Test Conditions	Min	Typ (Note 3)	Max	Units
<b>LVDS Differential Driver Characteristics</b>						
$V_{OD}$	Output Differential Voltage	$R_L = 75 \Omega$ , See Figure 3	270	365	475	mV
		$R_L = 75 \Omega$ , See Figure 3 $T_A = 25^\circ\text{C}$ and $V_{CC} = 3.3\text{V}$	285	365	440	
$\Delta V_{OD}$	$V_{OD}$ Magnitude Change from Differential LOW-to-HIGH	$R_L = 75 \Omega$ , See Figure 3			35	mV
$V_{OS}$	Offset Voltage	See Figure 3	1.0	1.2	1.45	V
$\Delta V_{OS}$	Offset Magnitude Change from Differential LOW-to-HIGH	See Figure 3			35	mV
$I_{OZD}$	Disabled Output Leakage Current	$V_{OUT} = 3.6\text{V}$ or GND, Driver Disabled			$\pm 10$	$\mu\text{A}$
$I_{OFF}$	Power-Off Current	$V_{CC} = 0\text{V}$ , $V_{IN}$ or $V_{OUT} = 3.6\text{V}$ or $0\text{V}$			$\pm 20$	$\mu\text{A}$
$I_{OS}$	Short Circuit Output Current	$V_{OUT} = 0\text{V}$ , Driver Enabled			-10	mA
		$V_{OUTx+} = 0\text{V}$ , $V_{OUTx-} = 0\text{V}$ , Driver Enabled			-10	
<b>LVDS Differential Receiver Characteristics</b>						
$V_{TH}$	Differential Input Threshold HIGH	$V_{IC} = 0.05\text{V}$ or $1.2\text{V}$ or $3.25\text{V}$ $V_{CC} = 3.3\text{V}$			100	mV
$V_{TL}$	Differential Input Threshold LOW		-100			
$V_{IC}$	Input Common Mode Voltage		0.05		3.25	V
$I_{IND}$	Input Current (Differential Inputs)	$V_{IN} = \text{GND}$			$\pm 20$	$\mu\text{A}$
		$V_{IN} = V_{CC}$			$\pm 20$	
<b>LVTTL Control Characteristics</b>						
$V_{IH}$	Input High Voltage		2			V
$V_{IL}$	Input Low Voltage				0.8	V
$I_{IN}$	Input Current	$V_{IN} = 3.6\text{V}$ or GND			$\pm 20$	$\mu\text{A}$
<b>Device Characteristics</b>						
$V_{IK}$	Input Clamp Voltage	$I_{IK} = -18\text{mA}$	-1.5			V
$I_{PU/PD}$	Output Power-Up/Power-Down High Z Leakage Current	$V_{CC} = 0\text{V}$ to $1.5\text{V}$			$\pm 10$	$\mu\text{A}$
$C_{IN}$	Input Capacitance			4.5		pF
$C_{OUT}$	Output Capacitance			4.5		pF
$I_{CC}$	Power Supply Current	No Load, All Drivers Enabled			35	mA
		$R_L = 75 \Omega$ , All Drivers Enabled			35	
		$R_L = 75 \Omega$ , All Drivers Enabled			35	

**Note 2:** This part will only function with datasheet specification when a resistive load is applied to the driver outputs.

**Note 3:** All typical values are at  $T_A = 25^\circ\text{C}$  and with  $V_{CC} = 3.3\text{V}$ .

## AC Electrical Characteristics

Over supply voltage and operating temperature ranges, unless otherwise specified

Symbol	Parameter	Test Conditions	Min	Typ (Note 4)	Max	Units
$t_{PLHD}$	Differential Output Propagation Delay LOW-to-HIGH	$R_L = 75 \Omega$ , $C_L = 5 \text{ pF}$ , $V_{CC} = 3.3\text{V}$ , $T_A = 25^\circ\text{C}$ See Figure 4 and Figure 5	0.7		1.6	ns
			1.0	1.2	1.3	
$t_{PHLD}$	Differential Output Propagation Delay HIGH-to-LOW	$R_L = 75 \Omega$ , $C_L = 5 \text{ pF}$ , $V_{CC} = 3.3\text{V}$ , $T_A = 25^\circ\text{C}$ See Figure 4 and Figure 5	0.7		1.6	ns
			1.0	1.2	1.3	
$t_{TLHD}$	Differential Output Rise Time (20% to 80%)	$R_L = 75 \Omega$ , $C_L = 5 \text{ pF}$ , $V_{CC} = 3.3\text{V}$ , $T_A = 25^\circ\text{C}$ See Figure 6 and Figure 7	290		580	ps
$t_{THLD}$	Differential Output Fall Time (80% to 20%)		290		580	ps
$t_{PLH}$	Selection Propagation Delay LOW-to-HIGH ( $SEL_n$ to $OUT_n$ )	$R_L = 75 \Omega$ , $C_L = 5 \text{ pF}$ , $V_{CC} = 3.3\text{V}$ , $T_A = 25^\circ\text{C}$ See Figure 6 and Figure 7	0.6		1.5	ns
			0.9	1.1	1.2	
$t_{PHL}$	Selection Propagation Delay HIGH-to-LOW ( $SEL_n$ to $OUT_n$ )	$R_L = 75 \Omega$ , $C_L = 5 \text{ pF}$ , $V_{CC} = 3.3\text{V}$ , $T_A = 25^\circ\text{C}$ See Figure 6 and Figure 7	0.6		1.5	ns
			0.9	1.1	1.2	
$t_{ZHD}$	Differential Output Enable Time from Z-to-HIGH	$R_L = 75 \Omega$ , $C_L = 5 \text{ pF}$ See Figure 8 and Figure 9			3.5	ns
$t_{ZLD}$	Differential Output Enable Time from Z-to-LOW				3.5	ns
$t_{HZD}$	Differential Output Disable Time from HIGH-to-Z				3.5	ns
$t_{LZD}$	Differential Output Disable Time from LOW-to-Z				3.5	ns
$t_{SET}$	Input ( $IN_{n+}/IN_{n-}$ ) Setup Time to $SEL_n$	See Figure 10	0.5	0.3		ns
$t_{HOLD}$	Input ( $IN_{n+}/IN_{n-}$ ) Hold Time to $SEL_n$	See Figure 10	0.5	0.3		ns
$t_{JIT}$	Output Peak-to-Peak Jitter	$2^{23} - 1$ PRBS Sequence at 800 Mbps			190	ps
		50% Duty Cycle at 800 Mbps		20	35	ps
$f_{TOG}$	Maximum Toggle Frequency	$R_L = 75 \Omega$ , $C_L = 5 \text{ pF}$ , See Figure 4	800	900		Mbps
$t_{SKEW}$	Within Device Channel-to-Channel Skew			35	80	ps
	Pulse Skew ( $t_{PLHD} - t_{PHLD}$ )			0	225	ps
	Part-to-Part Skew (Note 5)			100	500	ps

**Note 4:** All typical values are at  $T_A = 25^\circ\text{C}$  and with  $V_{CC} = 3.3\text{V}$ .

**Note 5:** Part-to-part skew is the maximum delay time difference on like edges (LOW-to-HIGH or HIGH-to-LOW) for the same  $V_{CC}$  and temperature conditions.

## Required Specifications

- When the true and complement LVDS outputs (having a  $75\Omega$  connected between outputs) are connected to  $3.75\text{ k}\Omega$  resistors and the common point of those  $3.75\text{ k}\Omega$  resistors are connected to a voltage source that sweeps from 0 to 2.4V, the DC  $V_{OD}$  and  $\Delta V_{OD}$  are still maintained (see Figure 1).
- When the true and complement LVDS outputs (having a  $5\text{ pF}$  capacitor attached between outputs) are connected with  $37.5\Omega$  resistors each to common point, then the common point does not vary by more than  $150\text{ mV}$  under all process, temperature and voltage conditions when the outputs switch either from LOW-to-HIGH or from HIGH-to-LOW (see Figure 2).
- Pull-down resistors are required on Enable ( $EN_0$  and  $EN_1$ ) and select ( $SEL_0$  and  $SEL_1$ ) inputs.
- Fail safe protection on the outputs that draw less than  $20\text{ }\mu\text{A}$  of current (worst case) on the LVDS inputs. In this condition, if the input is in fail safe selected to  $OUT_{0+}/OUT_{0-}$  (say) and the outputs are Enabled then  $OUT_{0+} = \text{HIGH}$  and  $OUT_{0-} = \text{LOW}$ . This prevents noise from being amplified when the connection is broken.
- In the disabled state the outputs can go beyond  $V_{CC}$  but there should be no appreciable leakage (see  $I_{OZD}$  and  $I_{OFF}$  specifications)

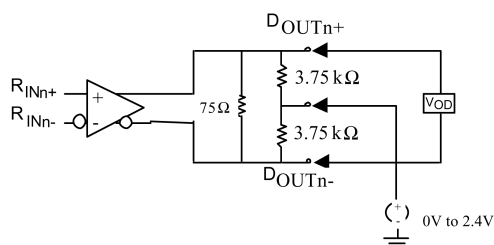


FIGURE 1. Common Mode Supply Test Circuit

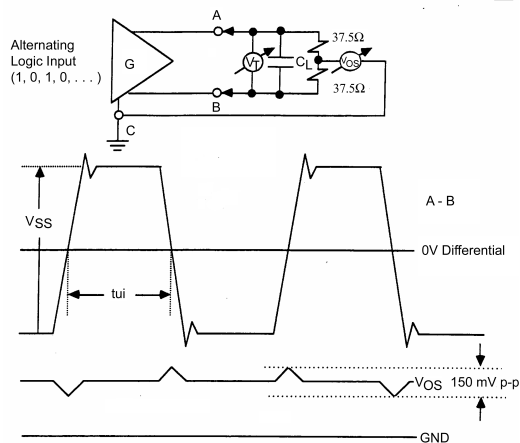
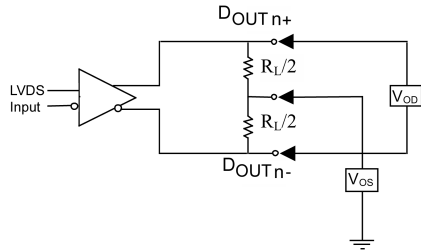
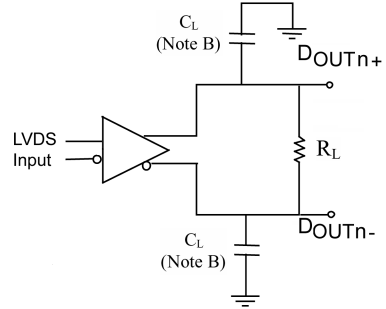


FIGURE 2. Dynamic  $V_{OS}$  Test Circuit and Waveforms

**Required Specifications** (Continued)

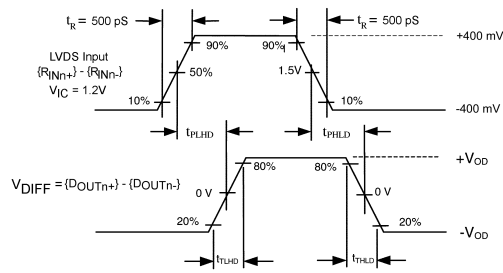


**FIGURE 3. LVDS Driver DC Test Circuit**

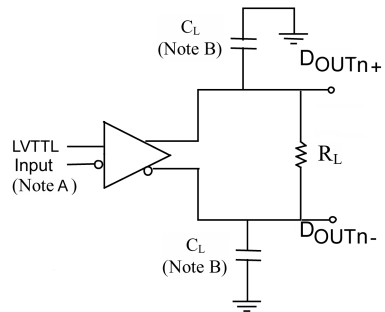


Note A: All input pulses have frequency = 50 MHz,  $t_r$  or  $t_f = 500$  ps  
 Note B:  $C_L$  includes all probe and jig capacitances

**FIGURE 4. LVDS Input to LVDS Driver Propagation Delay and Transition Time Circuit**

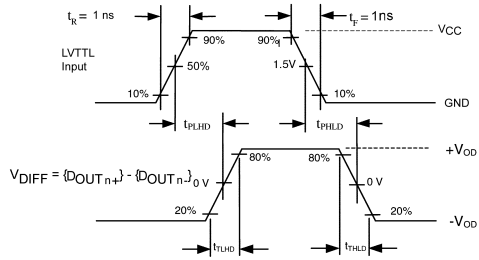


**FIGURE 5. LVDS Input to LVDS Output AC Waveforms**

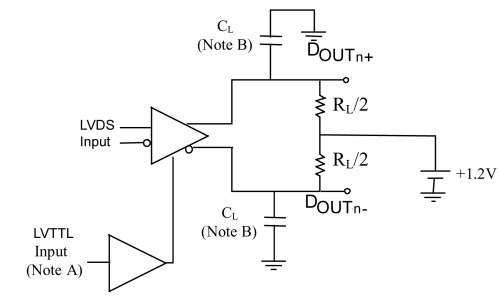


**FIGURE 6. LVTTTL Input to LVDS Driver Propagation Delay and Transition Time Test Circuit**

**Required Specifications** (Continued)

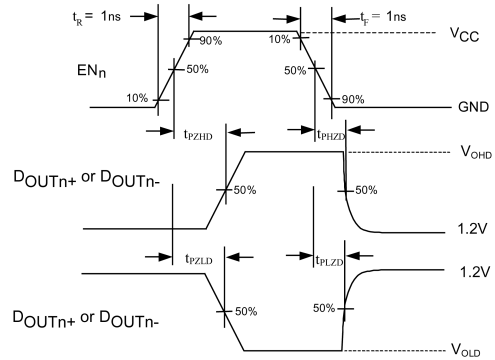


**FIGURE 7. LVTTTL Input to LVDS Output AC Waveforms**



Note A: All input pulses have frequency = 10MHz,  $t_R$  or  $t_F <= 1$  ns.  
 Note B:  $C_L$  includes all probe and jig capacitances.

**FIGURE 8. Differential Driver Enable and Disable Test Circuits**



**FIGURE 9. Enable and Disable AC Waveforms**

Required Specifications (Continued)

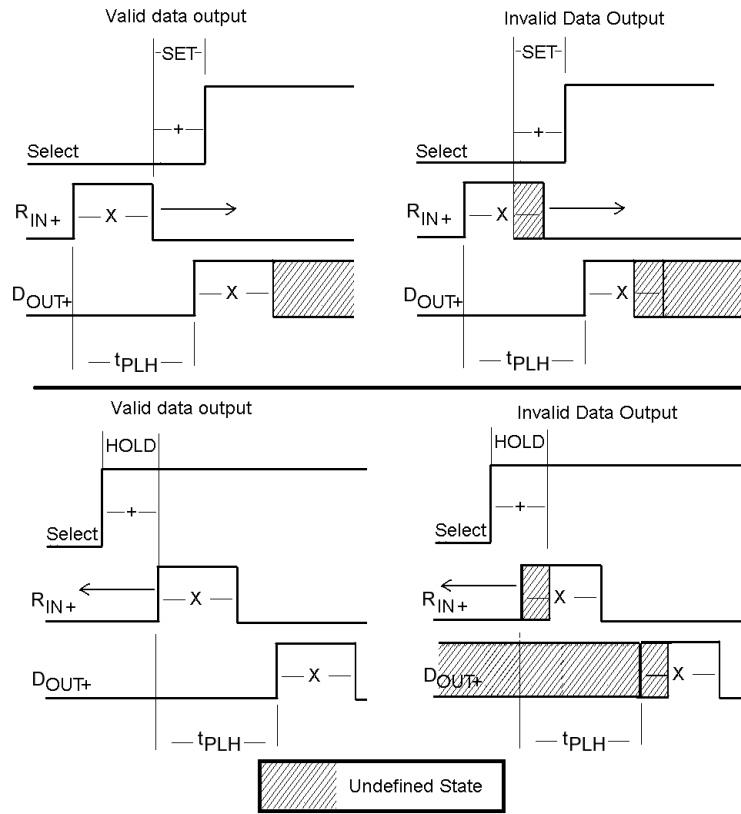
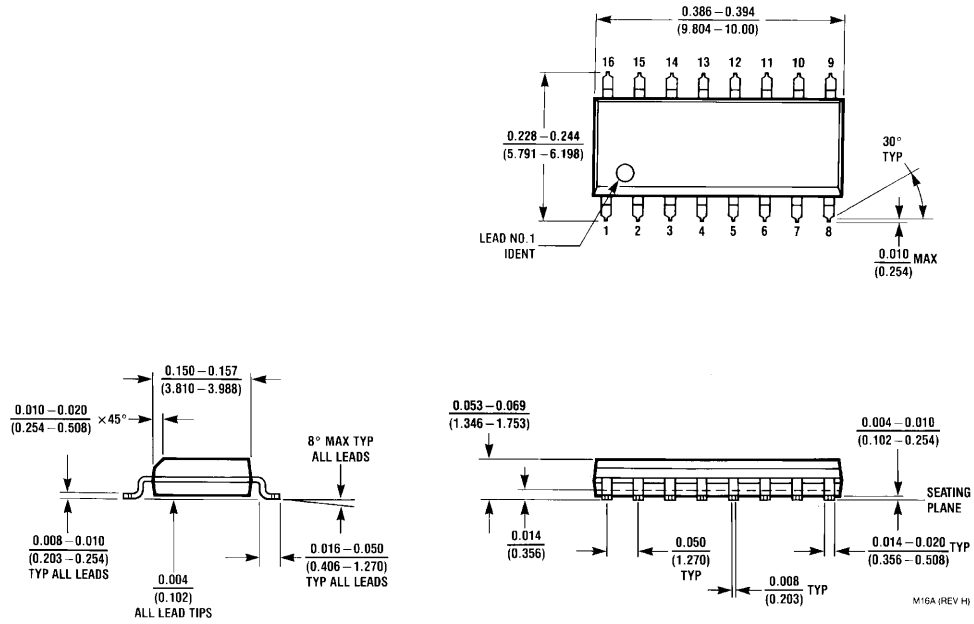


FIGURE 10. Set-up and Hold Time Specification



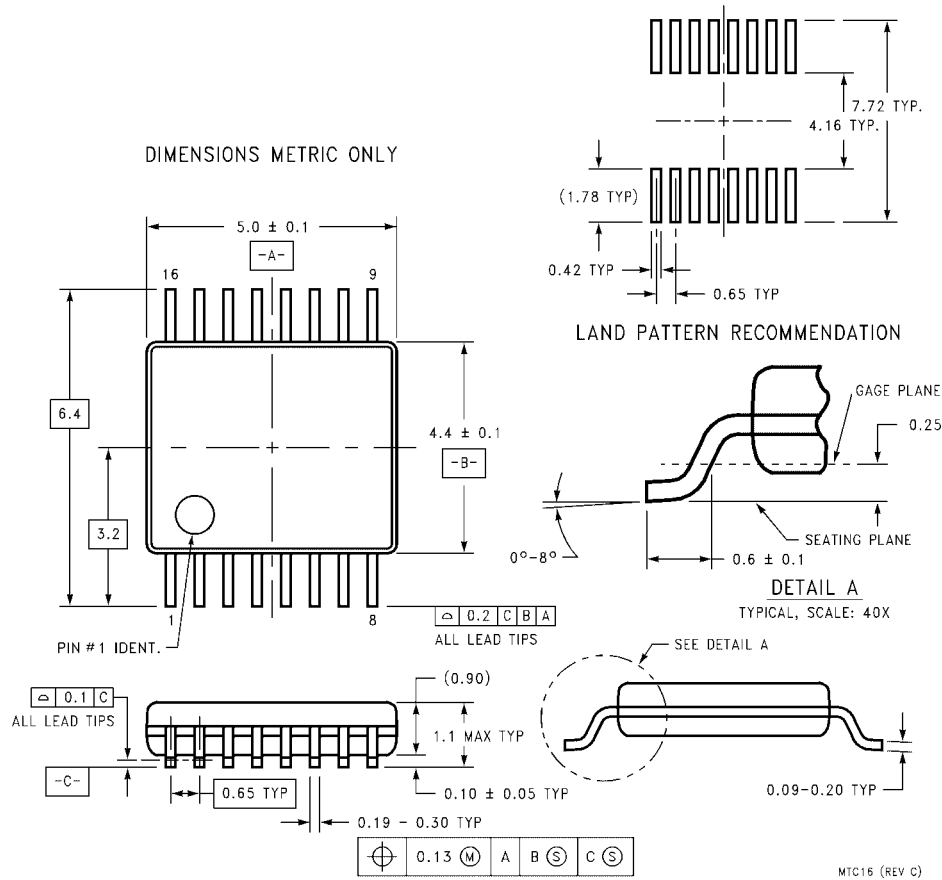
**Physical Dimensions** inches (millimeters) unless otherwise noted



**16-Lead Small Outline Integrated Circuit (SOIC), JEDEC MS-012, 0.150" Narrow  
Package Number M16A**

M16A (REV H)

**Physical Dimensions** inches (millimeters) unless otherwise noted (Continued)



**16-Lead Thin Shrink Small Outline Package (TSSOP), JEDEC MO-153, 4.4mm Wide  
Package Number MTC16**

Fairchild does not assume any responsibility for use of any circuitry described, no circuit patent licenses are implied and Fairchild reserves the right at any time without notice to change said circuitry and specifications.

**LIFE SUPPORT POLICY**

FAIRCHILD'S PRODUCTS ARE NOT AUTHORIZED FOR USE AS CRITICAL COMPONENTS IN LIFE SUPPORT DEVICES OR SYSTEMS WITHOUT THE EXPRESS WRITTEN APPROVAL OF THE PRESIDENT OF FAIRCHILD SEMICONDUCTOR CORPORATION. As used herein:

1. Life support devices or systems are devices or systems which, (a) are intended for surgical implant into the body, or (b) support or sustain life, and (c) whose failure to perform when properly used in accordance with instructions for use provided in the labeling, can be reasonably expected to result in a significant injury to the user.
2. A critical component in any component of a life support device or system whose failure to perform can be reasonably expected to cause the failure of the life support device or system, or to affect its safety or effectiveness.

[www.fairchildsemi.com](http://www.fairchildsemi.com)