

DATA SHEET

SAB6456

SAB6456T

Sensitive 1 GHz

divide-by-64/divide-by-256

switchable prescaler

Product specification
File under Integrated Circuits, IC02

June 1986

Sensitive 1 GHz divide-by-64/divide-by-256 switchable prescaler

SAB6456 SAB6456T

GENERAL DESCRIPTION

The SAB6456/SAB6456T is a prescaler for UHF/VHF tuners. It can be switched to divide-by-64 or divide-by-256 by the mode-control (MC) pin. The circuit has an input frequency range of 70 MHz to 1 GHz, has high input sensitivity and good harmonic suppression.

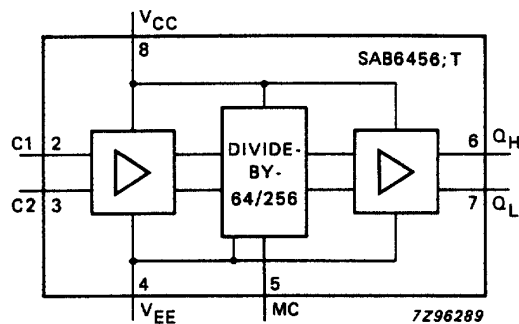

Fig.1 Block diagram.

QUICK REFERENCE DATA

PARAMETER	CONDITIONS	SYMBOL	MIN.	TYP.	MAX.	UNIT
Supply voltage	pin 8 to pin 4	V_{CC}	4,5	5,0	5,5	V
Supply current	pin 8	I_{CC}	–	21	–	mA
Input frequency range	pins 2 and 3	f_i	70	–	1000	MHz
Sensitivity to input voltage (r.m.s. value)		$V_{i(rms)}$	–	–	10	mV
Output voltage (peak-to-peak value)	pins 6 and 7	$V_{o(p-p)}$	–	1	–	V
Operating ambient temperature range		T_{amb}	0	–	80	°C

PACKAGE OUTLINES

SAB6456 : 8-lead DIL; plastic (SOT97); SOT97-1; 1996 November 18.

SAB6456T: 8-lead mini-pack (SO8; SOT96A); SOT96-1; 1996 November 18.

Sensitive 1 GHz divide-by-64/divide-by-256 switchable prescaler

SAB6456 SAB6456T

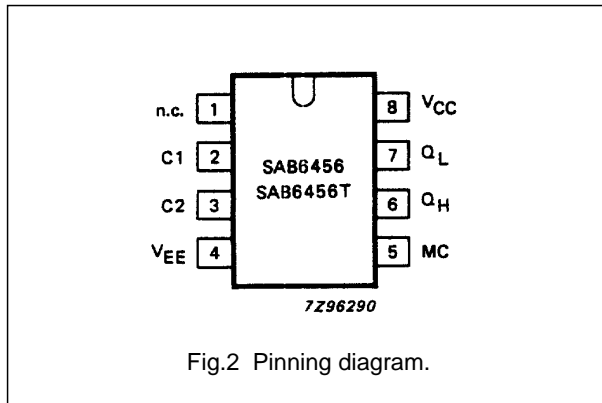

PINNING

1.	n.c.	not connected
2.	C1	differential inputs
3.	C2	
4.	V _{EE}	ground (0 V)
5.	MC	mode control
6.	Q _H	complementary outputs
7.	Q _L	
8.	V _{CC}	positive supply voltage

FUNCTIONAL DESCRIPTION

The circuit comprises an input amplifier, a divider stage with selectable division ratio and an output stage.

The input amplifier is driven by a sinusoidal signal from the local oscillator of a television tuner. The inputs (C1, C2) are differential and are biased internally to permit capacitive coupling. When driven asymmetrically the unused input should be connected to ground via a capacitor.

The mode-control (MC) input to the divider stage is intended for static control of the division ratio, selection is made as follows:

divide-by-64: MC pin open-circuit

divide-by-256: MC pin connected to ground

The divider stage may oscillate during no-signal conditions but this oscillation is suppressed when input signals are received.

Two complementary signals (Q_H, Q_L) are provided by the output differential amplifier stage. The voltage-edges of the output signals are slowed internally to reduce harmonics in the television intermediate frequency band.

Sensitive 1 GHz divide-by-64/divide-by-256 switchable prescaler

SAB6456 SAB6456T

ELECTROSTATIC DISCHARGE PROTECTION

Inputs and outputs have electrostatic discharge protection according to specification MIL-883C, class B.

RATINGS

Limiting values in accordance with the Absolute Maximum System (IEC-134)

PARAMETER	CONDITIONS	SYMBOL	MIN.	TYP.	MAX.	UNIT
Supply voltage	pin 8 to pin 4	V_{CC}	–	–	7,0	V
Input voltage		V_i	–	–	V_{CC}	V
Storage temperature range		T_{stg}	–55	–	+ 150	°C
Junction temperature		T_j	–	–	+ 150	°C

THERMAL RESISTANCE

From junction to ambient

8-lead DIL; plastic (SOT-97A)

$R_{th\ j-a}$ 120 K/W

8-lead mini-pack (SO-8; SOT-96A)

on printed circuit board

$R_{th\ j-a}$ 260 K/W

on ceramic substrate

$R_{th\ j-a}$ 170 K/W

D.C. CHARACTERISTICS

$V_{CC} = 5\text{ V}$; $V_{EE} = 0\text{ V}$; $T_{amb} = 25\text{ °C}$; test IC mounted in a test socket or on a printed circuit board; measurements taken after thermal equilibrium is established

PARAMETER	CONDITIONS	SYMBOL	MIN.	TYP.	MAX.	UNIT
Output voltage HIGH		V_{OH}	–	–	V_{CC}	V
Output voltage LOW		V_{OL}	–	–	$V_{CC} - 0.8$	V
Supply current		I_{CC}	–	21	28	mA
Mode-control (MC)						
Input voltage LOW (divide-by-256)		V_{iL}	0	–	0,2	V
Input current LOW		$-I_L$	–	25	60	μA
Input voltage HIGH (divide-by-64)	pin 5 open-circuit	V_{iH}	1,4	–	3,0	V

Sensitive 1 GHz divide-by-64/divide-by-256 switchable prescaler

SAB6456 SAB6456T

A.C. CHARACTERISTICS

$V_{CC} = 4,5$ to $5,5$ V; $V_{EE} = 0$ V; $T_{amb} = 0$ to $+80$ °C

PARAMETER	CONDITIONS	SYMBOL	MIN.	TYP.	MAX.	UNIT
Sensitivity to input voltage (r.m.s. value)	50 Ω system					
	$f_i = 70$ MHz	$V_{i(rms)}$	–	–	10	mV
	$f_i = 150$ MHz	$V_{i(rms)}$	–	–	10	mV
	$f_i = 300$ MHz	$V_{i(rms)}$	–	–	10	mV
	$f_i = 500$ MHz	$V_{i(rms)}$	–	–	10	mV
	$f_i = 900$ MHz	$V_{i(rms)}$	–	–	10	mV
	$f_i = 1000$ MHz	$V_{i(rms)}$	–	–	10	mV
Input overload voltage (r.m.s. value)	50 Ω system					
	$f_i = 70$ MHz to 1000 MHz	V_i	300	–	–	mV
Input parallel resistance	$f_i = 70$ MHz	R_i	–	560	–	Ω
	$f_i = 1000$ MHz	R_i	–	30	–	Ω
Input capacitance	$f_i = 70$ MHz	C_i	–	5	–	pF
	$f_i = 1000$ MHz	C_i	–	1,5	–	pF
Output voltage HIGH		V_{OH}	–	–	V_{CC}	V
Output voltage LOW		V_{OL}	–	–	$V_{CC} - 0,8$	V
Output voltage swing (peak-to-peak value)	$f_i = 70$ MHz	$V_{o(p-p)}$	0,8	1,0	1,2	V
	$f_i = 1000$ MHz; $R_L = 820 \Omega$; $C_L = 60$ pF	$V_{o(p-p)}$	0,17	–	–	V
Attenuation of third harmonic at output	$f_i = 800$ MHz; $R_L = 820 \Omega$; $C_L = 60$ pF		–15	–23	–	dB
Output unbalance	see Fig.3	ΔV_o	–	–	0,1	V
Output resistance		R_o	–	500	–	Ω

Sensitive 1 GHz divide-by-64/divide-by-256
switchable prescaler

SAB6456
SAB6456T

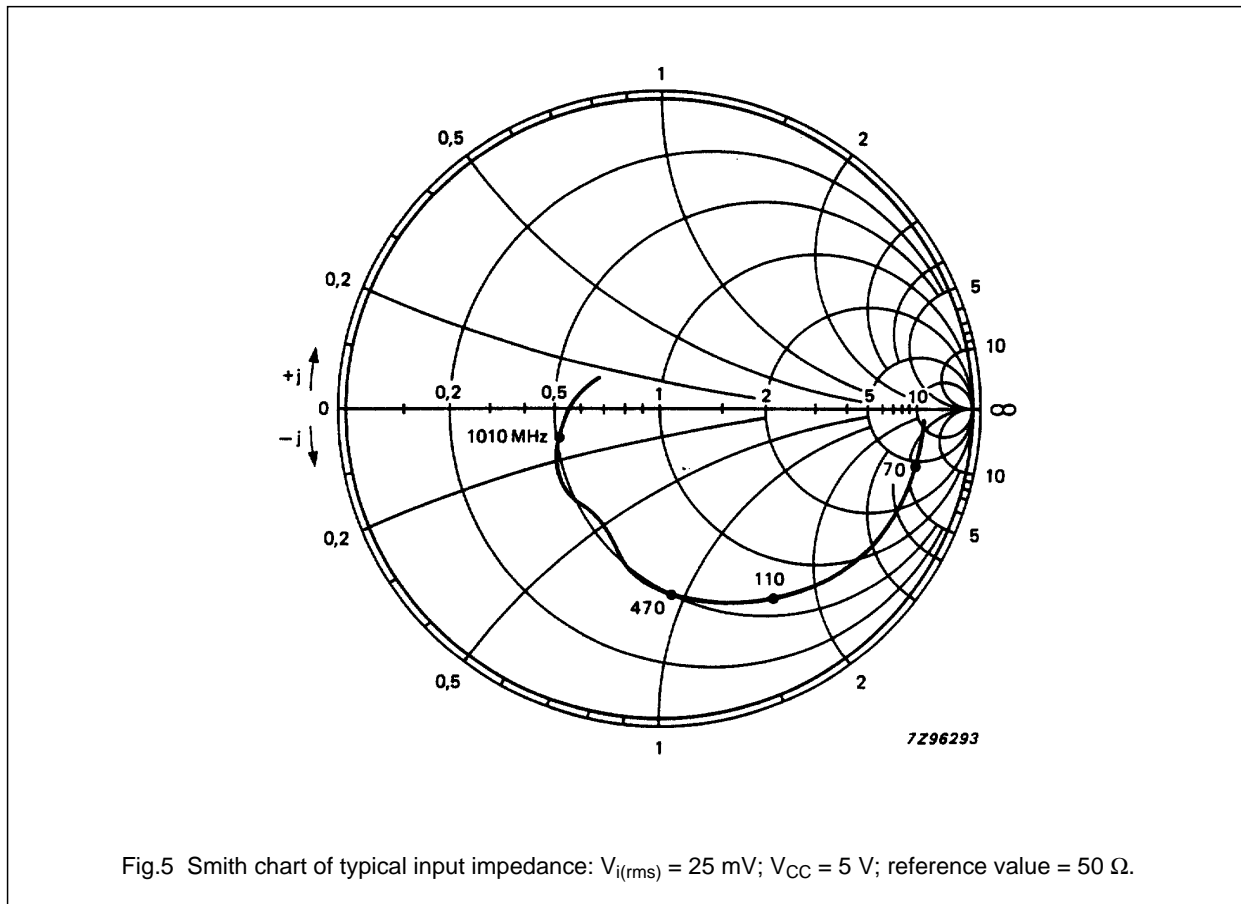
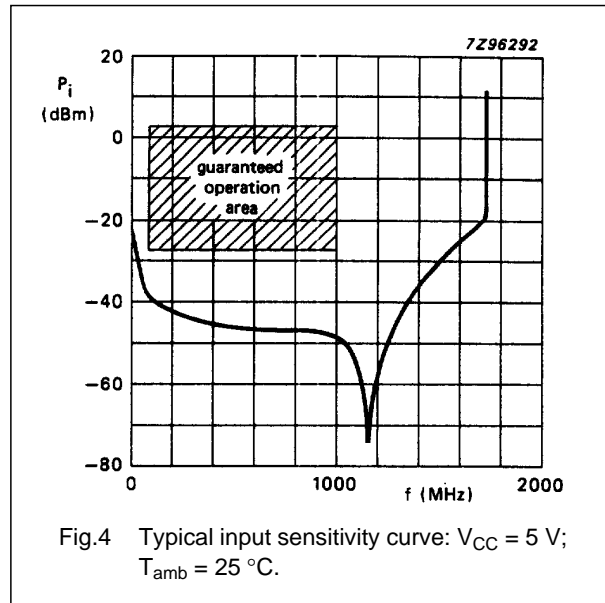
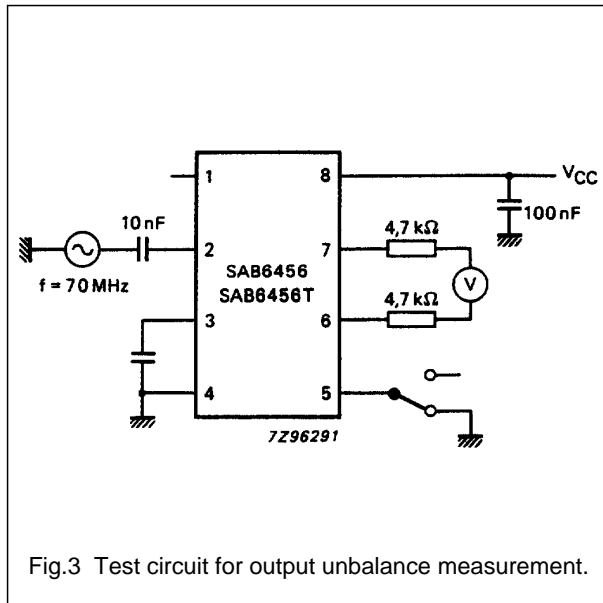

Sensitive 1 GHz divide-by-64/divide-by-256
switchable prescaler

SAB6456
SAB6456T

PACKAGE OUTLINES

DIP8: plastic dual in-line package; 8 leads (300 mil)

SOT97-1

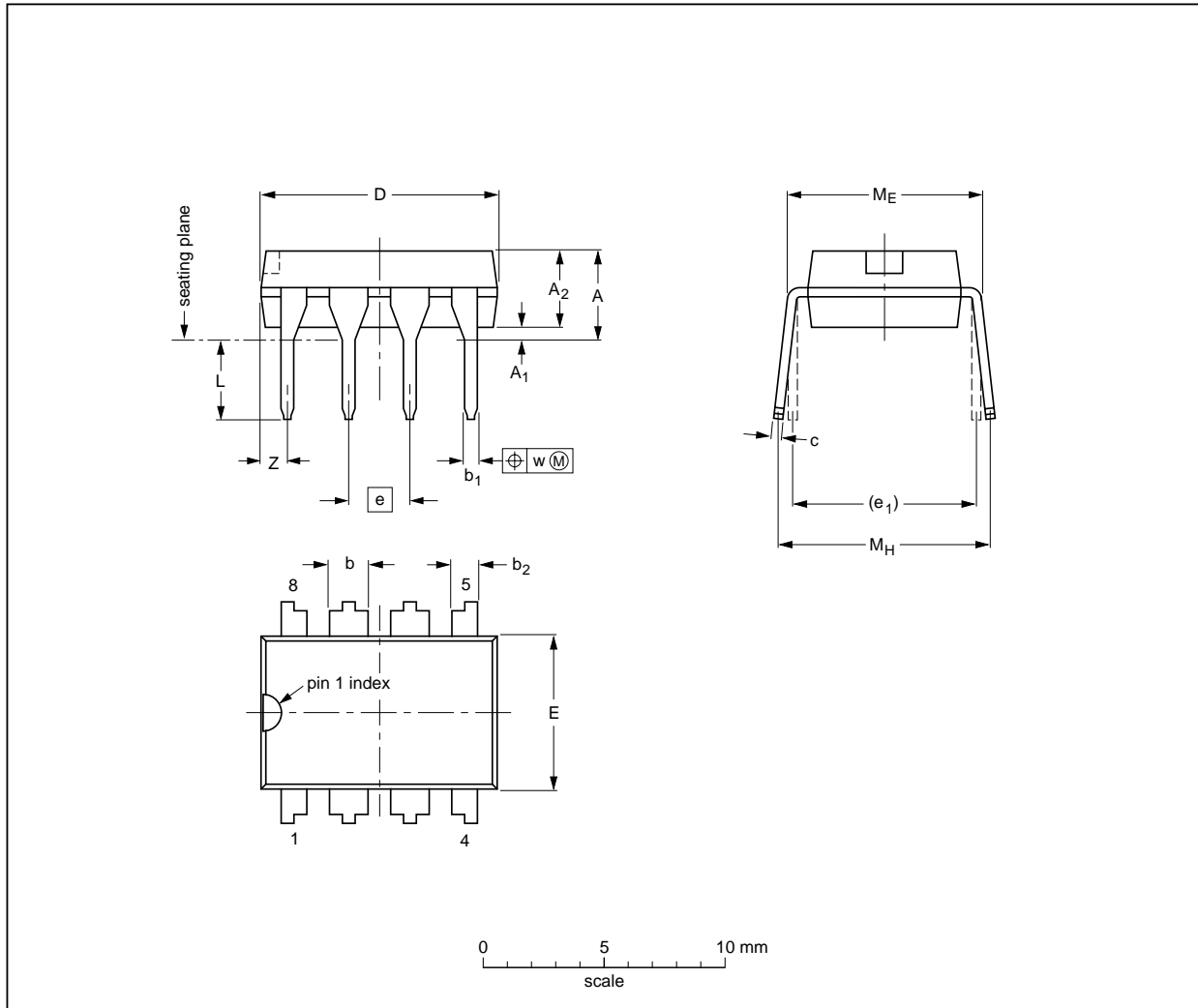

DIMENSIONS (inch dimensions are derived from the original mm dimensions)

UNIT	A max.	A ₁ min.	A ₂ max.	b	b ₁	b ₂	c	D ⁽¹⁾	E ⁽¹⁾	e	e ₁	L	M _E	M _H	w	Z ⁽¹⁾ max.
mm	4.2	0.51	3.2	1.73 1.14	0.53 0.38	1.07 0.89	0.36 0.23	9.8 9.2	6.48 6.20	2.54	7.62	3.60 3.05	8.25 7.80	10.0 8.3	0.254	1.15
inches	0.17	0.020	0.13	0.068 0.045	0.021 0.015	0.042 0.035	0.014 0.009	0.39 0.36	0.26 0.24	0.10	0.30	0.14 0.12	0.32 0.31	0.39 0.33	0.01	0.045

Note

1. Plastic or metal protrusions of 0.25 mm maximum per side are not included.

OUTLINE VERSION	REFERENCES				EUROPEAN PROJECTION	ISSUE DATE
	IEC	JEDEC	EIAJ			
SOT97-1	050G01	MO-001AN				92-11-17 95-02-04

Sensitive 1 GHz divide-by-64/divide-by-256
switchable prescaler

SAB6456
SAB6456T

SO8: plastic small outline package; 8 leads; body width 3.9 mm

SOT96-1

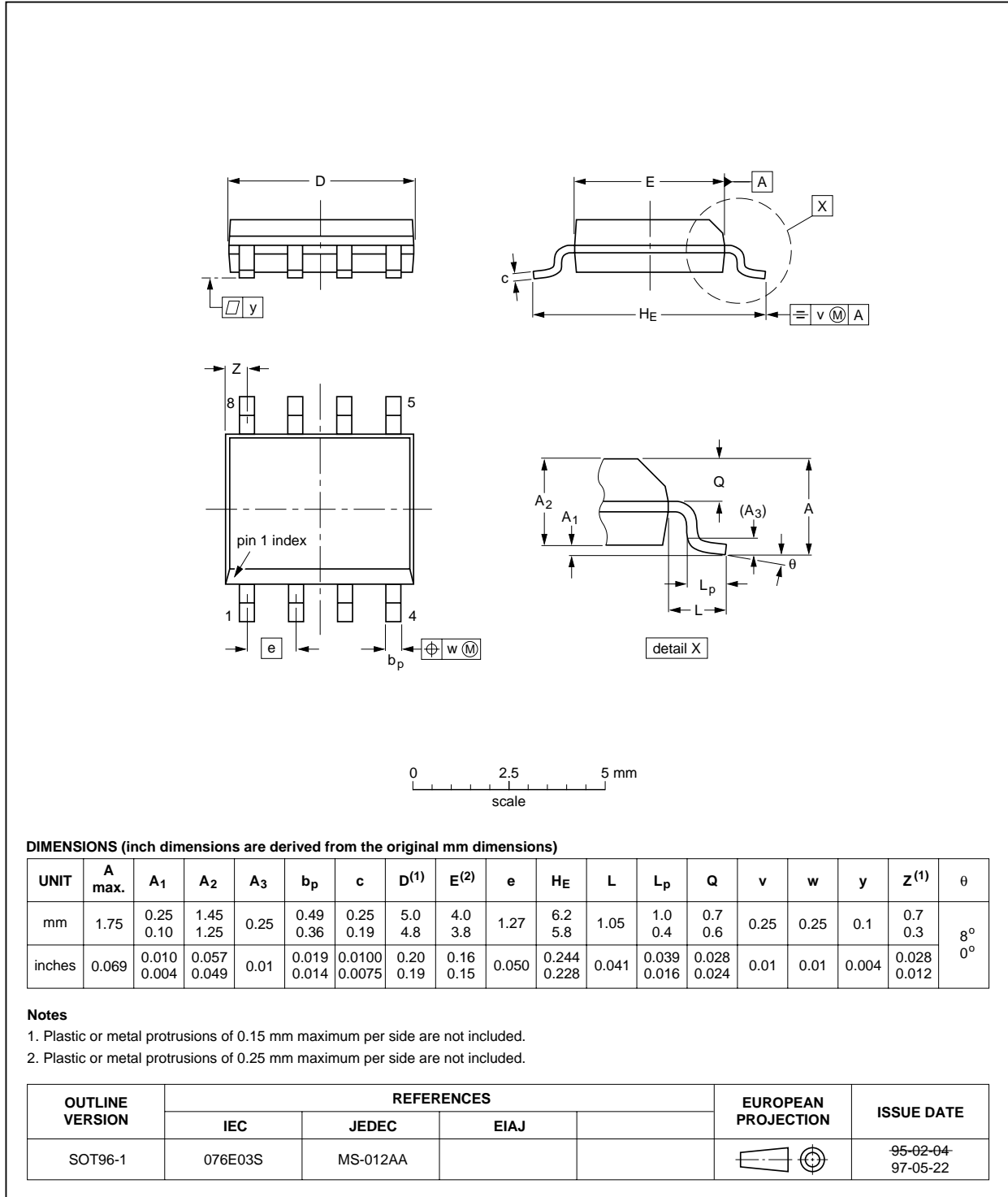

Sensitive 1 GHz divide-by-64/divide-by-256 switchable prescaler

SAB6456
SAB6456T

SOLDERING

Introduction

There is no soldering method that is ideal for all IC packages. Wave soldering is often preferred when through-hole and surface mounted components are mixed on one printed-circuit board. However, wave soldering is not always suitable for surface mounted ICs, or for printed-circuits with high population densities. In these situations reflow soldering is often used.

This text gives a very brief insight to a complex technology. A more in-depth account of soldering ICs can be found in our *"IC Package Databook"* (order code 9398 652 90011).

DIP

SOLDERING BY DIPPING OR BY WAVE

The maximum permissible temperature of the solder is 260 °C; solder at this temperature must not be in contact with the joint for more than 5 seconds. The total contact time of successive solder waves must not exceed 5 seconds.

The device may be mounted up to the seating plane, but the temperature of the plastic body must not exceed the specified maximum storage temperature ($T_{stg\ max}$). If the printed-circuit board has been pre-heated, forced cooling may be necessary immediately after soldering to keep the temperature within the permissible limit.

REPAIRING SOLDERED JOINTS

Apply a low voltage soldering iron (less than 24 V) to the lead(s) of the package, below the seating plane or not more than 2 mm above it. If the temperature of the soldering iron bit is less than 300 °C it may remain in contact for up to 10 seconds. If the bit temperature is between 300 and 400 °C, contact may be up to 5 seconds.

SO

REFLOW SOLDERING

Reflow soldering techniques are suitable for all SO packages.

Reflow soldering requires solder paste (a suspension of fine solder particles, flux and binding agent) to be applied to the printed-circuit board by screen printing, stencilling or pressure-syringe dispensing before package placement.

Several techniques exist for reflowing; for example, thermal conduction by heated belt. Dwell times vary between 50 and 300 seconds depending on heating method. Typical reflow temperatures range from 215 to 250 °C.

Preheating is necessary to dry the paste and evaporate the binding agent. Preheating duration: 45 minutes at 45 °C.

WAVE SOLDERING

Wave soldering techniques can be used for all SO packages if the following conditions are observed:

- A double-wave (a turbulent wave with high upward pressure followed by a smooth laminar wave) soldering technique should be used.
- The longitudinal axis of the package footprint must be parallel to the solder flow.
- The package footprint must incorporate solder thieves at the downstream end.

During placement and before soldering, the package must be fixed with a droplet of adhesive. The adhesive can be applied by screen printing, pin transfer or syringe dispensing. The package can be soldered after the adhesive is cured.

Maximum permissible solder temperature is 260 °C, and maximum duration of package immersion in solder is 10 seconds, if cooled to less than 150 °C within 6 seconds. Typical dwell time is 4 seconds at 250 °C.

A mildly-activated flux will eliminate the need for removal of corrosive residues in most applications.

REPAIRING SOLDERED JOINTS

Fix the component by first soldering two diagonally-opposite end leads. Use only a low voltage soldering iron (less than 24 V) applied to the flat part of the lead. Contact time must be limited to 10 seconds at up to 300 °C. When using a dedicated tool, all other leads can be soldered in one operation within 2 to 5 seconds between 270 and 320 °C.

**Sensitive 1 GHz divide-by-64/divide-by-256
switchable prescaler**

**SAB6456
SAB6456T**

DEFINITIONS

Data sheet status	
Objective specification	This data sheet contains target or goal specifications for product development.
Preliminary specification	This data sheet contains preliminary data; supplementary data may be published later.
Product specification	This data sheet contains final product specifications.
Limiting values	
Limiting values given are in accordance with the Absolute Maximum Rating System (IEC 134). Stress above one or more of the limiting values may cause permanent damage to the device. These are stress ratings only and operation of the device at these or at any other conditions above those given in the Characteristics sections of the specification is not implied. Exposure to limiting values for extended periods may affect device reliability.	
Application information	
Where application information is given, it is advisory and does not form part of the specification.	

LIFE SUPPORT APPLICATIONS

These products are not designed for use in life support appliances, devices, or systems where malfunction of these products can reasonably be expected to result in personal injury. Philips customers using or selling these products for use in such applications do so at their own risk and agree to fully indemnify Philips for any damages resulting from such improper use or sale.