

DESCRIPTION

The M66510 is a semiconductor laser diode driver that drives a semiconductor laser of the type whose cathode and the anode of monitor photodiode are connected to the stem. Laser driving current of up to 120mA can be set by applying constant voltage from outside to drive the laser diode. It operates from a 5V single power supply, allowing switching of laser driving current at a speed of 20M bits/sec.

*: Our semiconductor laser is of R type.

FEATURES

- Built-in two outputs for monitoring laser power (comparator output and analog output)
- With laser driving current forced off pin
- High-speed switching (20M bits/s)
- High driving current (120mA max.)
- 5V single power supply

APPLICATION

Laser beam printer

PIN CONFIGURATION (TOP VIEW)

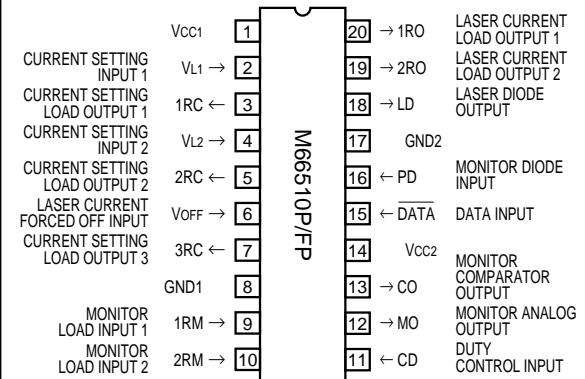

Outline 20P4K

BLOCK DIAGRAM

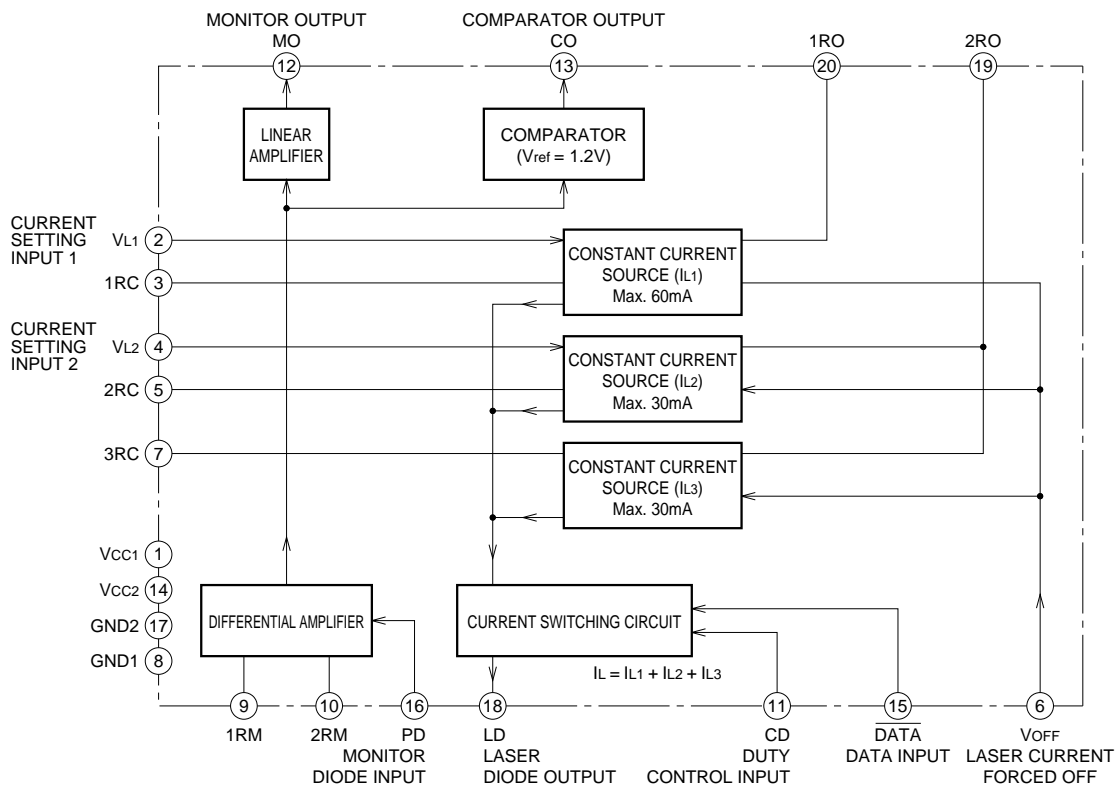

VL1, 1RC: LASER CURRENT (IL1) SETTING PIN
 VL2, 2RC: LASER CURRENT (IL2) SETTING PIN
 3RC: LASER CURRENT (IL3) SETTING PIN
 Vcc1, GND1: IC INTERNAL ANALOG POWER SUPPLY PIN
 Vcc2, GND2: IC INTERNAL DIGITAL POWER SUPPLY PIN

FUNCTION

The 66510 is a semiconductor laser diode driver that drives a semiconductor laser of the type (our R type) whose cathode and the anode of monitor photodiode are connected to the stem. Using the R type laser allows direct fixing the laser on a device for easy installation, thus improving its radiation efficiency.

Laser driving current is set by applying voltage from outside. The M66510 is equipped with two independent voltage applying pins to provide higher accuracy of setting the current value.

It is also equipped with a laser current forced off pin to prevent overcurrent from flowing into the laser diode at the power-ON time.

For detection of laser power, the monitor current of monitor photodiode built in the laser is converted into voltage by an external resistor to generate an analog output, and simultaneously the result of comparison with the internal reference voltage is output as TTL-level logic information.

PIN DESCRIPTIONS

Pin name	Name	Function
LD	Laser connecting pin	Connects the anode of semiconductor laser diode.
PD	Monitor diode connecting pin	Connects the cathode of monitor photodiode.
VL1	Voltage input pin for IL1 setting	Voltage input for setting the output current (IL1) of current source 1.
1RC	Load resistor connecting pin for IL1 setting	Connects IL1 setting load resistor between the pin and GND.
VL2	Voltage input pin for IL2 setting	Voltage input for setting the output current (IL2) of current source 2.
2RC	Load resistor connecting pin for IL2 setting	Connects IL2 setting load resistor between the pin and GND.
3RC	Load resistor connecting pin for IL3 setting	Connects IL3 setting load resistor between the pin and GND. If IL3 is not used, open the pin.
DATA	Switching data input pin	Turns on the laser in the "L" position, and off in the "H" position.
1RM, 2RM	Monitor load resistor connecting pin	Connects between 1RM and 2RM the load resistor for converting monitor photodiode current into voltage.
MO	Monitor analog output pin	Analog output for monitoring laser power.
CO	Monitor comparator output pin	Comparator output for monitoring laser power.
VOFF	Laser current forced off input pin	Turns off all current source circuits in the "L" position.
1RO	Load resistor connecting pin for laser current IL1	Connects load resistor for laser current IL1 between 1RO pin and Vcc.
2RO	Load resistor connecting pin for laser current IL2/IL3	Connects load resistor for laser current IL2 and IL3 between 2RO pin and Vcc.
Cd	Duty compensating capacitor connecting pin	Connects duty compensating capacitor of optical output switch waveforms between the pin and GND. If duty compensation is not required, open the pin.
VCC1	Power supply pin 1	Power supply for internal analog circuits. Connected to positive power supply (+5V).
VCC2	Power supply pin 2	Power supply for internal digital circuits. Connected to positive power supply (+5V).
GND1	GND pin 1	GND for internal analog circuits.
GND2	GND pin 2	GND for internal digital circuits.

DESCRIPTION OF OPERATION

1. Setting laser driving current

The M66510 is provided internally with three constant current sources IL1, IL2 and IL3, allowing setting of each independent output current.

The methods of setting IL1 to IL3 are given below in (1) to (3).

(1) Method of setting IL1

IL1 is approximated by the VL1 pin input voltage and the resistor (RC1) connected between 1RC pin and GND as follows:

$$IL1[mA] = 12 \times \frac{VL1[V]}{RC1[k\Omega]}$$

However, $0 \leq VL1 \leq VCC - 1.8V$, $IL1(max.) = 60mA$

(2) Method of setting IL2

IL2 is approximated by the VL2 pin input voltage and the resistor (RC2) connected between 2RC pin and GND as follows:

$$IL2[mA] = 6 \times \frac{VL2[V]}{RC2[k\Omega]}$$

However, $0 \leq VL2 \leq VCC - 1.8V$, $IL2(max.) = 30mA$

(3) Method of setting IL3

IL3 is approximated by the internal reference voltage (Vref) and the resistor (RC3) connected between 3RC pin and GND as follows:

$$IL3[mA] = 10 \times \frac{Vref[V]}{RC3[k\Omega]}$$

However, $Vref = 1.2V$ (standard), $IL3(max.) = 30mA$

Note: The expressions for setting IL1 to IL3 are typical. Actually, the set values fluctuate several % depending on IC lot dispersion or operating ambient temperature (See the ELECTRICAL CHARACTERISTICS).

2. Switching operation

The laser is turned on when $\overline{DATA} = "L"$. At this time, the laser driving current is $IL1 + IL2 + IL3$.

The laser is turned off when $\overline{DATA} = "H"$. At this time, the laser driving current becomes almost 0 regardless of IL1 to IL3.

3. Usage of VOFF input

The current which flows into the laser becomes 0 when $\overline{DATA} = "H"$. And the laser is turned off but the internal current sources are active.

Contrarily, the internal current sources are turned off when $VOFF = "L"$. It is therefore possible to prevent overcurrent from flowing into the laser by setting VOFF input to "L" until VCC reaches 3.5V (standard) at the power-ON time, for example (See 6. Internal reset).

4. Laser power monitor operation

The M66510 outputs the information on monitor photodiode (PD) built in the laser from the MO and CO pins in the flow given below.

(1) The current equal to the PD current produced through emission of the laser flows into the resistor (RM) connected between 1RM and 2RM. The potential difference (VM) produced on RM is converted into a level from GND by the internal differential amplifier.

(2) The VM is output as an analog output from the MO pin through the buffer amplifier and compared to the internal reference voltage Vref (1.2V standard) by the comparator. Then the result of comparison is output from the CO pin on the TTL level.

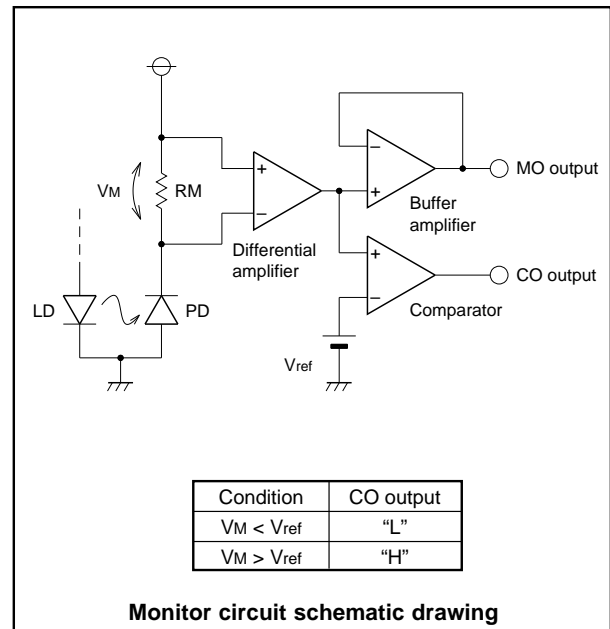

5. 1RO/2RO pin

The 1RO pin is used to connect the load resistor (RO1) for current source 1 (IL1). The 2RO pin is used to connect the load resistor (RO2) for current sources 2 (IL2) and 3 (IL3). Connecting the load resistor between each pin and Vcc reduces IC internal power dissipation.

Set a resistance value so that each pin voltage does not go down to 3.5V or less. In other words, set a value such as meets the following expression:

$$RO1(RO2)[\Omega] \leq$$

$$\frac{V_{CC} - 3.5[V]}{\text{Maximum load current [A] flowing into RO1(RO2)}}$$

Ex: When Vcc = 5V and maximum load current of each source is 60mA, RO1 and RO2 will be 25Ω or less.

6. Internal reset operation

The M66510 is provided with an internal reset circuit to prevent overcurrent from flowing into the laser at the power-ON time. The reset circuit operates within the range of Vcc < 3.5V (standard) to turn off all the current sources.

7. Vcc/GND pin

The power supply pins include Vcc1, Vcc2, GND1 and GND2, each of which is as follows in terms of internal circuit:

Vcc1/GND1: Connected to an analog circuit.

Vcc2/GND2: Connected to a digital circuit.

In actual wiring, pay attention to the following:

- (1) Make wiring width as wide as possible. Avoid redundant wiring.
- (2) Lay out an electrolytic capacitor for stabilizing voltage as close to Vcc1/GND1 as possible.
- (3) Lay out a bypass capacitor as close to Vcc2/GND2 as possible.

Precaution for peripheral element wiring

Lay out the peripheral elements required for M66510 operation as close to M66510 as possible.

Method of calculating power dissipation

The power dissipation P of M66510 is given by the expression given below.

$$P = I_{CC} \times V_{CC} + I_{(1RO)} \times (V_{(1RO)} - V_{(LD)}) + I_{(2RO)} \times (V_{(2RO)} - V_{(LD)}) + I_{OL(CO)} \times V_{OL(CO)}$$

where, V(1RO) : 1RO pin voltage

V(2RO) : 2RO pin voltage

I(1RO) : 1RO pin load current

I(2RO) : 2RO pin load current

V(LD) : LD pin voltage

IOL(CO) : CO pin "L" output current

VOL(CO) : CO pin "L" output voltage

For example, when Vcc = 5.25V, V(1RO) = V(2RO) = 3.5V, I(1RO) = I(2RO) = 60mA, V(LD) = 2.5V, IOL(CO) = 8mA and VOL(CO) = 0.5V, the power dissipation at the laser-ON/OFF time is as follows:

(1) Laser-ON time ($\overline{\text{DATA}} = \text{"L"} , I_{CC} = 26\text{mA}$)

$$P_{ON} = 26 \times 5.25 + 60 \times (3.5 - 2.5) + 60 \times (3.5 - 2.5) + 8 \times 0.5 = 260.5(\text{mW})$$

(2) Laser-OFF time ($\overline{\text{DATA}} = \text{"H"} , I_{CC} = 44\text{mA}$)

$$P_{OFF} = 44 \times 5.25 + 0 + 0 + 8 \times 0.5 = 235(\text{mW})$$

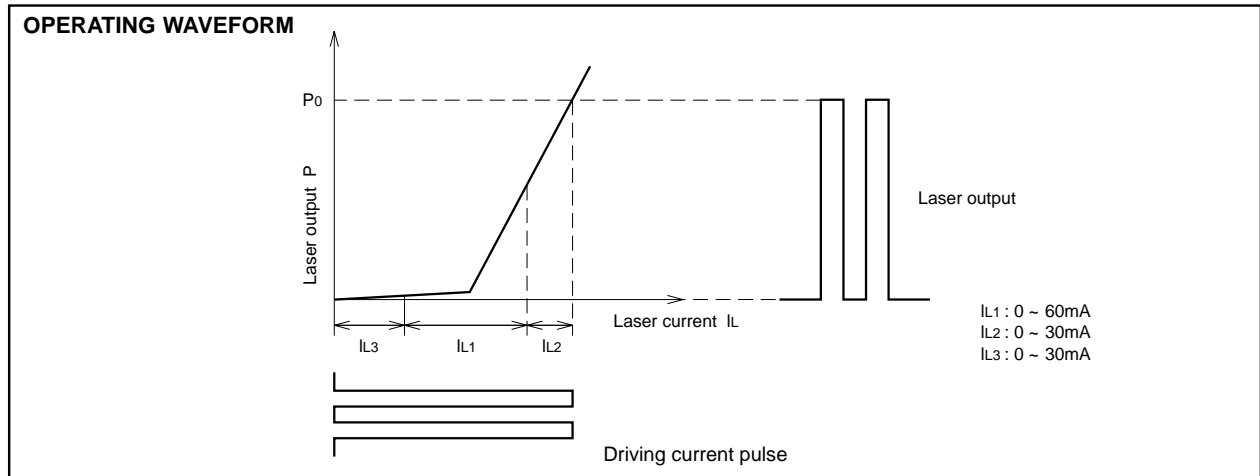

ABSOLUTE MAXIMUM RATINGS

Symbol	Parameter	Conditions	Ratings	Unit
VCC	Supply voltage		-0.5 ~ +7.0	V
Vi	Input voltage	VL1, VL2	-0.3 ~ VCC	V
		DATA, VOFF	-0.3 ~ +7	
Vo	Output current	CO	When output is "H"	V
		1RO, 2RO	-0.3 ~ +7	
IL1	Output current 1		-90	mA
IL2	Output current 2		-45	mA
IL3	Output current 3		-45	mA
Pd	Power dissipation	DIP	IC unit, when Ta=25°C (Note 1)	mW
		SOP	IC unit, when Ta=25°C (Note 2)	
Tstg	Storage temperature		-65 ~ 150	°C

Note 1: When Ta ≥ 25°C, do derating of 10.4mW/°C.
 Note 2: When Ta ≥ 25°C, do derating of 6.4mW/°C.

RECOMMENDED OPERATING CONDITIONS

Symbol	Parameter	Conditions	Limits			Unit
			Min.	Typ.	Max.	
VCC	Supply voltage		4.75	5	5.25	V
IL1	Output current 1				-60	mA
IL2	Output current 2				-30	mA
IL3	Output current 3				-30	mA
Topr	Operating ambient temperature		-20		75	°C

ELECTRICAL CHARACTERISTICS (VCC = 5V ± 5%, Ta = -20 ~ 75°C, unless otherwise noted)

Symbol	Parameter	Test conditions	Limits			Unit	
			Min.	Typ.*	Max.		
V _{IH}	"H" input voltage	$\overline{\text{DATA}}$, V _{OFF}	2			V	
V _{IL}	"L" input voltage	$\overline{\text{DATA}}$, V _{OFF}			0.8	V	
V _I	Upper limit of effective input voltage	V _{L1} , V _{L2}	V _{CC} -1.8	V _{CC} -1.4		V	
V _{OH}	"H" output voltage	CO	I _{OH} =-400μA	2.7		V	
V _{OL}	"L" output voltage	CO	I _{OL} =4mA		0.4	V	
			I _{OL} =8mA		0.5		
V _{LD}	Operating supply voltage	LD		0	2.5	V	
V _{OS}	Output offset voltage	MO	I _{MO} =±20μA, I _{PD} =0mA (Note 3)		30	mV	
ΔV _M	Output voltage variance width	MO	I _{PD} =-0.2~2.0mA, I _{MO} =±20μA, R _M =1kΩ (Note 4)		20	mV	
		Temperature coefficient	R _M =1kΩ, I _{PD} =-1.2mA		0.05	mV/°C	
I _I	Input current	$\overline{\text{DATA}}$, V _{OFF}	V _I =2.7V		20	μA	
			V _I =0.4V		-0.2	mA	
			V _{L1} , V _{L2}	V _I =0~V _{CC}		±1	μA
V _{ref}	Reference voltage	Temperature coefficient	T _a =-20~75°C		1.2	mV/°C	
			T _a =25~75°C		-1.1		-0.7
I _{L1}	Output current 1 (Note 5)	LD	V _{L1} =3V, R _{C1} =560Ω, V _{LD} =2V		-62	mA	
			Temperature coefficient			0.037	mA/°C
I _{L2}	Output current 2 (Note 5)	LD	V _{L2} =3V, R _{C2} =560Ω, V _{LD} =2V		-31	mA	
			Temperature coefficient			0.017	mA/°C
I _{L3}	Output current 3 (Note 5)	LD	R _{C3} =360Ω, V _{LD} =2V		-31	mA	
I _{OFF}	Off-state output current	LD	V _{OFF} = $\overline{\text{DATA}}$ =2V		-0.2	-1	mA
			V _{OFF} = $\overline{\text{DATA}}$ =0.8V		-1	-20	μA
I _{CC}	Supply current		V _{CC} =5.25V, V _{OFF} =4.5V, V _{L1} =V _{L2} =3.0V, R _{C1} =R _{C2} =560Ω, R _{C3} =360Ω, 1R0, 2R0, LD open	$\overline{\text{DATA}}$ =0V	17	26	mA
				$\overline{\text{DATA}}$ =4.5V	30	44	

Note 3: I_{MO}: MO pin output current. I_{PD}: PD pin input current

4: R_M: Resistance connected between 1R_M and 2R_M pins.

5: This indicates the input voltage – output current conversion characteristic. Use I_{L1} to I_{L3} within the range of limits of the recommended operating conditions.

*: The standard value is given on V_{CC} = 5V and at T_a = 25°C. The items with T_a specified under test conditions are given on V_{CC} = 5V.

ELECTRICAL CHARACTERISTICS (VCC = 5V, Ta = 25°C)

Symbol	Parameter	Test pin		Test conditions	Limits			Unit
		Input	Output		Min.	Typ.	Max.	
f _{OP}	Operating frequency					20		Mbps
tr _{P1}	Circuit response time 1	V _{L1} /V _{L2} voltage	LD current	I _{LD(L)} =0mA, I _{LD(H)} =-60mA (Note 6)		4.5	7	μs
				I _{LD(L)} =-55mA, I _{LD(H)} =-65mA (Note 6)		0.5	2	
tr _{P2}	Circuit response time 2	PD current	MO voltage	I _{PD(L)} =0mA, I _{PD(H)} =-2mA, R _M =1kΩ (Note 7)		7	10	μs
				ΔI _{PD} =0.2mA, R _M =1kΩ (Note 7)		1	3	
tr _{P3}	Circuit response time 3	PD current	CO voltage	ΔI _{PD} =1mA (Note 7)		7	10	μs
				ΔI _{PD} =0.2mA (Note 7)		0.5	2	
t _{ON}	Circuit ON time	V _{OFF} voltage	LD current	I _{LD(H)} =-60mA (Note 8)		3	5	μs
t _{OFF}	Circuit OFF time	V _{OFF} voltage	LD current	I _{LD(H)} =-60mA (Note 8)		0.5	2	μs

NOTE 6: TEST CIRCUIT

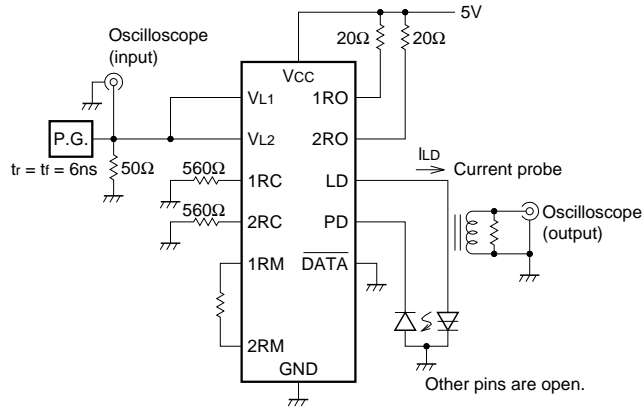

NOTE 7: TEST CIRCUIT

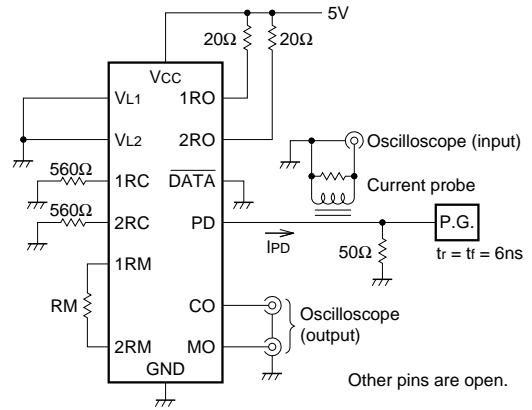

TIMING CHART

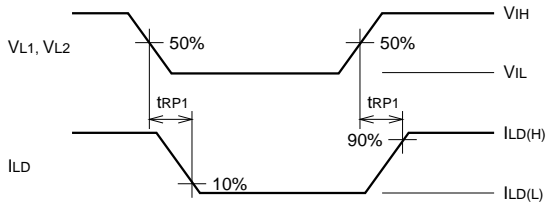

TIMING CHART

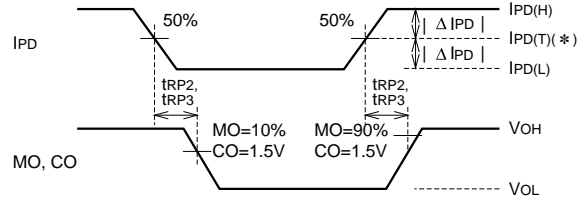

* : IPD when CO output is inverted.

NOTE 8: TEST CIRCUIT

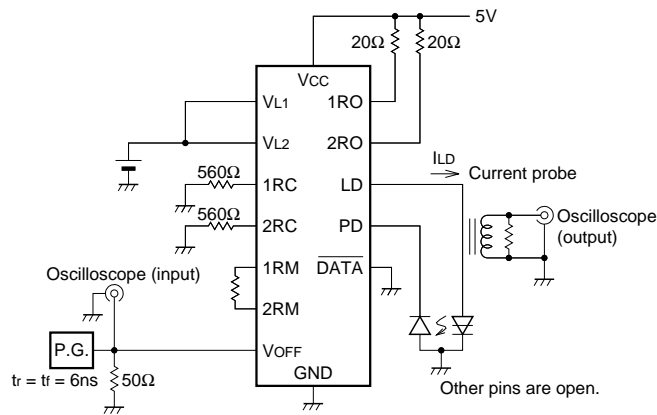

TIMING CHART

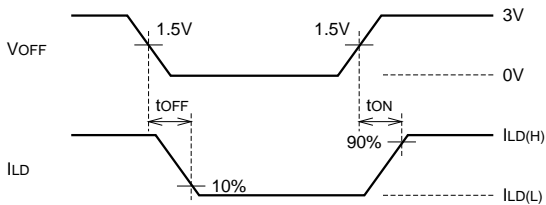

APPLICATION EXAMPLE

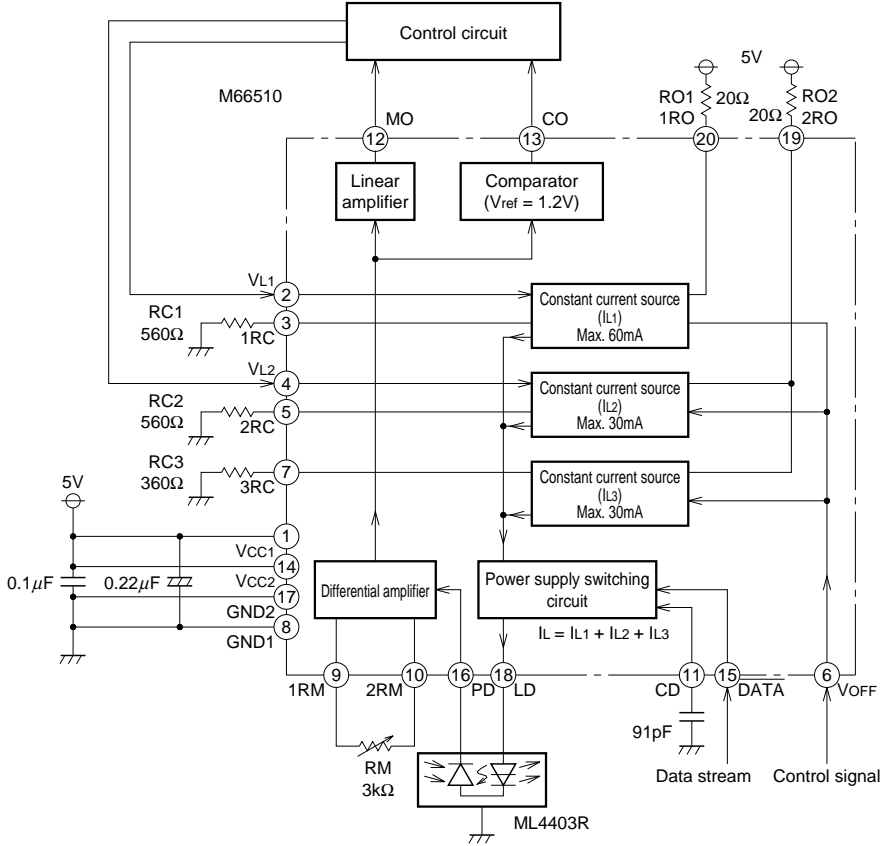

STANDARD CHARACTERISTICS (V_{CC} = 5V, T_a = 25°C)

LASER CURRENT - CURRENT SETTING VOLTAGE CHARACTERISTIC

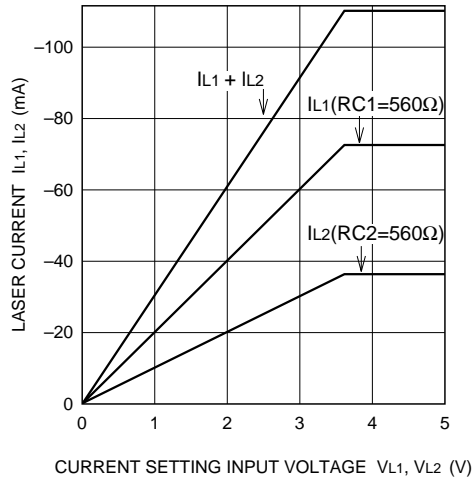

LASER CURRENT - RC3 RESISTANCE CHARACTERISTIC

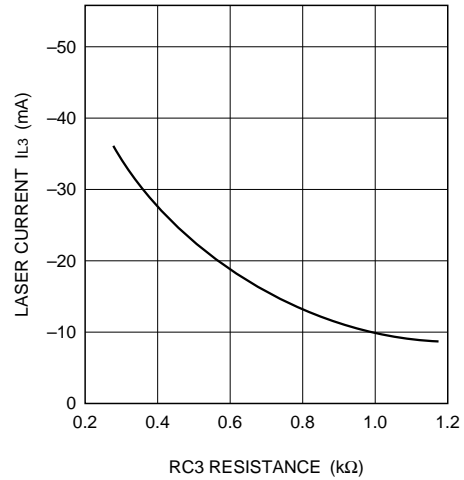

MO OUTPUT - MONITOR CURRENT CHARACTERISTIC

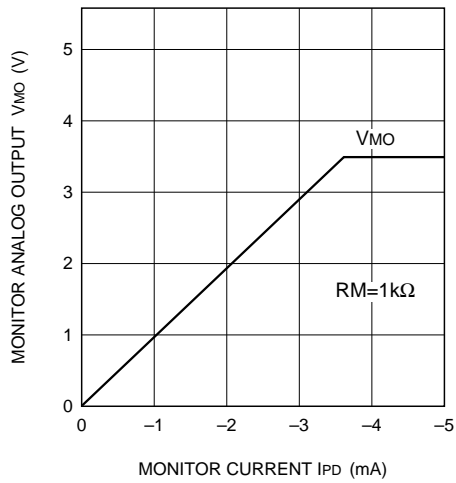

CO OUTPUT - MONITOR CURRENT CHARACTERISTIC

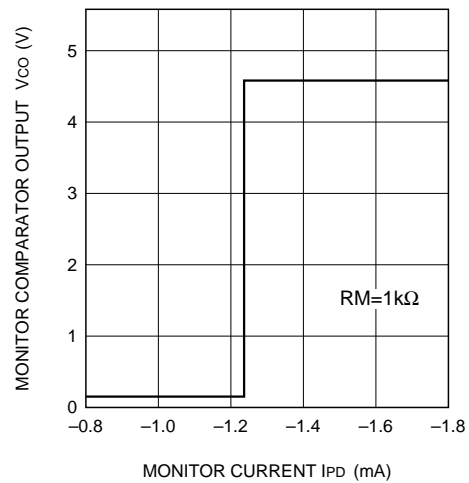

EVALUATION OF SWITCHING OPERATION WAVEFORM

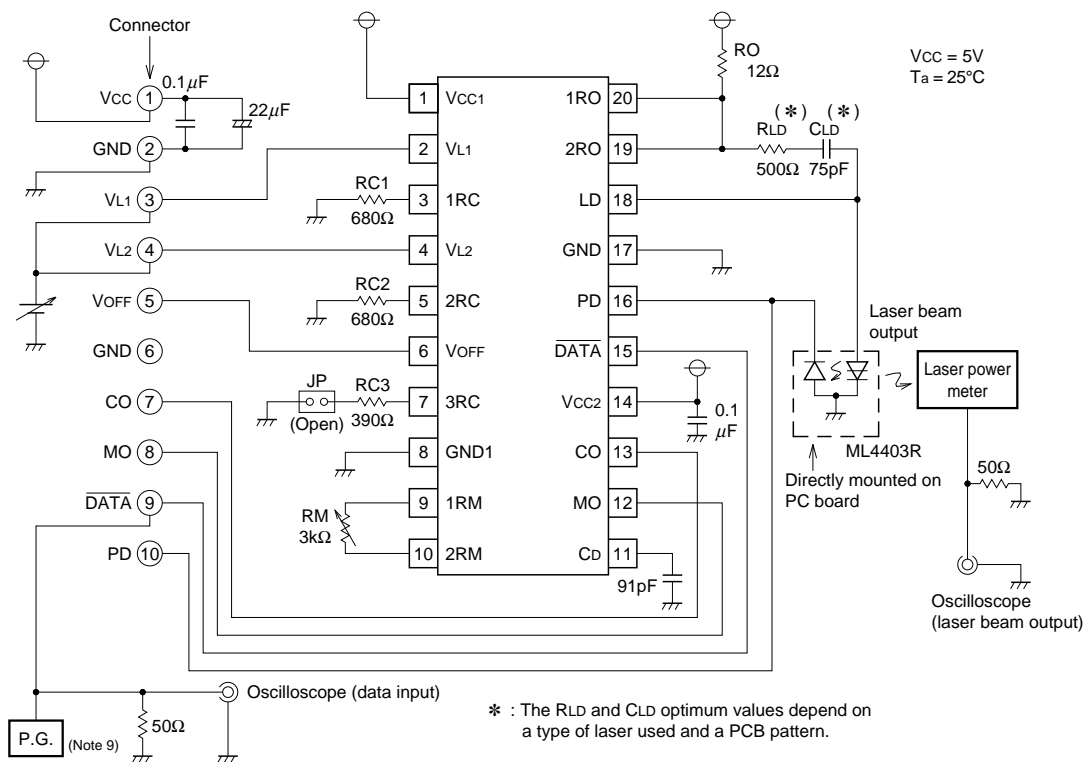

Note 9: tr = tf = 6ns, VO = 3Vp-p, duty = 50%

EVALUATION CIRCUIT

SWITCHING OPERATION WAVEFORM

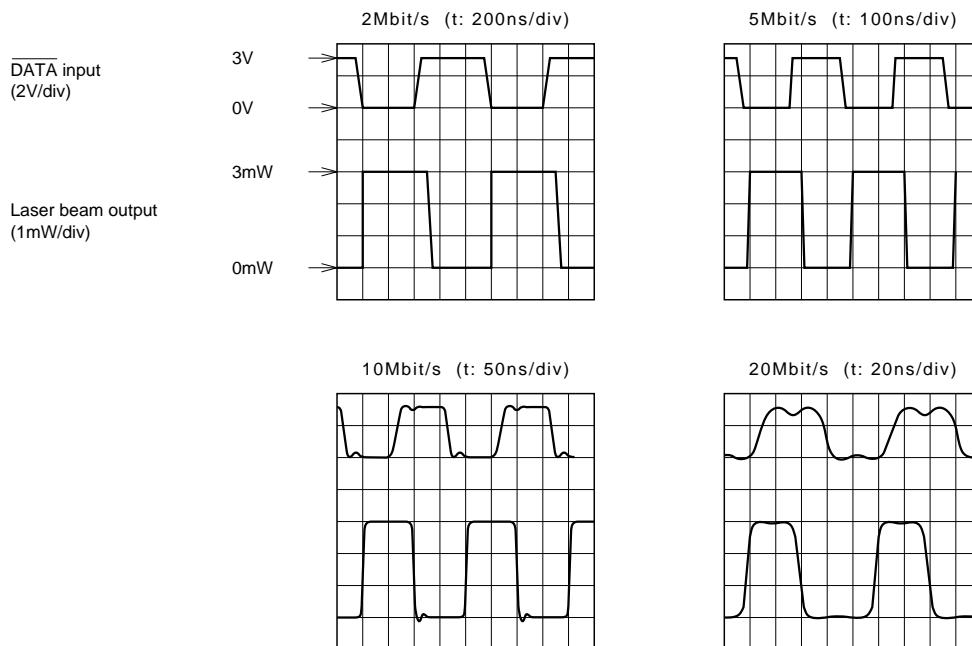

Note: The delay from DATA input to laser beam output includes a measurement delay.