

AN8267S

Fan Motor Driver

■ Overview

The AN8267S is an IC to drive the brushless DC fan motors for internally cooling or blowing the air to the office automation equipments and measuring equipments.

■ Features

- Operating supply voltage range : $V_{CC}=9.6$ to $27.6V$
(Operable at $V_{CC}=6V$ to $9.6V$ as well)
- 2-phase half-wave drive, built-in power transistor
- Built-in lock protective function and automatic reset function
- Built-in thermal protective circuit (operating temperature: $150^{\circ}C$ typ.)
- Built-in rotation display function

■ Application

For drive of brush-less DC fan motor

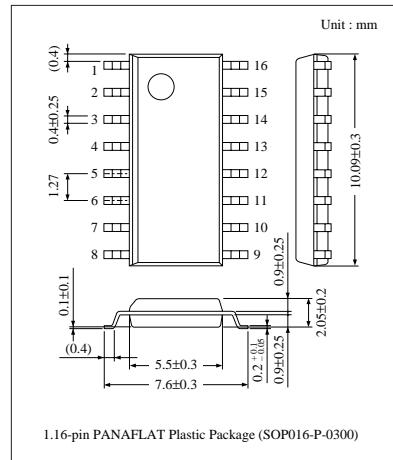

■ Block Diagram

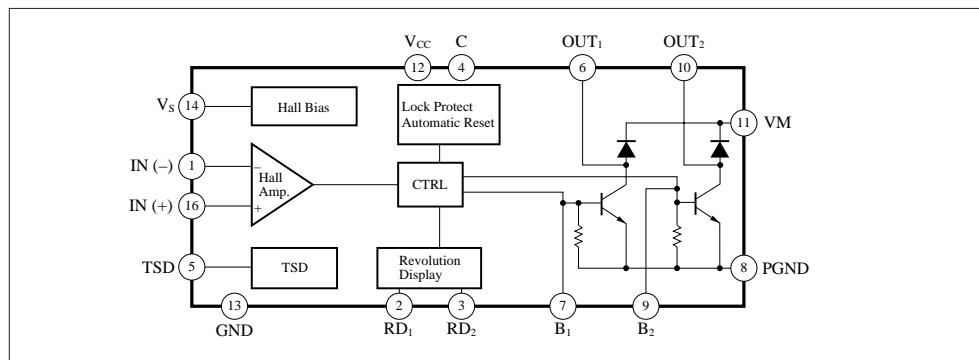

■ Absolute Maximum Ratings (Ta=25°C)

Parameter	Symbol	Rating	Unit
Supply voltage	V _{CC}	28.8	V
Supply current	I _{CC}	18	mA
Output current (t=0.1s)	I _{O(peak)}	1.5	A
Circuit current (Inflow current)	I ₂ , I ₃	10	mA
Circuit voltage (Applied voltage)	V ₂ , V ₃ , V ₆ , V ₁₀	55	V
Power dissipation	P _D	735 ^{Note 1)}	mW
Operating ambient temperature	T _{opr}	-30 to +80	°C
Storage temperature	T _{stg}	-55 to +150	°C

Note 1) When mounted to the glass epoxy PCB 50 × 50 × 0.8mm

■ Recommended Operating Range (Ta=25°C)

Parameter	Symbol	Range
Operating supply voltage range	V _{CC}	9.6V to 27.6V

■ Electrical Characteristics (Ta=25°C)

Parameter	Symbol	Condition	min	typ	max	Unit
Supply current	I _{CC}	V _{CC} =12V, R _L =OPEN	—	—	17	mA
Hall amp./Common mode input voltage	V _{HI}		2	—	V _{CC} -2	V
Input current	I _{HI}	V _{CC} =12V, V _{HI} =2V	—	—	50	μA
Hall bias voltage	V _{HB}	V _{CC} =12V, I _{HB} =-5mA	4	5	6	V
Output saturation voltage	V _{Osat}	V _{CC} =12V, I _O =0.5A	—	0.9	1.4	V
Leak current	I _{Oleak}	V _{CC} =12V, V _O =55V	—	—	100	μA
Bound protection Ct/Charging current	I _{tc}	V _{CC} =12V, V _t =0V	-12	-9.5	-7	μA
Bound protection Ct/Charging current	I _{td}	V _{CC} =12V, V _t =4.3V	0.95	1.3	1.65	μA
Threshold value voltage (1)	V _{tH}	V _{CC} =12V, Shut off	3.8	4.1	4.4	V
Threshold value voltage (2)	V _{tL}	V _{CC} =12V, Recovered	0.6	0.95	1.3	V
Rotation display/Output leak current	I _{OL3}	V _{CC} =12V, V _{OL} =55V	—	—	10	μA
Output voltage	V _{OL3}	V _{CC} =12V, I _{OL} =5mA	—	—	0.4	V
Rotation display/Output leak current	I _{OL2}	V _{CC} =12V, V _{OL} =55V	—	—	10	μA
Output voltage	V _{OL2}	V _{CC} =12V, I _{OL} =5mA	—	—	0.4	V

■ Application Circuit

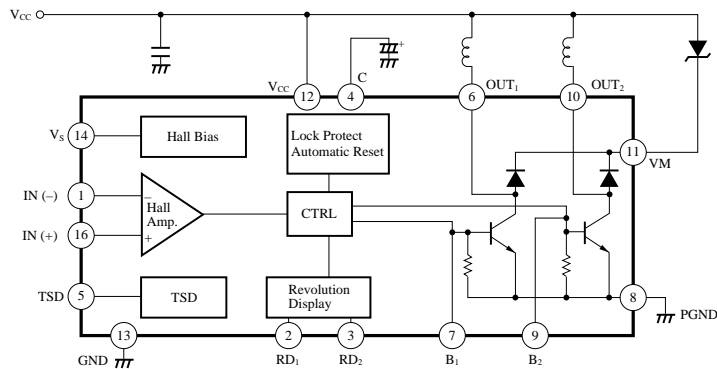

■ Pins Descriptions

Pin No.	Symbol	Pin name	Pin No.	Symbol	Pin name
1	IN (-)	Hall input (-)	9	B2	Output base 2
2	RD1	Rotation display 1 (pulse output)	10	OUT2	Motor coil output 2
3	RD2	Rotation display 2 (H/L output)	11	VM	Counter electromotive absorption
4	C	Lock protection automatic reset	12	V _{CC}	Supply voltage pin
5	TSD	Thermal shutdown	13	GND	Ground pin
6	OUT1	Motor coil output 1	14	VS	Hall bias
7	B1	Output base 1	15	NC	—
8	P. GND	Power ground	16	IN (+)	Hall input (+)

■ Supplementary Explanation

• Precautions for Using the AN8267S

Observe the following in order to use the AN8267S safely and properly.

Operating supply voltage range : 9.6V to 27.6V

1. Maximum applied voltage to the coil output Pins6 and 10

When driving the motor, the counter electromotive power of the coil is applied to the coil output Pins6 and 10 when the output transistor is turned off. (Refer to Fig.1)

With the AN8267S, see to it that this counter electromotive power will be 55V or less at maximum.

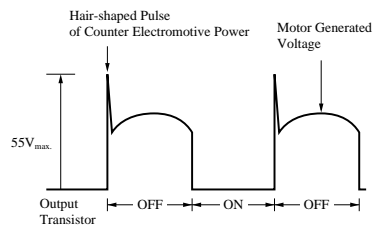

Fig.1 Coil Output Waveform (Suppressing the Counter Electromotive Power)

To suppress the counter electromotive power by the motor coil to 55V at maximum, do as follows.

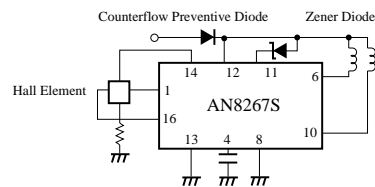

Fig.2

1) When using the Zener diode

Connect the Zener diode between the Pin11 of the AN8267S and the power line. The counter electromotive power which can be suppressed by the Zener diode is $V_{CC} - V_D + V_Z$. Since $V_{CCmax.} = 27.6V; V_{Zmax.} = 55V - 27.6V + 0.7V = 28.1V$

Therefore, if you keep V_Z at 28V or less, the counter electromotive power will not exceed 55V.

2) When using the capacitor

Connect the capacitor between the base and collector of the coil output transistor as shown in Fig.3.

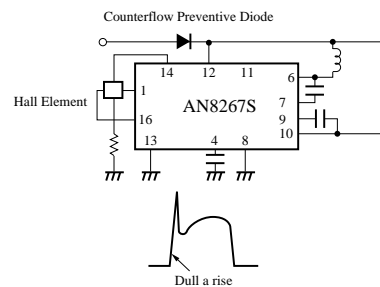

Fig.3

A capacitor value is as follows. C : 1,000pF to 10,000pF

C : 1000pF—10000pF

This capacitor can dull a rise of the counter electromotive power of the coil output. Select the capacitor so that maximum voltage of the counter electromotive power $V_{max.}$ will not exceed 55V.

■ Supplementary Explanation (Cont.)

2. Occurrence of radio noises

When driving the motor with the AN8267S, radio noises (noises which come out of the radio when the motor is driven near it) may occur.

The radio noises are more likely to occur as the counter electromotive power of the coil output pin rises more steeply. So, they can be eliminated by attaching the external part mentioned in 1-2) above.

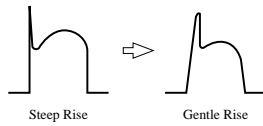

Fig.4

3. AN8267S lock protection

When the motor fan is locked, the AN8267S has a function to protect the motor and IC. (lock protection operational principle)

If the motor fan is locked, a sine wave signal is not input from the Hall element any more and the potential of the Pin4 external capacitor increases. (Fig.5a)

During this period, the IC is still supplying the coil current to rotate the motor fan. Then, if the voltage at the Pin4 reaches the reference voltage 1 set inside the IC, the electric charge in the external capacitor of the Pin4 is discharged constantly, thus reducing the voltage at the Pin4. (Fig.5b)

The IC stops supplying the coil current when this constant current discharge starts. If the voltage at the Pin4 reaches the reference voltage 2, the IC starts charging a constant current to the external capacitor of the Pin4 and supplies the coil current again, thus repeating the above-mentioned operation.

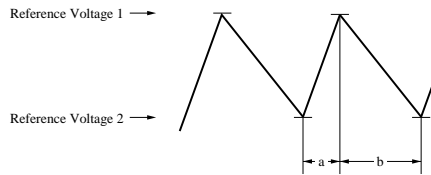

Fig.5

The external capacitor of the Pin4 is always kept in the discharge state by a signal from the Hall element at the time of stationary rotation.

When the lock protective function is being activated, coil current supply/stop intervals are about 1 : 7 in terms of time ratio.

Assuming the external capacitor of the Pin4 to be of 1μF, the supply/stop time ratio is about 0.3sec. : 2sec.

Lock Protective Function ON/OFF Time Calculation Expression

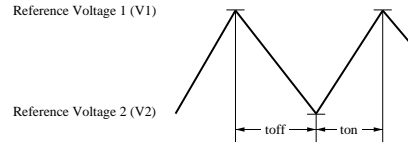

Fig.6

Assuming the charging current to be I_{ch} and the discharging current to be I_{DC} :

At charge time ;

$$V_1 - V_2 = \frac{1}{C} \int I_{ch} dt = \frac{I_{ch} \cdot t_{on}}{C}$$

$$\therefore t_{on} = \frac{(V_1 - V_2)}{I_{ch}} \cdot C$$

At discharge time

$$V_1 - V_2 = \frac{1}{C} \int I_{DC} dt = \frac{I_{DC} \cdot t_{off}}{C}$$

$$\therefore t_{off} = \frac{(V_1 - V_2)}{I_{DC}} \cdot C$$

Each value (typ.) of the AN8267S is ;

$$V_1 = 4V \quad I_{ch} = 9.5\mu A$$

$$V_2 = 0.95V \quad I_{DC} = 1.3\mu A$$

When $C = 1\mu F$;

$$t_{on} = 0.32s$$

$$t_{off} = 2.35s$$

C : External capacitor's capacity

4. Rotation output Pins2 and3

The Pins2 and 3 are of open collector output. The Pin2 is a pulse output pin synchronized with a signal from the Hall element. Therefore, the Pin2 is switched over depending on the polarities of the Hall input Pins1 and 16.

1	16	2
L	H	H
H	L	L

Polarities of Pins2, 1, and 16

■ Supplementary Explanation (Cont.)

The Pin3 is switched over in synchronization with coil current supply/stop.

1. Coil current ON :	L
2. Coil current OFF :	H

The maximum applied voltage for both Pins2 and 3 is 55V.

5. TSD (Thermal Shut Down)Pin5

The AN8267S incorporates the overheat protective circuit. If the chip temperature of the IC reaches 150°C (typ.), the coil current stops. Since the Pin5 is a TSD circuit operation checking pin, leave it "open" when the motor is driving normally.

6. Hall input Pins1 and 16

Input a sine wave signal from the Hall element to the Pins1 and 16.

The input DC voltage of those pins should be $2V_{min}$ or more.

It is recommended to connect the Hall element and DC bias resistor between the Pins1 and GND.

The Hall element sine wave signal V_i to be input to the Pins1 and 16 should be ; $15mV_{p-p} \leq V_i \leq 400mV_{p-p}$

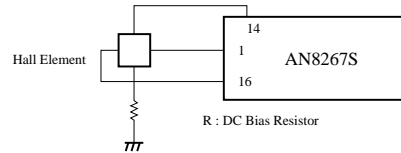

Fig.7

7. Precautions for wiring

When mounting the AN8267S onto the PCB, pay attention to the following points as to its wiring.

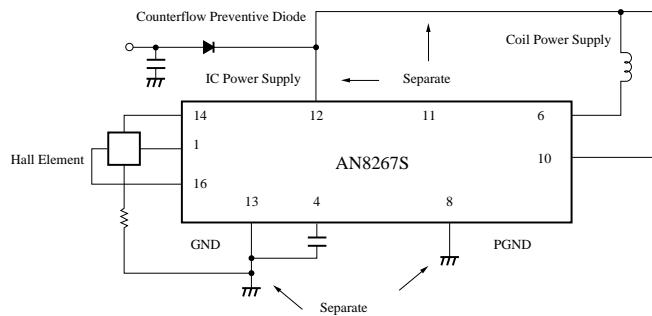

Fig.8

• power line

The power pin of the AN8267S is the Pin12. Separate it from the power line to the motor coil. Wiring to the motor coil should be made as thick and short as possible.

• GND line

The AN8267S has two GND Pins (8 and 13). Since the Pin8 serves as the GND pin for the coil output power transistor, separate from GND of the Pin13 as much as possible. Wiring to the Pin8 should be also as thick and short as possible.