

## Connectivity

- PCI r2.3 capable
- CompactPCI Hot Swappable
- 64-bit, 33MHz-133MHz Asynchronous operation
- 5V signal input tolerance and 5V signal to 3.3V signal conversions
- 27mm x 27mm PBGA
- 10KB FIFO size
- PCI-X or PCI Bus Types
- Transparent and Non-Transparent Bridge Function
- Support for 8 Bus Masters
- Usable in CPCI System Slot or Peripheral Slot

## Performance

- **Dynamic-Buffer-Management™** for enhanced PCI-X-to-PCI-X bridging
- **Smart-Prefetch™** allows the PCI 6540 to provide data prefetch, store and forward service to secondary bus PCI bus based processors
- **Flow-Thru™** architecture for PCI-X-to-PCI bridging
- Independent reference clock input for PCI-X clock speed measurement
- Large 10K Byte buffer for efficient PCI-X-to-PCI-X and PCI-X-to-PCI bridging and speed conversion
- 8 pairs of REQ/GNT signals support up to 8 bus masters directly on secondary bus
- EEPROM support for extra register control
- Vital Product Data (VPD)
- 16 general purpose IO interface
- PME D3 wakeup power



PLX Technology, Inc.  
870 Maude Ave.  
Sunnyvale, CA 94085 USA  
Tel: 1-800-759-3735  
Tel: 1-408-774-9060  
Fax: 1-408-774-2169

Email: [info@plxtech.com](mailto:info@plxtech.com)

Web Site: [www.plxtech.com](http://www.plxtech.com)

# PCI 6540

*Dual-Mode (Transparent & Non-Transparent) Universal FastLane™ PCI-X-to-PCI-X Bridge*

## Adaptive High Performance Asynchronous 133MHz, 64-bit, PCI-X-to-PCI-X Bridge for Servers, Storage, DSP, Telecommunication, Networking and Embedded Applications

PLX's FastLane™ PCI 6540 is a 64-Bit PCI-X-to-PCI-X bridge designed for high performance, high availability applications in PCI-X-to-PCI conversion, frequency conversions from a faster PCI-X to a slower PCI-X bus, address remapping, high availability hot swap, and universal system-to-system bridging.

The FastLane™ PCI 6540 includes sophisticated buffer management and buffer configuration options designed to provide customizable performance for efficient PCI-X-to-PCI conversion and processor bridging. The PCI 6540 allows up to 2KB prefetch during each PCI read and timed FIFO flush management.

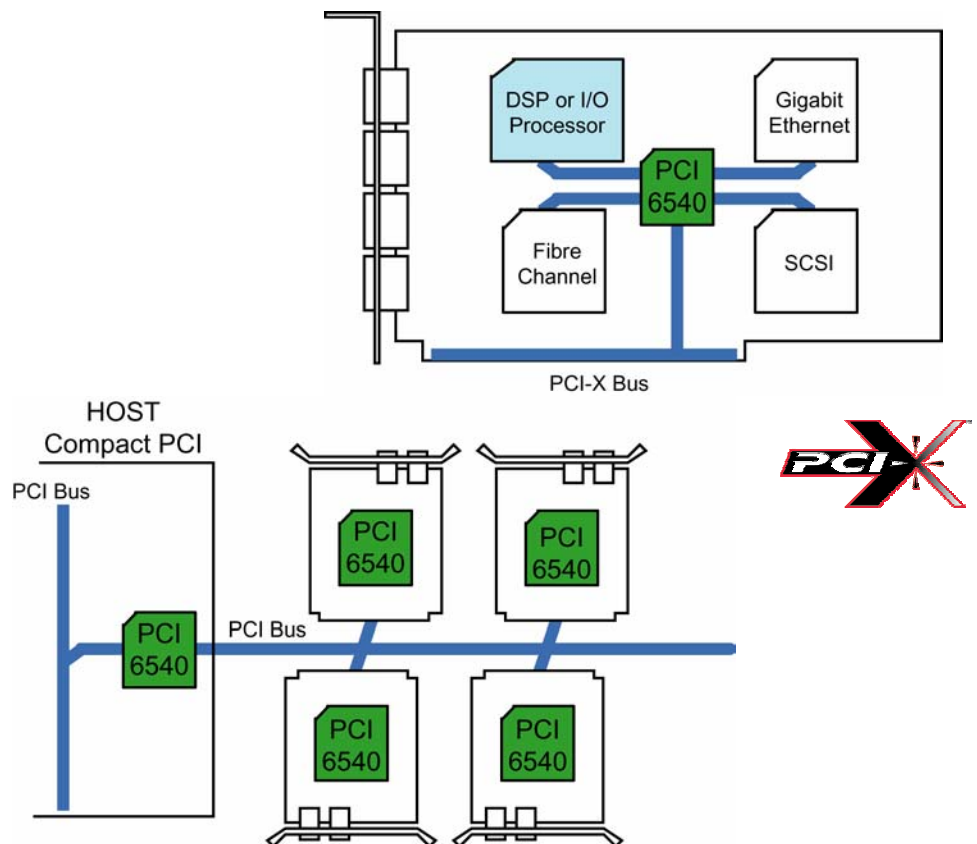

## Product Ordering Information

Part Number	Description
PCI 6540-xx13BC	PCI 6540 PCI-X-to-PCI-X Bridge Chip (PBGA)

Please visit the PLX Web site at <http://www.plxtech.com> or contact PLX sales at 408-774-9060 for more information.

© 2004 PLX Technology, Inc. All rights reserved. PLX and the PLX logo are registered trademarks of PLX Technology, Inc. FastLane is a trademark of PLX Technology, Inc., which may be registered in some jurisdiction. All other product names that appear in this material are for identification purposes only and are acknowledged to be trademarks or registered trademarks of their respective companies. Information supplied by PLX is believed to be accurate and reliable, but PLX Technology, Inc. assumes no responsibility for any errors that may appear in this material. PLX Technology, Inc. reserves the right, without notice, to make changes in product design or specification.