



# M48T513Y M48T513V

## 3.3V-5V 4 Mbit (512Kb x8) TIMEKEEPER<sup>®</sup> SRAM

- INTEGRATED ULTRA LOW POWER SRAM, REAL TIME CLOCK, POWER-FAIL CONTROL CIRCUIT, BATTERY, and CRYSTAL
- YEAR 2000 COMPLIANT
- BCD CODED CENTURY, YEAR, MONTH, DAY, DATE, HOURS, MINUTES, and SECONDS
- BATTERY LOW WARNING FLAG
- AUTOMATIC POWER-FAIL CHIP DESELECT and WRITE PROTECTION
- TWO WRITE PROTECT VOLTAGES: ( $V_{\text{PFD}}$  = Power-fail Deselect Voltage)
  - M48T513Y:  $4.2\text{V} \leq V_{\text{PFD}} \leq 4.5\text{V}$
  - M48T513V:  $2.7\text{V} \leq V_{\text{PFD}} \leq 3.0\text{V}$
- CONVENTIONAL SRAM OPERATION; UNLIMITED WRITE CYCLES
- SOFTWARE CONTROLLED CLOCK CALIBRATION for HIGH ACCURACY APPLICATIONS
- 10 YEARS of DATA RETENTION and CLOCK OPERATION in the ABSENCE of POWER
- SELF CONTAINED BATTERY and CRYSTAL in DIP PACKAGE
- MICROPROCESSOR POWER-ON RESET (Valid even during battery back-up mode)
- PROGRAMMABLE ALARM OUTPUT ACTIVE in BATTERY BACK-UP MODE
- SURFACE MOUNT CHIP SET PACKAGING INCLUDES a 44-PIN SOIC and a 32-LEAD TSOP (SNAPHAT TOP TO BE ORDERED SEPARATELY)
- SOIC PACKAGE PROVIDES DIRECT CONNECTION for a SNAPHAT TOP WHICH CONTAINS the BATTERY and CRYSTAL
- SNAPHAT<sup>®</sup> HOUSING (BATTERY/CRYSTAL) IS REPLACEABLE

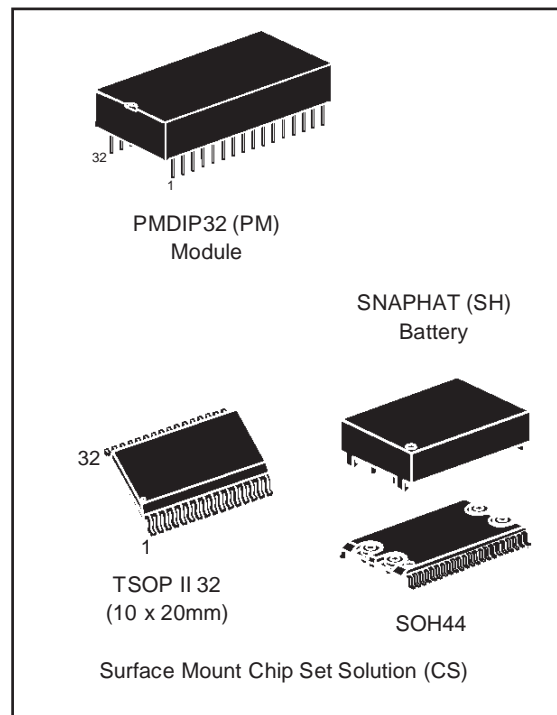
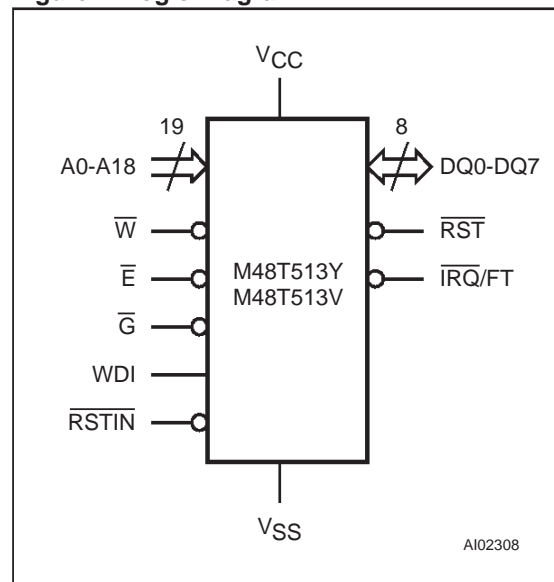

Figure 1. Logic Diagram



## M48T513Y, M48T513V

Figure 2. DIP Connections

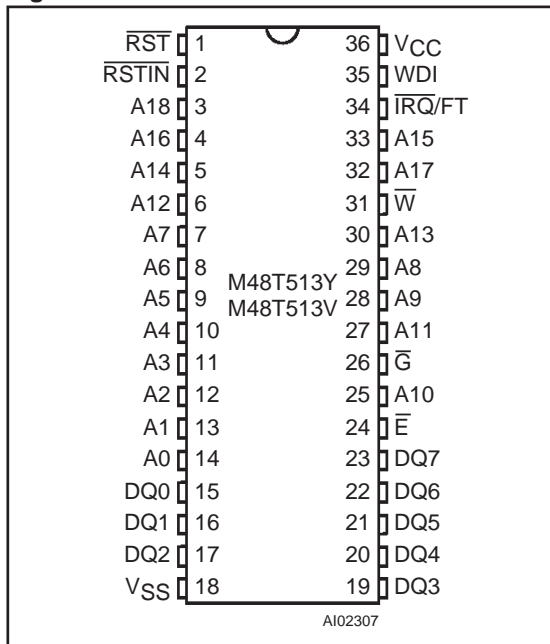

Table 1. Signal Names

A0-A18	Address Inputs
DQ0-DQ7	Data Inputs / Outputs
$\bar{E}$	Chip Enable Input
$\bar{G}$	Output Enable Input
$\bar{W}$	Write Enable Input
WDI	Watchdog input
$\bar{RST}$	Reset Output (open drain)
$\bar{RSTIN}$	Reset Input
$\bar{IRQ/FT}$	Interrupt / Frequency Test Output (open drain)
V <sub>CC</sub>	Supply Voltage
V <sub>SS</sub>	Ground

Table 2. Absolute Maximum Ratings <sup>(1)</sup>

Symbol	Parameter	Value	Unit
T <sub>A</sub>	Ambient Operating Temperature	0 to 70	°C
T <sub>STG</sub>	Storage Temperature (V <sub>CC</sub> Off, Oscillator Off)	-40 to 85	°C
V <sub>IO</sub>	Input or Output Voltages	-0.3 to V <sub>CC</sub> +0.3	V
V <sub>CC</sub>	Supply Voltage	M48T513Y	-0.3 to 7.0
		M48T513V	-0.3 to 4.6
I <sub>O</sub>	Output Current	20	mA
P <sub>D</sub>	Power Dissipation	1	W

Note: 1. Stresses greater than those listed under "Absolute Maximum Ratings" may cause permanent damage to the device. This is a stress rating only and functional operation of the device at these or any other conditions above those indicated in the operational section of this specification is not implied. Exposure to the absolute maximum rating conditions for extended periods of time may affect reliability.

2. Soldering temperature not to exceed 260°C for 10 seconds (total thermal budget not to exceed 150°C for longer than 30 seconds).

**CAUTION:** Negative undershoots below -0.3V are not allowed on any pin while in the Battery Back-up mode.

### DESCRIPTION

The M48T513Y/V TIMEKEEPER RAM is a 512Kb x 8 non-volatile static RAM and real time clock, with programmable alarms and a watchdog timer. The special DIP package provides a fully integrated battery back-up memory and real time clock solution. The M48T513Y/V directly replaces industry standard 512Kb x 8 SRAM. It also provides the non-volatility of Flash without any requirement for special write timing or limitations on the number of writes that can be performed.

For surface mount environments ST provides a Chip Set solution consisting of a 44 pin 330mil SOIC TIMEKEEPER Supervisor (M48T201V/Y) and a 32 pin TSOP Type II (10 x 20mm) LPSRAM (M68Z512/W) packages.

The 44 pin 330mil SOIC provides sockets with gold plated contacts at both ends for direct connection to a separate SNAPHAT housing containing the battery.

Figure 3. Block Diagram

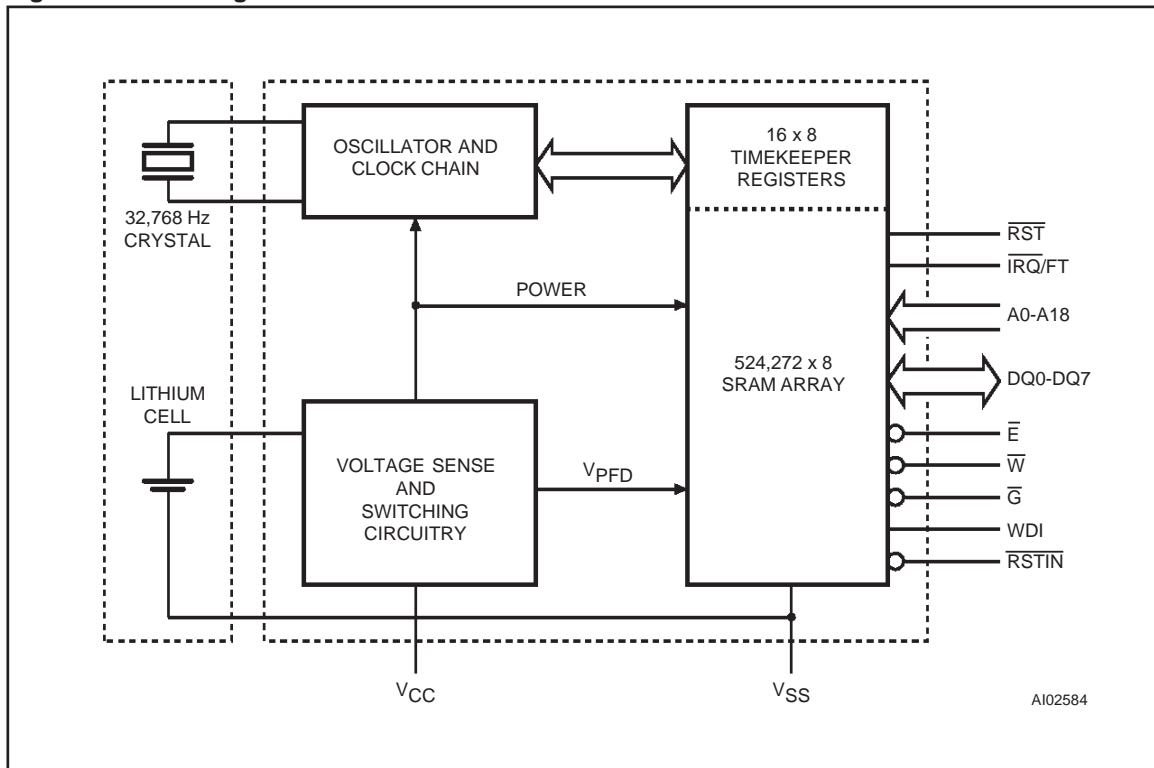

The unique design allows the SNAPHAT battery package to be mounted on top of the SOIC package after the completion of the surface mount process. Insertion of the SNAPHAT housing after reflow prevents potential battery damage due to the high temperatures required for device surface-mounting. The SNAPHAT housing is keyed to prevent reverse insertion.

The SNAPHAT battery package is shipped separately in plastic anti-static tubes or in Tape & Reel form. The part number is "M4Txx-BR12SH1".

Figure 3 illustrates the static memory array and the quartz controlled clock oscillator. The clock locations contain the century, year, month, date, day, hour, minute, and second in 24 hour BCD format. Corrections for 28, 29 (leap year), 30, and 31 day months are made automatically. The nine clock bytes (7FFFh-7FFF9h and 7FFF1h) are not the actual clock counters, they are memory locations consisting of BiPORT™ read/write memory cells within the static RAM array.

The M48T513Y/V includes a clock control circuit which updates the clock bytes with current information once per second. The information can be accessed by the user in the same manner as any

other location in the static memory array. Byte 7FFF8h is the clock control register. This byte controls user access to the clock information and also stores the clock calibration setting.

Byte 7FFF7h contains the watchdog timer setting. The watchdog timer can generate either a reset or an interrupt, depending on the state of the Watchdog Steering bit (WDS). Bytes 7FFF6h-7FFF2h include bits that, when programmed, provide for clock alarm functionality. Alarms are activated when the register content matches the month, date, hours, minutes, and seconds of the clock registers. Byte 7FFF1h contains century information. Byte 7FFF0h contains additional flag information pertaining to the watchdog timer, the alarm condition and the battery status. The M48T513Y/V also has its own Power-Fail Detect circuit. This control circuitry constantly monitors the supply voltage for an out of tolerance condition. When  $V_{CC}$  is out of tolerance, the circuit write protects the TIMEKEEPER register data and external SRAM, providing data security in the midst of unpredictable system operation. As  $V_{CC}$  falls, the control circuitry automatically switches to the battery, maintaining data and clock operation until valid power is restored.

Figure 4. Hardware Hookup for SMT Chip Set <sup>(1)</sup>

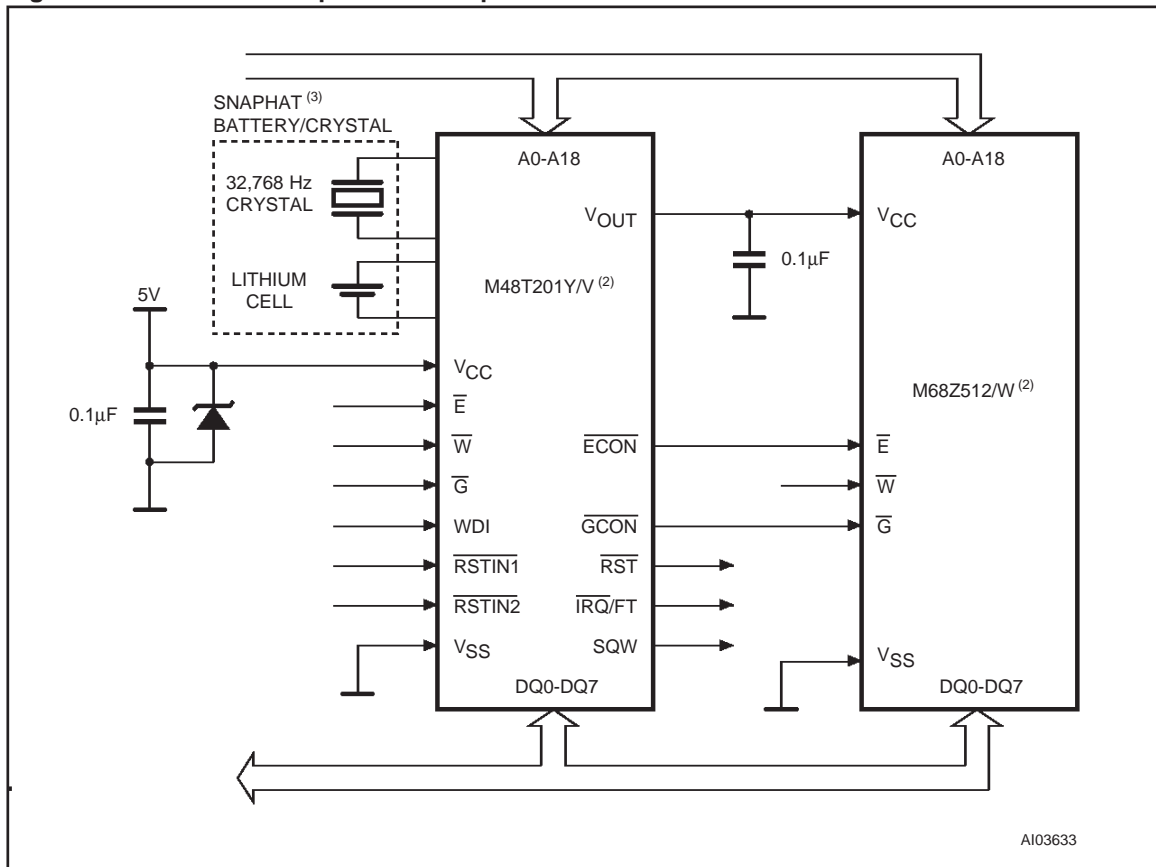

Note: 1. For pin connections, see individual data sheets for M48T201Y/V and M68Z512/W at [www.st.com](http://www.st.com).  
 2. For 5V, M48T129Y (M48T201Y + M68Z512). For 3.3V, M48T129V (M48T201V + M68Z512W).  
 3. SNAPHAT Top ordered separately.

**READ MODE**

The M48T513Y/V is in the Read Mode whenever  $\overline{W}$  (Write Enable) is high and  $\overline{E}$  (Chip Enable) is low. The unique address specified by the 17 Address Inputs defines which one of the 524,272 bytes of data is to be accessed. Valid data will be available at the Data I/O pins within  $t_{AVQV}$  (Address Access Time) after the last address input signal is stable, providing the  $\overline{E}$  and  $\overline{G}$  access times are also satisfied. If the  $\overline{E}$  and  $\overline{G}$  access times are not met, valid data will be available after the latter of the Chip Enable Access Times ( $t_{ELQV}$ ) or Output Enable Access Time ( $t_{GLQV}$ ). The state of the eight three-state Data I/O signals is controlled by  $\overline{E}$  and  $\overline{G}$ . If the outputs are activated before  $t_{AVQV}$ , the data lines will be driven to an indeterminate state until  $t_{AVQV}$ . If the Address Inputs are changed while  $\overline{E}$  and  $\overline{G}$  remain active, output data will remain valid for  $t_{AXQX}$  (Output

Data Hold Time) but will go indeterminate until the next Address Access.

**WRITE MODE**

The M48T513Y/V is in the Write Mode whenever  $\overline{W}$  (Write Enable) and  $\overline{E}$  (Chip Enable) are low state after the address inputs are stable. The start of a write is referenced from the latter occurring falling edge of  $\overline{W}$  or  $\overline{E}$ . A write is terminated by the earlier rising edge of  $\overline{W}$  or  $\overline{E}$ . The addresses must be held valid throughout the cycle.  $\overline{E}$  or  $\overline{W}$  must return high for a minimum of  $t_{EHAX}$  from Chip Enable or  $t_{WHAX}$  from Write Enable prior to the initiation of another read or write cycle. Data-in must be valid  $t_{DVWH}$  prior to the end of write and remain valid for  $t_{WHDX}$  afterward.  $\overline{G}$  should be kept high during write cycles to avoid bus contention; although, if the output bus has been activated by a low on  $\overline{E}$  and  $\overline{G}$  a low on  $\overline{W}$  will disable the outputs  $t_{WLQZ}$  after  $\overline{W}$  falls.



Table 3. Operating Modes (1)

Mode	V <sub>CC</sub>	$\bar{E}$	$\bar{G}$	$\bar{W}$	DQ0-DQ7	Power
Deselect	4.5V to 5.5V or 3.0V to 3.6V	V <sub>IH</sub>	X	X	High Z	Standby
Write		V <sub>IL</sub>	X	V <sub>IL</sub>	D <sub>IN</sub>	Active
Read		V <sub>IL</sub>	V <sub>IL</sub>	V <sub>IH</sub>	D <sub>OUT</sub>	Active
Read		V <sub>IL</sub>	V <sub>IH</sub>	V <sub>IH</sub>	High Z	Active
Deselect	V <sub>SO</sub> to V <sub>PFD</sub> (min) (2)	X	X	X	High Z	CMOS Standby
Deselect	≤ V <sub>SO</sub> (2)	X	X	X	High Z	Battery Back-up Mode

Note: 1. X = V<sub>IH</sub> or V<sub>IL</sub>; V<sub>SO</sub> = Battery Back-up Switchover Voltage.  
2. See Table 7 for details.

### DATA RETENTION MODE

With valid V<sub>CC</sub> applied, the M48T513Y/V operates as a conventional BYTEWIDE static RAM. Should the supply voltage decay, the RAM will automatically deselect, write protecting itself when V<sub>CC</sub> falls between V<sub>PFD</sub> (max), V<sub>PFD</sub> (min) window. All outputs become high impedance and all inputs are treated as "don't care".

**Note:** A power failure during a write cycle may corrupt data at the current addressed location, but does not jeopardize the rest of the RAM's content. At voltages below V<sub>PFD</sub> (min), the memory will be in a write protected state, provided the V<sub>CC</sub> fall time is not less than t<sub>F</sub>. The M48T513Y/V may respond to transient noise spikes on V<sub>CC</sub> that cross into the deselect window during the time the device is sampling V<sub>CC</sub>. Therefore, decoupling of the power supply lines is recommended.

When V<sub>CC</sub> drops below V<sub>SO</sub>, the control circuit switches power to the internal battery, preserving data and powering the clock. The internal energy source will maintain data in the M48T513Y/V for an accumulated period of at least 10 years at room temperature. As system power rises above V<sub>SO</sub>, the battery is disconnected, and the power supply is switched to external V<sub>CC</sub>. Deselect continues for t<sub>REC</sub> after V<sub>CC</sub> reaches V<sub>PFD</sub> (max). For a further more detailed review of lifetime calculations, please see Application Note AN1012.

### TIMEKEEPER REGISTERS

The M48T513Y/V offers 16 internal registers which contain TIMEKEEPER, Alarm, Watchdog, Interrupt, Flag, and Control data. These registers are memory locations which contain external (user accessible) and internal copies of the data (usually

Table 4. AC Measurement Conditions

Input Rise and Fall Times	≤ 5ns
Input Pulse Voltages	0 to 3V
Input and Output Timing Ref. Voltages	1.5V

Note that Output Hi-Z is defined as the point where data is no longer driven.

Figure 5. AC Testing Load Circuit

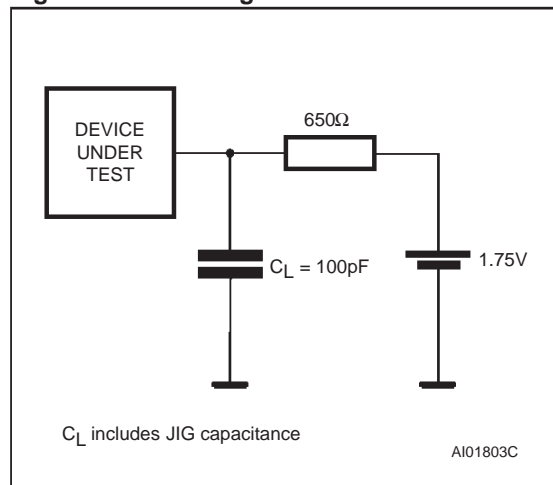

Note: Excluding open drain output pins.

referred to as BiPORT™ TIMEKEEPER cells). The external copies are independent of internal functions except that they are updated periodically by the simultaneous transfer of the incremented internal copy. TIMEKEEPER and Alarm Registers store data in BCD.

### CLOCK OPERATIONS

#### Reading the Clock

Updates to the TIMEKEEPER registers should be halted before clock data is read to prevent reading data in transition. Because the BiPORT TIMEKEEPER cells in the RAM array are only data registers, and not the actual clock counters, updating the registers can be halted without disturbing the clock itself.

Updating is halted when a '1' is written to the READ bit, D6 in the Control Register (7FFF8h). As long as a '1' remains in that position, updating is halted. After a halt is issued, the registers reflect the count; that is, the day, date, and time that were current at the moment the halt command was issued. All of the TIMEKEEPER registers are updated simultaneously. A halt will not interrupt an update in progress. Updating occurs 1 second after the READ bit is reset to a '0'.

#### Setting the Clock

Bit D7 of the Control Register (7FFF8h) is the WRITE bit. Setting the WRITE bit to a '1', like the READ bit, halts updates to the TIMEKEEPER registers. The user can then load them with the correct day, date, and time data in 24 hour BCD format (see Table 11).

Resetting the WRITE bit to a '0' then transfers the values of all time registers (7FFFh-7FFF9h, 7FFF1h) to the actual TIMEKEEPER counters and allows normal operation to resume. After the WRITE bit is reset, the next clock update will occur approximately one second later.

**Note:** Upon power-up following a power failure, both the WRITE bit and the READ bit will be reset to '0'.

#### Stopping and Starting the Oscillator

The oscillator may be stopped at any time. If the device is going to spend a significant amount of time on the shelf, the oscillator can be turned off to minimize current drain on the battery. The STOP bit is located at Bit D7 within 7FFF9h. Setting it to a '1' stops the oscillator. When reset to a '0', the M48T513Y/V oscillator starts within one second.

**Note:** It is not necessary to set the WRITE bit when setting or resetting the FREQUENCY TEST bit (FT) or the STOP bit (ST).

### SETTING ALARM CLOCK

Registers 7FFF6h-7FFF2h contain the alarm settings. The alarm can be configured to go off at a prescribed time on a specific month, date, hour, minute, or second or repeat every month, day, hour, minute, or second. It can also be programmed to go off while the M48T513Y/V is in the battery back-up to serve as a system wake-up call.

Bits RPT5-RPT1 put the alarm in the repeat mode of operation. Table 12 shows the possible configurations. Codes not listed in the table default to the once per second mode to quickly alert the user of an incorrect alarm setting.

**Note:** User must transition address (or toggle Chip Enable) to see Flag Bit change.

When the clock information matches the alarm clock settings based on the match criteria defined by RPT5-RPT1, the AF (Alarm Flag) is set. If AFE (Alarm Flag Enable) is also set, the alarm condition activates the  $\overline{\text{IRQ/FT}}$  pin. To disable alarm, write '0' to the Alarm Date register and RPT1-4. The  $\overline{\text{IRQ/FT}}$  output is cleared by a read to the Flags register as shown in Figure 12. A subsequent read of the Flags register will reset the Alarm Flag (D6; Register 7FFF0h).

The  $\overline{\text{IRQ/FT}}$  pin can also be activated in the battery back-up mode. The  $\overline{\text{IRQ/FT}}$  will go low if an alarm occurs and both ABE (Alarm in Battery Back-up Mode Enable) and AFE are set. The ABE and AFE bits are reset during power-up, therefore an alarm generated during power-up will only set AF. The user can read the Flag Register at system boot-up to determine if an alarm was generated while the M48T513Y/V was in the deselect mode during power-up. Figure 13 illustrates the back-up mode alarm timing.

### WATCHDOG TIMER

The watchdog timer can be used to detect an out-of-control microprocessor. The user programs the watchdog timer by setting the desired amount of time-out into the Watchdog Register, address 7FFF7h. Bits BMB4-BMB0 store a binary multiplier and the two lower order bits RB1-RB0 select the resolution, where 00 = 1/16 second, 01 = 1/4 second, 10 = 1 second, and 11 = 4 seconds. The amount of time-out is then determined to be the multiplication of the five bit multiplier value with the resolution. (For example: writing 00001110 in the Watchdog Register =  $3 \times 1$  or 3 seconds).

**Note:** Accuracy of timer is within  $\pm$  the selected resolution.

**Table 5. Capacitance <sup>(1)</sup>**  
(T<sub>A</sub> = 25 °C, f = 1 MHz)

Symbol	Parameter	Test Condition	Min	Max	Unit
C <sub>IN</sub>	Input Capacitance	V <sub>IN</sub> = 0V		20	pF
C <sub>IO</sub> <sup>(2)</sup>	Input / Output Capacitance	V <sub>OUT</sub> = 0V		20	pF

Note: 1. Effective capacitance measured with power supply at 5V (M48T513Y) or 3.3V (M48T513V). Sampled only, not 100% tested.  
2. Outputs deselected.

**Table 6A. DC Characteristics - M48T513Y**  
(T<sub>A</sub> = 0 to 70 °C; V<sub>CC</sub> = 4.5V to 5.5V)

Symbol	Parameter	Test Condition	Min	Max	Unit
I <sub>LI</sub> <sup>(1)</sup>	Input Leakage Current	0V ≤ V <sub>IN</sub> ≤ V <sub>CC</sub>		±2	μA
I <sub>LO</sub> <sup>(1)</sup>	Output Leakage Current	0V ≤ V <sub>OUT</sub> ≤ V <sub>CC</sub>		±2	μA
I <sub>CC</sub>	Supply Current	Outputs open		115	mA
I <sub>CC1</sub>	Supply Current (Standby) TTL	$\bar{E} = V_{IH}$		8	mA
I <sub>CC2</sub>	Supply Current (Standby) CMOS	$\bar{E} = V_{CC} - 0.2V$		4	mA
V <sub>IL</sub>	Input Low Voltage		-0.3	0.8	V
V <sub>IH</sub>	Input High Voltage		2.2	V <sub>CC</sub> + 0.3	V
V <sub>OL</sub>	Output Low Voltage	I <sub>OL</sub> = 2.1mA		0.4	V
V <sub>OH</sub>	Output High Voltage	I <sub>OH</sub> = -1mA	2.4		V

Note: 1. Outputs deselected.

**Table 6B. DC Characteristics - M48T513V**  
(T<sub>A</sub> = 0 to 70 °C; V<sub>CC</sub> = 3.0V to 3.6V)

Symbol	Parameter	Test Condition	Min	Max	Unit
I <sub>LI</sub> <sup>(1)</sup>	Input Leakage Current	0V ≤ V <sub>IN</sub> ≤ V <sub>CC</sub>		±2	μA
I <sub>LO</sub> <sup>(1)</sup>	Output Leakage Current	0V ≤ V <sub>OUT</sub> ≤ V <sub>CC</sub>		±2	μA
I <sub>CC</sub>	Supply Current	Outputs open		60	mA
I <sub>CC1</sub>	Supply Current (Standby) TTL	$\bar{E} = V_{IH}$		4	mA
I <sub>CC2</sub>	Supply Current (Standby) CMOS	$\bar{E} = V_{CC} - 0.2V$		3	mA
V <sub>IL</sub>	Input Low Voltage		-0.3	0.4	V
V <sub>IH</sub>	Input High Voltage		2.2	V <sub>CC</sub> + 0.3	V
V <sub>OL</sub>	Output Low Voltage	I <sub>OL</sub> = 2.1mA		0.4	V
V <sub>OH</sub>	Output High Voltage	I <sub>OH</sub> = -1mA	2.2		V

Note: 1. Outputs deselected.

Figure 6. Power Down/Up Mode AC Waveforms

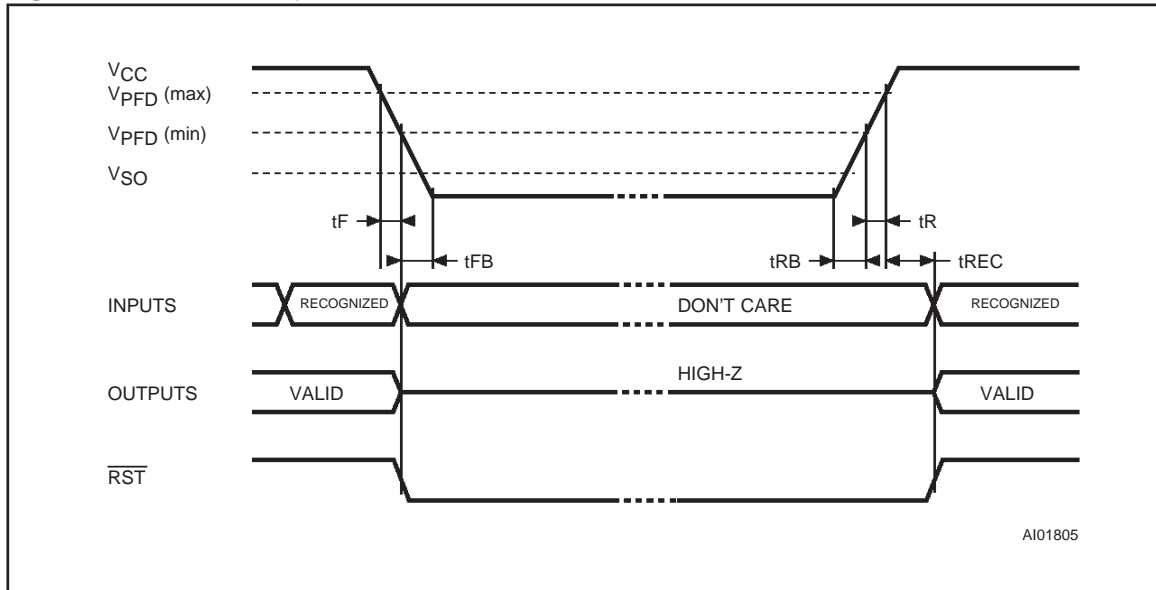

Table 7. Power Down/Up Trip Points DC Characteristics <sup>(1)</sup>  
(T<sub>A</sub> = 0 to 70 °C)

Symbol	Parameter	Min	Typ	Max	Unit	
V <sub>PFD</sub>	Power-fail Deselect Voltage	M48T513Y	4.2	4.35	4.5	V
		M48T513V	2.7	2.9	3.0	V
V <sub>SO</sub>	Battery Back-up Switchover Voltage	M48T513Y		3.0		V
		M48T513V		V <sub>PFD</sub> - 100mV		
t <sub>DR</sub> <sup>(2)</sup>	Expected Data Retention Time	10			YEARS	

Note: 1. All voltages referenced to V<sub>SS</sub>.  
2. At 25°C.

Table 8. Power Down/Up AC Characteristics  
(T<sub>A</sub> = 0 to 70 °C)

Symbol	Parameter	Min	Max	Unit
t <sub>F</sub> <sup>(1)</sup>	V <sub>PFD</sub> (max) to V <sub>PFD</sub> (min) V <sub>CC</sub> Fall Time	300		μs
t <sub>FB</sub> <sup>(2)</sup>	V <sub>PFD</sub> (min) to V <sub>SS</sub> V <sub>CC</sub> Fall Time	M48T513Y	10	μs
		M48T513V	150	μs
t <sub>R</sub>	V <sub>PFD</sub> (min) to V <sub>PFD</sub> (max) V <sub>CC</sub> Rise Time	0		μs
t <sub>RB</sub>	V <sub>SS</sub> to V <sub>PFD</sub> (min) V <sub>CC</sub> Rise Time	1		μs
t <sub>REC</sub>	V <sub>PFD</sub> (max) to $\overline{\text{RST}}$ High	40	200	ms

Note: 1. V<sub>PFD</sub> (max) to V<sub>PFD</sub> (min) fall time of less than t<sub>F</sub> may result in deselection/write protection not occurring until 200ms after V<sub>CC</sub> passes V<sub>PFD</sub> (min).  
2. V<sub>PFD</sub> (min) to V<sub>SS</sub> fall time of less than t<sub>FB</sub> may cause corruption of RAM data.

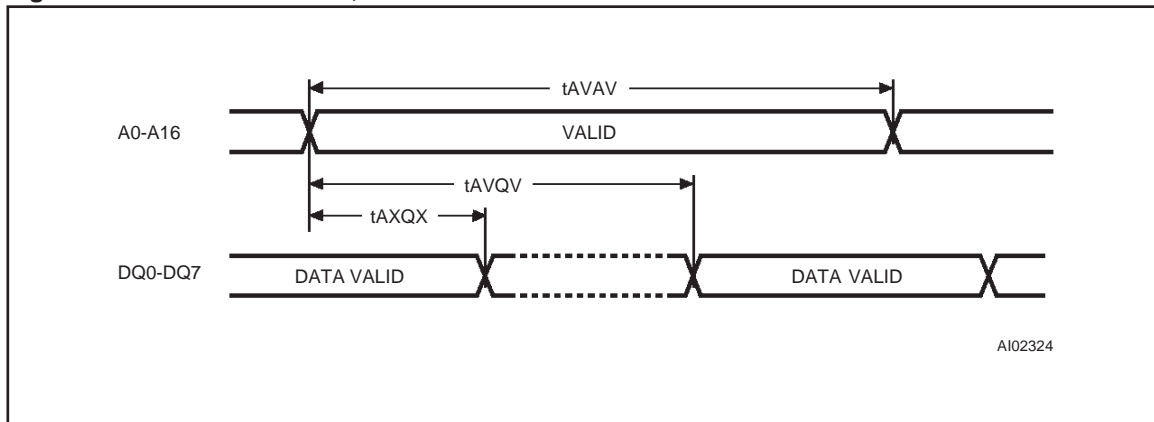

**Table 9. Read Mode AC Characteristics**  
( $T_A = 0$  to  $70$  °C)

Symbol	Parameter	M48T513Y		M48T513V		Unit
		-70		-85		
		Min	Max	Min	Max	
$t_{AVAV}$	Read Cycle Time	70		85		ns
$t_{AVQV}^{(1)}$	Address Valid to Output Valid		70		85	ns
$t_{ELQV}^{(1)}$	Chip Enable Low to Output Valid		70		85	ns
$t_{GLQV}^{(1)}$	Output Enable Low to Output Valid		40		55	ns
$t_{ELQX}^{(2)}$	Chip Enable Low to Output Transition	5		5		ns
$t_{GLQX}^{(2)}$	Output Enable Low to Output Transition	5		5		ns
$t_{EHQZ}^{(2)}$	Chip Enable High to Output Hi-Z		25		30	ns
$t_{GHQZ}^{(2)}$	Output Enable High to Output Hi-Z		25		30	ns
$t_{AXQX}^{(1)}$	Address Transition to Output Transition	10		5		ns

Note: 1.  $C_L = 100$ pF.  
2.  $C_L = 5$ pF.

**Figure 7. Address Controlled, Read Mode AC Waveforms**



**Table 10. Write Mode AC Characteristics**  
 (T<sub>A</sub> = 0 to 70 °C)

Symbol	Parameter	M48T513Y		M48T513V		Unit
		-70		-85		
		Min	Max	Min	Max	
t <sub>AVAV</sub>	Write Cycle Time	70		85		ns
t <sub>AVWL</sub>	Address Valid to Write Enable Low	0		0		ns
t <sub>AVEL</sub>	Address Valid to Chip Enable Low	0		0		ns
t <sub>WLWH</sub>	Write Enable Pulse Width	50		60		ns
t <sub>ELEH</sub>	Chip Enable Low to Chip Enable High	55		65		ns
t <sub>WHAX</sub>	Write Enable High to Address Transition	5		5		ns
t <sub>EHAX</sub>	Chip Enable High to Address Transition	10		15		ns
t <sub>DVWH</sub>	Input Valid to Write Enable High	30		35		ns
t <sub>DVEH</sub>	Input Valid to Chip Enable High	30		35		ns
t <sub>WHDX</sub>	Write Enable High to Input Transition	5		5		ns
t <sub>EHDX</sub>	Chip Enable High to Input Transition	10		15		ns
t <sub>WLQZ</sub> <sup>(1, 2)</sup>	Write Enable Low to Output Hi-Z		25		30	ns
t <sub>AVWH</sub>	Address Valid to Write Enable High	60		70		ns
t <sub>AVEH</sub>	Address Valid to Chip Enable High	60		70		ns
t <sub>WHQX</sub> <sup>(1, 2)</sup>	Write Enable High to Output Transition	5		5		ns

 Note: 1. C<sub>L</sub> = 5pF.

 2. If  $\overline{E}$  goes low simultaneously with  $\overline{W}$  going low, the outputs remain in the high impedance state.

If the processor does not reset the timer within the specified period, the M48T513Y/V sets the WDF (Watchdog Flag) and generates a watchdog interrupt or a microprocessor reset. WDF is reset by reading the Flags Register (Address 7FFF0h). The most significant bit of the Watchdog Register is the Watchdog Steering Bit (WDS). When set to a '0', the watchdog will activate the  $\overline{IRQ/FT}$  pin when timed-out. When WDS is set to a '1', the watchdog will output a negative pulse on the RST pin for 40 to 200 ms. The Watchdog register and the FT bit will reset to a '0' at the end of a Watchdog time-out when the WDS bit is set to a '1'. The watchdog timer can be reset by two methods: 1) a transition (high-to-low or low-to-high) can be applied to the Watchdog Input pin (WDI) or 2) the microprocessor can perform a write of the Watchdog Register. The time-out period then starts over. The WDI pin should be tied to V<sub>SS</sub> if not used. The watchdog will be reset on each transition (edge) seen by the WDI pin. In the order to perform a software reset of the watchdog timer, the original time-out period can be written into the Watchdog Register, effectively restarting the count-down cycle.

Should the watchdog timer time-out, and the WDS bit is programmed to output an interrupt, a value of 00h needs to be written to the Watchdog Register in order to clear the  $\overline{IRQ/FT}$  pin. This will also disable the watchdog function until it is again programmed correctly. A read of the Flags Register will reset the Watchdog Flag (Bit D7; Register 7FFF0h).

The watchdog function is automatically disabled upon power-down and the Watchdog Register is cleared. If the watchdog function is set to output to the  $\overline{IRQ/FT}$  pin and the frequency test function is activated, the watchdog or alarm function prevails and the frequency test function is denied.

#### POWER-ON RESET

The M48T513Y/V continuously monitors V<sub>CC</sub>. When V<sub>CC</sub> falls to the power fail detect trip point, the RST pulls low (open drain) and remains low on power-up for 40 to 200ms after V<sub>CC</sub> passes V<sub>PPFD</sub>. The RST pin is an open drain output and an appropriate pull-up resistor to V<sub>CC</sub> should be chosen to control the rise time.

Figure 8. Chip Enable or Output Enable Controlled, Read Mode AC Waveforms

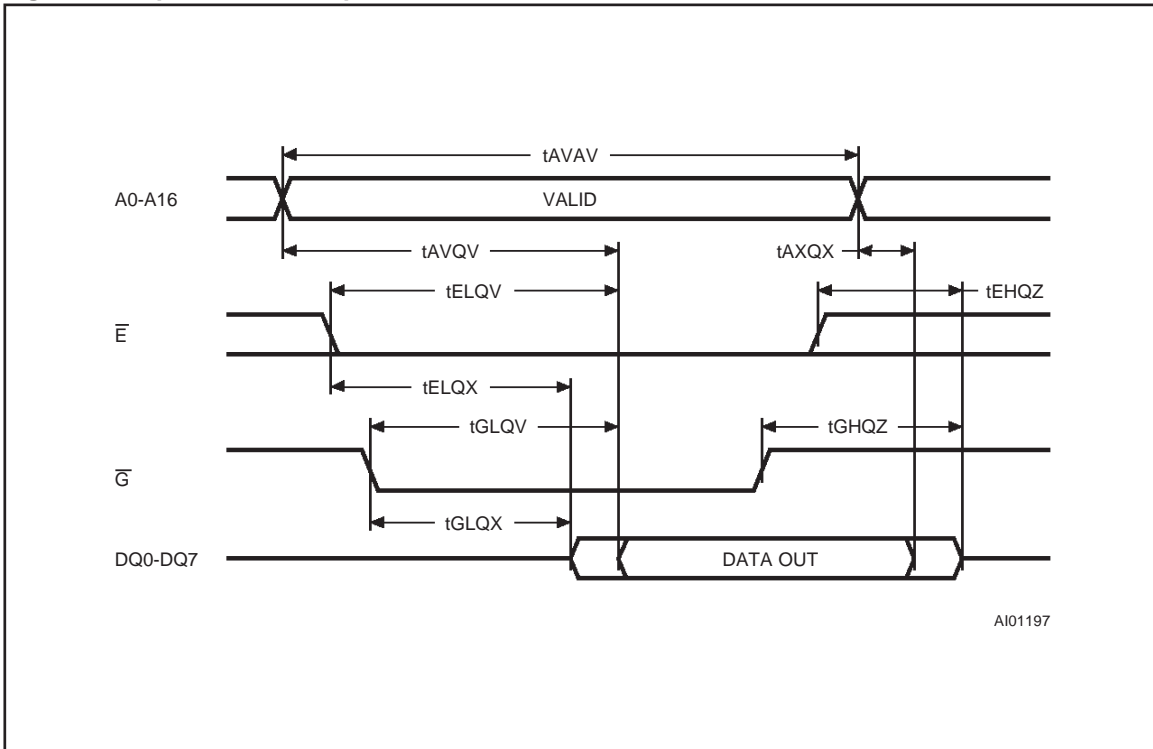

Figure 9. Write Enable Controlled, Write AC Waveforms

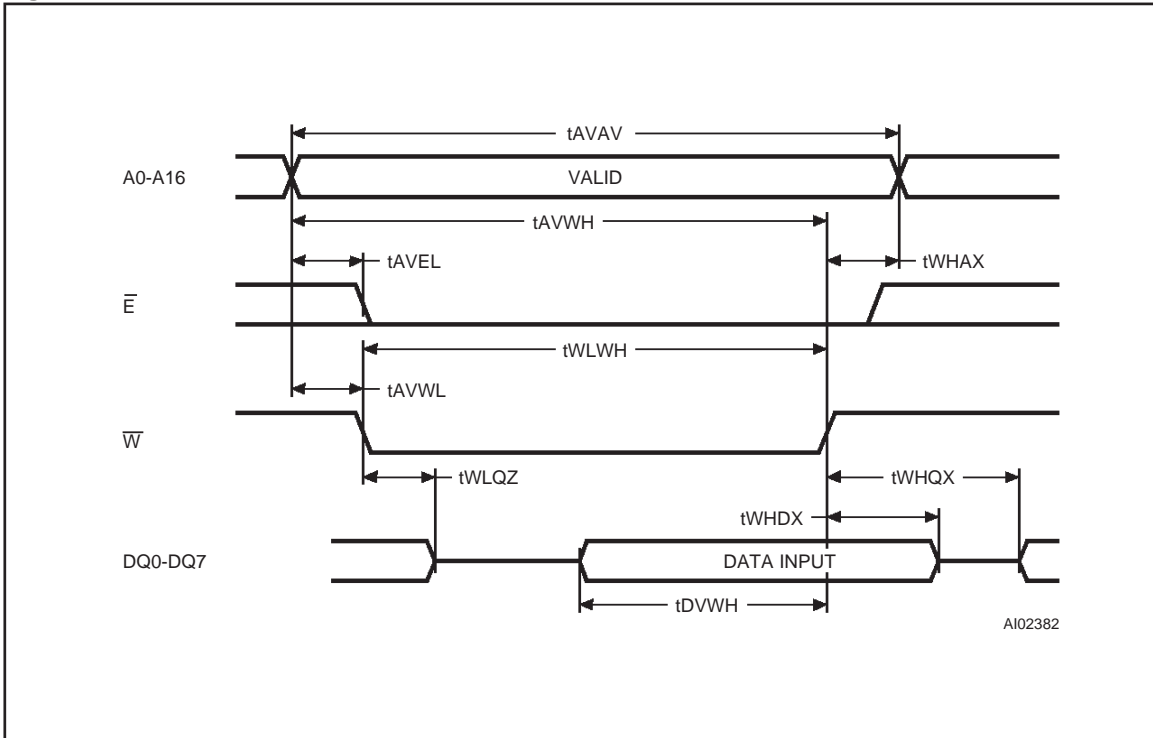
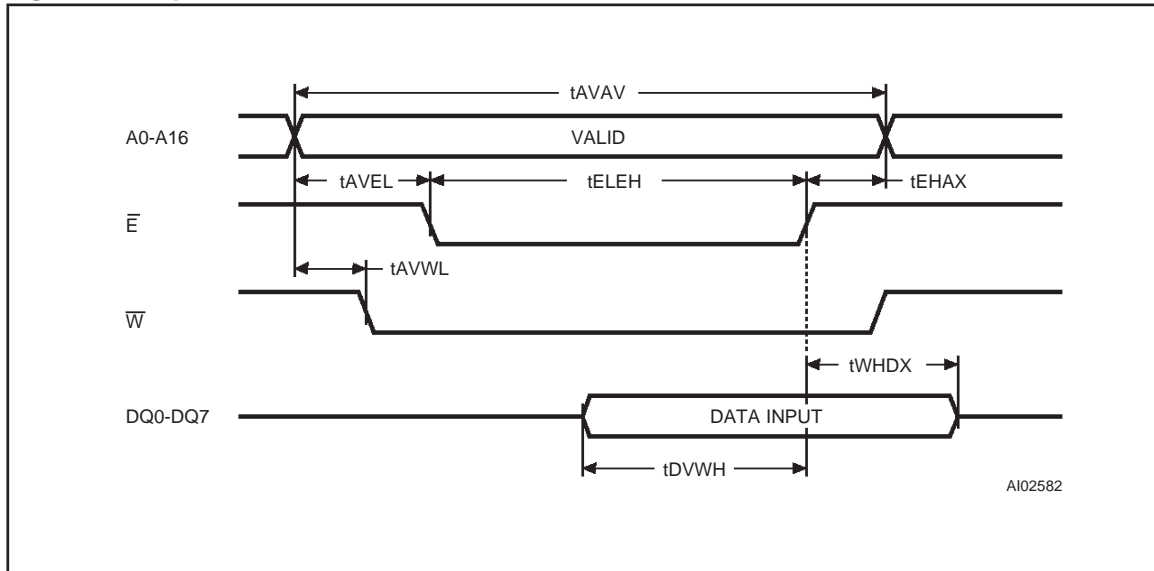

Figure 10. Chip Enable Controlled, Write AC Waveforms



### RESET INPUT ( $\overline{\text{RSTIN}}$ )

The M48T513Y/V provides an independent input which can generate an output reset. The duration and function of this reset is identical to a reset generated by a power cycle. Table 13 and Figure 14 illustrate the AC reset characteristics of this function. Pulses shorter than  $t_R$  will not generate a reset condition.  $\overline{\text{RSTIN}}$  is internally pulled up to  $V_{CC}$  through a 100K $\Omega$  resistor.

### CALIBRATING THE CLOCK

The M48T513Y/V is driven by a quartz controlled oscillator with a nominal frequency of 32,768Hz. The devices are factory calibrated at 25°C and tested for accuracy. Clock accuracy will not exceed 35 ppm (parts per million) oscillator frequency error at 25°C, which equates to about \* 1.53 minutes per month. When the Calibration circuit is properly employed, accuracy improves to better than 4 ppm at 25°C. The oscillation rate of crystals changes with temperature. The M48T513Y/V design employs periodic counter correction. The calibration circuit adds or subtracts counts from the oscillator divider circuit at the divide by 256 stage, as shown in Figure 11.

The number of times pulses which are blanked (subtracted, negative calibration) or split (added, positive calibration) depends upon the value loaded into the five Calibration bits found in the Control Register. Adding counts speeds the clock up, subtracting counts slows the clock down. The Calibration bits occupy the five lower order bits (D4-D0) in

the Control Register 7FFF8h. These bits can be set to represent any value between 0 and 31 in binary form. Bit D5 is a Sign bit; '1' indicates positive calibration, '0' indicates negative calibration. Calibration occurs within a 64 minute cycle. The first 62 minutes in the cycle may, once per minute, have one second either shortened by 128 or lengthened by 256 oscillator cycles.

If a binary '1' is loaded into the register, only the first 2 minutes in the 64 minute cycle will be modified; if a binary 6 is loaded, the first 12 will be affected, and so on. Therefore, each calibration step has the effect of adding 512 or subtracting 256 oscillator cycles for every 125, 829, 120 actual oscillator cycles, that is +4.068 or -2.034 ppm of adjustment per calibration step in the calibration register. Assuming that the oscillator is running at exactly 32,768Hz, each of the 31 increments in the Calibration byte would represent +10.7 or -5.35 seconds per month which corresponds to a total range of +5.5 or -2.75 minutes per month. Figure 11 illustrates a TIMEKEEPER calibration waveform.

Two methods are available for ascertaining how much calibration a given M48T513Y/V may require. The first involves setting the clock, letting it run for a month and comparing it to a known accurate reference and recording deviation over a fixed period of time.

Calibration values, including the number of seconds lost or gained in a given period, can be found in Application Note: TIMEKEEPER CALIBRATION.

Table 11. TIMEKEEPER Register Map

Address	Data								Function/Range BCD Format	
	D7	D6	D5	D4	D3	D2	D1	D0		
7FFFFh	10 Years				Year				Year	00-99
7FFFEh	0	0	0	10 M	Month				Month	01-12
7FFFDh	0	0	10 Date		Date				Date	01-31
7FFFCh	0	FT	0	0	0	Day of Week			Day	01-07
7FFF Bh	0	0	10 Hours		Hours (24 Hour Format)				Hour	00-23
7FFFAh	0	10 Minutes			Minutes				Minutes	00-59
7FFF9h	ST	10 Seconds			Seconds				Seconds	00-59
7FFF8h	W	R	S	Calibration					Control	
7FFF7h	WDS	BMB4	BMB3	BMB2	BMB1	BMB0	RB1	RB0	Watchdog	
7FFF6h	AFE	0	ABE	AI 10M	Alarm Month				A Month	01-12
7FFF5h	RPT4	RPT5	AI 10 Date		Alarm Date				AI Date	01-31
7FFF4h	RPT3	0	AI 10 Hours		Alarm Hours				A Hours	00-23
7FFF3h	RPT2	AI 10 Minutes			Alarm Minutes				A Min	00-59
7FFF2h	RPT1	AI 10 Seconds			Alarm Seconds				A Sec	00-59
7FFF1h	1000 Year				100 Year				Century	00-99
7FFF0h	WDF	AF	0	BL	Y	Y	Y	Y	Flag	

Keys: S = SIGN Bit  
 FT = FREQUENCY TEST Bit  
 R = READ Bit  
 W = WRITE Bit  
 ST = STOP Bit  
 0 = Must be set to '0'  
 Y = '1' or '0'  
 BL = Battery Low

AF = Alarm Flag  
 WDS = Watchdog Steering Bit  
 BMB0-BMB4 = Watchdog Multiplier Bits  
 RB0-RB1 = Watchdog Resolution Bits  
 AFE = Alarm Flag Enable  
 ABE = Alarm in Battery Back-up Mode Enable  
 RPT1-RPT5 = Alarm Repeat Mode Bits  
 WDF = Watchdog Flag

Figure 11. Calibration Waveform

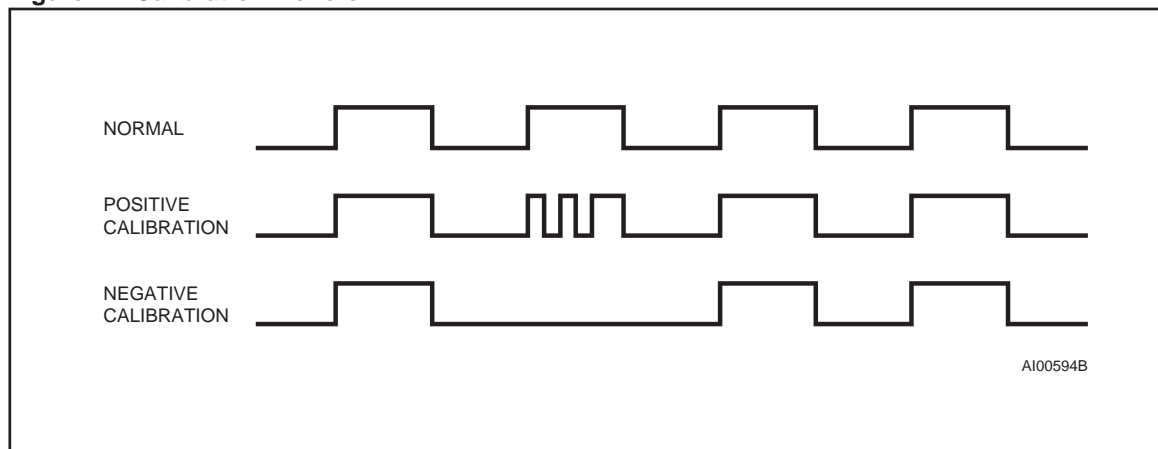

Figure 12. Alarm Interrupt Reset Waveform

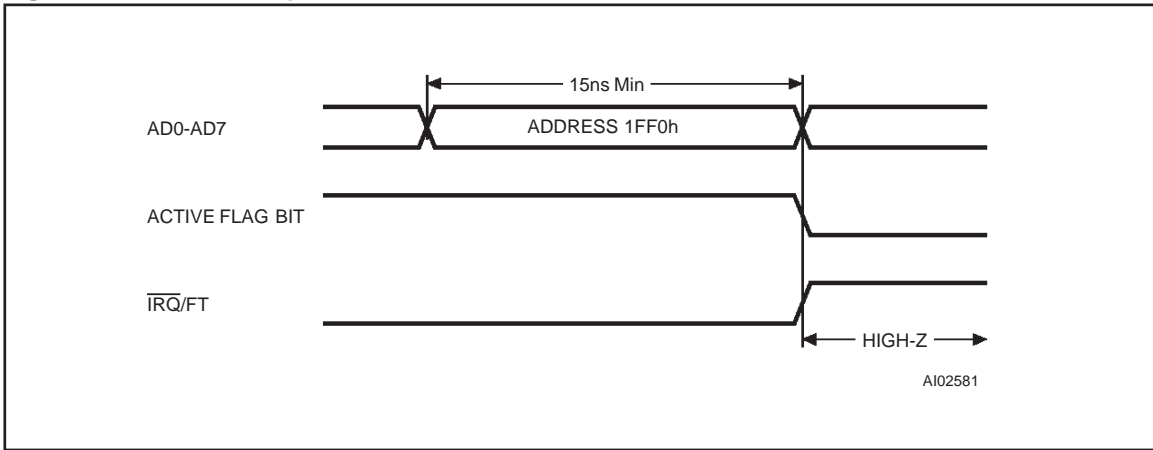

Figure 13. Back-up Mode Alarm Waveforms

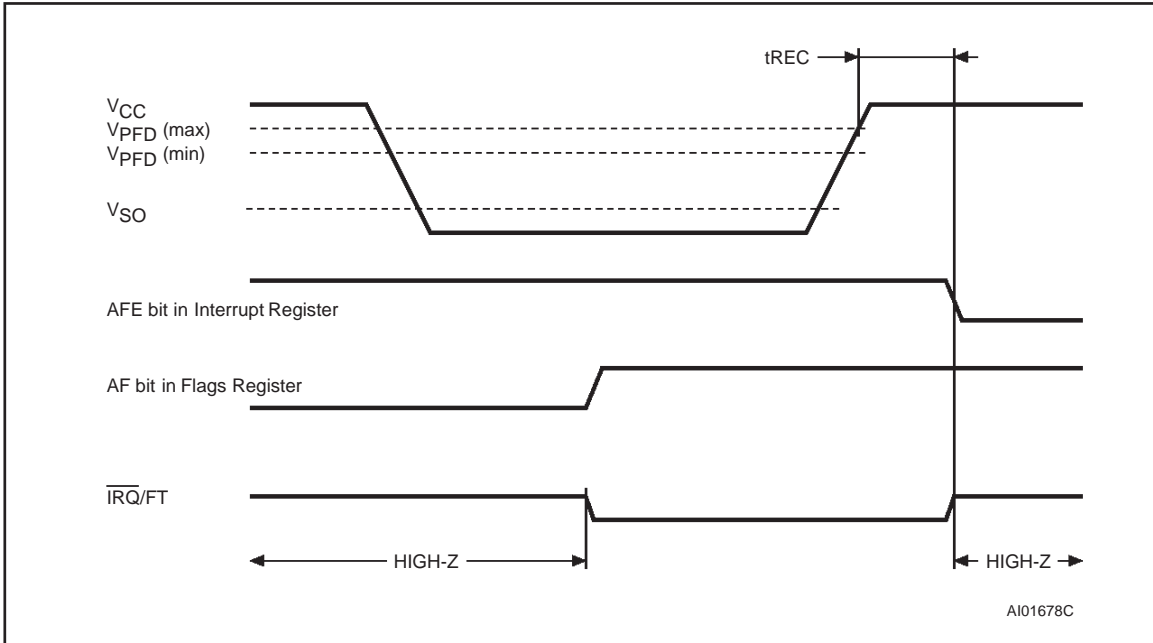

Table 12. Alarm Repeat Mode

RPT4	RPT3	RPT2	RPT1	Alarm Activated
1	1	1	1	Once per Second
1	1	1	0	Once per Minute
1	1	0	0	Once per Hour
1	0	0	0	Once per Day
1	0	0	0	Once per Month

This allows the designer to give the end user the ability to calibrate the clock as the environment requires, even if the final product is packaged in a non-user serviceable enclosure. The designer could provide a simple utility that accesses the Calibration byte.

The second approach is better suited to a manufacturing environment, and involves the use of the  $\overline{\text{IRQ}}/\text{FT}$  pin. The pin will toggle at 512Hz, when the Stop bit (ST, D7 of 7FFF9h) is '0', the Frequency Test bit (FT, D6 of 7FFFCh) is '1', the Alarm Flag Enable bit (AFE, D7 of 7FFF6h) is '0', and the Watchdog Steering bit (WDS, D7 of 7FFF7h) is '1' or the Watchdog Register (7FFF7h = 0) is reset.

**Note:** A 4 second settling time must be allowed before reading the 512Hz output.

Any deviation from 512Hz indicates the degree and direction of oscillator frequency shift at the test temperature. For example, a reading of 512.010124Hz would indicate a +20 ppm oscillator frequency error, requiring a -10 (WR001010) to be loaded into the Calibration Byte for correction. Note that setting or changing the Calibration Byte does not affect the Frequency test output frequency.

The  $\overline{\text{IRQ}}/\text{FT}$  pin is an open drain output which requires a pull-up resistor for proper operation. A 500-10k $\Omega$  resistor is recommended in order to control the rise time. The FT bit is cleared on power-up.

### BATTERY LOW WARNING

The M48T513Y/V automatically performs battery voltage monitoring upon power-up and at factory-programmed time intervals of approximately 24 hours. The Battery Low (BL) bit, Bit D4 of Flags Register 7FFF0h, will be asserted if the battery voltage is found to be less than approximately 2.5V.

If a battery low is generated during a power-up sequence, this indicates that the battery is below approximately 2.5 volts and may not be able to maintain data integrity in the SRAM. Data should be considered suspect and verified as correct.

If a battery low indication is generated during the 24-hour interval check, this indicates that the battery is near end of life. However, data is not compromised due to the fact that a nominal  $V_{CC}$  is supplied.

The M48T513Y/V only monitors the battery when a nominal  $V_{CC}$  is applied to the device. Thus applications which require extensive durations in the battery back-up mode should be powered-up periodically (at least once every few months) in order for this technique to be beneficial. Additionally, if a battery low is indicated, data integrity should be verified upon power-up via a checksum or other technique.

### POWER-ON DEFAULTS

Upon application of power to the device, the following register bits are set to a '0' state: WDS, BMB0-BMB4, RB0, RB1, AFE, ABE, W, R and FT.

Figure 14.  $\overline{\text{RSTIN}}$  Timing Waveform

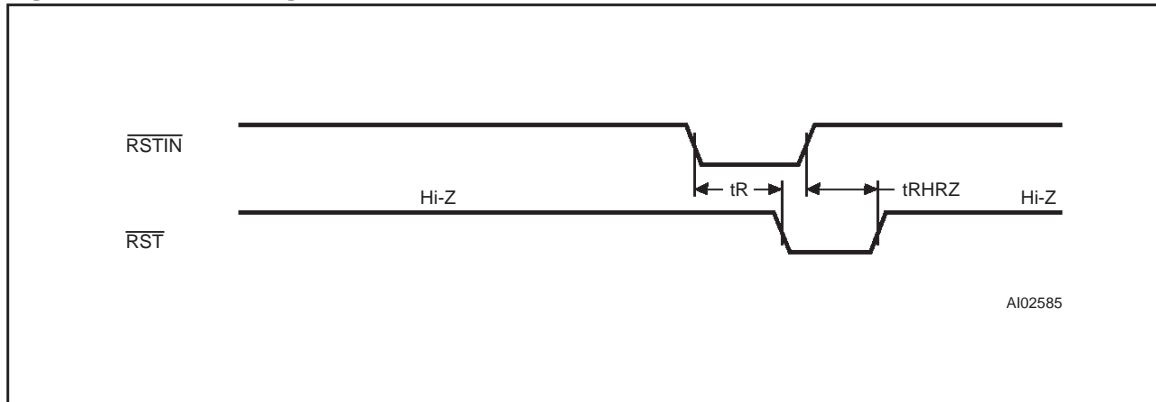
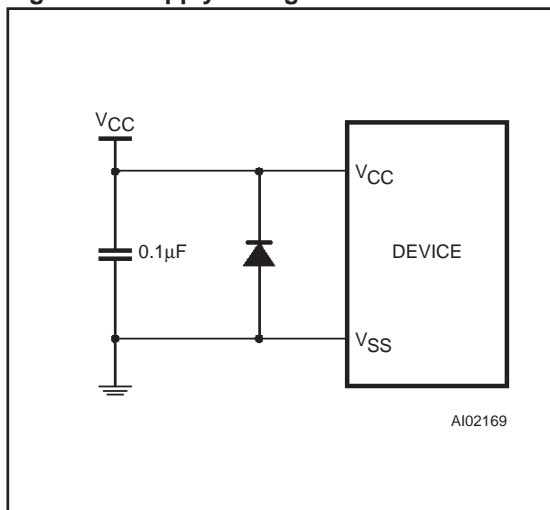

Table 13. Reset AC Characteristics  
( $T_A = 0$  to  $70$  °C,  $V_{CC} = 3.0\text{V}$  to  $3.6\text{V}$  or  $V_{CC} = 4.5\text{V}$  to  $5.5\text{V}$ )

Symbol	Parameter	Min	Max	Unit
$t_R$	$\overline{\text{RSTIN}}$ Low to $\overline{\text{RST}}$ Low	20	100	ms
$t_{\text{RHRZ}}^{(1)}$	$\overline{\text{RSTIN}}$ High to $\overline{\text{RST}}$ Hi-Z	40	200	ms

Note: 1.  $C_L = 5\text{pF}$  (see Figure 5)

Figure 15. Supply Voltage Protection



**POWER SUPPLY DECOUPLING and UNDERSHOOT PROTECTION**

$I_{CC}$  transients, including those produced by output switching, can produce voltage fluctuations, resulting in spikes on the  $V_{CC}$  bus. These transients can be reduced if capacitors are used to store energy, which stabilizes the  $V_{CC}$  bus. The energy stored in the bypass capacitors will be released as low going spikes are generated or energy will be absorbed when overshoots occur. A ceramic bypass capacitor value of  $0.1\mu\text{F}$  (see Figure 15) is recommended in order to provide the needed filtering. In addition to transients that are caused by normal SRAM operation, power cycling can generate negative voltage spikes on  $V_{CC}$  that drive it to values below  $V_{SS}$  by as much as one volt. These negative spikes can cause data corruption in the SRAM while in battery backup mode. To protect from these voltage spikes, ST recommends connecting a schottky diode from  $V_{CC}$  to  $V_{SS}$  (cathode connected to  $V_{CC}$ , anode to  $V_{SS}$ ). (Schottky diode 1N5817 is recommended for through hole and MBRS120T3 is recommended for surface mount).



**Table 14. Ordering Information Scheme**

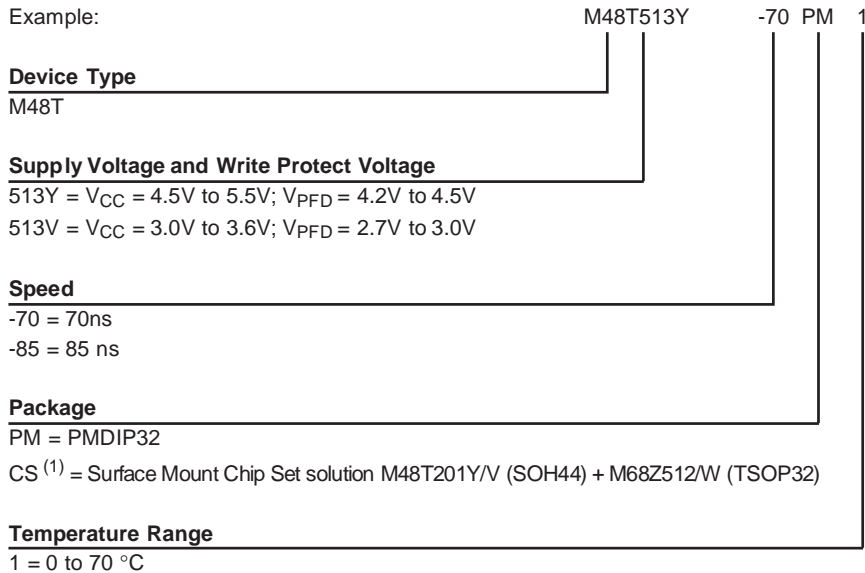

Note: 1. The SOIC package (SOH44) requires the battery package (SNAPHAT) which is ordered separately under the part number "M4Txx-BR12SH1" in plastic tube or "M4Txx-BR12SH1TR" in Tape & Reel form.

**Caution:** Do not place the SNAPHAT battery package "M4Txx-BR12SH1" in conductive foam since this will drain the lithium button-cell battery.

For a list of available options (Speed, Package, etc...) or for further information on any aspect of this device, please contact the ST Sales Office nearest to you.

**Table 15. Revision History**

Date	Revision Details
April 2000	Chipset datasheet First Issue
06/20/00	From Preliminary Data to data Sheet

**M48T513Y, M48T513V**

**Table 16. PMDIP32 - 32 pin Plastic Module DIP, Package Mechanical Data**

Symb	mm			inches		
	Typ	Min	Max	Typ	Min	Max
A		9.27	9.52		0.365	0.375
A1		0.38	–		0.015	–
B		0.43	0.59		0.017	0.023
C		0.20	0.33		0.008	0.013
D		42.42	43.18		1.670	1.700
E		18.03	18.80		0.710	0.740
e1		2.29	2.79		0.090	0.110
e3		34.29	41.91		1.350	1.650
eA		14.99	16.00		0.590	0.630
L		3.05	3.81		0.120	0.150
S		1.91	2.79		0.075	0.110
N		32			32	

**Figure 16. PMDIP32 - 32 pin Plastic Module DIP, Package Outline**

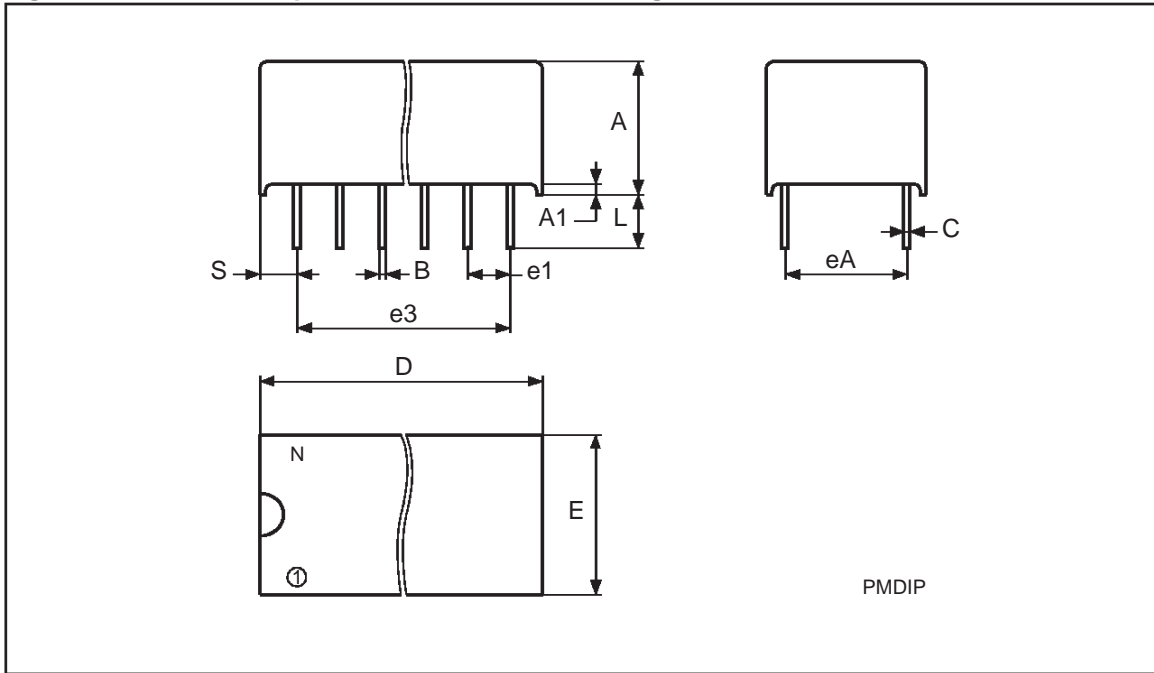

Drawing is not to scale.

Table 17. TSOP II 32 - 32 lead Plastic Thin Small Outline II, 10 x 20 mm, Package Mechanical Data

Symbol	mm			inch		
	Typ	Min	Max	Typ	Min	Max
A			1.20			0.047
A1		0.05	0.15		0.002	0.006
A2		0.95	1.05		0.037	0.041
b		0.30	0.52		0.012	0.020
C		0.12	0.21		0.005	0.008
CP			0.10			0.004
D		20.82	21.08		0.820	0.830
e	1.27	–	–	0.050	–	–
E		11.56	11.96		0.455	0.471
E1		10.03	10.29		0.395	0.405
L		0.40	0.60		0.016	0.024
$\alpha$		0°	5°		0°	5°
N		32			32	

Figure 17. TSOP II 32 - 32 lead Plastic Thin Small Outline II, 10 x 20 mm, Package Outline

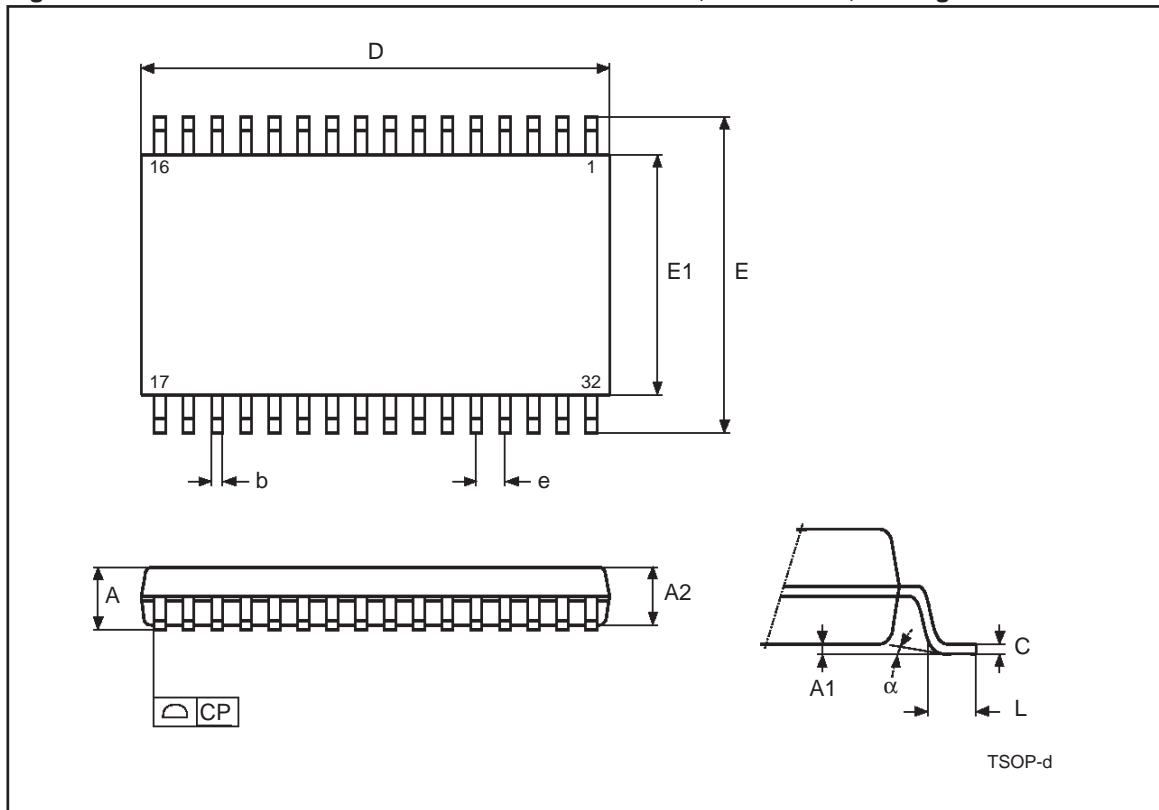

**M48T513Y, M48T513V**

**Table 18. SH - 4-pin SNAPHAT Housing for 48 mAh Battery & Crystal, Package Mechanical Data**

Symb	mm			inches		
	Typ	Min	Max	Typ	Min	Max
A			9.78			0.385
A1		6.73	7.24		0.265	0.285
A2		6.48	6.99		0.255	0.275
A3			0.38			0.015
B		0.46	0.56		0.018	0.022
D		21.21	21.84		0.835	0.860
E		14.22	14.99		0.560	0.590
eA		15.55	15.95		0.612	0.628
eB		3.20	3.61		0.126	0.142
L		2.03	2.29		0.080	0.090

**Figure 18. SH - 4-pin SNAPHAT Housing for 48 mAh Battery & Crystal, Package Outline**

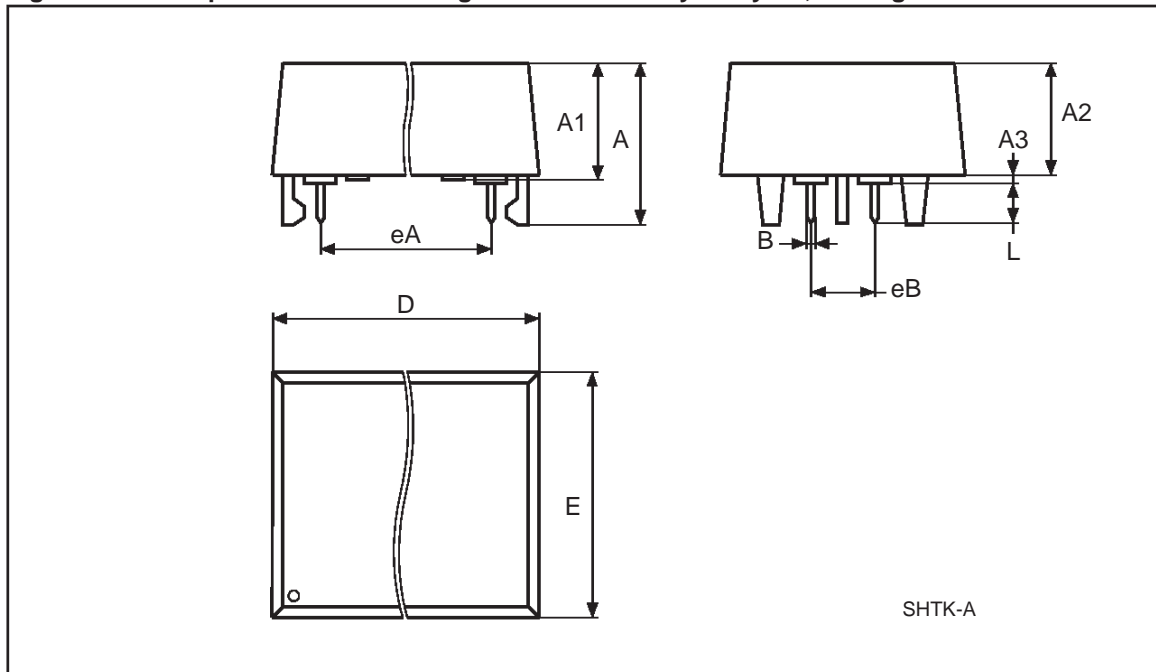

Drawing is not to scale.

Table 19. SH - 4-pin SNAPHAT Housing for 120 mAh Battery &amp; Crystal, Package Mechanical Data

Symb	mm			inches		
	Typ	Min	Max	Typ	Min	Max
A			10.54			0.415
A1		8.00	8.51		0.315	.0335
A2		7.24	8.00		0.285	0.315
A3			0.38			0.015
B		0.46	0.56		0.018	0.022
D		21.21	21.84		0.835	0.860
E		17.27	18.03		0.680	.0710
eA		15.55	15.95		0.612	0.628
eB		3.20	3.61		0.126	0.142
L		2.03	2.29		0.080	0.090

Figure 19. SH - 4-pin SNAPHAT Housing for 120 mAh Battery &amp; Crystal, Package Outline

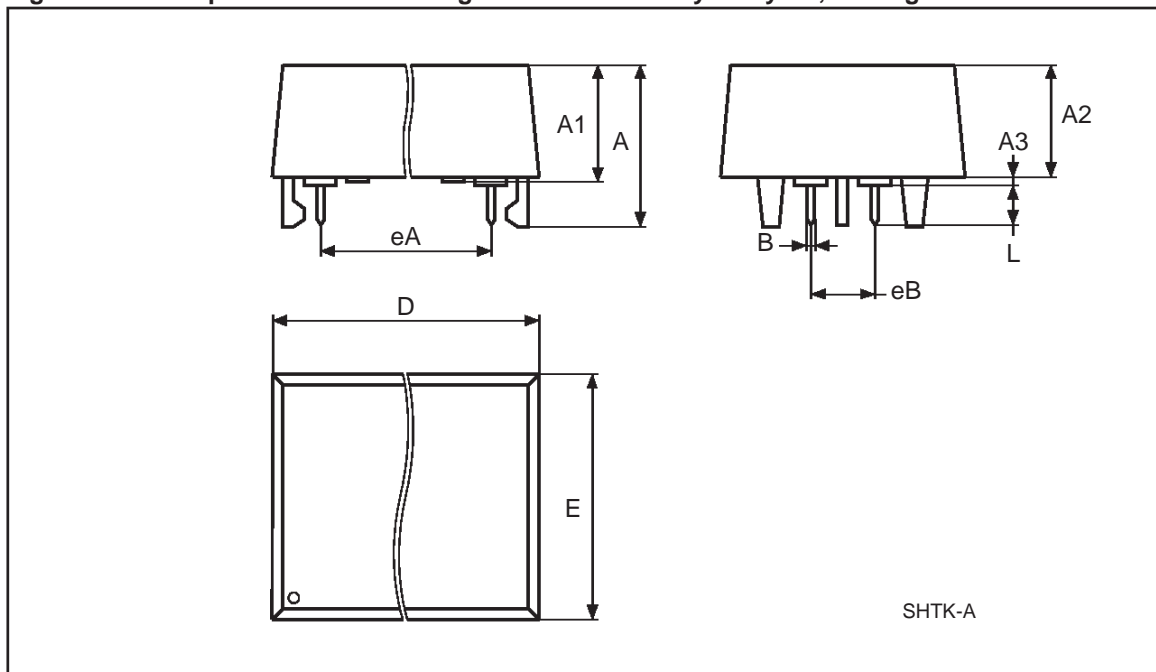

Drawing is not to scale.

M48T513Y, M48T513V

Table 20. SOH44 - 44 lead Plastic Small Outline, 4-socket battery, SNAPHAT, Package Mechanical Data

Symb	mm			inches		
	Typ	Min	Max	Typ	Min	Max
A			3.05			0.120
A1		0.05	0.36		0.002	0.014
A2		2.34	2.69		0.092	0.106
B		0.36	0.46		0.014	0.018
C		0.15	0.32		0.006	0.012
D		17.71	18.49		0.697	0.728
E		8.23	8.89		0.324	0.350
e	0.81	-	-	0.032	-	-
eB		3.20	3.61		0.126	0.142
H		11.51	12.70		0.453	0.500
L		0.41	1.27		0.016	0.050
$\alpha$		0°	8°		0°	8°
N	44			44		
CP			0.10			0.004

Figure 20. SOH44 - 44 lead Plastic Small Outline, 4-socket battery, SNAPHAT, Package Outline

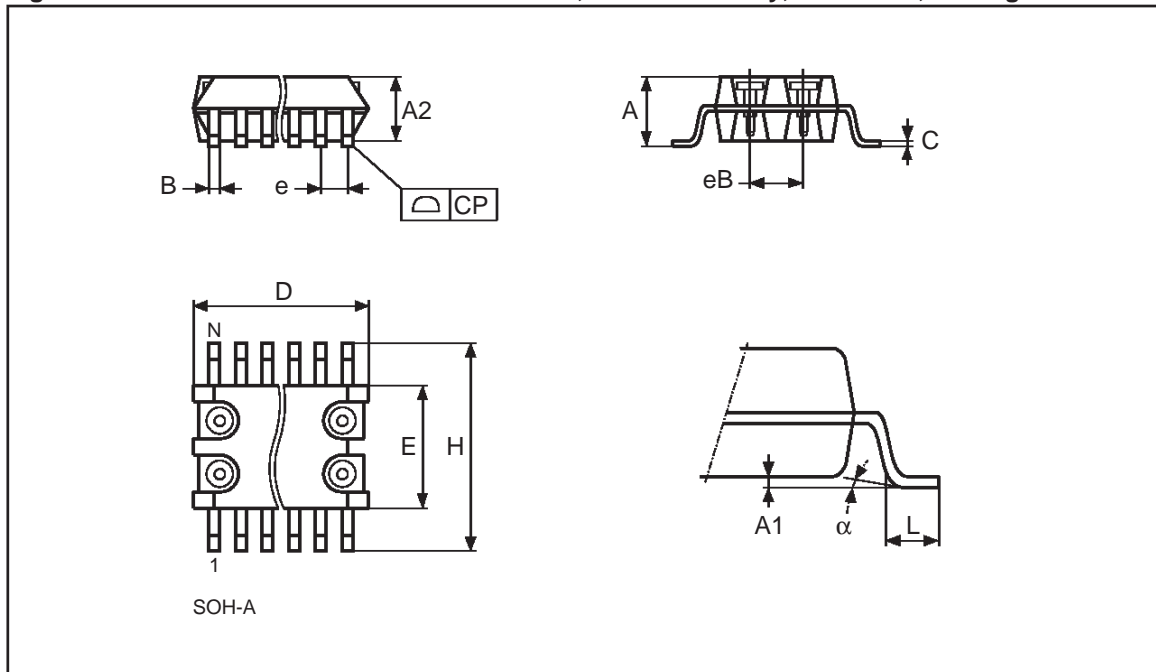

Drawing is not to scale.

Information furnished is believed to be accurate and reliable. However, STMicroelectronics assumes no responsibility for the consequences of use of such information nor for any infringement of patents or other rights of third parties which may result from its use. No license is granted by implication or otherwise under any patent or patent rights of STMicroelectronics. Specifications mentioned in this publication are subject to change without notice. This publication supersedes and replaces all information previously supplied. STMicroelectronics products are not authorized for use as critical components in life support devices or systems without express written approval of STMicroelectronics.

The ST logo is registered trademark of STMicroelectronics  
® 2000 STMicroelectronics - All Rights Reserved

All other names are the property of their respective owners.

STMicroelectronics GROUP OF COMPANIES  
Australia - Brazil - China - Finland - France - Germany - Hong Kong - India - Italy - Japan - Malaysia - Malta - Morocco -  
Singapore - Spain - Sweden - Switzerland - United Kingdom - U.S.A.

<http://www.st.com>

