

DATA SHEET

PCX8582X-2 Family 256 x 8-bit CMOS EEPROMS with I²C-bus interface

Product specification
Supersedes data of February 1992
File under Integrated Circuits, IC12

December 1994

Philips Semiconductors



PHILIPS

256 x 8-bit CMOS EEPROMS with I²C-bus interface

PCX8582X-2 Family

FEATURES

- Low power CMOS
 - maximum active current 2.0 mA
 - maximum standby current 10 μ A (at 6.0 V), typical 4 μ A
- Non-volatile storage of 2-Kbits organized as 256 \times 8-bits
- Single supply with full operation down to 2.5 V
- On-chip voltage multiplier
- Serial input/output I²C-bus
- Write operations
 - byte write mode
 - 8-byte page write mode (minimizes total write time per byte)
- Read operations
 - sequential read
 - random read
- Internal timer for writing (no external components)
- Power-on reset
- High reliability by using a redundant storage code
- Endurance
 - >500 k E/W-cycles at T_{amb} = 22 °C
- 40 years non-volatile data retention time (typ.)
- Pin and address compatible to
 - PCX8570, PCF8571, PCF8572 and PCF8581
 - PCX8494X-2, PCX8598X-2 -Family.



DESCRIPTION

The PCX8582X-2 is a 2-Kbit (256 \times 8-bit) floating gate electrically erasable programmable read only memory (EEPROM). By using an internal redundant storage code it is fault tolerant to single bit errors. This feature dramatically increases reliability compared to conventional EEPROM memories.

Power consumption is low due to the full CMOS technology used. The programming voltage is generated on-chip, using a voltage multiplier.

As data bytes are received and transmitted via the serial I²C-bus, a package using eight pins is sufficient. Up to eight PCX8582X-2 devices may be connected to the I²C-bus. Chip select is accomplished by three address inputs (A0, A1, A2).

Timing of the ERASE/WRITE cycle is carried out internally, thus no external components are required. Pin 7 (PTC) must be connected to either V_{DD} or left open-circuit.

There is an option of using an external clock for timing the length of an ERASE/WRITE cycle.

QUICK REFERENCE DATA

SYMBOL	PARAMETER	CONDITIONS	MIN.	MAX.	UNIT
V _{DD}	supply voltage		2.5	6.0	V
I _{DDR}	supply current READ	f _{SCL} = 100 kHz V _{DD} = 3 V V _{DD} = 6 V	–	60 200	μ A μ A
I _{DDW}	supply current ERASE/WRITE	f _{SCL} = 100 kHz V _{DD} = 3 V V _{DD} = 6 V	–	0.6 2.0	mA mA
I _{DDSB}	supply current STANDBY	V _{DD} = 3 V V _{DD} = 6 V	–	3.5 10	μ A μ A

256 x 8-bit CMOS EEPROMS
with I²C-bus interface

PCX8582X-2 Family

ORDERING INFORMATION

TYPE NUMBER	PACKAGE			TEMPERATURE (°C)		SUPPLY (V)	
	NAME	DESCRIPTION	VERSION	MIN.	MAX.	MIN.	MAX.
PCF8582C-2P	DIP8	plastic dual in-line package; 8 leads (300 mil)	SOT97-1	-40	+85	2.5	6.0
PCD8582D-2P				-25	+70	3.0	6.0
PCF8582E-2P				-40	+85	4.5	5.5
PCA8582F-2P				-40	+125	4.5	5.5
PCF8582C-2T	SO8	plastic small outline package; 8 leads; body width 3.9 mm	SOT96-1	-40	+85	2.5	6.0
PCD8582D-2T				-25	+70	3.0	6.0
PCF8582E-2T				-40	+85	4.5	5.5
PCA8582F-2T				-40	+125	4.5	5.5

DEVICE SELECTION

Table 1 Device selection code

SELECTION	DEVICE CODE				CHIP ENABLE			R/W
Bit	b7	b6	b5	b4	b3	b2	b1	b0
Device	1	0	1	0	A2	A1	A0	R/W

Note

- The MSB b7 is sent first.

Table 2 Endurance and data retention guarantees

DEVICE	ENDURANCE E/W CYCLES	DATA RETENTION YEARS
PCF8582C-2; PCA8582F-2	500000 ⁽¹⁾	40

Note

- At the time of publication of this data sheet the statistical history was not yet sufficient to guarantee 100000000 E/W cycle performance for these types.

256 x 8-bit CMOS EEPROMS
with I²C-bus interface

PCX8582X-2 Family

BLOCK DIAGRAM

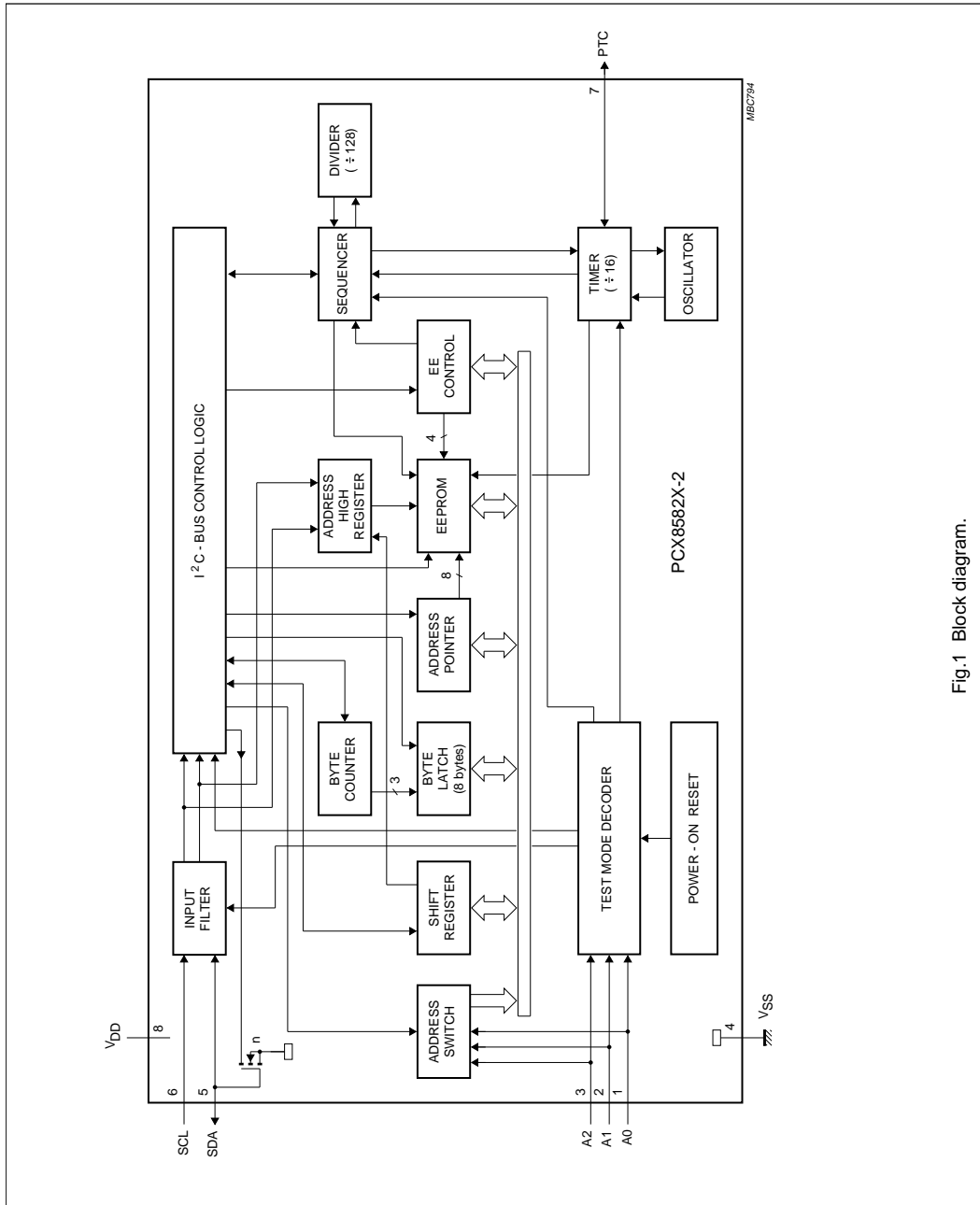

Fig.1 Block diagram.

256 x 8-bit CMOS EEPROMS with I²C-bus interface

PCX8582X-2 Family

PINNING

SYMBOL	PIN	DESCRIPTION
A0	1	address input 0
A1	2	address input 1
A2	3	address input 2
V _{SS}	4	negative supply voltage
SDA	5	serial data input/output (I ² C-bus)
SCL	6	serial clock input (I ² C-bus)
PTC	7	programming time control output
V _{DD}	8	positive supply voltage

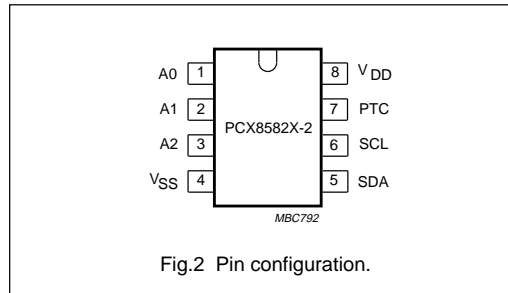

LIMITING VALUES

In accordance with the Absolute Maximum Rating System (IEC134).

SYMBOL	PARAMETER	CONDITIONS	MIN.	MAX.	UNIT
V _{DD}	supply voltage		-0.3	+7.0	V
V _I	voltage on any input pin	Z _I > 500 Ω	V _{SS} - 0.8	V _{DD} + 0.8	V
I _I	current on any input pin		-	1	mA
I _O	output current		-	10	mA
T _{stg}	storage temperature		-65	+150	°C
T _{amb}	operating ambient temperature				
	PCF8582C-2; PCF8582E-2		-40	+85	°C
	PCD8582D-2		-25	+70	°C
	PCA8582F-2		-40	+125	°C

256 x 8-bit CMOS EEPROMS with I²C-bus interface

PCX8582X-2 Family

CHARACTERISTICS

PCF8582C-2: $V_{DD} = 2.5$ to 6.0 V; $V_{SS} = 0$ V; $T_{amb} = -40$ to $+85$ °C; unless otherwise specified.

PCD8582D-2: $V_{DD} = 3.0$ to 6.0 V; $V_{SS} = 0$ V; $T_{amb} = -25$ to $+70$ °C; unless otherwise specified.

PCF8582E-2: $V_{DD} = 4.5$ to 5.5 V; $V_{SS} = 0$ V; $T_{amb} = -40$ to $+85$ °C; unless otherwise specified.

PCA8582F-2: $V_{DD} = 4.5$ to 5.5 V; $V_{SS} = 0$ V; $T_{amb} = -40$ to $+125$ °C; unless otherwise specified.

SYMBOL	PARAMETER	CONDITIONS	MIN.	MAX.	UNIT
Supplies					
V_{DD}	supply voltage				
	PCF8582C-2		2.5	6.0	V
	PCD8582D-2		3.0	6.0	V
	PCF8582E-2; PCA8582F-2		4.5	5.5	V
I_{DDR}	supply current READ	$f_{SCL} = 100$ kHz			
	PCF8582C-2; PCD8582D-2	$V_{DD} = 3.0$ V	–	60	μ A
		$V_{DD} = 6.0$ V	–	200	μ A
	PCF8582E-2; PCA8582F-2	$V_{DD} = 5.5$ V	–	200	μ A
I_{DDW}	supply current ERASE/WRITE	$f_{SCL} = 100$ kHz			
	PCF8582C-2; PCD8582D-2	$V_{DD} = 3.0$ V	–	0.6	mA
		$V_{DD} = 6.0$ V	–	2.0	mA
	PCF8582E-2; PCA8582F-2	$V_{DD} = 5.5$ V	–	2.0	mA
I_{DDSB}	supply current STANDBY	$f_{SCL} = 100$ kHz			
	PCF8582C-2; PCD8582D-2	$V_{DD} = 3.0$ V	–	3.5	μ A
		$V_{DD} = 6.0$ V	–	10	μ A
	PCF8582E-2; PCA8582F-2	$V_{DD} = 5.5$ V	–	10	μ A
PTC input (pin 7)					
V_{IL}	LOW level input voltage		–0.8	$0.1V_{DD}$	V
V_{IH}	HIGH level input voltage		$0.9V_{DD}$	$V_{DD} + 0.8$	V
SCL input (pin 6)					
V_{IL}	LOW level input voltage		–0.8	$0.3V_{DD}$	V
V_{IH}	HIGH level input voltage		$0.7V_{DD}$	$V_{DD} + 0.8$	V
I_{LI}	input leakage current	$V_I = V_{DD}$ or V_{SS}	–	± 1	μ A
f_{SCL}	clock input frequency		0	100	kHz
C_I	input capacitance	$V_I = V_{SS}$	–	7	pF
SDA input/output (pin 5)					
V_{IL}	LOW level input voltage		–0.8	$0.3V_{DD}$	V
V_{IH}	HIGH level input voltage		$0.7V_{DD}$	$V_{DD} + 0.8$	V
V_{OL}	LOW level output voltage	$I_{OL} = 3$ mA; $V_{DD(min)}$	–	0.4	V
I_{LO}	output leakage current	$V_{OH} = V_{DD}$	–	1	μ A
C_I	input capacitance	$V_I = V_{SS}$	–	7	pF
Data retention time					
t_S	data retention time	$T_{amb} = 55$ °C	10	–	years

256 x 8-bit CMOS EEPROMS
with I²C-bus interface

PCX8582X-2 Family

WRITE CYCLE LIMITS

Selection of the chip address is achieved by connecting the A0, A1 and A2 inputs to either V_{SS} or V_{DD}.

SYMBOL	PARAMETER	CONDITIONS	MIN.	TYP.	MAX.	UNIT
ERASE/WRITE cycle timing						
t _{EW}	ERASE/WRITE cycle time		–	7	–	ms
	internal oscillator		4	–	10	ms
Endurance						
N _{EW}	ERASE/WRITE cycle per byte					
	PCF8582C-2	T _{amb} = 85 °C; t _{EW} = 4 to 10 ms	100 000	–	–	cycles
		T _{amb} = 22 °C; t _{EW} = 5 ms	500 000	–	–	cycles
	PCD8582D-2	T _{amb} = –25 to +70 °C; t _{EW} = 4 to 10 ms	10 000	–	–	cycles
		T _{amb} = –25 to +40 °C; t _{EW} = 5 ms	100 000	–	–	cycles
	PCF8582E-2	T _{amb} = –40 to +85 °C; t _{EW} = 4 to 10 ms	10 000	–	–	cycles
PCA8582F-2		T _{amb} = 22 °C; t _{EW} = 5 ms	100 000	–	–	cycles
		T _{amb} = 125 °C; t _{EW} = 4 to 10 ms	50 000	–	–	cycles
		T _{amb} = 85 °C; t _{EW} = 4 to 10 ms	100 000	–	–	cycles
		T _{amb} = 22 °C; t _{EW} = 5 ms	500 000	–	–	cycles

256 x 8-bit CMOS EEPROMS with I²C-bus interface

PCX8582X-2 Family

I²C-BUS PROTOCOL

The I²C-bus is for 2-way, 2-line communication between different ICs or modules. The serial bus consists of two bidirectional lines: one for data signals (SDA), and one for clock signals (SCL).

Both the SDA and SCL lines must be connected to a positive supply voltage via a pull-up resistor.

The following protocol has been defined:

- Data transfer may be initiated only when the bus is not busy.
- During data transfer, the data line must remain stable whenever the clock line is HIGH. Changes in the data line while the clock line is HIGH will be interpreted as control signals.

The following bus conditions have been defined:

- **Bus not busy:** both data and clock lines remain HIGH.
- **Start data transfer:** a change in the state of the data line, from HIGH-to-LOW, while the clock is HIGH, defines the start condition.
- **Stop data transfer:** a change in the state of the data line, from LOW-to-HIGH, while the clock is HIGH, defines the stop condition.
- **Data valid:** the state of the data line represents valid data when, after a start condition, the data line is stable for the duration of the HIGH period of the clock signal. There is one clock pulse per bit of data.

Each data transfer is initiated with a start condition and terminated with a stop condition; the number of the data bytes, transferred between the start and stop conditions is limited to seven bytes in the ERASE/WRITE mode and eight bytes in the PAGE ERASE/WRITE mode. Data transfer is unlimited in the READ mode. The information is transmitted in bytes and each receiver acknowledges with a ninth bit.

Within the I²C-bus specifications a low-speed mode (2 kHz clock rate) and a high speed mode (100 kHz clock rate) are defined.

The PCX8582X-2 operates in both modes.

By definition a device that sends a signal is called a 'transmitter', and the device which receives the signal is called a 'receive'. The device which controls the signal is called the 'master'. The devices that are controlled by the master are called 'slaves'.

Each byte is followed by one acknowledge bit. This acknowledge bit is a HIGH level, put on the bus by the transmitter. The master generates an extra acknowledge related clock pulse. The slave receiver which is addressed is obliged to generate an acknowledge after the reception of each byte.

The master receiver must generate an acknowledge after the reception of each byte that has been clocked out of the slave transmitter.

The device that acknowledges has to pull down the SDA line during the acknowledge clock pulse in such a way that the SDA line is stable LOW during the HIGH period of the acknowledge related clock pulse.

Set-up and hold times must be taken into account. A master receiver must signal an end of data to the slave transmitter by not generating an acknowledge on the last byte that has been clocked out of the slave. In this event the transmitter must leave the data line HIGH to enable the master generation of the stop condition.

DEVICE ADDRESSING

Following a start condition the bus master must output the address of the slave it is accessing. The most significant four bits of the slave address are the device type identifier (see Fig.3). For the PCX8582X-2 this is fixed as 1010.

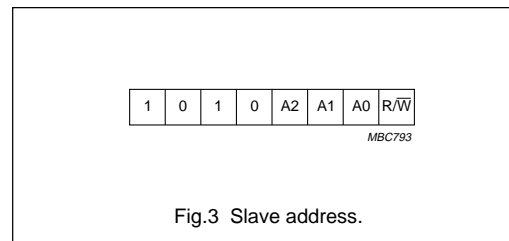

Fig.3 Slave address.

The next three significant bits address a particular device. A system could have up to eight PCX8582X-2 devices on the bus. The eight addresses are defined by the state of the A0, A1 and A2 inputs.

The last bit of the slave address defines the operation to be performed. When set to logic 1 a read operation is selected.

Address bits must be connected to either V_{DD} or V_{SS}.

**256 x 8-bit CMOS EEPROMS
with I²C-bus interface**

PCX8582X-2 Family**WRITE OPERATIONS****Byte/word write**

For a write operation the PCX8582X-2 requires a second address field. This address field is a word address providing access to the 256 words of memory. Upon receipt of the word address the PCX8582X-2 responds with an acknowledge and awaits the next eight bits of data, again responding with an acknowledge. Word address is automatically incremented. The master can now terminate the transfer by generating a stop condition or transmit up to six more bytes of data and then terminate by generating a stop condition.

After this stop condition the ERASE/WRITE cycle starts and the bus is free for another transmission. Its duration is 7 ms (typ.) per byte.

During the ERASE/WRITE cycle the slave receiver does not send an acknowledge bit if addressed via the I²C-bus.

PAGE WRITE

The PCX8582X-2 is capable of an eight-byte page write operation. It is initiated in the same manner as the byte write operation. The master can transmit eight data bytes within one transmission. After receipt of each byte the PCX8582X-2 will respond with an acknowledge. The typical ERASE/WRITE time in this mode is $9 \times 7 \text{ ms} = 63 \text{ ms}$.

After the receipt of each data byte the three low order bits of the word address are internally incremented. The high order five bits of the address remain unchanged. If the master transmits more than eight bytes prior to generating the stop condition, no acknowledge will be given on the ninth (and following) data bytes and the whole transmission will be ignored. As in the byte write operation, all inputs are disabled until completion of the internal write cycles.

256 x 8-bit CMOS EEPROMS
with I²C-bus interface

PCX8582X-2 Family

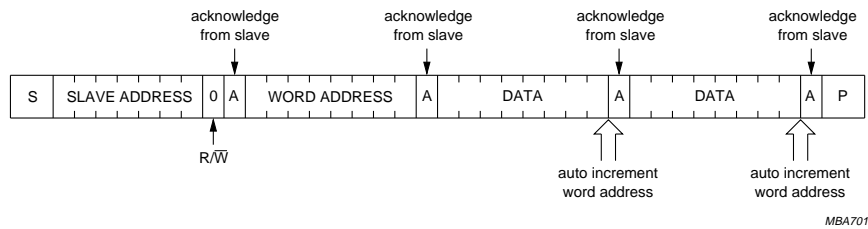

Fig.4 Auto increment memory word address; two byte write.

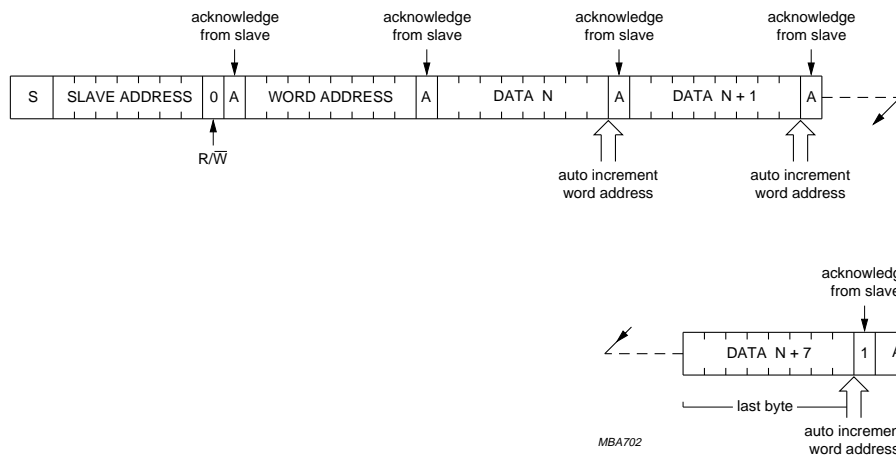

Fig.5 Page write operation; eight byte.

256 x 8-bit CMOS EEPROMS
with I²C-bus interface

PCX8582X-2 Family

READ OPERATIONS

Read operations are initiated in the same manner as write operations with the exception that the LSB of the slave address is set to logic 1. There are three basic read operations; current address read, random read and sequential read.

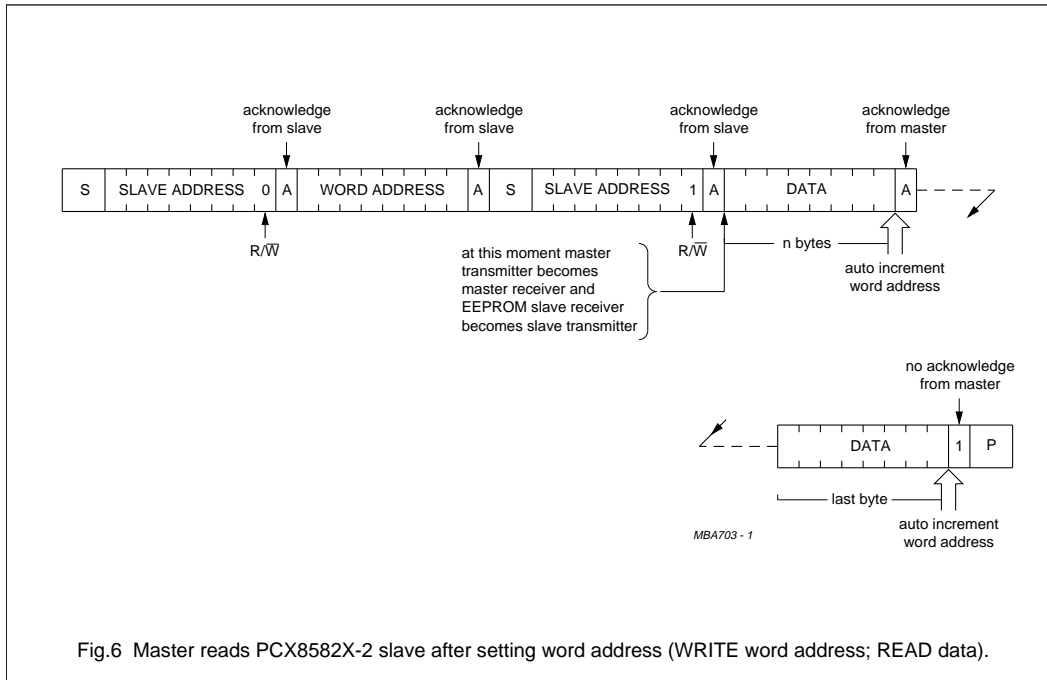

Fig.6 Master reads PCX8582X-2 slave after setting word address (WRITE word address; READ data).

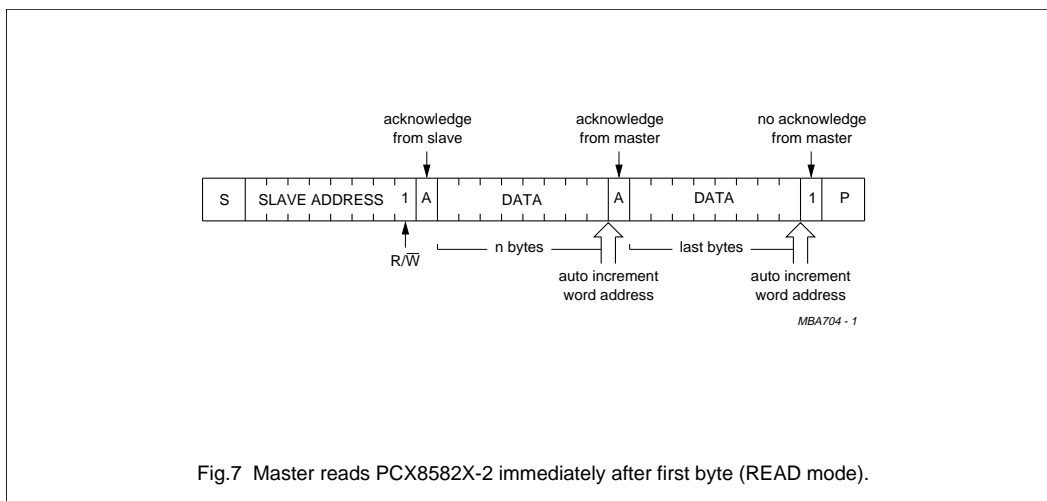

Fig.7 Master reads PCX8582X-2 immediately after first byte (READ mode).

256 x 8-bit CMOS EEPROMS
with I²C-bus interface

PCX8582X-2 Family

I²C-BUS TIMING

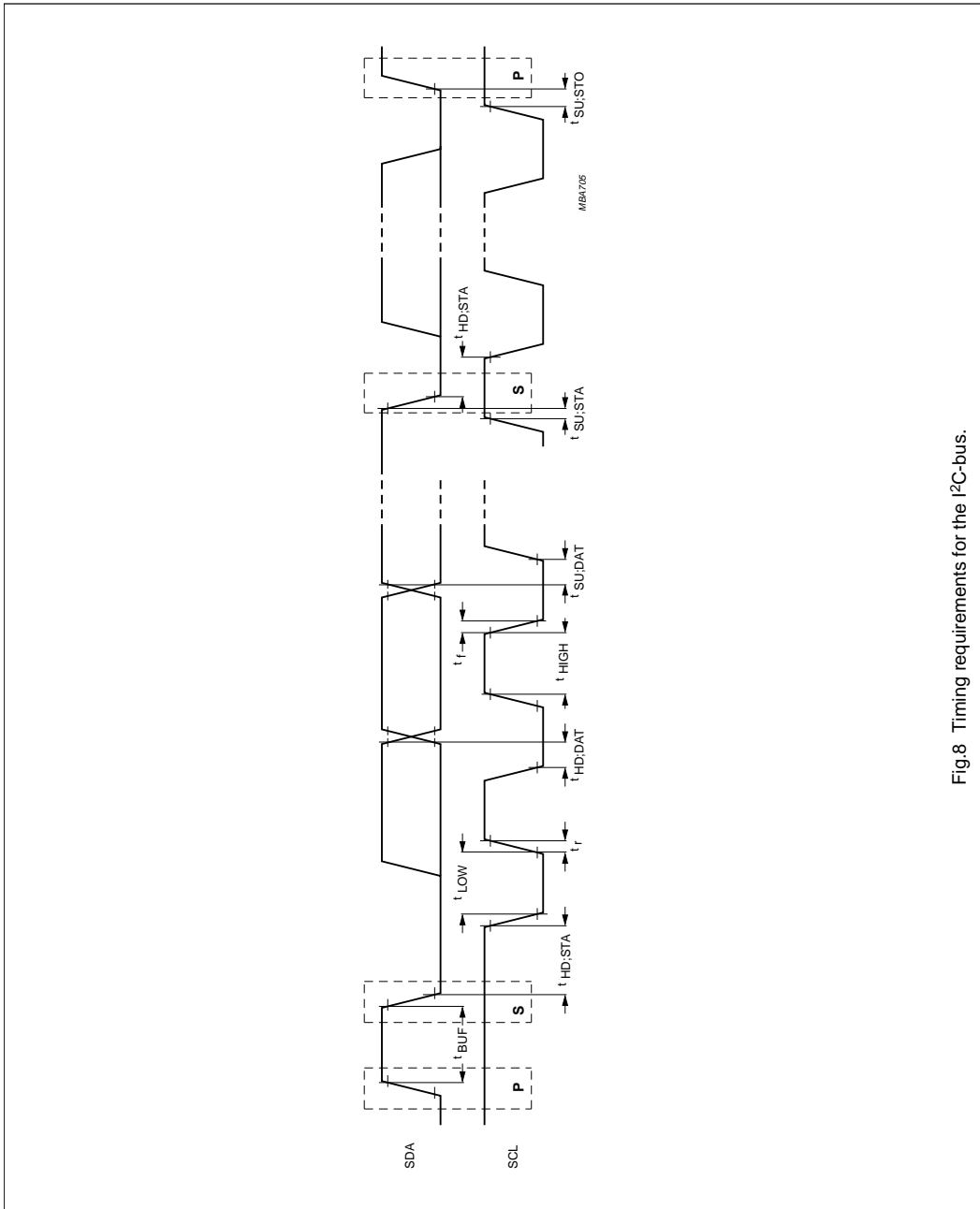

Fig.8 Timing requirements for the I²C-bus.

256 x 8-bit CMOS EEPROMS with I²C-bus interface

PCX8582X-2 Family

I²C-BUS CHARACTERISTICS

All of the timing values are valid within the operating supply voltage and ambient temperature range and refer to V_{IL} and V_{IH} with an input voltage swing from V_{SS} to V_{DD} .

SYMBOL	PARAMETER	CONDITIONS	MIN.	MAX.	UNIT
f_{SCL}	clock frequency		0	100	kHz
t_{BUF}	time the bus must be free before new transmission can start		4.7	–	μ s
$t_{HD;STA}$	start condition hold time after which first clock pulse is generated		4.0	–	μ s
t_{LOW}	LOW level clock period		4.7	–	μ s
t_{HIGH}	HIGH level clock period		4.0	–	μ s
$t_{SU;STA}$	set-up time for start condition	repeated start	4.7	–	μ s
$t_{HD;DAT}$	data hold time for bus compatible masters		5	–	μ s
$t_{HD;DAT}$	data hold time for bus devices	note 1	0	–	ns
$t_{SU;DAT}$	data set-up time		250	–	ns
t_r	SDA and SCL rise time		–	1	μ s
t_f	SDA and SCL fall time		–	300	ns
$t_{SU;STO}$	set-up time for stop condition		4.7	–	μ s

Note

1. The hold time required (not greater than 300 ns) to bridge the undefined region of the falling edge of SCL must be internally provided by a transmitter.

256 x 8-bit CMOS EEPROMS
with I²C-bus interface

PCX8582X-2 Family

EXTERNAL CLOCK TIMING

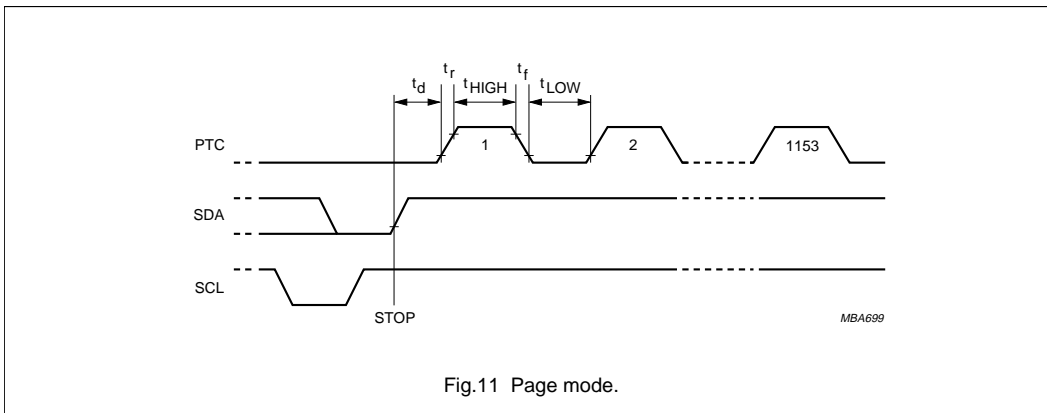
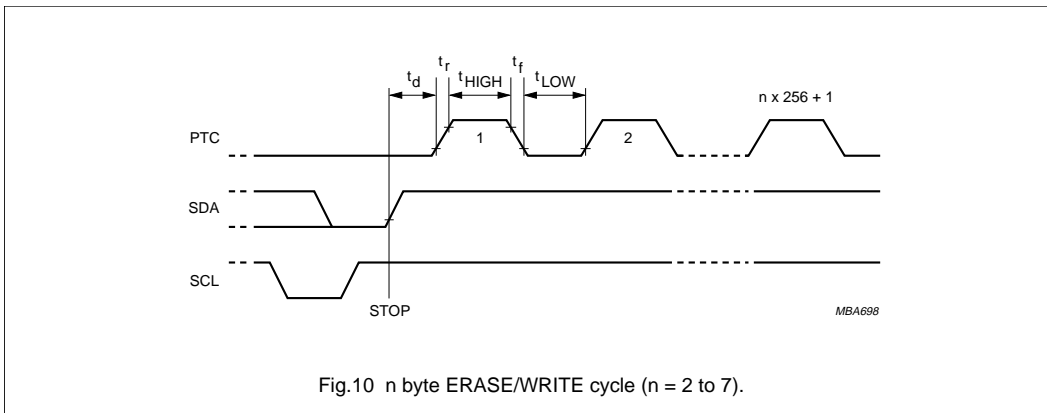
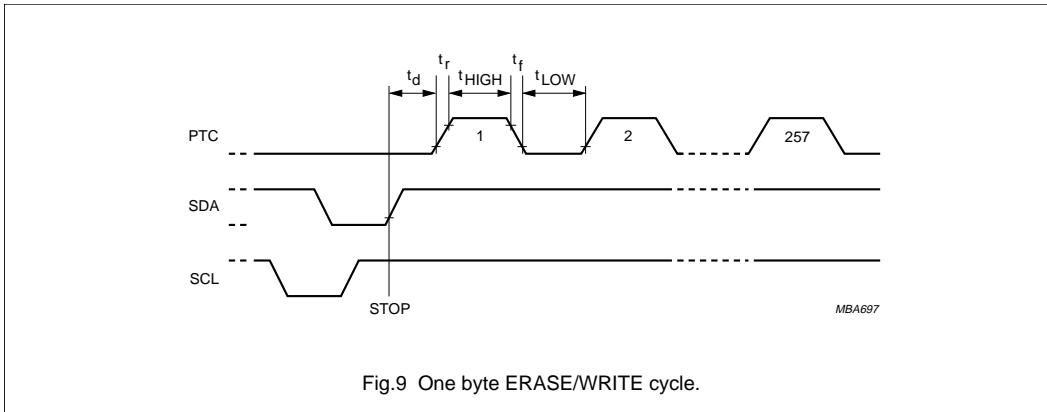

256 x 8-bit CMOS EEPROMS
with I²C-bus interface

PCX8582X-2 Family

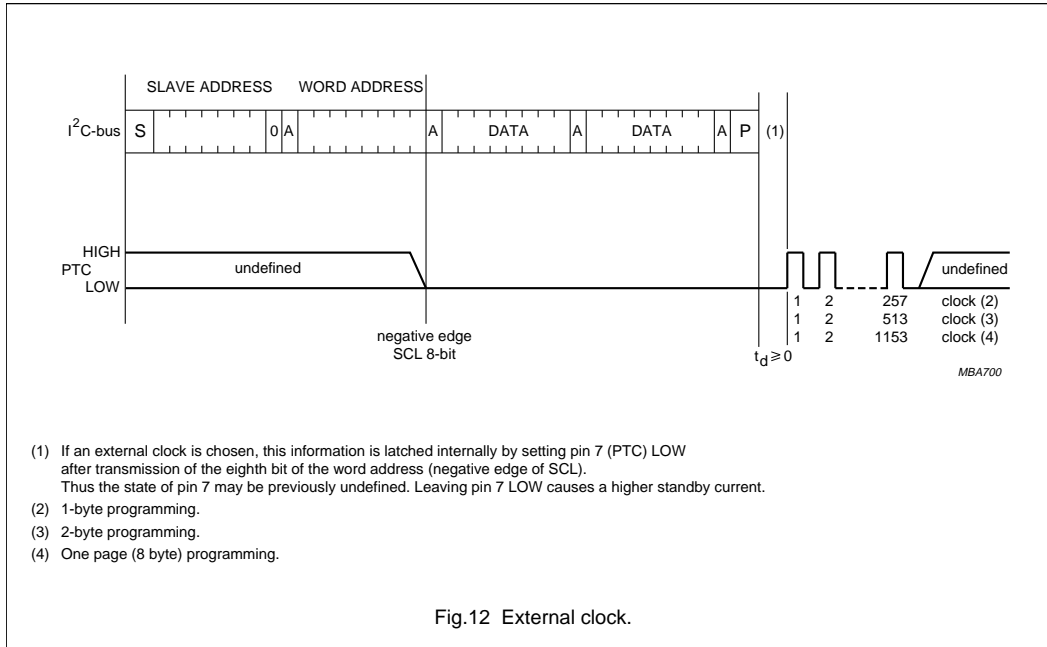

256 x 8-bit CMOS EEPROMS
with I²C-bus interface

PCX8582X-2 Family

PACKAGE OUTLINES

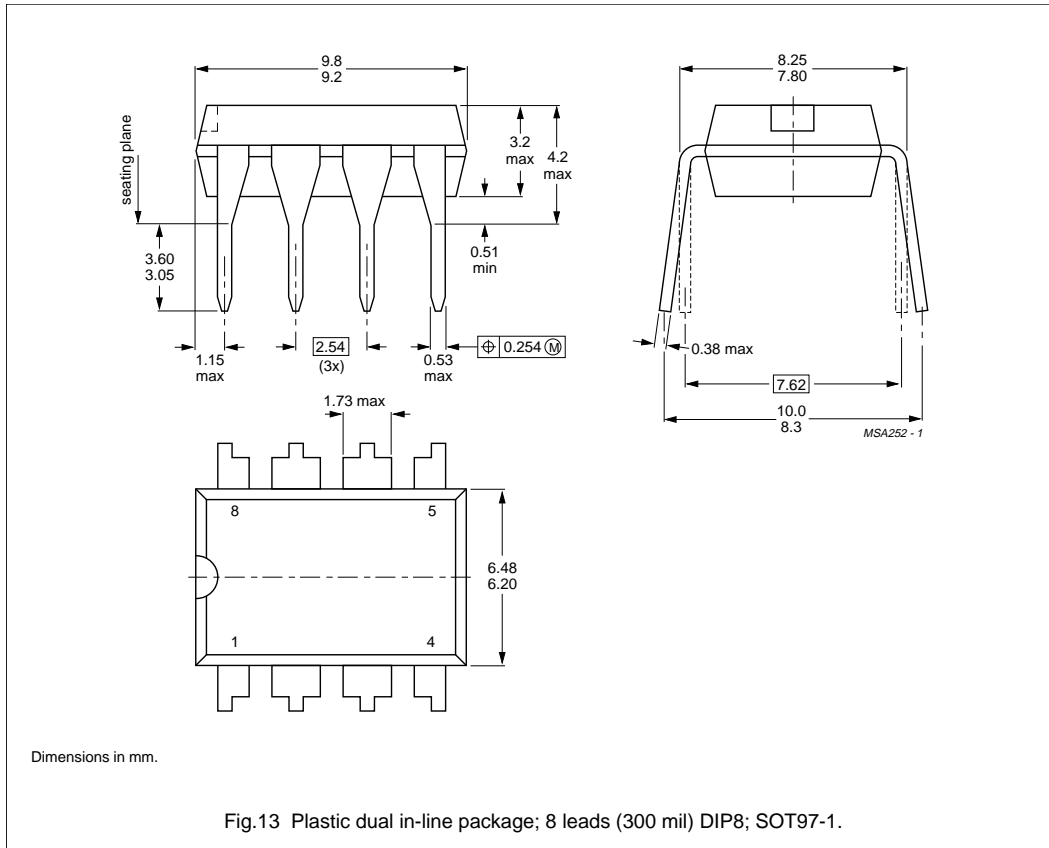

256 x 8-bit CMOS EEPROMS
with I²C-bus interface

PCX8582X-2 Family

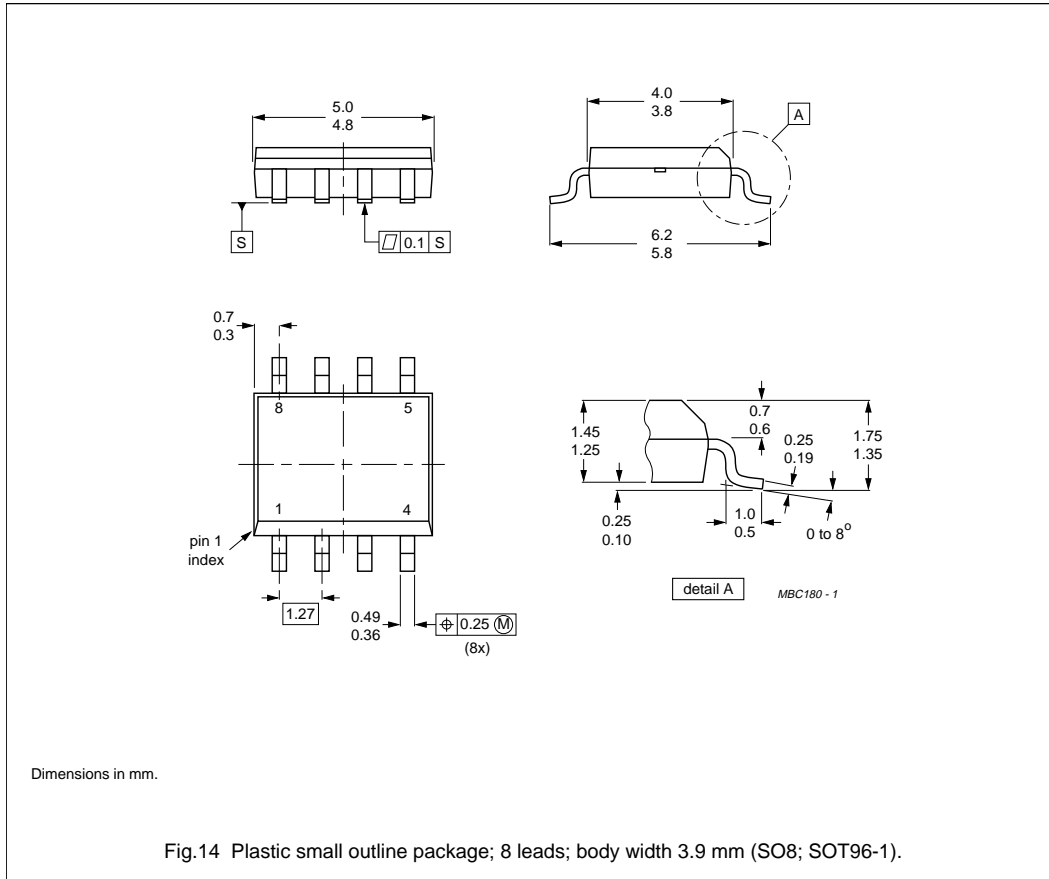

**256 x 8-bit CMOS EEPROMS
with I²C-bus interface**

PCX8582X-2 Family

SOLDERING**Plastic dual in-line packages**

BY DIP OR WAVE

The maximum permissible temperature of the solder is 260 °C; this temperature must not be in contact with the joint for more than 5 s. The total contact time of successive solder waves must not exceed 5 s.

The device may be mounted up to the seating plane, but the temperature of the plastic body must not exceed the specified storage maximum. If the printed-circuit board has been pre-heated, forced cooling may be necessary immediately after soldering to keep the temperature within the permissible limit.

REPAIRING SOLDERED JOINTS

Apply a low-voltage soldering iron below the seating plane (or not more than 2 mm above it). If its temperature is below 300 °C, it must not be in contact for more than 10 s; if between 300 and 400 °C, for not more than 5 s.

Plastic small-outline packages

BY WAVE

During placement and before soldering, the component must be fixed with a droplet of adhesive. After curing the adhesive, the component can be soldered. The adhesive can be applied by screen printing, pin transfer or syringe dispensing.

Maximum permissible solder temperature is 260 °C, and maximum duration of package immersion in solder bath is 10 s, if allowed to cool to less than 150 °C within 6 s. Typical dwell time is 4 s at 250 °C.

A modified wave soldering technique is recommended using two solder waves (dual-wave), in which a turbulent wave with high upward pressure is followed by a smooth laminar wave. Using a mildly-activated flux eliminates the need for removal of corrosive residues in most applications.

BY SOLDER PASTE REFLOW

Reflow soldering requires the solder paste (a suspension of fine solder particles, flux and binding agent) to be applied to the substrate by screen printing, stencilling or pressure-syringe dispensing before device placement.

Several techniques exist for reflowing; for example, thermal conduction by heated belt, infrared, and vapour-phase reflow. Dwell times vary between 50 and 300 s according to method. Typical reflow temperatures range from 215 to 250 °C.

Preheating is necessary to dry the paste and evaporate the binding agent. Preheating duration: 45 min at 45 °C.

REPAIRING SOLDERED JOINTS (BY HAND-HELD SOLDERING IRON OR PULSE-HEATED SOLDER TOOL)

Fix the component by first soldering two, diagonally opposite, end pins. Apply the heating tool to the flat part of the pin only. Contact time must be limited to 10 s at up to 300 °C. When using proper tools, all other pins can be soldered in one operation within 2 to 5 s at between 270 and 320 °C. (Pulse-heated soldering is not recommended for SO packages.)

For pulse-heated solder tool (resistance) soldering of VSO packages, solder is applied to the substrate by dipping or by an extra thick tin/lead plating before package placement.

256 x 8-bit CMOS EEPROMS with I²C-bus interface

PCX8582X-2 Family

DEFINITIONS

Data sheet status	
Objective specification	This data sheet contains target or goal specifications for product development.
Preliminary specification	This data sheet contains preliminary data; supplementary data may be published later.
Product specification	This data sheet contains final product specifications.
Limiting values	
Limiting values given are in accordance with the Absolute Maximum Rating System (IEC 134). Stress above one or more of the limiting values may cause permanent damage to the device. These are stress ratings only and operation of the device at these or at any other conditions above those given in the Characteristics sections of the specification is not implied. Exposure to limiting values for extended periods may affect device reliability.	
Application information	
Where application information is given, it is advisory and does not form part of the specification.	

LIFE SUPPORT APPLICATIONS

These products are not designed for use in life support appliances, devices, or systems where malfunction of these products can reasonably be expected to result in personal injury. Philips customers using or selling these products for use in such applications do so at their own risk and agree to fully indemnify Philips for any damages resulting from such improper use or sale.

PURCHASE OF PHILIPS I²C COMPONENTS



Purchase of Philips I²C components conveys a license under the Philips' I²C patent to use the components in the I²C system provided the system conforms to the I²C specification defined by Philips. This specification can be ordered using the code 9398 393 40011.

Philips Semiconductors – a worldwide company

Argentina: IEROD, Av. Juramento 1992 - 14, b. (1428)
BUENOS AIRES, Tel. (541)786 7633, Fax. (541)786 9367

Australia: 34 Waterloo Road, NORTH RYDE, NSW 2113,
Tel. (02)805 4455, Fax. (02)805 4466

Austria: Thnerstr. 64, A-1101 WIEN, P.O. Box 213,
Tel. (01)60 101-1236, Fax. (01)60 101-1211

Belgium: Postbus 90050, 5600 PB EINDHOVEN, The Netherlands,
Tel. (31)40 783 749, Fax. (31)40 788 399

Brazil: Rua do Rocio 220 - 5th floor, Suite 51,
CEP: 04552-903-SÃO PAULO-SP, Brazil.
P.O. Box 7383 (01064-970),
Tel. (011)821-2333, Fax. (011)829-1849

Canada: PHILIPS SEMICONDUCTORS/COMPONENTS:
Tel. (800) 234-7381, Fax. (708) 296-8556

Chile: Av. Santa María 0760, SANTIAGO,
Tel. (02)773 816, Fax. (02)777 6730

Colombia: IPRELENZO LTDA, Carrera 21 No. 56-17,
77621 BOGOTÁ, Tel. (571)249 7624/(571)217 4609,
Fax. (571)217 4549

Denmark: Prags Boulevard 80, PB 1919, DK-2300 COPENHAGEN S,
Tel. (032)88 2636, Fax. (031)57 1949

Finland: Sinikalliontie 3, FIN-02630 ESPOO,
Tel. (9)0-50261, Fax. (9)0-520971

France: 4 Rue du Port-aux-Vins, BP317,
92156 SURESNES Cedex,
Tel. (01)4099 6161, Fax. (01)4099 6427

Germany: P.O. Box 10 63 23, 20043 HAMBURG,
Tel. (040)3296-0, Fax. (040)3296 213.

Greece: No. 15, 25th March Street, GR 17778 TAVROS,
Tel. (01)4894 339/4894 911, Fax. (01)4814 240

Hong Kong: PHILIPS HONG KONG Ltd., 6/F Philips Ind. Bldg.,
24-28 Kung Yip St., KWAI CHUNG, N.T.,
Tel. (852)424 5121, Fax. (852)428 6729

India: Philips INDIA Ltd, Shivsagar Estate, A Block,
Dr. Annie Besant Rd. Worli, Bombay 400 018
Tel. (022)4938 541, Fax. (022)4938 722

Indonesia: Philips House, Jalan H.R. Rasuna Said Kav. 3-4,
P.O. Box 4252, JAKARTA 12950,
Tel. (021)5201 122, Fax. (021)5205 189

Ireland: Newstead, Clonskeagh, DUBLIN 14,
Tel. (01)640 000, Fax. (01)640 200

Italy: PHILIPS SEMICONDUCTORS S.r.l.,
Piazza IV Novembre 3, 20124 MILANO,
Tel. (0039)2 6752 2531, Fax. (0039)2 6752 2557

Japan: Philips Bldg 13-37, Kohnan2-chome, Minato-ku, TOKYO 108,
Tel. (03)3740 5028, Fax. (03)3740 0580

Korea: (Republic of) Philips House, 260-199 Itaewon-dong,
Yongsan-ku, SEOUL, Tel. (02)794-5011, Fax. (02)798-8022

Malaysia: No. 76 Jalan Universiti, 46200 PETALING JAYA,
SELANGOR, Tel. (03)750 5214, Fax. (03)757 4880

Mexico: 5900 Gateway East, Suite 200, EL PASO, TX 79905,
Tel. 9-5(800)234-7381, Fax. (708)296-8556

Netherlands: Postbus 90050, 5600 PB EINDHOVEN, Bldg. VB
Tel. (040)783749, Fax. (040)788399

New Zealand: 2 Wagoner Place, C.P.O. Box 1041, AUCKLAND,
Tel. (09)849-4160, Fax. (09)849-7811

Norway: Box 1, Manglerud 0612, OSLO,
Tel. (022)74 8000, Fax. (022)74 8341

Pakistan: Philips Electrical Industries of Pakistan Ltd.,
Exchange Bldg. ST-2/A, Block 9, KDA Scheme 5, Clifton,
KARACHI 75600, Tel. (021)587 4641-49,
Fax. (021)577035/5874546.

Philippines: PHILIPS SEMICONDUCTORS PHILIPPINES Inc.,
106 Valero St. Salcedo Village, P.O. Box 2108 MCC, MAKATI,
Metro MANILA, Tel. (02)810 0161, Fax. (02)817 3474

Portugal: PHILIPS PORTUGUESA, S.A.,
Rua dr. António Loureiro Borges 5, Arquiparque - Miraflores,
Apartado 300, 2795 LINDA-A-VELHA,
Tel. (01)4163160/4163333, Fax. (01)4163174/4163366.

Singapore: Lorong 1, Toa Payoh, SINGAPORE 1231,
Tel. (65)350 2000, Fax. (65)251 6500

South Africa: S.A. PHILIPS Pty Ltd.,
195-215 Main Road Martindale, 2092 JOHANNESBURG,
P.O. Box 7430 Johannesburg 2000,
Tel. (011)470-5911, Fax. (011)470-5494.

Spain: Balmes 22, 08007 BARCELONA,
Tel. (03)301 6312, Fax. (03)301 42 43

Sweden: Kottbygatan 7, Akalla. S-164 85 STOCKHOLM,
Tel. (0)8-632 2000, Fax. (0)8-632 2745

Switzerland: Allmendstrasse 140, CH-8027 ZÜRICH,
Tel. (01)488 2211, Fax. (01)481 77 30

Taiwan: PHILIPS TAIWAN Ltd., 23-30F, 66, Chung Hsiao West
Road, Sec. 1, Taipei, Taiwan ROC, P.O. Box 22978,
TAIPEI 100, Tel. (02)388 7666, Fax. (02)382 4382.

Thailand: PHILIPS ELECTRONICS (THAILAND) Ltd.,
209/2 Sanpavuth-Bangna Road Prakanong,
Bangkok 10260, THAILAND,
Tel. (662)398-0141, Fax. (662)398-3319.

Turkey: Talatpasa Cad. No. 5, 80640 GÜLTEPE/ISTANBUL,
Tel. (0212)279 2770, Fax. (0212)269 3094

United Kingdom: Philips Semiconductors LTD.,
276 Bath Road, Hayes, MIDDLESEX UB3 5BX,
Tel. (081)730-5000, Fax. (081)754-8421

United States: 811 East Arques Avenue, SUNNYVALE,
CA 94088-3409, Tel. (800)234-7381, Fax. (708)296-8556

Uruguay: Coronel Mora 433, MONTEVIDEO,
Tel. (02)70-4044, Fax. (02)92 0601

For all other countries apply to: Philips Semiconductors,
International Marketing and Sales, Building BE-p,
P.O. Box 218, 5600 MD, EINDHOVEN, The Netherlands,
Telex 35000 phtrnl, Fax. +31-40-724825

SCD36 © Philips Electronics N.V. 1994

All rights are reserved. Reproduction in whole or in part is prohibited without the prior written consent of the copyright owner.

The information presented in this document does not form part of any quotation or contract, is believed to be accurate and reliable and may be changed without notice. No liability will be accepted by the publisher for any consequence of its use. Publication thereof does not convey nor imply any license under patent- or other industrial or intellectual property rights.

Printed in The Netherlands

493061/1500/02/pp20
Document order number:

Date of release: December 1994
9397 743 70011

Philips Semiconductors



PHILIPS