

### 1. CONFIGURATION & DIMENSIONS :

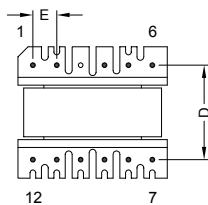
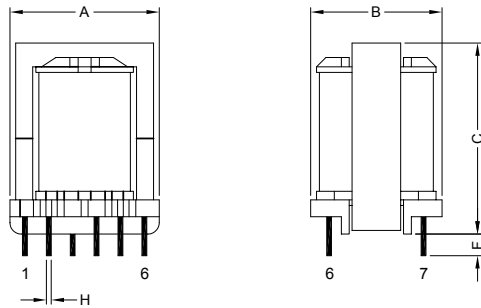

Unit:m/m

A	B	C	D	E	F	H
31.50 Max.	29.00 Max.	37.50 Max.	20.00±0.50	5.00±0.20	3.30±0.50	Ø0.80 Ref.

### 2. SCHEMATIC :

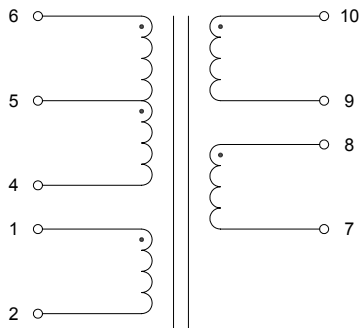

### 3. SCHEMATIC :

- Bobbin : Phenolic
- Core : ER28
- Wire : Polyurethane DD (2UEW)
- Tape : Polyester Film
- Varnish : Synthite AC-43
- Teflon Tube : Cat No.: TEF TW-300
- Nomex : 10mil

NOTE : Specifications subject to change without notice. Please check our website for latest information.



**RoHS Compliant**

19.06.2008



**SUPERWORLD ELECTRONICS (S) PTE LTD**

PG. 1

# HIGH FREQUENCY TRANSFORMER

SERC8VTF-50547

## 4. GENERAL SPECIFICATION :

- a) Operating Temperature Range : -25°C to +105°C
- b) Insulation Class : B (130°C)

## 5. ELECTRICAL CHARACTERISTICS :

Part No.	Inductance ( L )	Conditions	Test Frequency	DCR @ 25°C
SERC8VTF-50547	L : (6-4) = 2.4mH±20%	-	100KHz 0.1V	(6-5) = 0.55Ω Max.
	L : (8-7) = 87uH Min.	-	100KHz 0.1V	(1-2) = 173mΩ Max.
				(10-9) = 99mΩ Max.
				(8-9) = 207mΩ Max.
				(5-4) = 0.85Ω Max.



RoHS Compliant

NOTE : Specifications subject to change without notice. Please check our website for latest information.

19.06.2008



SUPERWORLD ELECTRONICS (S) PTE LTD

PG. 2