

100mA Low Dropout Linear Regulator

FEATURES

- Low Dropout Voltage of 130mV at 30mA Output Current (5V Output Version).
- Guaranteed 100mA Output Current.
- Internal P-MOSFET Draws no Base Current.
- Low Ground Current.
- Output Voltage of 3.0V/ 3.3V/ 3.6V/ 4.4V/ 5.0V Available.
- Input Voltage Range up to 14V.
- Needs only 1 μ F for Stability.

APPLICATIONS

- Audio/Video System
- Wireless Communication Systems.
- Battery Powered Systems.
- Toys.

DESCRIPTION

The AIC1720 is a 3-pin low dropout linear regulator. The superior characteristics of the AIC1720 include zero base current loss, low dropout voltage. Typical ground current remains approximately 55 μ A, from no load to maximum loading conditions. Dropout voltage at 30mA output current is low: 130mV for the AIC1720-44 and AIC1720-50, 180mV for the AIC1720-30, AIC1720-33, and AIC1720-36.

The AIC1720 comes in the popular 3-pin SOT-89, TO-92 and SO8 packages.

TYPICAL APPLICATION CIRCUIT

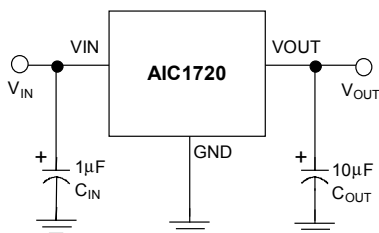

Low Dropout Linear Regulator

ORDERING INFORMATION

AIC1720-XXXXX

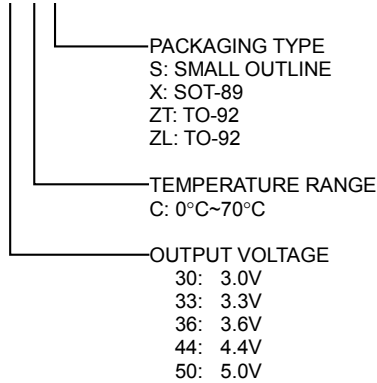

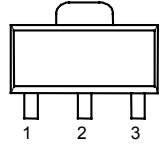
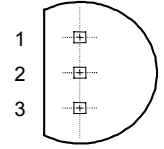
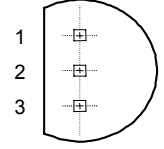
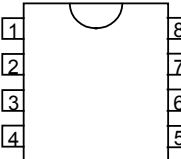
ORDER NUMBER	PIN CONFIGURATION
AIC1720-30CX AIC1720-33CX AIC1720-36CX AIC1720-44CX AIC1720-50CX (SOT-89)	FRONT VIEW 1: GND 2: VIN 3: VOUT 
AIC1720-30CZT AIC1720-33CZT AIC1720-36CZT AIC1720-44CZT AIC1720-50CZT (TO-92 T Type)	TOP VIEW 1: GND 2: VIN 3: VOUT 
AIC1720-30CZL AIC1720-33CZL AIC1720-36CZL AIC1720-44CZL AIC1720-50CZL (TO-92 L Type)	TOP VIEW 1: VIN 2: GND 3: VOUT 
AIC1720-30CS AIC1720-33CS AIC1720-36CS AIC1720-44CS AIC1720-50CS (SO-8)	TOP VIEW  VOUT [1] GND [2] GND [3] NC [4] [8] VIN [7] GND [6] GND [5] NC

ABSOLUTE MAXIMUM RATINGS

Input Supply Voltage.....	-0.3~14V
Operating Junction Temperature Range	-40°C~ 125°C
Storage Temperature Range	-65°C~150°C
Power Dissipation	
SO8 Package	0.625W
SOT-89 Package	0.5W
TO-92 Package	0.5W

TEST CIRCUIT

Refer to the TYPICAL APPLICATION CIRCUIT

ELECTRICAL CHARACTERISTICS ($T_a=25^\circ\text{C}$, $C_{IN}=1\mu\text{F}$, $C_{OUT}=10\mu\text{F}$, unless otherwise specified.)

PARAMETER	TEST CONDITIONS	MIN.	TYP.	MAX.	UNIT	
Output Voltage	No Load				V	
	AIC1720-50	$V_{IN}=5.5\sim 14\text{V}$	4.800	5.0		5.200
	AIC1720-44	$V_{IN}=5.5\sim 14\text{V}$	4.225	4.4		4.575
	AIC1720-36	$V_{IN}=4.0\sim 14\text{V}$	3.455	3.6		3.745
	AIC1720-33	$V_{IN}=4.0\sim 14\text{V}$	3.170	3.3		3.430
AIC1720-30	$V_{IN}=3.6\sim 14\text{V}$	2.880	3.0	3.120		
Output Voltage Temperature Coefficiency	(Note 1)		100	150	PPM/ $^\circ\text{C}$	
Line Regulation	$I_L=1\text{mA}$				mV	
	AIC1720-50	$V_{IN}=5.5\sim 14\text{V}$		5		10
	AIC1720-44	$V_{IN}=5.5\sim 14\text{V}$		5		10
	AIC1720-36	$V_{IN}=4.0\sim 14\text{V}$		5		10
	AIC1720-33	$V_{IN}=4.0\sim 14\text{V}$		5		10
AIC1720-30	$V_{IN}=3.6\sim 14\text{V}$		5	10		
Load Regulation (Note 2)	AIC1720-50	$V_{IN}=7\text{V}$,		10	25	mV
	AIC1720-44	$I_L=0.1\sim 100\text{mA}$		10	25	
	AIC1720-36	$V_{IN}=7\text{V}$,		10	25	
	AIC1720-33	$I_L=0.1\sim 100\text{mA}$		10	25	
	AIC1720-30	$V_{IN}=5\text{V}$,		10	25	
		$I_L=0.1\sim 100\text{mA}$				
		$V_{IN}=5\text{V}$,				
		$I_L=0.1\sim 100\text{mA}$				
		$V_{IN}=5\text{V}$,				
		$I_L=0.1\sim 100\text{mA}$				
Dropout Voltage (Note 4)	AIC1720s	$I_L=0.1\text{mA}$		0.2	10	mV
	AIC1720-50	$I_L=100\text{mA}$		400	500	
	AIC1720-44	$I_L=100\text{mA}$		400	500	
	AIC1720-36	$I_L=100\text{mA}$		540	640	
	AIC1720-33	$I_L=100\text{mA}$		540	640	
	AIC1720-30	$I_L=100\text{mA}$		540	640	
Ground Current	$I_O=0.1\text{mA}\sim I_{MAX}$				μA	
	AIC1720-50	$V_{IN}=5.5\sim 14\text{V}$		55		80
	AIC1720-44	$V_{IN}=5.5\sim 14\text{V}$		55		80
	AIC1720-36	$V_{IN}=4\sim 14\text{V}$		55		80
	AIC1720-33	$V_{IN}=4\sim 14\text{V}$		55		80
AIC1720-30	$V_{IN}=4\sim 14\text{V}$		55	80		

Note 1: Guaranteed by design.

Note 2: Regulation is measured at constant junction temperature, using pulse testing with a low ON time.

Note 3: Dropout voltage is defined as the input to output differential at which the output voltage drops 100mV below the value measured with a 1V differential.

■ ELECTRICAL CHARACTERISTICS

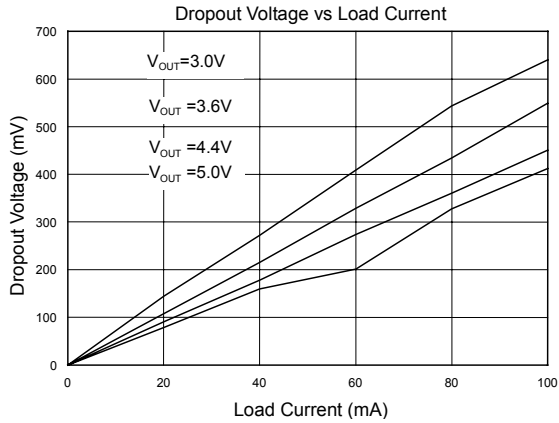

■ PHYSICAL DIMENSIONS

● SOT-89 (unit: mm)

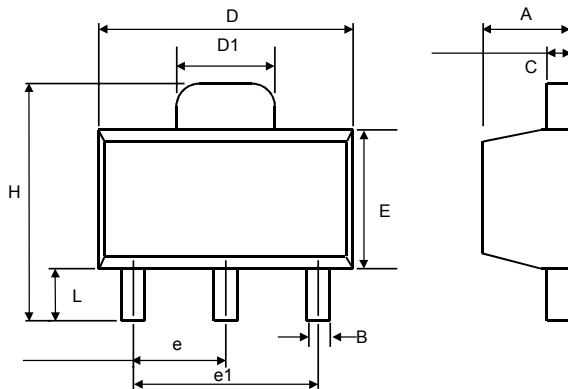

SYMBOL	MIN	MAX
A	1.40	1.60
B	0.36	0.48
C	0.35	0.44
D	4.40	4.60
D1	1.62	1.83
E	2.29	2.60
e	1.50 (TYP.)	
e1	3.00 (TYP.)	
H	3.94	4.25
L	0.89	1.20

● SOT-89 MARKING

Part No.	Marking
AIC1720-30CX	
AIC1720-33CX	
AIC1720-36CX	
AIC1720-44CX	
AIC1720-50CX	

- **TO-92 (unit: mm)**

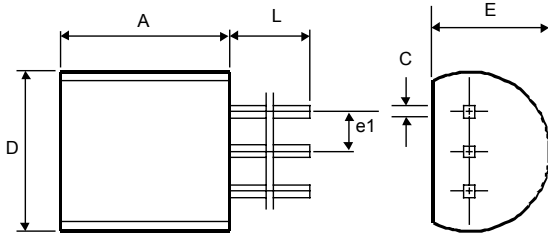

SYMBOL	MIN	MAX
A	4.32	5.33
C	0.38 (TYP.)	
D	4.40	5.20
E	3.17	4.20
e1	1.27 (TYP.)	
L	12.7	-

- **8 LEAD PLASTIC SO (unit: mm)**

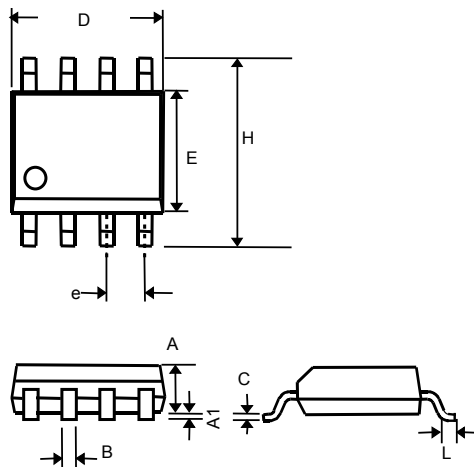

SYMBOL	MIN	MAX
A	1.35	1.75
A1	0.10	0.25
B	0.33	0.51
C	0.19	0.25
D	4.80	5.00
E	3.80	4.00
e	1.27 (TYP)	
H	5.80	6.20
L	0.40	1.27