

The WL800 is a low power single chip frequency synthesiser. The circuit is fabricated on Mitel Semiconductor HG process and operates from a supply voltage of 2.7 - 3.6V. It is designed to work with the Mitel Semiconductor WL600C RF and IF circuit and the WL102 WLAN controller chip which together make up the DE6038 frequency hopping Wireless Local Area Network (WLAN) transceiver.

FEATURES

- Low power consumption
- 2.5GHz input
- 144 frequencies, 1MHz steps (20MHz crystal)
- Forms complete phase locked loop using external VCO and loop components
- Serially programmed via 3 wire bus
- Contains anti-modulation circuit
- Part of DE6038 Chip-set (WL600C, WL102)

ORDERING INFORMATION

WL800/KG/TP1R

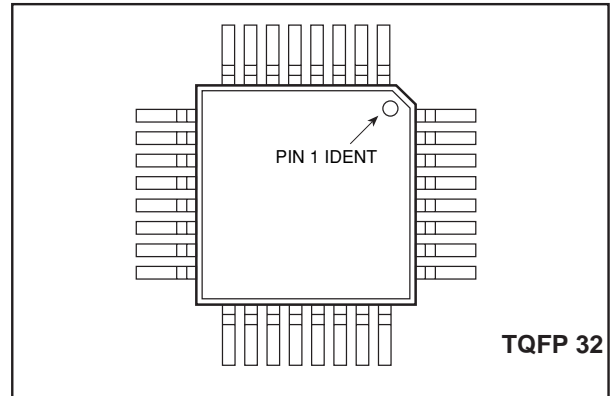

Fig.1 Pin connections - top view

RELATED DOCUMENTS

WL600C, WL102 datasheets

ABSOLUTE MAXIMUM RATINGS

Supply Voltage Vcc	4VDC
Transmit/Receive and Standby Input	-0.5VDC to Vcc +0.5VDC
Prescaler Inputs Pins 30 &31	No DC. Externally Capacitively Coupled.
Output Current (any output)	TBD mA
Junction temperature Tj	150°C
ESD protection:	2kV
Operating temperature	-20 to +85°C

WL800

DEVICE PIN OUT

PIN	REFERENCE	TYPE	DESCRIPTION
1	VCC1	VCC	Power for serial data bus
2	CS-DATA	IN	Channel Data in (Synth Programming)
3	CS-CLK	IN	Data Clock (Synth Programming)
4	CS-LOADB	IN	Data Enable (Synth Programming)
5	STDBYB	IN	Power down control Active = Logic 1 Standby = logic 0
6	VEE1	GND	Ground connection
7	ISSET		Set modulation current
8	ICP		Set charge pump current
9	VEE3	GND	Ground connection
10	TXD	IN	Modulation data in
11	COM CAP		Compensation capacitor for modulation data
12	RCOMP	OUT	Resistor for V/I converter
13	IDOUT	OUT	Modulation data out
14	TXRXB	IN	Transmit/Receive control Transmit = Logic 1 Receive = Logic 0
15	VARICAP	OUT	Control V to varicap in VCO
16	VCC3	VCC	Power for charge pump and loop amplifier and modulator
17	LOOPFILTER	OUT	Loop filter out (Loop Filter Components)
18	CPUMPREF		Charge pump reference voltage
19	CPUMPOUT	OUT	Charge pump out (Loop Filter Components)
20	VEE2	GND	Ground connection
21	SYSCLK	OUT	Reference (system) clock out
22	XTAL		Crystal connection (Differential)
23	XTALB		Crystal connection (Differential)
24	VCC2	VCC	Power for reference oscillator
25	FREF	OUT	Reference frequency monitor
26	LKCAP		Lock detect capacitor
27	LCKDETB	OUT	Lock detect output
28	FV	OUT	VCO frequency / (NM+A) monitor
29	VEE5	GND	Ground connection
30	VCC	VCC	Power for prescaler, AM counter Ref divider, phase detector and lock detector
31	VCOIPB	IN	Prescaler IN-
32	VCOIP	IN	Prescaler IN+

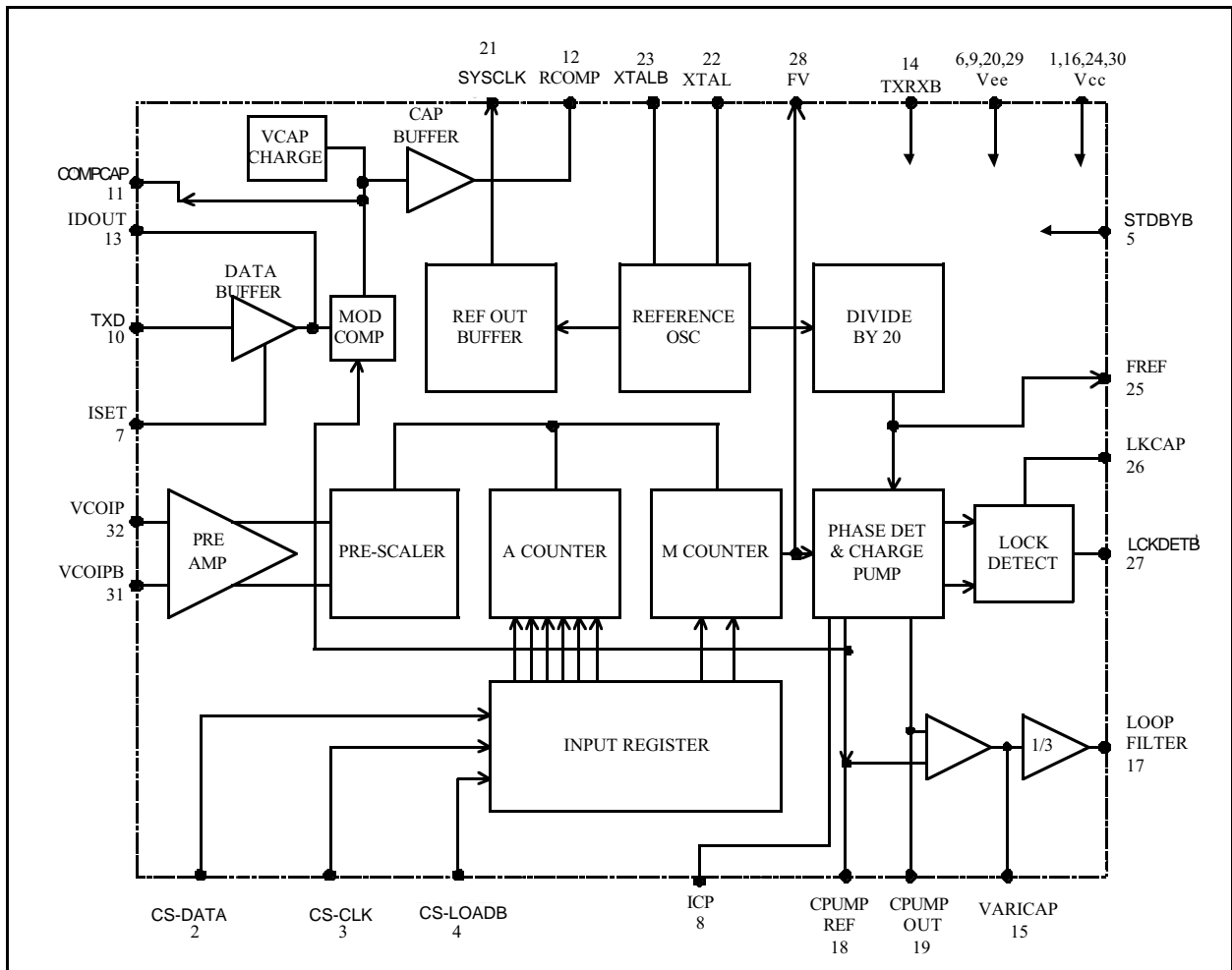

Fig. 1 WL800 block diagram

WL800

ELECTRICAL CHARACTERISTICS

These characteristics are guaranteed over the following conditions (unless otherwise stated):

$$T_{AMB} = -20^{\circ}\text{C, to } +85^{\circ}\text{C, } V_{CC} = 2.7\text{V to } 3.6\text{V}$$

Characteristic	Value			Unit	Condition
	MIN	TYP	MAX		
Supply current (total)					
Transmit		37	50	mA	
Receive		35	50	mA	
Supply current in standby		3	5	mA	
PROGRAMMING INPUTS					
Logic low voltage	0		0.4	V	
Logic high voltage	0.8V _{CC}		V _{CC}	V	
Input current			1	μA	Input level high
Data clock frequency (1/tclock)			20	MHz	See Fig. 2
Data/Enable set up time (t set up)	10			ns	See Fig. 2
Enable hold time (t enable)	10			ns	See Fig. 2
Positive clock pulse width (tp)	20			ns	See Fig. 2
Negative clock pulse width (t neg)	20			ns	See Fig. 2
STANDBY INPUT					
Logic low input voltage	0		0.8	V	Circuit powered down
Logic high input voltage	V _{CC} -0.7		V _{CC}	V	Circuit powered up
Input current		100	150	μA	Circuit powered up
			-150	μA	Circuit powered down
Standby to operate time		3		μs	*References operational (see note 1)
TX/RX INPUT					
Logic low input voltage	0		0.8	V	Receive mode
Logic high input voltage	V _{CC} -0.7		V _{CC}	V	Transmit mode
Input current			10	μA	
REFERENCE OUTPUT					
Reference output frequency		20		MHz	With 20MHz crystal
Reference clock output voltage	200	250	300	mVp-p	With 15pF load
Reference output impedance		600		Ohms	
Mark Space ratio	-2%	50/50	+2%		With 15pF load
Rise time			15	ns	
Fall time			15	ns	
Crystal Drive Levels required		200		mV	Pins 22,23 differential

ELECTRICAL CHARACTERISTICS (continued)

These characteristics are guaranteed over the following conditions (unless otherwise stated):

T_{AMB} = -20°C, to +85°C, V_{CC} = 2.7V to 3.6V

Characteristic	Value			Unit	Condition
	MIN	TYP	MAX		
LOCK DETECT CIRCUIT					
Smoothing capacitor charge/discharge current	80	110	150	μA	Determined by application.
Threshold voltage		V _{CC} -0.3		V	On smoothing capacitor
Output high voltage	1.8		V _{CC}	V	I _{out} = 10μA
Output low voltage	V _{EE}		0.5	V	I _{out} = 0 μA
PHASE DETECTOR AND CHARGE PUMP					
Comparison frequency		1		MHz	Divided crystal reference
Charge pump output current		±1		mA	R _{pin 8} = 10k
Up down current matching			5	%	
Reference voltage	V _{CC} -1.05		V _{CC} -0.7	V	
CHARGE PUMP OP-AMP					
First Stage:					
High output voltage	2.4			V	
Low output voltage			0.3	V	
Second Stage:					
Filter drive amplifier output current		±1		mA	
Filter drive amp output swing		0.77		V _{p-p}	
PRESCALER					
Input drive voltage	40		200	mV rms	
Maximum operating frequency	3			GHz	
Input Impedance		330Ω 0.5pF			
TRANSMIT DATA INPUT					
Logic low	-60		-100	μA	R _{source} =20k
Logic high	+60		+100	μA	
TX DATA OUT					
Logic 0 output current	25	50	100	μA	Set by external resistor on pin 7
Logic 1 output current			200	nA	Leakage Current
Output current in receive mode		25		μA	Equal to 0.5 mod current

WL800

ELECTRICAL CHARACTERISTICS (continued)

These characteristics are guaranteed over the following conditions (unless otherwise stated):

$$T_{AMB} = -20^{\circ}\text{C, to } +85^{\circ}\text{C, } V_{CC} = 2.7\text{V to } 3.6\text{V}$$

Characteristic	Value			Unit	Condition
	MIN	TYP	MAX		
MOD. CURRENT INPUT					
Mod current set pin current		25		μA	Set by external resistor on pin 7. R = 47k
COMPENSATION CAP PIN					
Compensation current		-25		μA	Set by external resistor on pin 7. R=47k.
Compensation current matching			2	%	Compensation capacitor 8.2nF
Compensation capacitor voltage	CPreF - 0.02	CPreF	CPreF +0.02	V	Receive mode
Compensation capacitor voltage	88	98	+110	mV	1 MHz data, 32bits '0'
	-120	-98	-88	mV	1 MHz data, 32bits '1'
VCAP CHARGE					
Settling Time			100	μs	Receive mode
Charging Current			20	mA	Receive mode. Vcap initially at 0 V.
Offset Voltage			15	mV	Receive mode.
COMPENSATION Vtol (CAPBUFFER+RCOMP)					
Compensation current into Loop		+52.08		nA	Per 1us of databit 0
Filter		-52.08		nA	Per 1us of databit 1
Max. Compensation current		1.666		mA	for 32 bits(1) at 1MHz
CAPACITOR BUFFER					
Offset Voltage		15		mV	
External Resistor RCOMP		58000		Ohms	

Note: 1. Standby to operate time refers to the time for internal current references to become operational.

FUNCTIONAL DESCRIPTION

Reference Frequency

The reference frequency is generated using a 20MHz crystal in conjunction with an on chip oscillator maintaining circuit. A buffer circuit provides a low level voltage output signal at the crystal frequency to drive the logic in the protocol and control chip. The crystal frequency is divided by 20 to provide the reference signal to the phase comparator.

Counters / Dividers

An external oscillator is used to feed the input of the preamplifier in the synthesiser, (this isolates the counters from the oscillator and reduces the level of drive signal required by the synthesiser). The output of the preamplifier drives a dual modulus prescaler with ratios of 48/49, which in turn then drives the standard A-M counter arrangement. The A counter then provides the modulus control signal back to the prescaler. The counter system has an overall division ratio given by the formula $MN+A$ where N is the lower divide ratio of the prescaler (48).

The divide ratio of the M and A counters is programmable to allow the oscillator to be tuned over the required frequency range of 144 channels at 1MHz spacing. The M count ratio can be programmed over the range 49 to 52 and the A counter from 1 to 48 giving a total divide ratio from 2353 to 2544 which is greater than necessary to tune the required frequency range.

Programming

The programming data for the synthesiser is entered via a three wire serial data bus consisting of Enable, Clock and Data signals.

The enable signal is taken low at the start of the programming sequence and remains low for the duration of the 8 serial data bits. A positive clock edge is required to strobe each data bit into the input register. When all 8 data bits are entered, the enable pin is taken high forcing the counters to zero and preloading the new count data when the counter is next clocked. The charge pump is disabled for a short period after the enable pin goes low to prevent glitch energy being transferred to the VCO.

Phase Detectors

A conventional digital phase frequency detector incorporating dead band suppression is used in conjunction with a charge pump to steer the VCO. An internal op-amp maintains the charge pump pin at the same voltage as the charge pump reference by virtual earth principles. The op-amp is split into two parts with the first section having a relatively low current drive capability but including the high gain stages of the amplifier. The second stage has a controlled voltage gain of 1/3 but high input impedance and low output impedance. This minimises loading to the high output impedance of the first stage and provides sufficient drive current via the loop filter to maintain virtual earth at the charge pump output. The output from the first stage is designed to swing close to the positive and negative rails so as to provide maximum voltage swing to the varactor controlling the VCO. A compensating capacitor can be connected to this point to stabilise the amplifier.

A lock detect output (active low) is provided to give an indication to the controller that the phase locked loop is locked, preventing transmission on illegal frequencies.

Antimodulation

The WL800 contains a data buffer circuit which accepts transmit data from the CMOS controller circuit and converts the CMOS input to a tristate current output for driving the transmit spectrum shaping filter. The buffer gives zero current for a logic "1" input, a high current (+2I) for a logic "0" and a current midway between the two (+I) for use during the transmit amplifier power up/down period and during receive. This function prevents the synthesiser centring its frequency on either a logic "1" or "0" and removes the possibility of over-modulation at the start of a transmission. The amplitude of the output current and therefore modulation index of the radio is controlled by an external resistor connected to ground. A data compensation path is included which counteracts the tendency of the PLL to drift back to centre frequency when the data is non-white. This is achieved by charging an external capacitor with a current +I when data is low, and discharging it by a current -I when data is high. The capacitor voltage, which then represents an integrated form of the data is converted to a current via a buffer and an external resistor (RCOMP), and fed into the Loop Filter in addition to the Phase Detector output. During Receive Mode, the capacitor is charged to the Charge Pump Reference voltage.

WL800

WL800 PROGRAMMING

Frequency MHz	A counter Value	M counter Value	6 bit binary A Value d0-d5	bit binary M Value d6-d7
2357	5	49	101000	00
2358	6	49	011000	00
2400	48	49	000011	00
2401	1	50	100000	10
2448	48	50	000011	10
2449	1	51	100000	01
2496	48	51	000011	01
2497	1	52	100000	11
2498	2	52	010000	11
2499	3	52	110000	11
2500	4	52	001000	11

- Notes: 1.The binary data is in reverse order.
2.The data is programmed with bit d7 first and d0 last

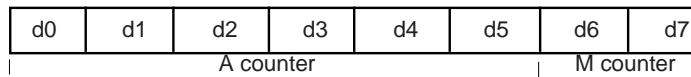

TIMING DIAGRAM

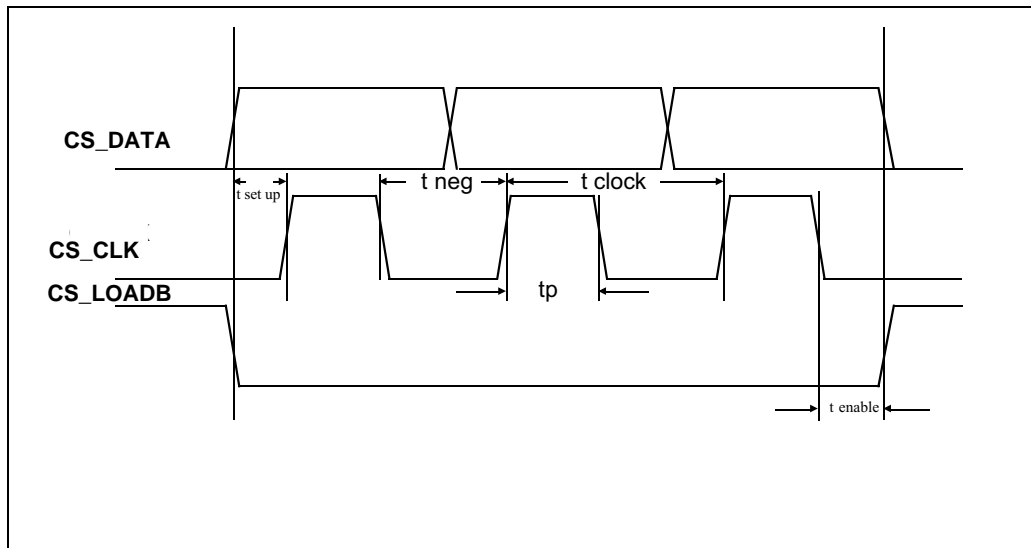
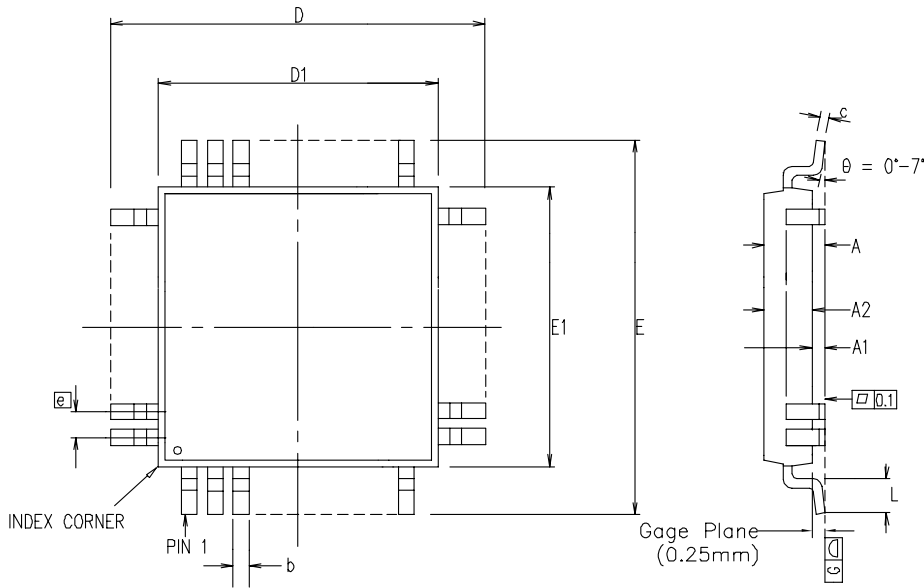

Fig. 2 Timing diagram

CONTROL SIGNALS

Control Line	Logic '0'	Logic '1'
STDBYB TXRXB LCKDETB	Standby Receive Locked	Active Transmit Unlocked



Symbol	Control Dimensions in millimetres		Altern. Dimensions in inches	
	MIN	MAX	MIN	MAX
A	---	1.20	---	0.047
A1	0.05	0.15	0.002	0.006
A2	0.95	1.05	0.037	0.041
D	9.00 BSC		0.354 BSC	
D1	7.00 BSC		0.276 BSC	
E	9.00 BSC		0.354 BSC	
E1	7.00 BSC		0.276 BSC	
L	0.45	0.75	0.018	0.030
e	0.80 BSC		0.031 BSC	
b	0.30	0.45	0.012	0.018
c	0.09	0.20	0.004	0.008
Pin features				
N	32			
ND	8			
NE	8			
NOTE	SQUARE			

Conforms to JEDEC MS-026 ABA Iss. C

Notes:

1. Pin 1 indicator may be a corner chamfer, dot or both.
2. Controlling dimensions are in millimeters.
3. The top package body size may be smaller than the bottom package body size by a max. of 0.15 mm.
4. Dimension D1 and E1 do not include mould protusion.
5. Dimension b does not include dambar protusion.
6. Coplanarity, measured at seating plane G, to be 0.10 mm max.

This drawing supersedes 418/ED/51612/001 (Swindon)

© Mitel

ORIGINATING SITE: SWINDON

ISSUE	1	2			
ACN	201348	207076			
DATE	25OCT96	6JUL99			
APPROVED					

MITEL SEMICONDUCTOR

Title: Package Outline Drawing for
32 lds TQFP (TP)
(7x7x1.0) mm, Body+2.0 mm

Drawing Number
GPD00233



<http://www.mitelsemi.com>

World Headquarters - Canada

Tel: +1 (613) 592 2122
Fax: +1 (613) 592 6909

North America

Tel: +1 (770) 486 0194
Fax: +1 (770) 631 8213

Asia/Pacific

Tel: +65 333 6193
Fax: +65 333 6192

**Europe, Middle East,
and Africa (EMEA)**

Tel: +44 (0) 1793 518528
Fax: +44 (0) 1793 518581

Information relating to products and services furnished herein by Mitel Corporation or its subsidiaries (collectively "Mitel") is believed to be reliable. However, Mitel assumes no liability for errors that may appear in this publication, or for liability otherwise arising from the application or use of any such information, product or service or for any infringement of patents or other intellectual property rights owned by third parties which may result from such application or use. Neither the supply of such information or purchase of product or service conveys any license, either express or implied, under patents or other intellectual property rights owned by Mitel or licensed from third parties by Mitel, whatsoever. Purchasers of products are also hereby notified that the use of product in certain ways or in combination with Mitel, or non-Mitel furnished goods or services may infringe patents or other intellectual property rights owned by Mitel.

This publication is issued to provide information only and (unless agreed by Mitel in writing) may not be used, applied or reproduced for any purpose nor form part of any order or contract nor to be regarded as a representation relating to the products or services concerned. The products, their specifications, services and other information appearing in this publication are subject to change by Mitel without notice. No warranty or guarantee express or implied is made regarding the capability, performance or suitability of any product or service. Information concerning possible methods of use is provided as a guide only and does not constitute any guarantee that such methods of use will be satisfactory in a specific piece of equipment. It is the user's responsibility to fully determine the performance and suitability of any equipment using such information and to ensure that any publication or data used is up to date and has not been superseded. Manufacturing does not necessarily include testing of all functions or parameters. These products are not suitable for use in any medical products whose failure to perform may result in significant injury or death to the user. All products and materials are sold and services provided subject to Mitel's conditions of sale which are available on request.

M Mitel (design) and ST-BUS are registered trademarks of MITEL Corporation
Mitel Semiconductor is an ISO 9001 Registered Company
Copyright 1999 MITEL Corporation
All Rights Reserved
Printed in CANADA

TECHNICAL DOCUMENTATION - NOT FOR RESALE