

MPC17559

Micromotor Driver with Dual 3-Phase and Dual H-Bridge Outputs

Power Actuation

H-Bridge Motor Drivers

DESCRIPTION

The 17559 is a monolithic quad H-Bridge power IC ideal for portable electronic applications containing multiple brushless and brush DC-motors.

The 17559 is designed to drive motors with supplies operating from 0.9 V to 3.5 V, with independent control of each output bridge via parallel 1.8 V to 3.6 V logic-compatible I/O. Each output bridge has its own gate-drive and logic circuitry with built-in shoot-through current protection.

The 17559 has a low total $R_{DS(ON)}$ of 1.7 Ω max @ 25°C for each of the two 3-phase output bridges, and a low total $R_{DS(ON)}$ of 1.3 Ω max @ 25°C for each of the two H-Bridge outputs.

The 17559 can efficiently drive many types of micromotors owing to its low output resistance and high output slew rates.

17559 SIMPLIFIED APPLICATION DIAGRAM

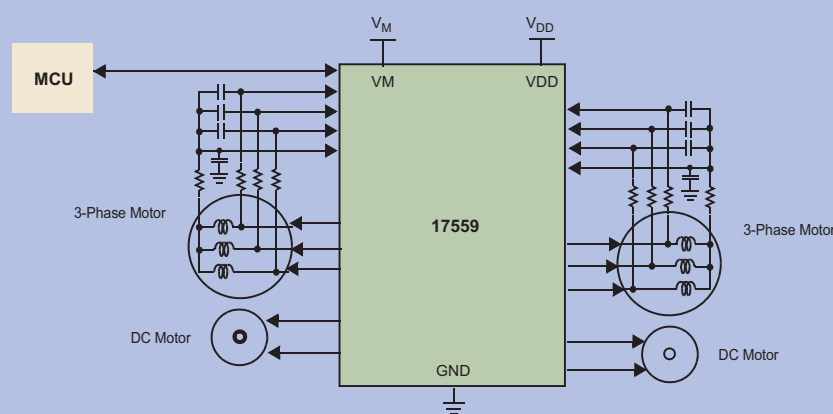

APPLICATIONS

- Portable Electronics
- Optical Disc Drive (MO, DVD, and CD)
- DSC, DVC
- Robotics

PERFORMANCE

TYPICAL VALUES

Performance	2 ch H-Bridge, 2 ch Stepper
Output Current	0.3 A (DC), 0.6 A (Peak)
Motor Operating Voltage	0.9 V – 3.5 V
Logic Operating Voltage	1.8 V – 3.5 V
Input PWM Max	200 kHz
Operating Temperature	-20°C ≤ T _A ≤ 65°C

FEATURES

- Two separate three-phase motor drivers
- Two separate H-bridge motor drivers
- Low-voltage detection and shutdown circuitry
- Pb-free packaging designated by suffix code EP
- Devices available for comparison are in the Analog Product Selector Guide - SG1002, and Automotive Product Selector Guide - SG187.

QUESTIONS

- Are you working with portable electronic battery-powered applications?
- Do you need to control a stepper or brushless DC-motor in a 3 V or 5 V system?
- Are you designing a brushless DC-motor controller for motors up to 2 A (peak) and 6.8 V DC?

PROTECTION

DETECTION

SHUT DOWN

Undervoltages



CUSTOMER BENEFITS

- Easy MCU interfacing and control
- Undervoltage protection to prevent erratic operation
- High PWM rate for enhanced motor control
- Low profile package for portable designs
- Integral charge pump for simpler system
- Low quiescent current
- Two H-Bridges and two three Phase Motor Driver outputs integrated in one package
- Reduced design time

ORDERING INFORMATION

Device	Temperature Range (T _A)	Package
MPC17559EP/R2	-20°C to 65°C	56 QFN
Data Sheet Order Number		MPC17559

Contact Sales for Evaluation Kit Availability

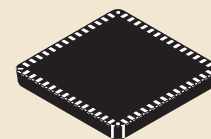

56 QFN
0.5 mm Pitch
8 mm x 8 mm x 1.0 mm Body