

MPC7457 RISC Microprocessor Hardware Specifications

This hardware specification is primarily concerned with the MPC7457; however, unless otherwise noted, all information here also applies to the MPC7447. The MPC7457 and MPC7447 are implementations of the PowerPC™ microprocessor family of reduced instruction set computer (RISC) microprocessors. This hardware specification describes pertinent electrical and physical characteristics of the MPC7457. For functional characteristics of the processor, refer to the *MPC7450 RISC Microprocessor Family User's Manual*.

To locate any published updates for this hardware specification, refer to the website at <http://www.Freescale.com>.

Contents

1. Overview	1
2. Features	3
3. Comparison with the MPC7455, MPC7445, MPC7450, MPC7451, and MPC7441	7
4. General Parameters	10
5. Electrical and Thermal Characteristics	10
6. Pin Assignments	33
7. Pinout Listings	35
8. Package Description	41
9. System Design Information	47
10. Document Revision History	61
11. Part Numbering and Marking	63

1 Overview

The MPC7457 is the fourth implementation of the fourth generation (G4) microprocessors from Freescale. The MPC7457 implements the full PowerPC 32-bit architecture and is targeted at networking and computing systems applications. The MPC7457 consists of a processor core, a 512-Kbyte L2, and an internal L3 tag and controller that support a glueless backside L3 cache through a dedicated high-bandwidth interface. The MPC7447 is identical to the MPC7457 except that it does not support the L3 cache interface.

Figure 1 shows a block diagram of the MPC7457. The core is a high-performance superscalar design supporting a double-precision floating-point unit and a SIMD multimedia unit.

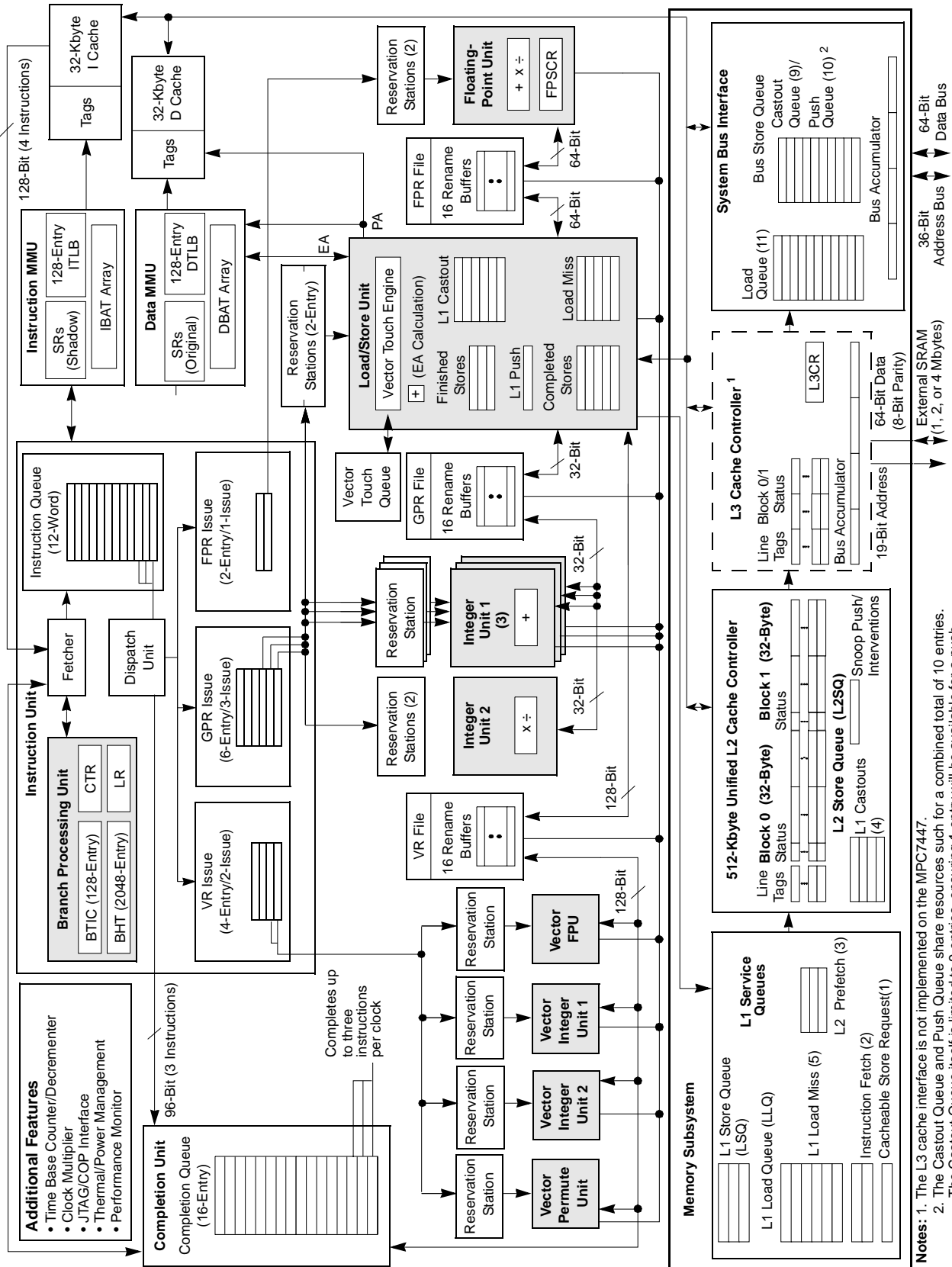


Figure 1. MPC7457 Block Diagram

Notes: 1. The L3 cache interface is not implemented on the MPC7447.
 2. The Castout Queue and Push Queue share resources such for a combined total of 10 entries. The Castout Queue itself is limited to 9 entries, ensuring 1 entry will be available for a push.

The memory storage subsystem supports the MPX bus protocol and a subset of the 60x bus protocol to main memory and other system resources. The L3 interface supports 1, 2, or 4 Mbytes of external SRAM for L3 cache and/or private memory data. For systems implementing 4 Mbytes of SRAM, a maximum of 2 Mbytes may be used as cache; the remaining 2 Mbytes must be private memory.

Note that the MPC7457 is a footprint-compatible, drop-in replacement in a MPC7455 application if the core power supply is 1.3 V.

2 Features

This section summarizes features of the MPC7457 implementation of the PowerPC architecture.

Major features of the MPC7457 are as follows:

- High-performance, superscalar microprocessor
 - As many as four instructions can be fetched from the instruction cache at a time.
 - As many as three instructions can be dispatched to the issue queues at a time.
 - As many as 12 instructions can be in the instruction queue (IQ).
 - As many as 16 instructions can be at some stage of execution simultaneously.
 - Single-cycle execution for most instructions
 - One instruction per clock cycle throughput for most instructions
 - Seven-stage pipeline control
- Eleven independent execution units and three register files
 - Branch processing unit (BPU) features static and dynamic branch prediction
 - 128-entry (32-set, four-way set associative) branch target instruction cache (BTIC), a cache of branch instructions that have been encountered in branch/loop code sequences. If a target instruction is in the BTIC, it is fetched into the instruction queue a cycle sooner than it can be made available from the instruction cache. Typically, a fetch that hits the BTIC provides the first four instructions in the target stream.
 - 2048-entry branch history (BHT) with 2 bits per entry for 4 levels of prediction—*not-taken*, *strongly not-taken*, *taken*, and *strongly taken*
 - Up to three outstanding speculative branches
 - Branch instructions that do not update the count register (CTR) or link register (LR) are often removed from the instruction stream.
 - Eight-entry link register stack to predict the target address of Branch Conditional to Link Register (**bclr**) instructions
 - Four integer units (IUs) that share 32 GPRs for integer operands
 - Three identical IUs (IU1a, IU1b, and IU1c) can execute all integer instructions except multiply, divide, and move to/from special-purpose register instructions
 - IU2 executes miscellaneous instructions including the CR logical operations, integer multiplication and division instructions, and move to/from special-purpose register instructions
 - Five-stage FPU and a 32-entry FPR file
 - Fully IEEE 754-1985 compliant FPU for both single- and double-precision operations
 - Supports non-IEEE mode for time-critical operations

Features

- Hardware support for denormalized numbers
- Thirty-two 64-bit FPRs for single- or double-precision operands
- Four vector units and 32-entry vector register file (VRs)
 - Vector permute unit (VPU)
 - Vector integer unit 1 (VIU1) handles short-latency AltiVec™ integer instructions, such as vector add instructions (for example, **vaddsbs**, **vaddshs**, and **vaddsws**)
 - Vector integer unit 2 (VIU2) handles longer-latency AltiVec integer instructions, such as vector multiply add instructions (for example, **vmhaddshs**, **vmhraddshs**, and **vmladduhm**)
 - Vector floating-point unit (VFPU)
- Three-stage load/store unit (LSU)
 - Supports integer, floating-point, and vector instruction load/store traffic
 - Four-entry vector touch queue (VTQ) supports all four architected AltiVec data stream operations
 - Three-cycle GPR and AltiVec load latency (byte, half-word, word, vector) with one-cycle throughput
 - Four-cycle FPR load latency (single, double) with one-cycle throughput
 - No additional delay for misaligned access within double-word boundary
 - Dedicated adder calculates effective addresses (EAs)
 - Supports store gathering
 - Performs alignment, normalization, and precision conversion for floating-point data
 - Executes cache control and TLB instructions
 - Performs alignment, zero padding, and sign extension for integer data
 - Supports hits under misses (multiple outstanding misses)
 - Supports both big- and little-endian modes, including misaligned little-endian accesses
- Three issue queues FIQ, VIQ, and GIQ can accept as many as one, two, and three instructions, respectively, in a cycle. Instruction dispatch requires the following:
 - Instructions can be dispatched only from the three lowest IQ entries—IQ0, IQ1, and IQ2
 - A maximum of three instructions can be dispatched to the issue queues per clock cycle
 - Space must be available in the CQ for an instruction to dispatch (this includes instructions that are assigned a space in the CQ but not in an issue queue)
- Rename buffers
 - 16 GPR rename buffers
 - 16 FPR rename buffers
 - 16 VR rename buffers
- Dispatch unit
 - Decode/dispatch stage fully decodes each instruction
- Completion unit
 - The completion unit retires an instruction from the 16-entry completion queue (CQ) when all instructions ahead of it have been completed, the instruction has finished execution, and no exceptions are pending.
 - Guarantees sequential programming model (precise exception model)
 - Monitors all dispatched instructions and retires them in order

- Tracks unresolved branches and flushes instructions after a mispredicted branch
- Retires as many as three instructions per clock cycle
- Separate on-chip L1 instruction and data caches (Harvard architecture)
 - 32-Kbyte, eight-way set associative instruction and data caches
 - Pseudo least recently used (PLRU) replacement algorithm
 - 32-byte (eight-word) L1 cache block
 - Physically indexed/physical tags
 - Cache write-back or write-through operation programmable on a per-page or per-block basis
 - Instruction cache can provide four instructions per clock cycle; data cache can provide four words per clock cycle
 - Caches can be disabled in software.
 - Caches can be locked in software.
 - MESI data cache coherency maintained in hardware
 - Separate copy of data cache tags for efficient snooping
 - Parity support on cache and tags
 - No snooping of instruction cache except for **icbi** instruction
 - Data cache supports AltiVec LRU and transient instructions
 - Critical double- and/or quad-word forwarding is performed as needed. Critical quad-word forwarding is used for AltiVec loads and instruction fetches. Other accesses use critical double-word forwarding.
- Level 2 (L2) cache interface
 - On-chip, 512-Kbyte, eight-way set associative unified instruction and data cache
 - Fully pipelined to provide 32 bytes per clock cycle to the L1 caches
 - A total nine-cycle load latency for an L1 data cache miss that hits in L2
 - PLRU replacement algorithm
 - Cache write-back or write-through operation programmable on a per-page or per-block basis
 - 64-byte, two-sectored line size
 - Parity support on cache
- Level 3 (L3) cache interface (not implemented on MPC7447)
 - Provides critical double-word forwarding to the requesting unit
 - Internal L3 cache controller and tags
 - External data SRAMs
 - Support for 1-, 2-, and 4-Mbyte (MB) total SRAM space
 - Support for 1- or 2-MB of cache space
 - Cache write-back or write-through operation programmable on a per-page or per-block basis
 - 64-byte (1-MB) or 128-byte (2-MB) sectored line size
 - Private memory capability for half (1 MB minimum) or all of the L3 SRAM space for a total of 1-, 2-, or 4-MB of private memory
 - Supports MSUG2 dual data rate (DDR) synchronous burst SRAMs, PB2 pipelined synchronous burst SRAMs, and pipelined (register-register) late write synchronous burst SRAMs
 - Supports parity on cache and tags

Features

- Configurable core-to-L3 frequency divisors
- 64-bit external L3 data bus sustains 64 bits per L3 clock cycle
- Separate memory management units (MMUs) for instructions and data
 - 52-bit virtual address; 32- or 36-bit physical address
 - Address translation for 4-Kbyte pages, variable-sized blocks, and 256-Mbyte segments
 - Memory programmable as write-back/write-through, caching-inhibited/caching-allowed, and memory coherency enforced/memory coherency not enforced on a page or block basis
 - Separate IBATs and DBATs (eight each) also defined as SPRs
 - Separate instruction and data translation lookaside buffers (TLBs)
 - Both TLBs are 128-entry, two-way set associative, and use LRU replacement algorithm
 - TLBs are hardware- or software-reloadable (that is, on a TLB miss a page table search is performed in hardware or by system software)
- Efficient data flow
 - Although the VR/LSU interface is 128 bits, the L1/L2/L3 bus interface allows up to 256 bits
 - The L1 data cache is fully pipelined to provide 128 bits/cycle to or from the VRs
 - L2 cache is fully pipelined to provide 256 bits per processor clock cycle to the L1 cache
 - As many as eight outstanding, out-of-order, cache misses are allowed between the L1 data cache and L2/L3 bus
 - As many as 16 out-of-order transactions can be present on the MPX bus
 - Store merging for multiple store misses to the same line. Only coherency action taken (address-only) for store misses merged to all 32 bytes of a cache block (no data tenure needed).
 - Three-entry finished store queue and five-entry completed store queue between the LSU and the L1 data cache
 - Separate additional queues for efficient buffering of outbound data (such as castouts and write-through stores) from the L1 data cache and L2 cache
- Multiprocessing support features include the following:
 - Hardware-enforced, MESI cache coherency protocols for data cache
 - Load/store with reservation instruction pair for atomic memory references, semaphores, and other multiprocessor operations
- Power and thermal management
 - 1.3-V processor core
 - The following three power-saving modes are available to the system:
 - Nap—Instruction fetching is halted. Only those clocks for the time base, decremter, and JTAG logic remain running. The part goes into the doze state to snoop memory operations on the bus and back to nap using a $\overline{QREQ}/\overline{QACK}$ processor-system handshake protocol.
 - Sleep—Power consumption is further reduced by disabling bus snooping, leaving only the PLL in a locked and running state. All internal functional units are disabled.
 - Deep sleep—When the part is in the sleep state, the system can disable the PLL. The system can then disable the SYSCLK source for greater system power savings. Power-on reset procedures for restarting and relocking the PLL must be followed on exiting the deep sleep state.

- Thermal management facility provides software-controllable thermal management. Thermal management is performed through the use of three supervisor-level registers and an MPC7457-specific thermal management exception.
- Instruction cache throttling provides control of instruction fetching to limit power consumption
- Performance monitor can be used to help debug system designs and improve software efficiency
- In-system testability and debugging features through JTAG boundary-scan capability
- Testability
 - LSSD scan design
 - IEEE 1149.1 JTAG interface
 - Array built-in self test (ABIST)—factory test only
- Reliability and serviceability
 - Parity checking on system bus and L3 cache bus
 - Parity checking on the L2 and L3 cache tag arrays

3 Comparison with the MPC7455, MPC7445, MPC7450, MPC7451, and MPC7441

Table 1 compares the key features of the MPC7457 with the key features of the earlier MPC7455, MPC7445, MPC7450, MPC7451, and MPC7441. To achieve a higher frequency, the number of logic levels per cycle is reduced. Also, to achieve this higher frequency, the pipeline of the MPC7457 is extended (compared to the MPC7400), while maintaining the same level of performance as measured by the number of instructions executed per cycle (IPC).

Table 1. Microarchitecture Comparison

Microarchitectural Specs	MPC7457/MPC7447	MPC7455/MPC7445	MPC7450/MPC7451/ MPC7441
Basic Pipeline Functions			
Logic inversions per cycle	18	18	18
Pipeline stages up to execute	5	5	5
Total pipeline stages (minimum)	7	7	7
Pipeline maximum instruction throughput	3 + Branch	3 + Branch	3 + Branch
Pipeline Resources			
Instruction buffer size	12	12	12
Completion buffer size	16	16	16
Renames (integer, float, vector)	16, 16, 16	16, 16, 16	16, 16, 16
Maximum Execution Throughput			
SFX	3	3	3
Vector	2 (any 2 of 4 units)	2 (any 2 of 4 units)	2 (any 2 of 4 units)
Scalar floating-point	1	1	1

Table 1. Microarchitecture Comparison (continued)

Microarchitectural Specs	MPC7457/MPC7447	MPC7455/MPC7445	MPC7450/MPC7451/ MPC7441
Out-of-Order Window Size in Execution Queues			
SFX integer units	1 entry × 3 queues	1 entry × 3 queues	1 entry × 3 queues
Vector units	In order, 4 queues	In order, 4 queues	In order, 4 queues
Scalar floating-point unit	In order	In order	In order
Branch Processing Resources			
Prediction structures	BTIC, BHT, link stack	BTIC, BHT, link stack	BTIC, BHT, link stack
BTIC size, associativity	128-entry, 4-way	128-entry, 4-way	128-entry, 4-way
BHT size	2K-entry	2K-entry	2K-entry
Link stack depth	8	8	8
Unresolved branches supported	3	3	3
Branch taken penalty (BTIC hit)	1	1	1
Minimum misprediction penalty	6	6	6
Execution Unit Timings (Latency-Throughput)			
Aligned load (integer, float, vector)	3-1, 4-1, 3-1	3-1, 4-1, 3-1	3-1, 4-1, 3-1
Misaligned load (integer, float, vector)	4-2, 5-2, 4-2	4-2, 5-2, 4-2	4-2, 5-2, 4-2
L1 miss, L2 hit latency	9 data/13 instruction	9 data/13 instruction	9 data/13 instruction
SFX (aDd Sub, Shift, Rot, Cmp, logicals)	1-1	1-1	1-1
Integer multiply (32 × 8, 32 × 16, 32 × 32)	3-1, 3-1, 4-2	3-1, 3-1, 4-2	3-1, 3-1, 4-2
Scalar float	5-1	5-1	5-1
VSFX (vector simple)	1-1	1-1	1-1
VCFX (vector complex)	4-1	4-1	4-1
VFPU (vector float)	4-1	4-1	4-1
VPER (vector permute)	2-1	2-1	2-1
MMUs			
TLBs (instruction and data)	128-entry, 2-way	128-entry, 2-way	128-entry, 2-way
Tablewalk mechanism	Hardware + software	Hardware + software	Hardware + software
Instruction BATs/data BATs	8/8	8/8	4/4
L1 I Cache/D Cache Features			
Size	32K/32K	32K/32K	32K/32K
Associativity	8-way	8-way	8-way
Locking granularity	Way	Way	Way

Table 1. Microarchitecture Comparison (continued)

Microarchitectural Specs	MPC7457/MPC7447	MPC7455/MPC7445	MPC7450/MPC7451/ MPC7441
Parity on I cache	Word	Word	Word
Parity on D cache	Byte	Byte	Byte
Number of D cache misses (load/store)	5/1	5/1	5/1
Data stream touch engines	4 streams	4 streams	4 streams
On-Chip Cache Features			
Cache level	L2	L2	L2
Size/associativity	512-Kbyte/8-way	256-Kbyte/8-way	256-Kbyte/8-way
Access width	256 bits	256 bits	256 bits
Number of 32-byte sectors/line	2	2	2
Parity	Byte	Byte	Byte
Off-Chip Cache Support ¹			
Cache level	L3	L3	L3
Total SRAM space supported	1 MB, 2MB, 4 MB ²	1 MB, 2 MB	1 MB, 2 MB
On-chip tag logical size (cache space)	1 MB, 2 MB	1 MB, 2 MB	1 MB, 2 MB
Associativity	8-way	8-way	8-way
Number of 32-byte sectors/line	2, 4	2, 4	2, 4
Off-Chip data SRAM support	MSUG2 DDR, LW, PB2	MSUG2 DDR, LW, PB2	MSUG2 DDR, LW, PB2
Data path width	64	64	64
Direct mapped SRAM sizes	1 MB, 2 MB, 4 MB	1 MB, 2 MB	1 MB, 2 MB
Parity	Byte	Byte	Byte

Notes:

1. Not implemented on MPC7447, MPC7445, or MPC7441.
2. The MPC7457 supports up to 4 MB of SRAM, of which a maximum of 2 MB can be configured as cache memory; the remaining 2 MB may be unused or configured as private memory.

4 General Parameters

The following list provides a summary of the general parameters of the MPC7457:

Technology	0.13 μm CMOS, nine-layer metal
Die size	9.1 mm \times 10.8 mm
Transistor count	58 million
Logic design	Fully-static
Packages	MPC7447: Surface mount 360 ceramic ball grid array (CBGA) MPC7457: Surface mount 483 ceramic ball grid array (CBGA)
Core power supply	1.3 V \pm 50 mV DC nominal
I/O power supply	1.8 V \pm 5% DC, or 2.5 V \pm 5% DC, or 1.5 V \pm 5% DC (L3 interface only, not implemented on MPC7447)

5 Electrical and Thermal Characteristics

This section provides the AC and DC electrical specifications and thermal characteristics for the MPC7457.

5.1 DC Electrical Characteristics

The tables in this section describe the MPC7457 DC electrical characteristics. [Table 2](#) provides the absolute maximum ratings.

Table 2. Absolute Maximum Ratings ¹

Characteristic		Symbol	Maximum Value	Unit	Notes
Core supply voltage		V_{DD}	-0.3 to 1.60	V	2
PLL supply voltage		AV_{DD}	-0.3 to 1.60	V	2
Processor bus supply voltage	BVSEL = 0	OV_{DD}	-0.3 to 1.95	V	3, 4
	BVSEL = $\overline{\text{HRESET}}$ or OV_{DD}	OV_{DD}	-0.3 to 2.7	V	3, 5
L3 bus supply voltage	L3VSEL = $\overline{\text{HRESET}}$	GV_{DD}	-0.3 to 1.65	V	3, 6
	L3VSEL = 0	GV_{DD}	-0.3 to 1.95	V	3, 7
	L3VSEL = $\overline{\text{HRESET}}$ or GV_{DD}	GV_{DD}	-0.3 to 2.7	V	3, 8
Input voltage	Processor bus	V_{in}	-0.3 to $OV_{DD} + 0.3$	V	9, 10
	L3 bus	V_{in}	-0.3 to $GV_{DD} + 0.3$	V	9, 10
	JTAG signals	V_{in}	-0.3 to $OV_{DD} + 0.3$	V	

Table 2. Absolute Maximum Ratings ¹ (continued)

Characteristic	Symbol	Maximum Value	Unit	Notes
Storage temperature range	T_{stg}	-55 to 150	°C	

Notes:

- Functional and tested operating conditions are given in Table 4. Absolute maximum ratings are stress ratings only, and functional operation at the maximums is not guaranteed. Stresses beyond those listed may affect device reliability or cause permanent damage to the device.
- Caution:** V_{DD}/AV_{DD} must not exceed OV_{DD}/GV_{DD} by more than 1.0 V during normal operation; this limit may be exceeded for a maximum of 20 ms during power-on reset and power-down sequences.
- Caution:** OV_{DD}/GV_{DD} must not exceed V_{DD}/AV_{DD} by more than 2.0 V during normal operation; this limit may be exceeded for a maximum of 20 ms during power-on reset and power-down sequences.
- BVSEL must be set to 0, such that the bus is in 1.8-V mode.
- BVSEL must be set to \overline{HRESET} or 1, such that the bus is in 2.5-V mode.
- L3VSEL must be set to \overline{HRESET} (inverse of HRESET), such that the bus is in 1.5-V mode.
- L3VSEL must be set to 0, such that the bus is in 1.8-V mode.
- L3VSEL must be set to HRESET or 1, such that the bus is in 2.5-V mode.
- Caution:** V_{in} must not exceed OV_{DD} or GV_{DD} by more than 0.3 V at any time including during power-on reset.
- V_{in} may overshoot/undershoot to a voltage and for a maximum duration as shown in Figure 2.

Figure 2 shows the undershoot and overshoot voltage on the MPC7457.

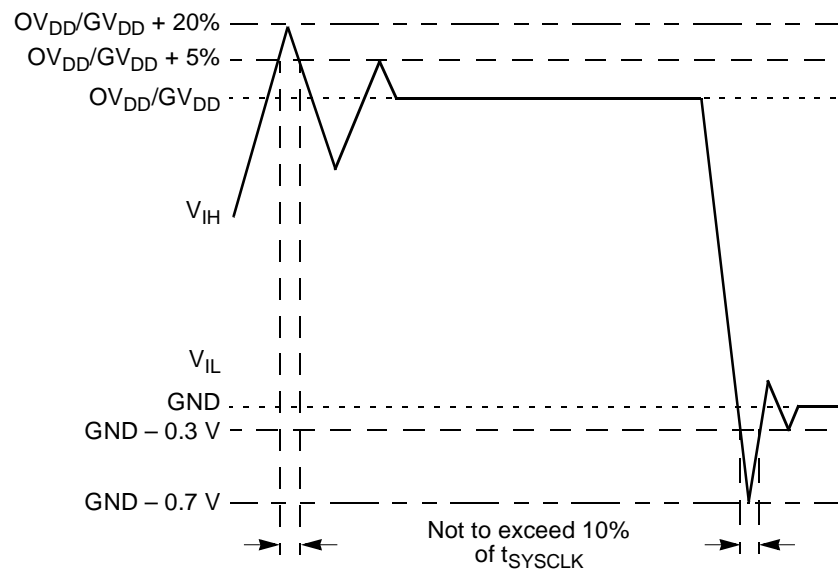


Figure 2. Overshoot/Undershoot Voltage

The MPC7457 provides several I/O voltages to support both compatibility with existing systems and migration to future systems. The MPC7457 core voltage must always be provided at nominal 1.3 V (see Table 4 for actual recommended core voltage). Voltage to the L3 I/Os and processor interface I/Os are provided through separate sets of supply pins and may be provided at the voltages shown in Table 3. The input voltage threshold for each bus is selected by sampling the state of the voltage select pins at the negation of the signal \overline{HRESET} . The output voltage will swing from GND to the maximum voltage applied to the OV_{DD} or GV_{DD} power pins.

Table 3. Input Threshold Voltage Setting

BVSEL Signal	Processor Bus Input Threshold is Relative to:	L3VSEL Signal ¹	L3 Bus Input Threshold is Relative to:	Notes
0	1.8 V	0	1.8 V	2, 3
$\overline{\text{HRESET}}$	Not Available	$\overline{\text{HRESET}}$	1.5 V	2, 4
$\overline{\text{HRESET}}$	2.5 V	$\overline{\text{HRESET}}$	2.5 V	2
1	2.5 V	1	2.5 V	2

Notes:

1. Not implemented on MPC7447.
2. **Caution:** The input threshold selection must agree with the OV_{DD}/GV_{DD} voltages supplied. See notes in [Table 2](#).
3. If used, pull-down resistors should be less than 250 Ω .
4. Applicable to L3 bus interface only. $\overline{\text{HRESET}}$ is the inverse of $\overline{\text{HRESET}}$.

[Table 4](#) provides the recommended operating conditions for the MPC7457.

Table 4. Recommended Operating Conditions ¹

Characteristic		Symbol	Recommended Value		Unit	Notes
			Min	Max		
Core supply voltage		V_{DD}	1.3 V \pm 50 mV		V	
PLL supply voltage		AV_{DD}	1.3 V \pm 50 mV		V	2
Processor bus supply voltage	BVSEL = 0	OV_{DD}	1.8 V \pm 5%		V	
	BVSEL = $\overline{\text{HRESET}}$ or OV_{DD}	OV_{DD}	2.5 V \pm 5%		V	
L3 bus supply voltage	L3VSEL = 0	GV_{DD}	1.8 V \pm 5%		V	
	L3VSEL = $\overline{\text{HRESET}}$ or GV_{DD}	GV_{DD}	2.5 V \pm 5%		V	
	L3VSEL = $\overline{\text{HRESET}}$	GV_{DD}	1.5 V \pm 5%		V	3
Input voltage	Processor bus	V_{in}	GND	OV_{DD}	V	
	L3 bus	V_{in}	GND	GV_{DD}	V	
	JTAG signals	V_{in}	GND	OV_{DD}	V	
Die-junction temperature		T_j	0	105	$^{\circ}\text{C}$	

Notes:

1. These are the recommended and tested operating conditions. Proper device operation outside of these conditions is not guaranteed.
2. This voltage is the input to the filter discussed in [Section 9.2, "PLL Power Supply Filtering,"](#) and not necessarily the voltage at the AV_{DD} pin, which may be reduced from V_{DD} by the filter.
3. $\overline{\text{HRESET}}$ is the inverse of $\overline{\text{HRESET}}$.

Table 5 provides the package thermal characteristics for the MPC7457.

Table 5. Package Thermal Characteristics ¹

Characteristic	Symbol	Value		Unit	Notes
		MPC7447	MPC7457		
Junction-to-ambient thermal resistance, natural convection	$R_{\theta JA}$	22	20	°C/W	2, 3
Junction-to-ambient thermal resistance, natural convection, four-layer (2s2p) board	$R_{\theta JMA}$	14	14	°C/W	2, 4
Junction-to-ambient thermal resistance, 200 ft/min airflow, single-layer (1s) board	$R_{\theta JMA}$	16	15	°C/W	2, 4
Junction-to-ambient thermal resistance, 200 ft/min airflow, four-layer (2s2p) board	$R_{\theta JMA}$	11	11	°C/W	2, 4
Junction-to-board thermal resistance	$R_{\theta JB}$	6	6	°C/W	5
Junction-to-case thermal resistance	$R_{\theta JC}$	<0.1	<0.1	°C/W	6
Coefficient of thermal expansion		6.8	6.8	ppm/°C	

Notes:

1. Refer to Section 9.8, "Thermal Management Information," for more details about thermal management.
2. Junction temperature is a function of on-chip power dissipation, package thermal resistance, mounting site (board) temperature, ambient temperature, airflow, power dissipation of other components on the board, and board thermal resistance.
3. Per SEMI G38-87 and JEDEC JESD51-2 with the single-layer board horizontal.
4. Per JEDEC JESD51-6 with the board horizontal.
5. Thermal resistance between the die and the printed-circuit board per JEDEC JESD51-8. Board temperature is measured on the top surface of the board near the package.
6. Thermal resistance between the die and the case top surface as measured by the cold plate method (MIL SPEC-883 Method 1012.1) with the calculated case temperature. The actual value of $R_{\theta JC}$ for the part is less than 0.1°C/W.

Table 6 provides the DC electrical characteristics for the MPC7457.

Table 6. DC Electrical Specifications

At recommended operating conditions. See Table 4.

Characteristic	Nominal Bus Voltage ¹	Symbol	Min	Max	Unit	Notes
Input high voltage (all inputs including SYSCLOCK)	1.5	V_{IH}	$GV_{DD} \times 0.65$	$GV_{DD} + 0.3$	V	2
	1.8		$OV_{DD}/GV_{DD} \times 0.65$	$OV_{DD}/GV_{DD} + 0.3$	V	
	2.5		1.7	$OV_{DD}/GV_{DD} + 0.3$	V	
Input low voltage (all inputs including SYSCLOCK)	1.5	V_{IL}	-0.3	$GV_{DD} \times 0.35$	V	2, 6
	1.8		-0.3	$OV_{DD}/GV_{DD} \times 0.35$	V	
	2.5		-0.3	0.7	V	
Input leakage current, $V_{in} = GV_{DD}/OV_{DD}$	—	I_{in}	—	30	μA	2, 3
High-impedance (off-state) leakage current, $V_{in} = GV_{DD}/OV_{DD}$	—	I_{TSI}	—	30	μA	2, 3, 4

Electrical and Thermal Characteristics

Table 6. DC Electrical Specifications (continued)

At recommended operating conditions. See [Table 4](#).

Characteristic		Nominal Bus Voltage ¹	Symbol	Min	Max	Unit	Notes
Output high voltage, $I_{OH} = -5$ mA		1.5	V_{OH}	$OV_{DD}/GV_{DD} - 0.45$	—	V	6
		1.8		$OV_{DD}/GV_{DD} - 0.45$	—	V	
		2.5		1.8	—	V	
Output low voltage, $I_{OL} = 5$ mA		1.5	V_{OL}	—	0.45	V	6
		1.8		—	0.45	V	
		2.5		—	0.6	V	
Capacitance, $V_{in} = 0$ V, $f = 1$ MHz	L3 interface	—	C_{in}	—	9.5	pF	5
	All other inputs			—	8.0		

Notes:

1. Nominal voltages; see [Table 4](#) for recommended operating conditions.
2. For processor bus signals, the reference is OV_{DD} while GV_{DD} is the reference for the L3 bus signals.
3. Excludes test signals and IEEE 1149.1 boundary scan (JTAG) signals.
4. The leakage is measured for nominal OV_{DD}/GV_{DD} and V_{DD} , or both OV_{DD}/GV_{DD} and V_{DD} must vary in the same direction (for example, both OV_{DD} and V_{DD} vary by either +5% or -5%).
5. Capacitance is periodically sampled rather than 100% tested.
6. Applicable to L3 bus interface only.

[Table 7](#) provides the power consumption for the MPC7457.

Table 7. Power Consumption for MPC7457

	Processor (CPU) Frequency				Unit	Notes
	867 MHz	1000 MHz	1200 MHz	1267 MHz		
Full-Power Mode						
Typical	14.8	15.8	17.5	18.3	W	1, 2
Maximum	21.0	22.0	24.2	25.6	W	1, 3
Nap Mode						
Typical	5.2	5.2	5.2	5.2	W	1, 2
Sleep Mode						
Typical	5.1	5.1	5.1	5.1	W	1, 2

Table 7. Power Consumption for MPC7457 (continued)

	Processor (CPU) Frequency				Unit	Notes
	867 MHz	1000 MHz	1200 MHz	1267 MHz		
Deep Sleep Mode (PLL Disabled)						
Typical	5.0	5.0	5.0	5.0	W	1, 2

Notes:

1. These values apply for all valid processor bus and L3 bus ratios. The values do not include I/O supply power (OV_{DD} and GV_{DD}) or PLL supply power (AV_{DD}). OV_{DD} and GV_{DD} power is system dependent, but is typically <5% of V_{DD} power. Worst case power consumption for AV_{DD} < 3 mW.
2. Typical power is an average value measured at the nominal recommended V_{DD} (see Table 4) and 65°C while running the Dhrystone 2.1 benchmark and achieving 2.3 Dhrystone MIPs/MHz.
3. Maximum power is the average measured at nominal V_{DD} and maximum operating junction temperature (see Table 4) while running an entirely cache-resident, contrived sequence of instructions which keep all the execution units maximally busy.
4. Doze mode is not a user-definable state; it is an intermediate state between full-power and either nap or sleep mode. As a result, power consumption for this mode is not tested.

5.2 AC Electrical Characteristics

This section provides the AC electrical characteristics for the MPC7457. After fabrication, functional parts are sorted by maximum processor core frequency as shown in Section 1.5.2.1, “Clock AC Specifications,” and tested for conformance to the AC specifications for that frequency. The processor core frequency is determined by the bus (SYSCLK) frequency and the settings of the PLL_CFG[0:4] signals. Parts are sold by maximum processor core frequency; see Section 1.11, “Ordering Information.”

5.2.1 Clock AC Specifications

Table 8 provides the clock AC timing specifications as defined in Figure 6 and represents the tested operating frequencies of the devices. The maximum system bus frequency, f_{SYSCLK} , given in Table 8 is considered a practical maximum in a typical single-processor system. The actual maximum SYSCLK frequency for any application of the MPC7457 will be a function of the AC timings of the MPC7457, the AC timings for the system controller, bus loading, printed-circuit board topology, trace lengths, and so forth, and may be less than the value given in Table 8. For information regarding the use of spread spectrum clock generators, see Section 9.1.3, “System Bus Clock (SYSCLK) and Spread Spectrum Sources.” PLL configuration and bus-to-core multiplier information is found in Section 9.1.1, “Core Clocks and PLL Configuration.”

Table 8. Clock AC Timing Specifications

At recommended operating conditions. See Table 4.

Characteristic	Symbol	Maximum Processor Core Frequency								Unit	Notes
		867 MHz		1000 MHz		1200 MHz		1267 MHz			
		Min	Max	Min	Max	Min	Max	Min	Max		
Processor frequency	f_{core}	600	867	600	1000	600	1200	600	1267	MHz	1
VCO frequency	f_{VCO}	1200	1733	1200	2000	1200	2400	1200	2534	MHz	1
SYSCLK frequency	f_{SYSCLK}	33	167	33	167	33	167	33	167	MHz	1, 2

Table 8. Clock AC Timing Specifications (continued)

At recommended operating conditions. See [Table 4](#).

Characteristic	Symbol	Maximum Processor Core Frequency								Unit	Notes
		867 MHz		1000 MHz		1200 MHz		1267 MHz			
		Min	Max	Min	Max	Min	Max	Min	Max		
SYSClk cycle time	t_{SYSClk}	6.0	30	6.0	30	6.0	30	6.0	30	ns	2
SYSClk rise and fall time	$t_{\text{KR}}, t_{\text{KF}}$	—	1.0	—	1.0	—	1.0	—	1.0	ns	3
SYSClk duty cycle measured at $OV_{\text{DD}}/2$	$t_{\text{KHKL}}/ t_{\text{SYSClk}}$	40	60	40	60	40	60	40	60	%	4
SYSClk cycle-to-cycle jitter		—	150	—	150	—	150	—	150	ps	5, 6
Internal PLL relock time		—	100	—	100	—	100	—	100	μs	7

Notes:

- Caution:** The SYSClk frequency and PLL_CFG[0:4] settings must be chosen such that the resulting SYSClk (bus) frequency, CPU (core) frequency, and PLL (VCO) frequency do not exceed their respective maximum or minimum operating frequencies. Refer to the PLL_CFG[0:4] signal description in Section 1.9.1, “PLL Configuration,” for valid PLL_CFG[0:4] settings.
- Assumes lightly-loaded, single-processor system; see [Section 5.2.1, “Clock AC Specifications”](#) for more information.
- Rise and fall times for the SYSClk input measured from 0.4 to 1.4 V.
- Timing is guaranteed by design and characterization.
- Guaranteed by design.
- The SYSClk driver’s closed loop jitter bandwidth should be less than 1.5 MHz at –3 dB.
- Relock timing is guaranteed by design and characterization. PLL-relock time is the maximum amount of time required for PLL lock after a stable V_{DD} and SYSClk are reached during the power-on reset sequence. This specification also applies when the PLL has been disabled and subsequently re-enabled during sleep mode. Also note that HRESET must be held asserted for a minimum of 255 bus clocks after the PLL-relock time during the power-on reset sequence.

[Figure 3](#) provides the SYSClk input timing diagram.

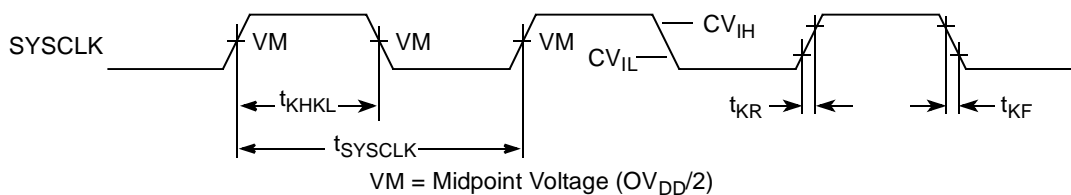


Figure 3. SYSClk Input Timing Diagram

5.2.2 Processor Bus AC Specifications

[Table 9](#) provides the processor bus AC timing specifications for the MPC7457 as defined in [Figure 4](#) and [Figure 5](#). Timing specifications for the L3 bus are provided in [Section 5.2.3, “L3 Clock AC Specifications.”](#)

Table 9. Processor Bus AC Timing Specifications ¹

At recommended operating conditions. See Table 4.

Parameter	Symbol ²	All Revisions and Speed Grades		Unit	Notes
		Min	Max		
Input setup times: A[0:35], AP[0:4] D[0:63], DP[0:7] AACK, ARTRY, \overline{BG} , $\overline{CKSTP_IN}$, \overline{DBG} , DTI[0:3], \overline{GBL} , TT[0:3], \overline{QACK} , \overline{TA} , TBEN, \overline{TEA} , \overline{TS} , EXT_QUAL, PMON_IN, SHD[0:1], BMODE[0:1], BVSEL, L3VSEL	t_{AVKH} t_{DVKH} t_{IVKH} t_{MVKH}	1.8 1.8 1.8 1.8	— — — —	ns	8
Input hold times: A[0:35], AP[0:4] D[0:63], DP[0:7] AACK, ARTRY, \overline{BG} , $\overline{CKSTP_IN}$, \overline{DBG} , DTI[0:3], \overline{GBL} , TT[0:3], \overline{QACK} , \overline{TA} , TBEN, \overline{TEA} , \overline{TS} , EXT_QUAL, PMON_IN, HD[0:1] BMODE[0:1], BVSEL, L3VSEL	t_{AXKH} t_{DXKH} t_{IXKH} t_{MXKH}	0 0 0 0	— — — —	ns	8
Output valid times: A[0:35], AP[0:4] D[0:63], DP[0:7] AACK, ARTRY, \overline{BR} , \overline{CI} , $\overline{CKSTP_IN}$, \overline{DRDY} , DTI[0:3], \overline{GBL} , \overline{HIT} , PMON_OUT, QREQ, \overline{TBST} , TSIZ[0:2], TT[0:3], \overline{TS} , SHD[0:1], \overline{WT}	t_{KHAV} t_{KHVDV} t_{KHOV}	— — —	2.0 2.0 2.0	ns	
Output hold times: A[0:35], AP[0:4] D[0:63], DP[0:7] AACK, ARTRY, \overline{BR} , \overline{CI} , $\overline{CKSTP_IN}$, \overline{DRDY} , DTI[0:3], \overline{GBL} , \overline{HIT} , PMON_OUT, QREQ, \overline{TBST} , TSIZ[0:2], TT[0:3], \overline{TS} , SHD[0:1], \overline{WT}	t_{KHAX} t_{KHDX} t_{KHOX}	0.5 0.5 0.5	— — —	ns	
SYSCLK to output enable	t_{KHOE}	0.5	—	ns	
SYSCLK to output high impedance (all except \overline{TS} , \overline{ARTRY} , SHD0, SHD1)	t_{KHOZ}	—	3.5	ns	
SYSCLK to \overline{TS} high impedance after precharge	t_{KHTSPZ}	—	1	t_{SYSCLK}	3, 4, 5
Maximum delay to \overline{ARTRY} / $\overline{SHD0}$ / $\overline{SHD1}$ precharge	t_{KHARP}	—	1	t_{SYSCLK}	3, 5 6, 7

Table 9. Processor Bus AC Timing Specifications ¹ (continued)

At recommended operating conditions. See [Table 4](#).

Parameter	Symbol ²	All Revisions and Speed Grades		Unit	Notes
		Min	Max		
SYSCLK to $\overline{\text{ARTRY}}/\overline{\text{SHD0}}/\overline{\text{SHD1}}$ high impedance after precharge	t_{KHARPZ}	—	2	t_{SYSCLK}	3, 5 6, 7

Notes:

1. All input specifications are measured from the midpoint of the signal in question to the midpoint of the rising edge of the input SYSCLK. All output specifications are measured from the midpoint of the rising edge of SYSCLK to the midpoint of the signal in question. All output timings assume a purely resistive 50-Ω load (see [Figure 4](#)). Input and output timings are measured at the pin; time-of-flight delays must be added for trace lengths, vias, and connectors in the system.
2. The symbology used for timing specifications herein follows the pattern of $t_{(\text{signal})(\text{state})(\text{reference})(\text{state})}$ for inputs and $t_{(\text{reference})(\text{state})(\text{signal})(\text{state})}$ for outputs. For example, t_{IVKH} symbolizes the time input signals (I) reach the valid state (V) relative to the SYSCLK reference (K) going to the high (H) state or input setup time. And t_{KHOV} symbolizes the time from SYSCLK(K) going high (H) until outputs (O) are valid (V) or output valid time. Input hold time can be read as the time that the input signal (I) went invalid (X) with respect to the rising clock edge (KH) (note the position of the reference and its state for inputs) and output hold time can be read as the time from the rising edge (KH) until the output went invalid (OX).
3. t_{SYSCLK} is the period of the external clock (SYSCLK) in ns. The numbers given in the table must be multiplied by the period of SYSCLK to compute the actual time duration (in ns) of the parameter in question.
4. According to the bus protocol, $\overline{\text{TS}}$ is driven only by the currently active bus master. It is asserted low then precharged high before returning to high impedance as shown in [Figure 6](#). The nominal precharge width for $\overline{\text{TS}}$ is $0.5 \times t_{\text{SYSCLK}}$; that is, less than the minimum t_{SYSCLK} period, to ensure that another master asserting $\overline{\text{TS}}$ on the following clock will not contend with the precharge. Output valid and output hold timing is tested for the signal asserted. Output valid time is tested for precharge. The high-impedance behavior is guaranteed by design.
5. Guaranteed by design and not tested.
6. According to the bus protocol, $\overline{\text{ARTRY}}$ can be driven by multiple bus masters through the clock period immediately following $\overline{\text{AACK}}$. Bus contention is not an issue because any master asserting $\overline{\text{ARTRY}}$ will be driving it low. Any master asserting it low in the first clock following $\overline{\text{AACK}}$ will then go to high impedance for one clock before precharging it high during the second cycle after the assertion of $\overline{\text{AACK}}$. The nominal precharge width for $\overline{\text{ARTRY}}$ is $1.0 t_{\text{SYSCLK}}$; that is, it should be high impedance as shown in [Figure 6](#) before the first opportunity for another master to assert $\overline{\text{ARTRY}}$. Output valid and output hold timing is tested for the signal asserted. The high-impedance behavior is guaranteed by design.
7. According to the MPX bus protocol, $\overline{\text{SHD0}}$ and $\overline{\text{SHD1}}$ can be driven by multiple bus masters beginning the cycle of $\overline{\text{TS}}$. Timing is the same as $\overline{\text{ARTRY}}$, that is, the signal is high impedance for a fraction of a cycle, then negated for up to an entire cycle (crossing a bus cycle boundary) before being three-stated again. The nominal precharge width for $\overline{\text{SHD0}}$ and $\overline{\text{SHD1}}$ is $1.0 t_{\text{SYSCLK}}$. The edges of the precharge vary depending on the programmed ratio of core to bus (PLL configurations).
8. $\text{BMODE}[0:1]$ and BVSEL are mode select inputs and are sampled before and after $\overline{\text{HRESET}}$ negation. These parameters represent the input setup and hold times for each sample. These values are guaranteed by design and not tested. These inputs must remain stable after the second sample. See [Figure 5](#) for sample timing.

[Figure 4](#) provides the AC test load for the MPC7457.

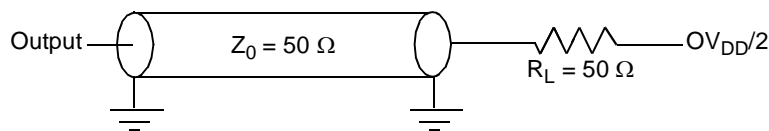


Figure 4. AC Test Load

Figure 5 provides the mode select input timing diagram for the MPC7457.

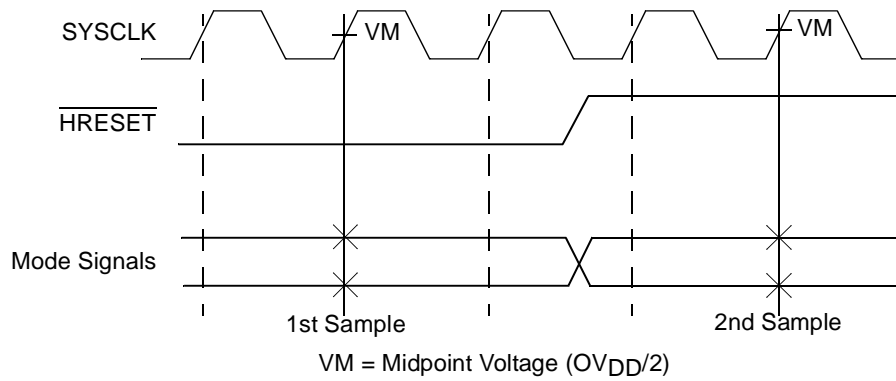


Figure 5. Mode Input Timing Diagram

Figure 6 provides the input/output timing diagram for the MPC7457.

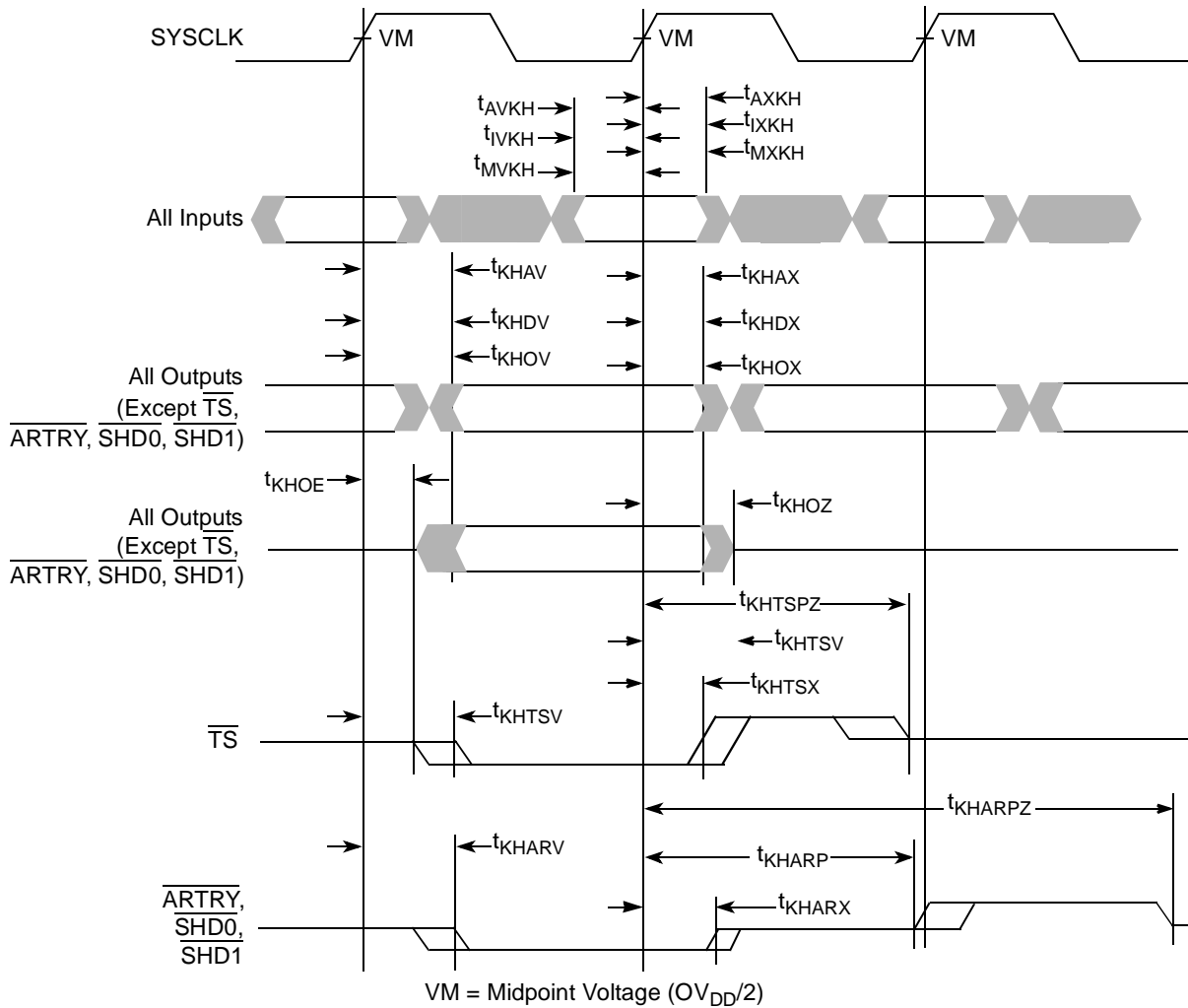


Figure 6. Input/Output Timing Diagram

5.2.3 L3 Clock AC Specifications

The L3_CLK frequency is programmed by the L3 configuration register core-to-L3 divisor ratio. See [Table 18](#) for example core and L3 frequencies at various divisors. [Table 10](#) provides the potential range of L3_CLK output AC timing specifications as defined in [Figure 7](#).

The maximum L3_CLK frequency is the core frequency divided by two. Given the high core frequencies available in the MPC7457, however, most SRAM designs will not be able to operate in this mode using current technology and, as a result, will select a greater core-to-L3 divisor to provide a longer L3_CLK period for read and write access to the L3 SRAMs. Therefore, the typical L3_CLK frequency shown in [Table 10](#) is considered to be the practical maximum in a typical system. The maximum L3_CLK frequency for any application of the MPC7457 will be a function of the AC timings of the MPC7457, the AC timings for the SRAM, bus loading, and printed-circuit board trace length, and may be greater or less than the value given in [Table 10](#). Note that SYSCLK input jitter and L3_CLK[0:1] output jitter are already comprehended in the L3 bus AC timing specifications and do not need to be separately accounted for in an L3 AC timing analysis. Clock skews, where applicable, do need to be accounted for in an AC timing analysis.

Freescale is similarly limited by system constraints and cannot perform tests of the L3 interface on a socketed part on a functional tester at the maximum frequencies of [Table 10](#). Therefore, functional operation and AC timing information are tested at core-to-L3 divisors which result in L3 frequencies at 250 MHz or lower.

Table 10. L3_CLK Output AC Timing Specifications

At recommended operating conditions. See [Table 4](#).

Parameter	Symbol	Device Revision (L3 I/O Voltage) ⁶						Unit	Notes
		Rev 1.1. (All I/O Modes) Rev 1.2 (1.5-V I/O Mode)			Rev 1.2 (1.8-, 2.5-V I/O Modes)				
		Min	Typ	Max	Min	Typ	Max		
L3 clock frequency	f _{L3_CLK}	—	200	—	—	250	—	MHz	1
L3 clock cycle time	t _{L3_CLK}	—	5.0	—	—	4.0	—	ns	1
L3 clock duty cycle	t _{CHCL} /t _{L3_CLK}	—	50	—	—	50	—	%	2
L3 clock output-to-output skew (L3_CLK0 to L3_CLK1)	t _{L3CSKW1}	—	—	100	—	—	100	ps	3
L3 clock output-to-output skew (L3_CLK[0:1] to L3_ECHO_CLK[1,3])	t _{L3CSKW2}	—	—	100	—	—	100	ps	4

Table 10. L3_CLK Output AC Timing Specifications (continued)

At recommended operating conditions. See [Table 4](#).

Parameter	Symbol	Device Revision (L3 I/O Voltage) ⁶						Unit	Notes
		Rev 1.1. (All I/O Modes) Rev 1.2 (1.5-V I/O Mode)			Rev 1.2 (1.8-, 2.5-V I/O Modes)				
		Min	Typ	Max	Min	Typ	Max		
L3 clock jitter		—	—	± 75	—	—	± 75	ps	5

Notes:

1. The maximum L3 clock frequency (and minimum L3 clock period) will be system dependent. See [Section 5.2.3, “L3 Clock AC Specifications,”](#) for an explanation that this maximum frequency is not functionally tested at speed by Freescale. The minimum L3 clock frequency and period are f_{SYSCLK} and t_{SYSCLK} , respectively.
2. The nominal duty cycle of the L3 output clocks is 50% measured at midpoint voltage.
3. Maximum possible skew between L3_CLK0 and L3_CLK1. This parameter is critical to the address and control signals which are common to both SRAM chips in the L3.
4. Maximum possible skew between L3_CLK0 and L3_ECHO_CLK1 or between L3_CLK1 and L3_ECHO_CLK3 for PB2 or Late Write SRAM. This parameter is critical to the read data signals because the processor uses the feedback loop to latch data driven from the SRAM, each of which drives data based on L3_CLK0 or L3_CLK1.
5. Guaranteed by design and not tested. The input jitter on SYSCLK affects L3 output clocks and the L3 address, data, and control signals equally and, therefore, is already comprehended in the AC timing and does not have to be considered in the L3 timing analysis. The clock-to-clock jitter shown here is uncertainty in the internal clock period caused by supply voltage noise or thermal effects. This is also comprehended in the AC timing specifications and need not be considered in the L3 timing analysis.
6. L3 I/O voltage mode must be configured by L3VSEL as described in [Table 3](#), and voltage supplied at GV_{DD} must match mode selected as specified in [Table 4](#). See [Table 23](#) for revision level information and part marking.

The L3_CLK timing diagram is shown in [Figure 7](#).

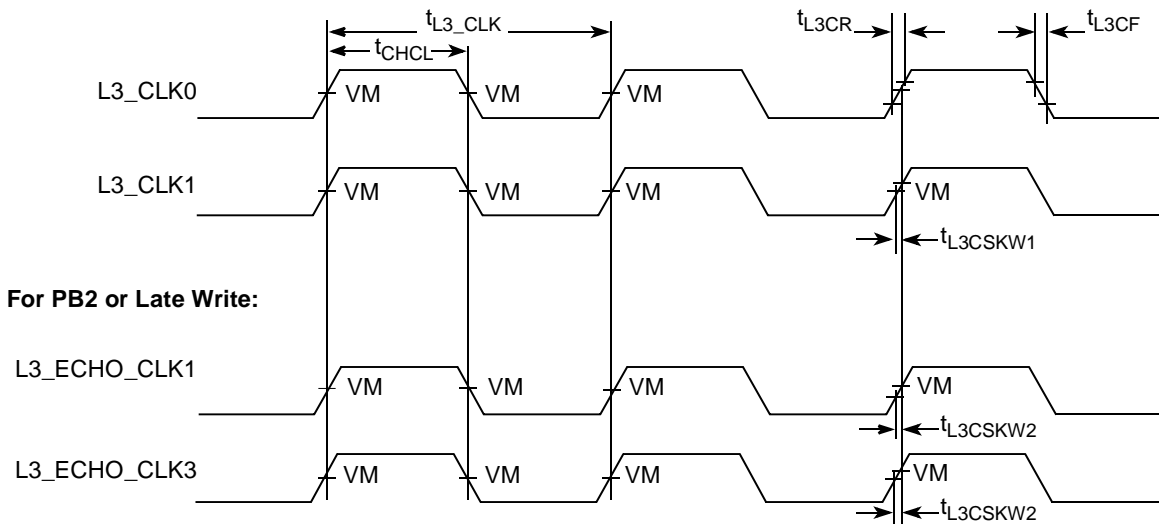


Figure 7. L3_CLK_OUT Output Timing Diagram

5.2.4 L3 Bus AC Specifications

The MPC7457 L3 interface supports three different types of SRAM: source-synchronous, double data rate (DDR) MSUG2 SRAM, Late Write SRAMs, and pipeline burst (PB2) SRAMs. Each requires a different protocol on the L3 interface and a different routing of the L3 clock signals. The type of SRAM is programmed in L3CR[22:23] and the MPC7457 then follows the appropriate protocol for that type. The designer must connect and route the L3 signals appropriately for each type of SRAM. Following are some observations about the L3 interface.

- The routing for the point-to-point signals (L3_CLK[0:1], L3DATA[0:63], L3DP[0:7], and L3_ECHO_CLK[0:3]) to a particular SRAM must be delay matched.
- For 1-Mbyte of SRAM, use L3_ADDR[16:0] (L3_ADDR[0] is LSB)
- For 2-Mbyte of SRAM, use L3_ADDR[17:0] (L3_ADDR[0] is LSB)
- For 4-Mbyte of SRAM, use L3_ADDR[18:0] (L3_ADDR[0] is LSB)
- No pull-up resistors are required for the L3 interface
- For high-speed operations, L3 interface address and control signals should be a ‘T’ with minimal stubs to the two loads; data and clock signals should be point-to-point to their single load. [Figure 8](#) shows the AC test load for the L3 interface.

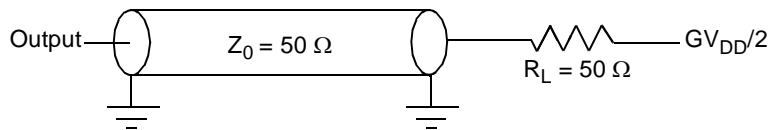


Figure 8. AC Test Load for the L3 Interface

In general, if routing is short, delay-matched, and designed for incident wave reception and minimal reflection, there is a high probability that the AC timing of the MPC7457 L3 interface will meet the maximum frequency operation of appropriately chosen SRAMs. This is despite the pessimistic, guard-banded AC specifications (see [Table 12](#), [Table 13](#), and [Table 14](#)), the limitations of functional testers described in [Section 5.2.3, “L3 Clock AC Specifications,”](#) and the uncertainty of clocks and signals which inevitably make worst-case critical path timing analysis pessimistic.

More specifically, certain signals within groups should be delay-matched with others in the same group while intergroup routing is less critical. Only the address and control signals are common to both SRAMs and additional timing margin is available for these signals. The double-clocked data signals are grouped with individual clocks as shown in [Figure 9](#) or [Figure 11](#), depending on the type of SRAM. For example, for the MSUG2 DDR SRAM (see [Figure 9](#)); L3DATA[0:31], L3DP[0:3], and L3_CLK[0] form a closely coupled group of outputs from the MPC7457; while L3DATA[0:15], L3DP[0:1], and L3_ECHO_CLK[0] form a closely coupled group of inputs.

The *MPC7450 RISC Microprocessor Family User’s Manual* refers to logical settings called ‘sample points’ used in the synchronization of reads from the receive FIFO. The computation of the correct value for this setting is system-dependent and is described in the *MPC7450 RISC Microprocessor Family User’s Manual*. Three specifications are used in this calculation and are given in [Table 11](#). It is essential that all three specifications are included in the calculations to determine the sample points, as incorrect settings can result in errors and unpredictable behavior. For more information, see the *MPC7450 RISC Microprocessor Family User’s Manual*.

Table 11. Sample Points Calculation Parameters

Parameter	Symbol	Max	Unit	Notes
Delay from processor clock to internal_L3_CLK	t_{AC}	3/4	t_{L3_CLK}	1
Delay from internal_L3_CLK to L3_CLK[n] output pins	t_{CO}	3	ns	2
Delay from L3_ECHO_CLK[n] to receive latch	t_{ECI}	3	ns	3

Notes:

1. This specification describes a logical offset between the internal clock edge used to launch the L3 address and control signals (this clock edge is phase-aligned with the processor clock edge) and the internal clock edge used to launch the L3_CLK[n] signals. With proper board routing, this offset ensures that the L3_CLK[n] edge will arrive at the SRAM within a valid address window and provide adequate setup and hold time. This offset is reflected in the L3 bus interface AC timing specifications, but must also be separately accounted for in the calculation of sample points and, thus, is specified here.
2. This specification is the delay from a rising or falling edge on the internal_L3_CLK signal to the corresponding rising or falling edge at the L3CLK[n] pins.
3. This specification is the delay from a rising or falling edge of L3_ECHO_CLK[n] to data valid and ready to be sampled from the FIFO.

5.2.4.1 Effects of L3OHCR Settings on L3 Bus AC Specifications

The AC timing of the L3 interface can be adjusted using the L3 Output Hold Control Register (L3OCHR). Each field controls the timing for a group of signals. The AC timing specifications presented herein represent the AC timing when the register contains the default value of 0x0000_0000. Incrementing a field delays the associated signals, increasing the output valid time and hold time of the affected signals. In the special case of delaying an L3_CLK signal, the net effect is to decrease the output valid and output hold times of all signals being latched relative to that clock signal. The amount of delay added is summarized in Table 12. Note that these settings affect output timing parameters only and do not impact input timing parameters of the L3 bus in any way.

Table 12. Effect of L3OHCR Settings on L3 Bus AC Timing

At recommended operating conditions. See Table 4.

Field Name ¹	Affected Signals	Value	Output Valid Time		Output Hold Time		Unit	Notes	
			Parameter Symbol ²	Change ³	Parameter Symbol ²	Change ³			
L3AOH	L3_ADDR[18:0], L3_CNTL[0:1]	0b00	t_{L3CHOV}	0	t_{L3CHOX}	0	ps	4	
		0b01		+50		+50			
		0b10		+100		+100			
		0b11		+150		+150			
L3CLK _n _OH	All signals latched by SRAM connected to L3_CLK _n	0b000	t_{L3CHOV} ,	0	t_{L3CHOX} ,	0	ps	4	
		0b001	t_{L3CHDV} ,	- 50	t_{L3CHDX} ,	- 50			5
		0b010	t_{L3CLDV}	- 100	t_{L3CLDX} ,	- 100			
		0b011		- 150		- 150			
		0b100		- 200		- 200			
		0b101		- 250		- 250			
		0b110		- 300		- 300			
		0b111		- 350		- 350			

Table 12. Effect of L3OHCR Settings on L3 Bus AC Timing (continued)

At recommended operating conditions. See [Table 4](#).

Field Name ¹	Affected Signals	Value	Output Valid Time		Output Hold Time		Unit	Notes
			Parameter Symbol ²	Change ³	Parameter Symbol ²	Change ³		
L3DOHn	L3_DATA[n:n+7], L3_DP[n/8]	0b000	t _{L3CHDV} , t _{L3CLDV}	0	t _{L3CHDX} , t _{L3CLDX} ,	0	ps	4
		0b001		+ 50		+ 50		
		0b010		+ 100		+ 100		
		0b011		+ 150		+ 150		
		0b100		+ 200		+ 200		
		0b101		+ 250		+ 250		
		0b111		+ 300		+ 300		
		0b111		+ 350		+ 350		

Notes:

1. See the *MPC7450 RISC Microprocessor Family User's Manual* for specific information regarding L3OHCR.
2. See [Table 13](#) and [Table 14](#) for more information.
3. Approximate delay verified by simulation; not tested or characterized.
4. Default value.
5. Increasing values of L3CLKn_OH delay the L3_CLKn signal, effectively decreasing the output valid and output hold times of all signals latched relative to that clock signal by the SRAM; see [Figure 9](#) and [Figure 11](#).

5.2.4.2 L3 Bus AC Specifications for DDR MSUG2 SRAMs

When using DDR MSUG2 SRAMs at the L3 interface, the parts should be connected as shown in [Figure 9](#). Outputs from the MPC7457 are actually launched on the edges of an internal clock phase-aligned to SYSCLK (adjusted for core and L3 frequency divisors). L3_CLK0 and L3_CLK1 are this internal clock output with 90° phase delay, so outputs are shown synchronous to L3_CLK0 and L3_CLK1. Output valid times are typically negative when referenced to L3_CLKn because the data is launched one-quarter period before L3_CLKn to provide adequate setup time at the SRAM after the delay-matched address, control, data, and L3_CLKn signals have propagated across the printed-wiring board.

Inputs to the MPC7457 are source-synchronous with the CQ clock generated by the DDR MSUG2 SRAMs. These CQ clocks are received on the L3_ECHO_CLKn inputs of the MPC7457. An internal circuit delays the incoming L3_ECHO_CLKn signal such that it is positioned within the valid data window at the internal receiving latches. This delayed clock is used to capture the data into these latches which comprise the receive FIFO. This clock is asynchronous to all other processor clocks. This latched data is subsequently read out of the FIFO synchronously to the processor clock. The time between writing and reading the data is set by the using the sample point settings defined in the L3CR register.

[Table 13](#) provides the L3 bus interface AC timing specifications for the configuration as shown in [Figure 9](#), assuming the timing relationships shown in [Figure 10](#) and the loading shown in [Figure 8](#).

Table 13. L3 Bus Interface AC Timing Specifications for MSUG2At recommended operating conditions. See [Table 4](#).

Parameter	Symbol	Device Revision (L3 I/O Voltage) ⁹				Unit	Notes
		Rev 1.1. (All I/O Modes) Rev 1.2 (1.5-V I/O Mode)		Rev 1.2 (1.8-, 2.5-V I/O Modes)			
		Min	Max	Min	Max		
L3_CLK rise and fall time	t_{L3CR}, t_{L3CF}	—	0.75	—	0.75	ns	1
Setup times: Data and parity	t_{L3DVEH}, t_{L3DVEL}	$(-t_{L3CLK/4} + 0.90)$	—	$(-t_{L3CLK/4} + 0.70)$	—	ns	2, 3, 4
Input hold times: Data and parity	t_{L3DXEH}, t_{L3DXEL}	$(t_{L3CLK/4} + 0.85)$	—	$(t_{L3CLK/4} + 0.70)$	—	ns	2, 4
Valid times: Data and parity	t_{L3CHDV}, t_{L3CLDV}	—	$(-t_{L3CLK/4} + 0.60)$	—	$(-t_{L3CLK/4} + 0.50)$	ns	5, 6, 7, 8
Valid times: All other outputs	t_{L3CHOV}	—	$(t_{L3CLK/4} + 0.65)$	—	$(t_{L3CLK/4} + 0.65)$	ns	5, 7, 8
Output hold times: Data and parity	t_{L3CHDX}, t_{L3CLDX}	$(t_{L3CLK/4} - 0.60)$	—	$(t_{L3CLK/4} - 0.50)$	—	ns	5, 6, 7, 8
Output hold times: All other outputs	t_{L3CHOX}	$(t_{L3CLK/4} - 0.50)$	—	$(t_{L3CLK/4} - 0.50)$	—	ns	5, 7, 8
L3_CLK to high impedance: Data and parity	t_{L3CLDZ}	—	$(-t_{L3CLK/4} + 0.60)$	—	$(-t_{L3CLK/4} + 0.60)$	ns	
L3_CLK to high impedance: All other outputs	t_{L3CHOZ}	—	$(t_{L3CLK/4} + 0.65)$	—	$(t_{L3CLK/4} + 0.65)$	ns	

Notes:

- Rise and fall times for the L3_CLK output are measured from 20% to 80% of GV_{DD} .
- For DDR, all input specifications are measured from the midpoint of the signal in question to the midpoint voltage of the rising or falling edge of the input L3_ECHO_CLK n (see [Figure 10](#)). Input timings are measured at the pins.
- For DDR, the input data will typically follow the edge of L3_ECHO_CLK n as shown in [Figure 10](#). For consistency with other input setup time specifications, this will be treated as negative input setup time.
- $t_{L3_CLK/4}$ is one-fourth the period of L3_CLK n . This parameter indicates that the MPC7457 can latch an input signal that is valid for only a short time before and a short time after the midpoint between the rising and falling (or falling and rising) edges of L3_ECHO_CLK n at any frequency.
- All output specifications are measured from the midpoint voltage of the rising (or for DDR write data, also the falling) edge of L3_CLK to the midpoint of the signal in question. The output timings are measured at the pins. All output timings assume a purely resistive 50- Ω load (see [Figure 8](#)).
- For DDR, the output data will typically lead the edge of L3_CLK n as shown in [Figure 10](#). For consistency with other output valid time specifications, this will be treated as negative output valid time.
- $t_{L3_CLK/4}$ is one-fourth the period of L3_CLK n . This parameter indicates that the specified output signal is actually launched by an internal clock delayed in phase by 90°. Therefore, there is a frequency component to the output valid and output hold times such that the specified output signal will be valid for approximately one L3_CLK period starting three-fourths of a clock before the edge on which the SRAM will sample it and ending one-fourth of a clock period after the edge it will be sampled.
- Assumes default value of L3OHCR. See [Section 5.2.4.1, "Effects of L3OHCR Settings on L3 Bus AC Specifications,"](#) for more information.
- L3 I/O voltage mode must be configured by L3VSEL as described in [Table 3](#), and voltage supplied at GV_{DD} must match mode selected as specified in [Table 4](#). See [Table 23](#) for revision level information and part marking.

Figure 9 shows the typical connection diagram for the MPC7457 interfaced to MSUG2 DDR SRAMs.

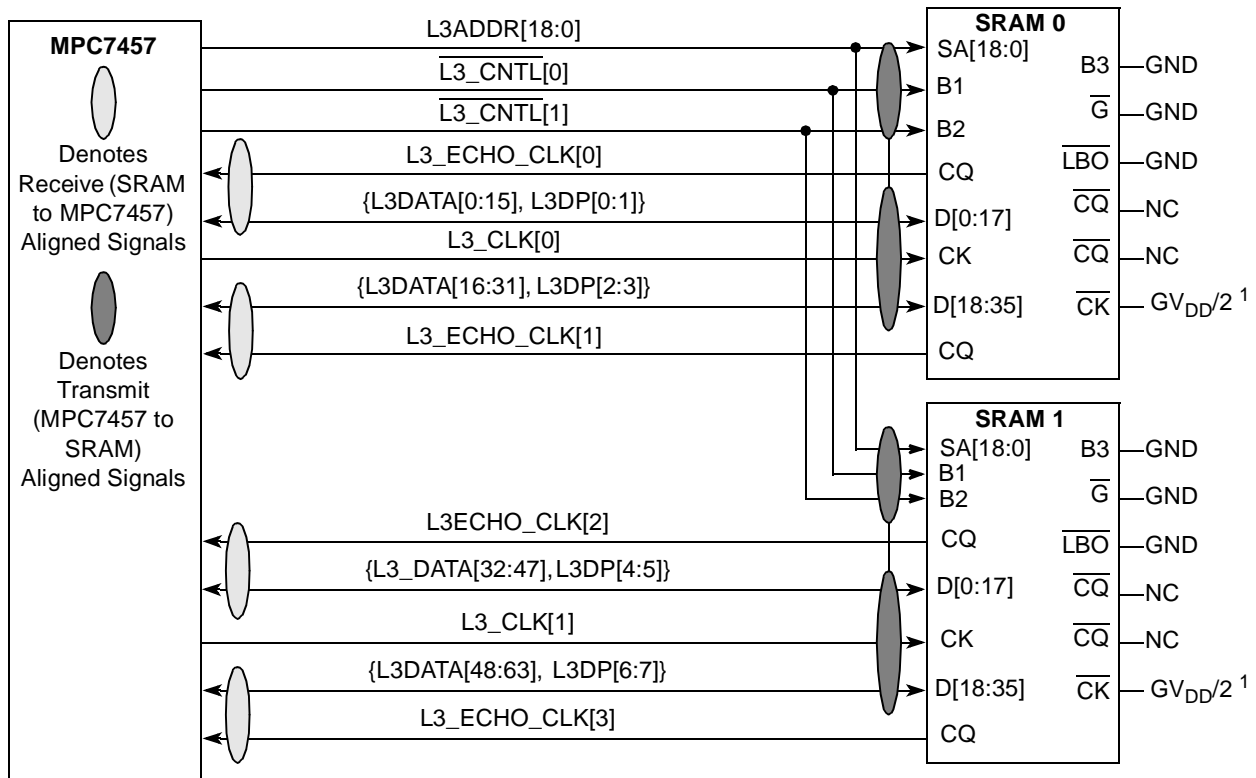


Figure 9. Typical Source Synchronous 4-Mbyte L3 Cache DDR Interface

Figure 10 shows the L3 bus timing diagrams for the MPC7457 interfaced to MSUG2 SRAMs.

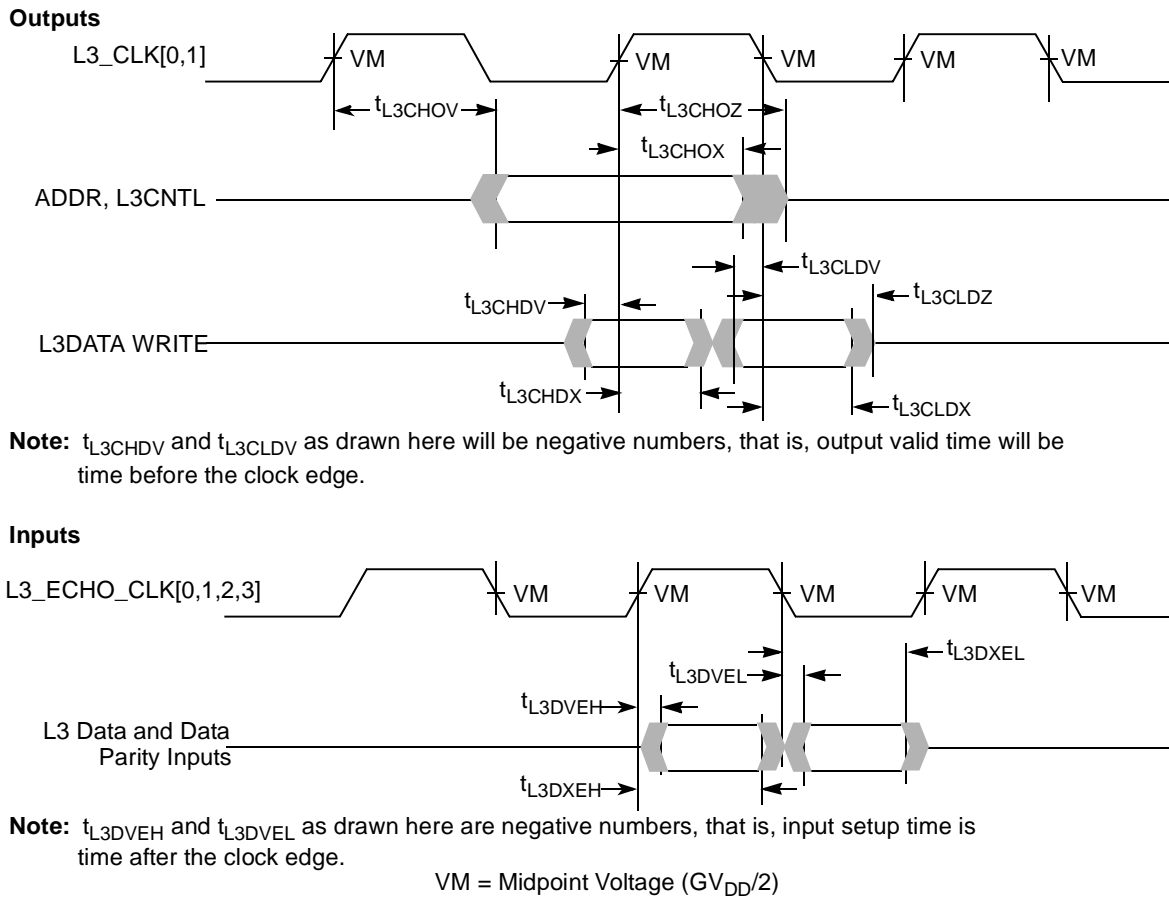


Figure 10. L3 Bus Timing Diagrams for L3 Cache DDR SRAMs

5.2.4.3 L3 Bus AC Specifications for PB2 and Late Write SRAMs

When using PB2 or Late Write SRAMs at the L3 interface, the parts should be connected as shown in Figure 11. These SRAMs are synchronous to the MPC7457; one $L3_CLK_n$ signal is output to each SRAM to latch address, control, and write data. Read data is launched by the SRAM synchronous to the delayed $L3_CLK_n$ signal it received. The MPC7457 needs a copy of that delayed clock which launched the SRAM read data to know when the returning data will be valid. Therefore, $L3_ECHO_CLK1$ and $L3_ECHO_CLK3$ must be routed halfway to the SRAMs and returned to the MPC7457 inputs $L3_ECHO_CLK0$ and $L3_ECHO_CLK2$, respectively. Thus, $L3_ECHO_CLK0$ and $L3_ECHO_CLK2$ are phase-aligned with the input clock received at the SRAMs. The MPC7457 will latch the incoming data on the rising edge of $L3_ECHO_CLK0$ and $L3_ECHO_CLK2$.

Table 14 provides the L3 bus interface AC timing specifications for the configuration shown in Figure 11, assuming the timing relationships of Figure 12 and the loading of Figure 8.

Electrical and Thermal Characteristics

Table 14. L3 Bus Interface AC Timing Specifications for PB2 and Late Write SRAMs

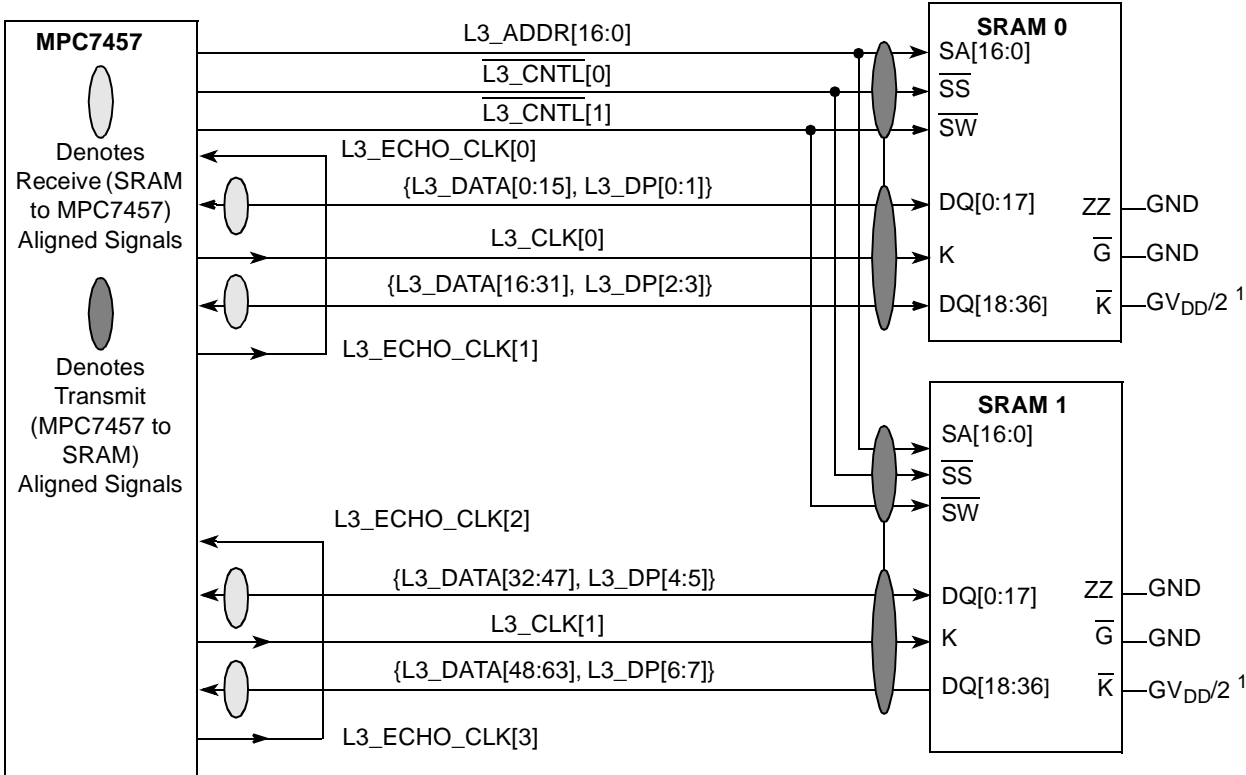
At recommended operating conditions. See [Table 4](#).

Parameter	Symbol	All Revisions and L3 I/O Voltage Modes		Unit	Notes
		Min	Max		
L3_CLK rise and fall time	t_{L3CR}, t_{L3CF}	—	0.75	ns	1, 2
Setup times: Data and parity	t_{L3DVEH}	0.1	—	ns	2, 3
Input hold times: Data and parity	t_{L3DXEH}	—	0.7	ns	2, 3
Valid times: Data and parity	t_{L3CHDV}	—	2.5	ns	2, 4, 5
Valid times: All other outputs	t_{L3CHOV}	—	1.8	ns	5
Output hold times: Data and parity	t_{L3CHDX}	1.4	—	ns	2, 4, 5
Output hold times: All other outputs	t_{L3CHOX}	1.0	—	ns	2, 5
L3_CLK to high impedance: Data and parity	t_{L3CHDZ}	—	3.0	ns	2
L3_CLK to high impedance: All other outputs	t_{L3CHOZ}	—	3.0	ns	2

Notes:

1. Rise and fall times for the L3_CLK output are measured from 20% to 80% of GV_{DD} .
2. Timing behavior and characterization are currently being evaluated.
3. All input specifications are measured from the midpoint of the signal in question to the midpoint voltage of the rising edge of the input L3_ECHO_CLK n (see [Figure 10](#)). Input timings are measured at the pins.
4. All output specifications are measured from the midpoint voltage of the rising edge of L3_CLK n to the midpoint of the signal in question. The output timings are measured at the pins. All output timings assume a purely resistive 50- Ω load (see [Figure 10](#)).
5. Assumes default value of L3OHCR. See [Section 5.2.4.1, “Effects of L3OHCR Settings on L3 Bus AC Specifications,”](#) for more information.

Figure 11 shows the typical connection diagram for the MPC7457 interfaced to PB2 SRAMs or Late Write SRAMs.



Note:

- 1. Or as recommended by SRAM manufacturer for single-ended clocking.

Figure 11. Typical Synchronous 1-MByte L3 Cache Late Write or PB2 Interface

Downloaded from Elcodis.com electronic components distributor

Electrical and Thermal Characteristics

Figure 12 shows the L3 bus timing diagrams for the MPC7457 interfaced to PB2 or Late Write SRAMs.

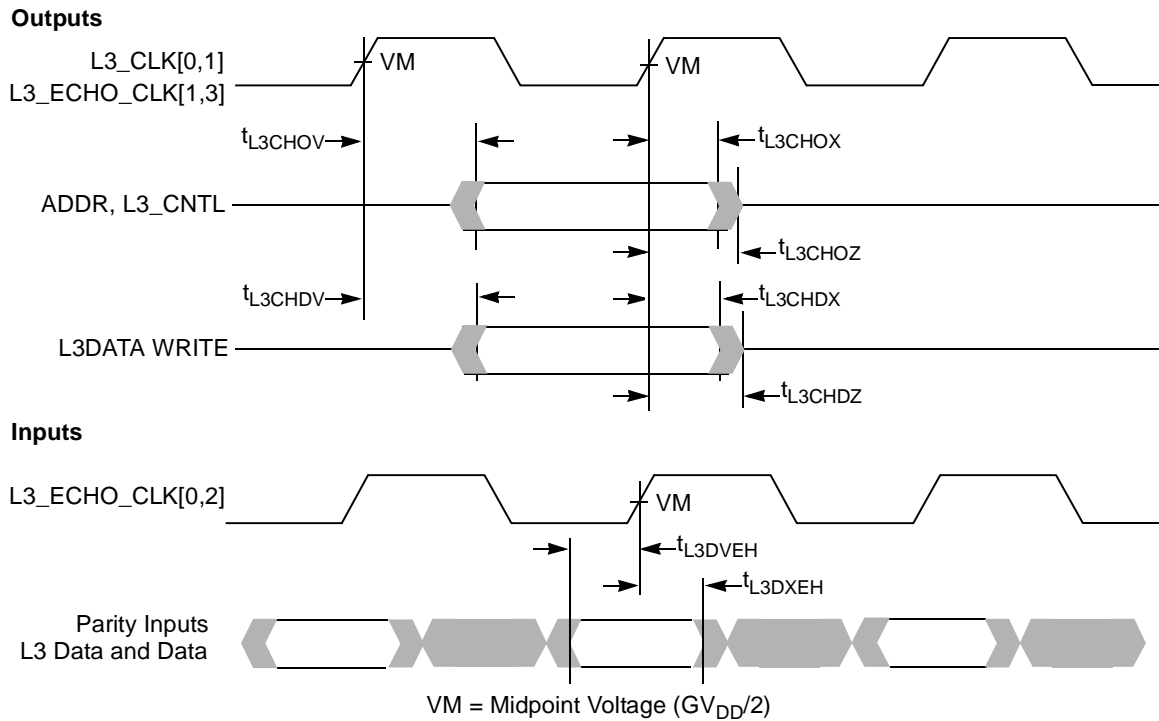


Figure 12. L3 Bus Timing Diagrams for Late Write or PB2 SRAMs

5.2.5 IEEE 1149.1 AC Timing Specifications

Table 15 provides the IEEE 1149.1 (JTAG) AC timing specifications as defined in Figure 14 through Figure 17.

Table 15. JTAG AC Timing Specifications (Independent of SYSCLK) ¹

At recommended operating conditions. See Table 4.

Parameter	Symbol	Min	Max	Unit	Notes
TCK frequency of operation	f_{TCLK}	0	33.3	MHz	
TCK cycle time	t_{TCLK}	30	—	ns	
TCK clock pulse width measured at 1.4 V	t_{JHJL}	15	—	ns	
TCK rise and fall times	t_{JR} and t_{JF}	0	2	ns	
\overline{TRST} assert time	t_{TRST}	25	—	ns	2
Input setup times: Boundary-scan data TMS, TDI	t_{DVJH} t_{IVJH}	4 0	— —	ns	3
Input hold times: Boundary-scan data TMS, TDI	t_{DXJH} t_{IXJH}	20 25	— —	ns	3
Valid times: Boundary-scan data TDO	t_{JLDV} t_{JLOV}	4 4	20 25	ns	4

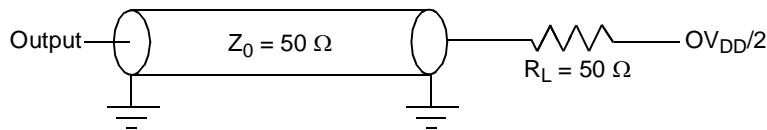
Table 15. JTAG AC Timing Specifications (Independent of SYSCLK) ¹ (continued)At recommended operating conditions. See [Table 4](#).

Parameter	Symbol	Min	Max	Unit	Notes
Output hold times: Boundary-scan data TDO	t_{JLDX} t_{JLOX}	30 30	— —	ns	4
TCK to output high impedance: Boundary-scan data TDO	t_{JLDZ} t_{JLOZ}	3 3	19 9	ns	4, 5

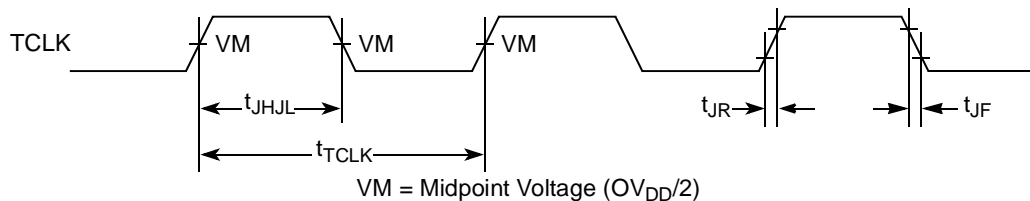
Notes:

- All outputs are measured from the midpoint voltage of the falling/rising edge of TCLK to the midpoint of the signal in question. The output timings are measured at the pins. All output timings assume a purely resistive 50- Ω load (see [Figure 13](#)). Time-of-flight delays must be added for trace lengths, vias, and connectors in the system.
- $\overline{\text{TRST}}$ is an asynchronous level sensitive signal. The setup time is for test purposes only.
- Non-JTAG signal input timing with respect to TCK.
- Non-JTAG signal output timing with respect to TCK.
- Guaranteed by design and characterization.

[Figure 13](#) provides the AC test load for TDO and the boundary-scan outputs of the MPC7457.

**Figure 13. Alternate AC Test Load for the JTAG Interface**

[Figure 14](#) provides the JTAG clock input timing diagram.

**Figure 14. JTAG Clock Input Timing Diagram**

[Figure 15](#) provides the $\overline{\text{TRST}}$ timing diagram.

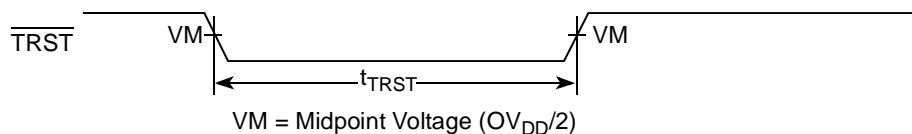
**Figure 15. $\overline{\text{TRST}}$ Timing Diagram**

Figure 16 provides the boundary-scan timing diagram.

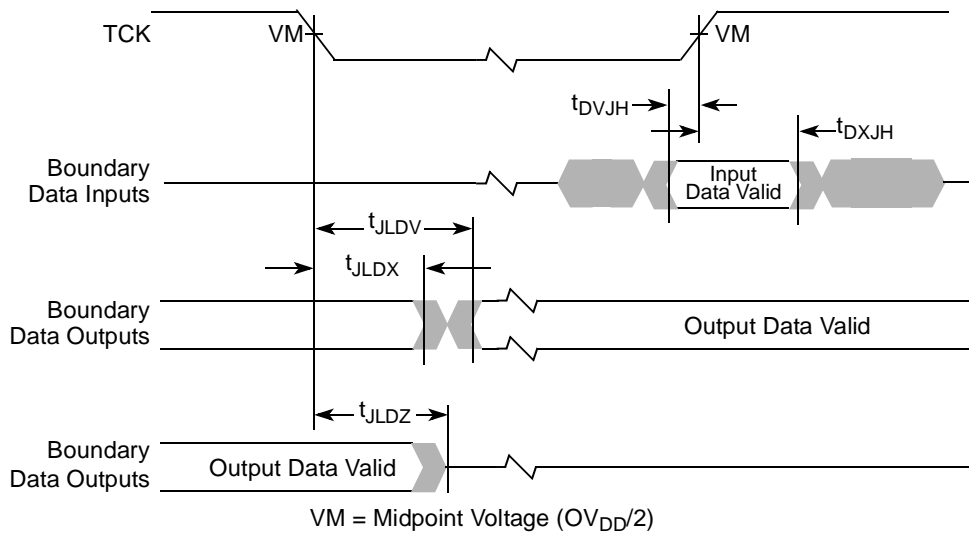


Figure 16. Boundary-Scan Timing Diagram

Figure 17 provides the test access port timing diagram.

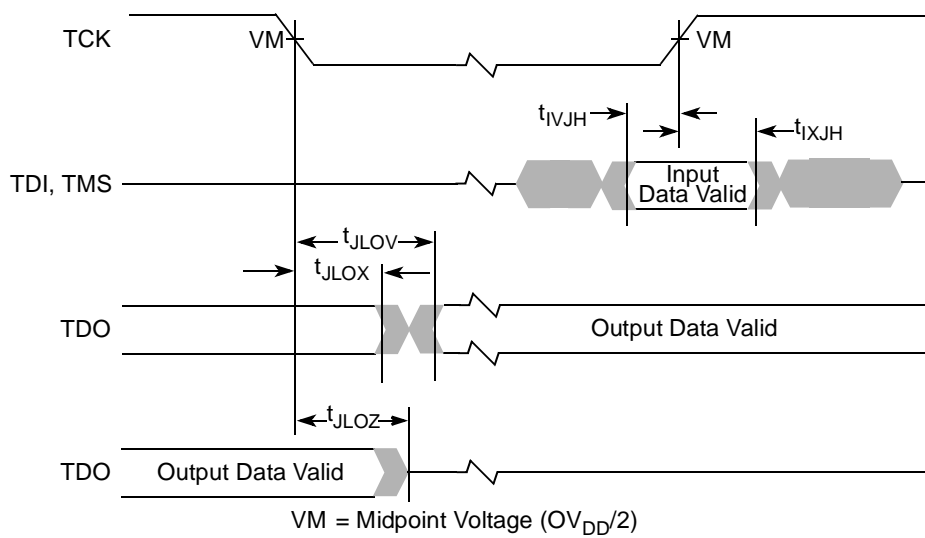
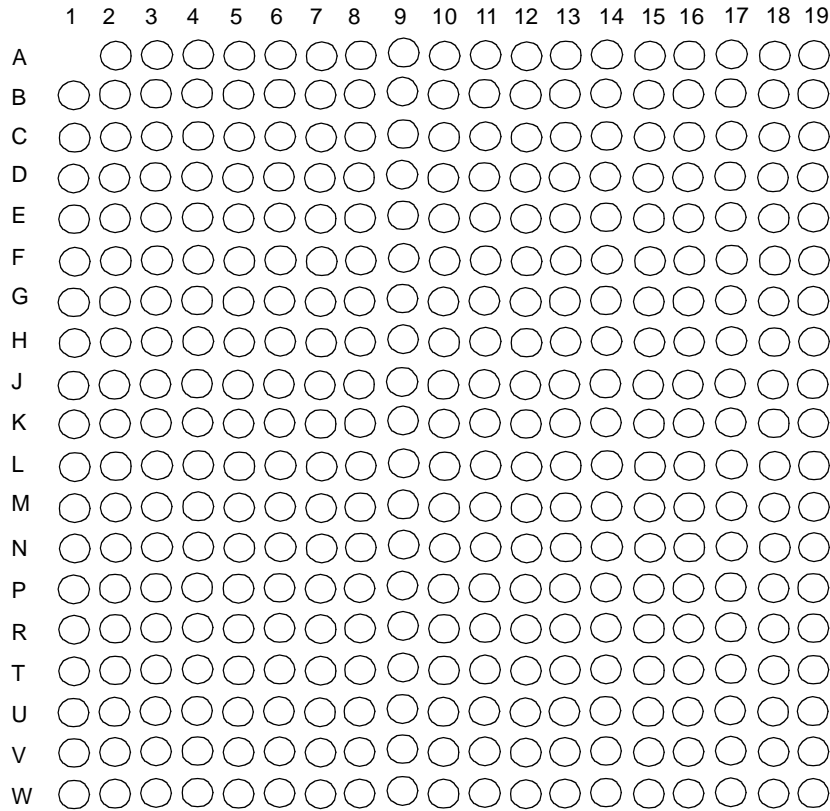


Figure 17. Test Access Port Timing Diagram

6 Pin Assignments

Figure 18 (Part A) shows the pinout of the MPC7447, 360 CBGA package as viewed from the top surface. Part B shows the side profile of the CBGA package to indicate the direction of the top surface view.

Part A



Not to Scale

Part B

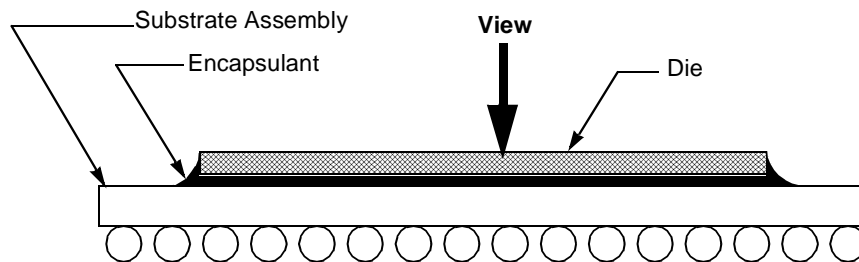
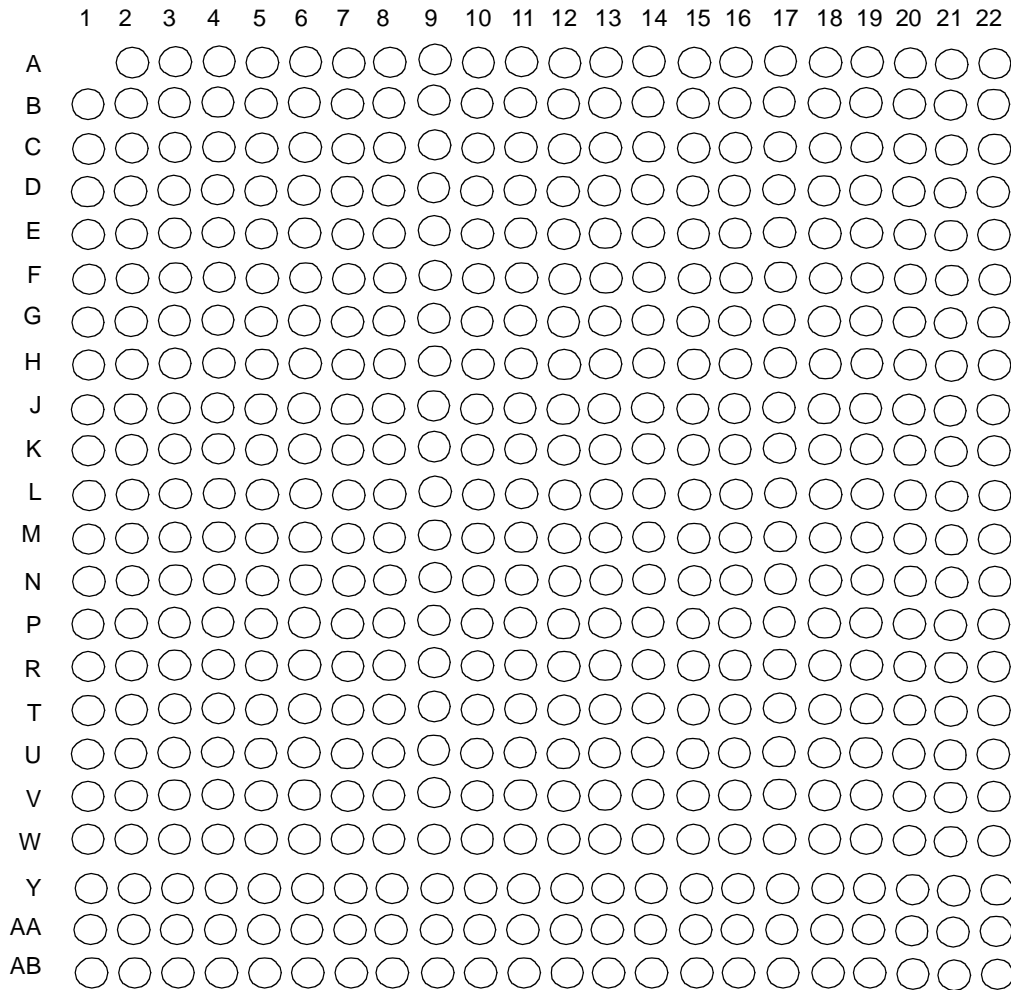


Figure 18. Pinout of the MPC7447, 360 CBGA Package as Viewed from the Top Surface

Pin Assignments

Figure 19 (Part A) shows the pinout of the MPC7457, 483 CBGA package as viewed from the top surface. Part B shows the side profile of the CBGA package to indicate the direction of the top surface view.

Part A



Not to Scale

Part B

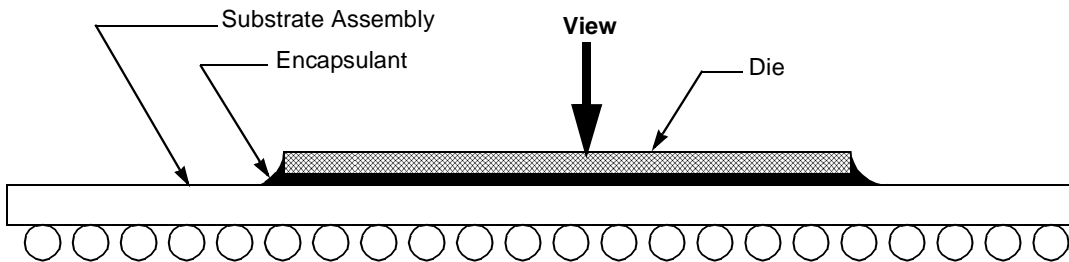


Figure 19. Pinout of the MPC7457, 483 CBGA Package as Viewed from the Top Surface

7 Pinout Listings

Table 16 provides the pinout listing for the MPC7447, 360 CBGA package. Table 17 provides the pinout listing for the MPC7457, 483 CBGA package.

NOTE

This pinout is not compatible with the MPC750, MPC7400, or MPC7410 360 BGA package.

Table 16. Pinout Listing for the MPC7447, 360 CBGA Package

Signal Name	Pin Number	Active	I/O	I/F Select ¹	Notes
A[0:35]	E11, H1, C11, G3, F10, L2, D11, D1, C10, G2, D12, L3, G4, T2, F4, V1, J4, R2, K5, W2, J2, K4, N4, J3, M5, P5, N3, T1, V2, U1, N5, W1, B12, C4, G10, B11	High	I/O	BVSEL	2
$\overline{\text{AACK}}$	R1	Low	Input	BVSEL	
AP[0:4]	C1, E3, H6, F5, G7	High	I/O	BVSEL	
$\overline{\text{ARTRY}}$	N2	Low	I/O	BVSEL	3
AV _{DD}	A8	—	Input	N/A	
$\overline{\text{BG}}$	M1	Low	Input	BVSEL	
$\overline{\text{BMODE0}}$	G9	Low	Input	BVSEL	4
$\overline{\text{BMODE1}}$	F8	Low	Input	BVSEL	5
$\overline{\text{BR}}$	D2	Low	Output	BVSEL	
BVSEL	B7	High	Input	BVSEL	1, 6
$\overline{\text{CI}}$	J1	Low	Output	BVSEL	3
$\overline{\text{CKSTP_IN}}$	A3	Low	Input	BVSEL	
$\overline{\text{CKSTP_OUT}}$	B1	Low	Output	BVSEL	
CLK_OUT	H2	High	Output	BVSEL	
D[0:63]	R15, W15, T14, V16, W16, T15, U15, P14, V13, W13, T13, P13, U14, W14, R12, T12, W12, V12, N11, N10, R11, U11, W11, T11, R10, N9, P10, U10, R9, W10, U9, V9, W5, U6, T5, U5, W7, R6, P7, V6, P17, R19, V18, R18, V19, T19, U19, W19, U18, W17, W18, T16, T18, T17, W3, V17, U4, U8, U7, R7, P6, R8, W8, T8	High	I/O	BVSEL	
$\overline{\text{DBG}}$	M2	Low	Input	BVSEL	
DP[0:7]	T3, W4, T4, W9, M6, V3, N8, W6	High	I/O	BVSEL	
$\overline{\text{DRDY}}$	R3	Low	Output	BVSEL	7
DTI[0:3]	G1, K1, P1, N1	High	Input	BVSEL	8
EXT_QUAL	A11	High	Input	BVSEL	9
$\overline{\text{GBL}}$	E2	Low	I/O	BVSEL	

Table 16. Pinout Listing for the MPC7447, 360 CBGA Package (continued)

Signal Name	Pin Number	Active	I/O	I/F Select ¹	Notes
GND	B5, C3, D6, D13, E17, F3, G17, H4, H7, H9, H11, H13, J6, J8, J10, J12, K7, K3, K9, K11, K13, L6, L8, L10, L12, M4, M7, M9, M11, M13, N7, P3, P9, P12, R5, R14, R17, T7, T10, U3, U13, U17, V5, V8, V11, V15	—	—	N/A	
$\overline{\text{HIT}}$	B2	Low	Output	BVSEL	7
$\overline{\text{HRESET}}$	D8	Low	Input	BVSEL	
$\overline{\text{INT}}$	D4	Low	Input	BVSEL	
L1_TSTCLK	G8	High	Input	BVSEL	9
L2_TSTCLK	B3	High	Input	BVSEL	10
No Connect	A6, A13, A14, A15, A16, A17, A18, A19, B13, B14, B15, B16, B17, B18, B19, C13, C14, C15, C16, C17, C18, C19, D14, D15, D16, D17, D18, D19, E12, E13, E14, E15, E16, E19, F12, F13, F14, F15, F16, F17, F18, F19, G11, G12, G13, G14, G15, G16, G19, H14, H15, H16, H17, H18, H19, J14, J15, J16, J17, J18, J19, K15, K16, K17, K18, K19, L14, L15, L16, L17, L18, L19, M14, M15, M16, M17, M18, M19, N12, N13, N14, N15, N16, N17, N18, N19, P15, P16, P18, P19	—	—	—	11
$\overline{\text{LSSD_MODE}}$	E8	Low	Input	BVSEL	6, 12
$\overline{\text{MCP}}$	C9	Low	Input	BVSEL	
OV _{DD}	B4, C2, C12, D5, E18, F2, G18, H3, J5, K2, L5, M3, N6, P2, P8, P11, R4, R13, R16, T6, T9, U2, U12, U16, V4, V7, V10, V14	—	—	N/A	
PLL_CFG[0:4]	B8, C8, C7, D7, A7	High	Input	BVSEL	
$\overline{\text{PMON_IN}}$	D9	Low	Input	BVSEL	13
$\overline{\text{PMON_OUT}}$	A9	Low	Output	BVSEL	
$\overline{\text{QACK}}$	G5	Low	Input	BVSEL	
$\overline{\text{QREQ}}$	P4	Low	Output	BVSEL	
$\overline{\text{SHD}}[0:1]$	E4, H5	Low	I/O	BVSEL	3
$\overline{\text{SMI}}$	F9	Low	Input	BVSEL	
$\overline{\text{SRESET}}$	A2	Low	Input	BVSEL	
SYSCLK	A10	—	Input	BVSEL	
$\overline{\text{TA}}$	K6	Low	Input	BVSEL	
TBEN	E1	High	Input	BVSEL	
$\overline{\text{TBST}}$	F11	Low	Output	BVSEL	
TCK	C6	High	Input	BVSEL	
TDI	B9	High	Input	BVSEL	6
TDO	A4	High	Output	BVSEL	

Table 16. Pinout Listing for the MPC7447, 360 CBGA Package (continued)

Signal Name	Pin Number	Active	I/O	I/F Select ¹	Notes
$\overline{\text{TEA}}$	L1	Low	Input	BVSEL	
TEST[0:3]	A12, B6, B10, E10	—	Input	BVSEL	12
TEST[4]	D10	—	Input	BVSEL	9
TMS	F1	High	Input	BVSEL	6
$\overline{\text{TRST}}$	A5	Low	Input	BVSEL	6, 14
$\overline{\text{TS}}$	L4	Low	I/O	BVSEL	3
TSIZ[0:2]	G6, F7, E7	High	Output	BVSEL	
TT[0:4]	E5, E6, F6, E9, C5	High	I/O	BVSEL	
$\overline{\text{WT}}$	D3	Low	Output	BVSEL	3
V _{DD}	H8, H10, H12, J7, J9, J11, J13, K8, K10, K12, K14, L7, L9, L11, L13, M8, M10, M12	—	—	N/A	

Notes:

1. OV_{DD} supplies power to the processor bus, JTAG, and all control signals; and V_{DD} supplies power to the processor core and the PLL (after filtering to become AV_{DD}). To program the I/O voltage, connect BVSEL to either GND (selects 1.8 V) or to $\overline{\text{HRESET}}$ (selects 2.5 V). If used, the pull-down resistor should be less than 250 Ω . For actual recommended value of V_{in} or supply voltages see Table 4.
2. Unused address pins must be pulled down to GND.
3. These pins require weak pull-up resistors (for example, 4.7 k Ω) to maintain the control signals in the negated state after they have been actively negated and released by the MPC7447 and other bus masters.
4. This signal selects between MPX bus mode (asserted) and 60x bus mode (negated) and will be sampled at $\overline{\text{HRESET}}$ going high.
5. This signal must be negated during reset, by pull up to OV_{DD} or negation by $\overline{\text{HRESET}}$ (inverse of $\overline{\text{HRESET}}$), to ensure proper operation.
6. Internal pull up on die.
7. Ignored in 60x bus mode.
8. These signals must be pulled down to GND if unused, or if the MPC7447 is in 60x bus mode.
9. These input signals are for factory use only and must be pulled down to GND for normal machine operation.
10. This test signal is recommended to be tied to $\overline{\text{HRESET}}$; however, other configurations will not adversely affect performance.
11. These signals are for factory use only and must be left unconnected for normal machine operation.
12. These input signals are for factory use only and must be pulled up to OV_{DD} for normal machine operation.
13. This pin can externally cause a performance monitor event. Counting of the event is enabled via software.
14. This signal must be asserted during reset, by pull down to GND or assertion by $\overline{\text{HRESET}}$, to ensure proper operation.

Table 17. Pinout Listing for the MPC7457, 483 CBGA Package

Signal Name	Pin Number	Active	I/O	I/F Select ¹	Notes
A[0:35]	E10, N4, E8, N5, C8, R2, A7, M2, A6, M1, A10, U2, N2, P8, M8, W4, N6, U6, R5, Y4, P1, P4, R6, M7, N7, AA3, U4, W2, W1, W3, V4, AA1, D10, J4, G10, D9	High	I/O	BVSEL	2
$\overline{\text{AACK}}$	U1	Low	Input	BVSEL	
AP[0:4]	L5, L6, J1, H2, G5	High	I/O	BVSEL	
$\overline{\text{ARTRY}}$	T2	Low	I/O	BVSEL	3

Table 17. Pinout Listing for the MPC7457, 483 CBGA Package (continued)

Signal Name	Pin Number	Active	I/O	I/F Select ¹	Notes
AV _{DD}	B2	—	Input	N/A	
$\overline{\text{BG}}$	R3	Low	Input	BVSEL	
$\overline{\text{BMODE0}}$	C6	Low	Input	BVSEL	4
$\overline{\text{BMODE1}}$	C4	Low	Input	BVSEL	5
$\overline{\text{BR}}$	K1	Low	Output	BVSEL	
BVSEL	G6	High	Input	N/A	6, 7
$\overline{\text{CI}}$	R1	Low	Output	BVSEL	3
$\overline{\text{CKSTP_IN}}$	F3	Low	Input	BVSEL	
$\overline{\text{CKSTP_OUT}}$	K6	Low	Output	BVSEL	
CLK_OUT	N1	High	Output	BVSEL	
D[0:63]	AB15, T14, R14, AB13, V14, U14, AB14, W16, AA11, Y11, U12, W13, Y14, U13, T12, W12, AB12, R12, AA13, AB11, Y12, V11, T11, R11, W10, T10, W11, V10, R10, U10, AA10, U9, V7, T8, AB4, Y6, AB7, AA6, Y8, AA7, W8, AB10, AA16, AB16, AB17, Y18, AB18, Y16, AA18, W14, R13, W15, AA14, V16, W6, AA12, V6, AB9, AB6, R7, R9, AA9, AB8, W9	High	I/O	BVSEL	
$\overline{\text{DBG}}$	V1	Low	Input	BVSEL	
DP[0:7]	AA2, AB3, AB2, AA8, R8, W5, U8, AB5	High	I/O	BVSEL	
$\overline{\text{DRDY}}$	T6	Low	Output	BVSEL	8
DTI[0:3]	P2, T5, U3, P6	High	Input	BVSEL	9
EXT_QUAL	B9	High	Input	BVSEL	10
$\overline{\text{GBL}}$	M4	Low	I/O	BVSEL	
GND	A22, B1, B5, B12, B14, B16, B18, B20, C3, C9, C21, D7, D13, D15, D17, D19, E2, E5, E21, F10, F12, F14, F16, F19, G4, G7, G17, G21, H13, H15, H19, H5, J3, J10, J12, J14, J17, J21, K5, K9, K11, K13, K15, K19, L10, L12, L14, L17, L21, M3, M6, M9, M11, M13, M19, N10, N12, N14, N17, N21, P3, P9, P11, P13, P15, P19, R17, R21, T13, T15, T19, T4, T7, T9, U17, U21, V2, V5, V8, V12, V15, V19, W7, W17, W21, Y3, Y9, Y13, Y15, Y20, AA5, AA17, AB1, AB22	—	—	N/A	
GV _{DD}	B13, B15, B17, B19, B21, D12, D14, D16, D18, D21, E19, F13, F15, F17, F21, G19, H12, H14, H17, H21, J19, K17, K21, L19, M17, M21, N19, P17, P21, R15, R19, T17, T21, U19, V17, V21, W19, Y21	—	—	N/A	11
$\overline{\text{HIT}}$	K2	Low	Output	BVSEL	8
$\overline{\text{HRESET}}$	A3	Low	Input	BVSEL	
$\overline{\text{INT}}$	J6	Low	Input	BVSEL	

Table 17. Pinout Listing for the MPC7457, 483 CBGA Package (continued)

Signal Name	Pin Number	Active	I/O	I/F Select ¹	Notes
L1_TSTCLK	H4	High	Input	BVSEL	10
L2_TSTCLK	J2	High	Input	BVSEL	12
L3VSEL	A4	High	Input	N/A	6, 7
L3ADDR[18:0]	H11, F20, J16, E22, H18, G20, F22, G22, H20, K16, J18, H22, J20, J22, K18, K20, L16, K22, L18	High	Output	L3VSEL	
L3_CLK[0:1]	V22, C17	High	Output	L3VSEL	
$\overline{\text{L3_CNTL}}[0:1]$	L20, L22	Low	Output	L3VSEL	
L3DATA[0:63]	AA19, AB20, U16, W18, AA20, AB21, AA21, T16, W20, U18, Y22, R16, V20, W22, T18, U20, N18, N20, N16, N22, M16, M18, M20, M22, R18, T20, U22, T22, R20, P18, R22, M15, G18, D22, E20, H16, C22, F18, D20, B22, G16, A21, G15, E17, A20, C19, C18, A19, A18, G14, E15, C16, A17, A16, C15, G13, C14, A14, E13, C13, G12, A13, E12, C12	High	I/O	L3VSEL	
L3DP[0:7]	AB19, AA22, P22, P16, C20, E16, A15, A12	High	I/O	L3VSEL	
L3_ECHO_CLK[0,2]	V18, E18	High	Input	L3VSEL	
L3_ECHO_CLK[1,3]	P20, E14	High	I/O	L3VSEL	
$\overline{\text{LSSD_MODE}}$	F6	Low	Input	BVSEL	7, 13
$\overline{\text{MCP}}$	B8	Low	Input	BVSEL	
No Connect	A8, A11, B6, B11, C11, D11, D3, D5, E11, E7, F2, F11, G2, H9	—	—	N/A	14
OV _{DD}	B3, C5, C7, C10, D2, E3, E9, F5, G3, G9, H7, J5, K3, L7, M5, N3, P7, R4, T3, U5, U7, U11, U15, V3, V9, V13, Y2, Y5, Y7, Y10, Y17, Y19, AA4, AA15	—	—	N/A	
PLL_CFG[0:4]	A2, F7, C2, D4, H8	High	Input	BVSEL	
$\overline{\text{PMON_IN}}$	E6	Low	Input	BVSEL	15
$\overline{\text{PMON_OUT}}$	B4	Low	Output	BVSEL	
$\overline{\text{QACK}}$	K7	Low	Input	BVSEL	
$\overline{\text{QREQ}}$	Y1	Low	Output	BVSEL	
$\overline{\text{SHD}}[0:1]$	L4, L8	Low	I/O	BVSEL	3
$\overline{\text{SMI}}$	G8	Low	Input	BVSEL	
$\overline{\text{SRESET}}$	G1	Low	Input	BVSEL	
SYSCLK	D6	—	Input	BVSEL	
$\overline{\text{TA}}$	N8	Low	Input	BVSEL	
TBEN	L3	High	Input	BVSEL	
$\overline{\text{TBST}}$	B7	Low	Output	BVSEL	
TCK	J7	High	Input	BVSEL	

Table 17. Pinout Listing for the MPC7457, 483 CBGA Package (continued)

Signal Name	Pin Number	Active	I/O	I/F Select ¹	Notes
TDI	E4	High	Input	BVSEL	7
TDO	H1	High	Output	BVSEL	
$\overline{\text{TEA}}$	T1	Low	Input	BVSEL	
TEST[0:5]	B10, H6, H10, D8, F9, F8	—	Input	BVSEL	13
TEST[6]	A9	—	Input	BVSEL	10
TMS	K4	High	Input	BVSEL	7
$\overline{\text{TRST}}$	C1	Low	Input	BVSEL	7, 16
$\overline{\text{TS}}$	P5	Low	I/O	BVSEL	3
TSIZ[0:2]	L1, H3, D1	High	Output	BVSEL	
TT[0:4]	F1, F4, K8, A5, E1	High	I/O	BVSEL	
$\overline{\text{WT}}$	L2	Low	Output	BVSEL	3
V _{DD}	J9, J11, J13, J15, K10, K12, K14, L9, L11, L13, L15, M10, M12, M14, N9, N11, N13, N15, P10, P12, P14	—	—	N/A	
VDD_SENSE[0:1]	G11, J8	—	—	N/A	17

Notes:

1. OV_{DD} supplies power to the processor bus, JTAG, and all control signals except the L3 cache controls (L3CTL[0:1]); GV_{DD} supplies power to the L3 cache interface (L3ADDR[0:17], L3DATA[0:63], L3DP[0:7], L3_ECHO_CLK[0:3], and L3_CLK[0:1]) and the L3 control signals L3_CNTL[0:1]; and V_{DD} supplies power to the processor core and the PLL (after filtering to become AV_{DD}). For actual recommended value of V_{in} or supply voltages, see Table 4.
2. Unused address pins must be pulled down to GND.
3. These pins require weak pull-up resistors (for example, 4.7 k Ω) to maintain the control signals in the negated state after they have been actively negated and released by the MPC7457 and other bus masters.
4. This signal selects between MPX bus mode (asserted) and 60x bus mode (negated) and will be sampled at $\overline{\text{HRESET}}$ going high.
5. This signal must be negated during reset, by pull up to OV_{DD} or negation by $\overline{\text{HRESET}}$ (inverse of HRESET), to ensure proper operation.
6. See Table 3 for bus voltage configuration information. If used, pull-down resistors should be less than 250 Ω .
7. Internal pull up on die.
8. Ignored in 60x bus mode.
9. These signals must be pulled down to GND if unused or if the MPC7457 is in 60x bus mode.
10. These input signals for factory use only and must be pulled down to GND for normal machine operation.
11. Power must be supplied to GV_{DD}, even when the L3 interface is disabled or unused.
12. This test signal is recommended to be tied to $\overline{\text{HRESET}}$; however, other configurations will not adversely affect performance.
13. These input signals are for factory use only and must be pulled up to OV_{DD} for normal machine operation.
14. These signals are for factory use only and must be left unconnected for normal machine operation.
15. This pin can externally cause a performance monitor event. Counting of the event is enabled via software.
16. This signal must be asserted during reset, by pull down to GND or assertion by HRESET, to ensure proper operation.
17. These pins are internally connected to V_{DD}. They are intended to allow an external device to detect the core voltage level present at the processor core. If unused, they must be connected directly to V_{DD} or left unconnected.

8 Package Description

The following sections provide the package parameters and mechanical dimensions for the CBGA package.

8.1 Package Parameters for the MPC7447, 360 CBGA

The package parameters are as provided in the following list. The package type is 25 × 25 mm, 360-lead ceramic ball grid array (CBGA).

Package outline	25 × 25 mm
Interconnects	360 (19 × 19 ball array – 1)
Pitch	1.27 mm (50 mil)
Minimum module height	2.72 mm
Maximum module height	3.24 mm
Ball diameter	0.89 mm (35 mil)

8.2 Mechanical Dimensions for the MPC7447, 360 CBGA

[Figure 20](#) provides the mechanical dimensions and bottom surface nomenclature for the MPC7447, 360 CBGA package.

Package Description

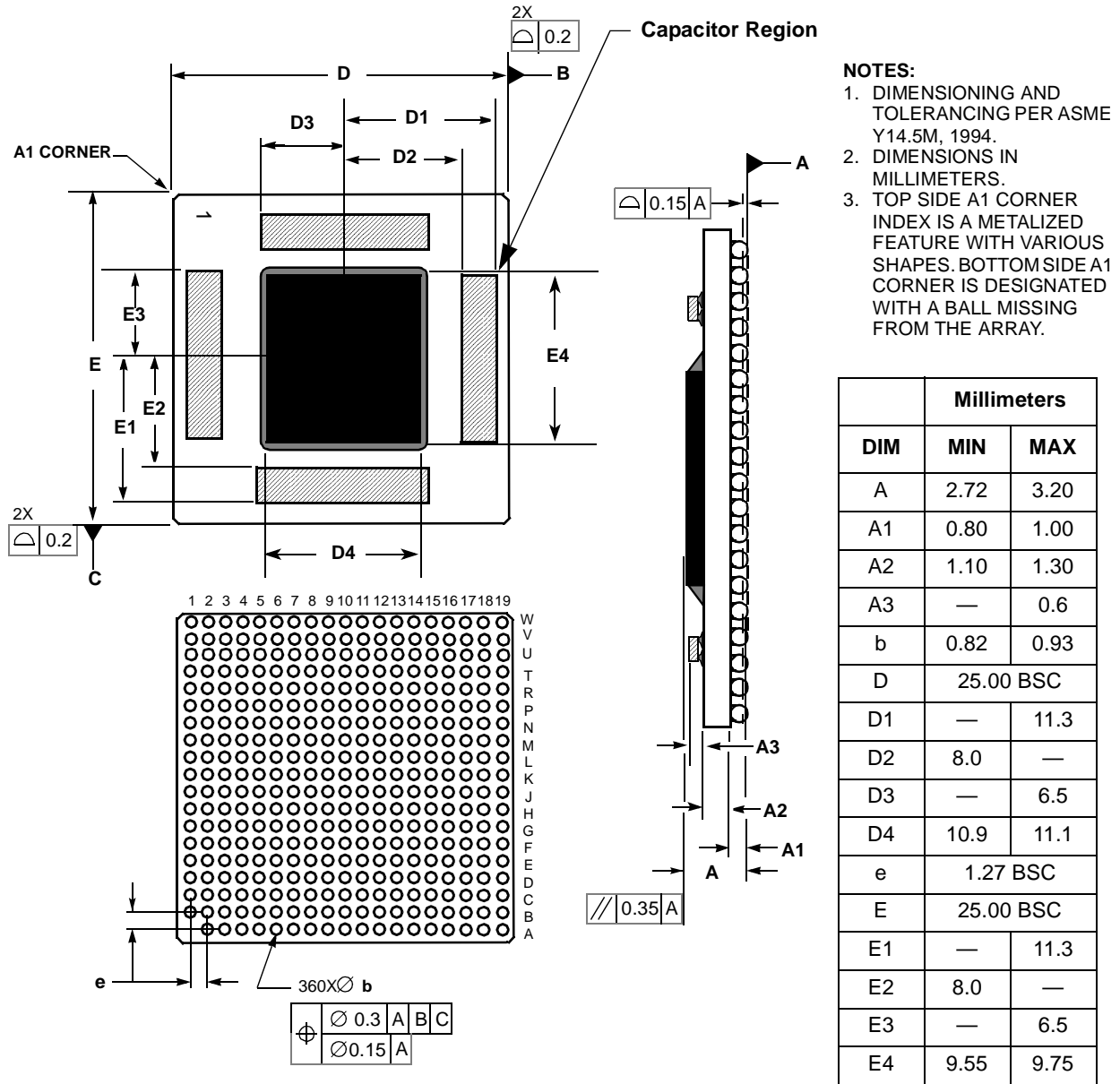


Figure 20. Mechanical Dimensions and Bottom Surface Nomenclature for the MPC7447, 360 CBGA Package

8.3 Substrate Capacitors for the MPC7447, 360 CBGA

Figure 21 shows the connectivity of the substrate capacitor pads for the MPC7447, 360 CBGA. All capacitors are 100 nF.

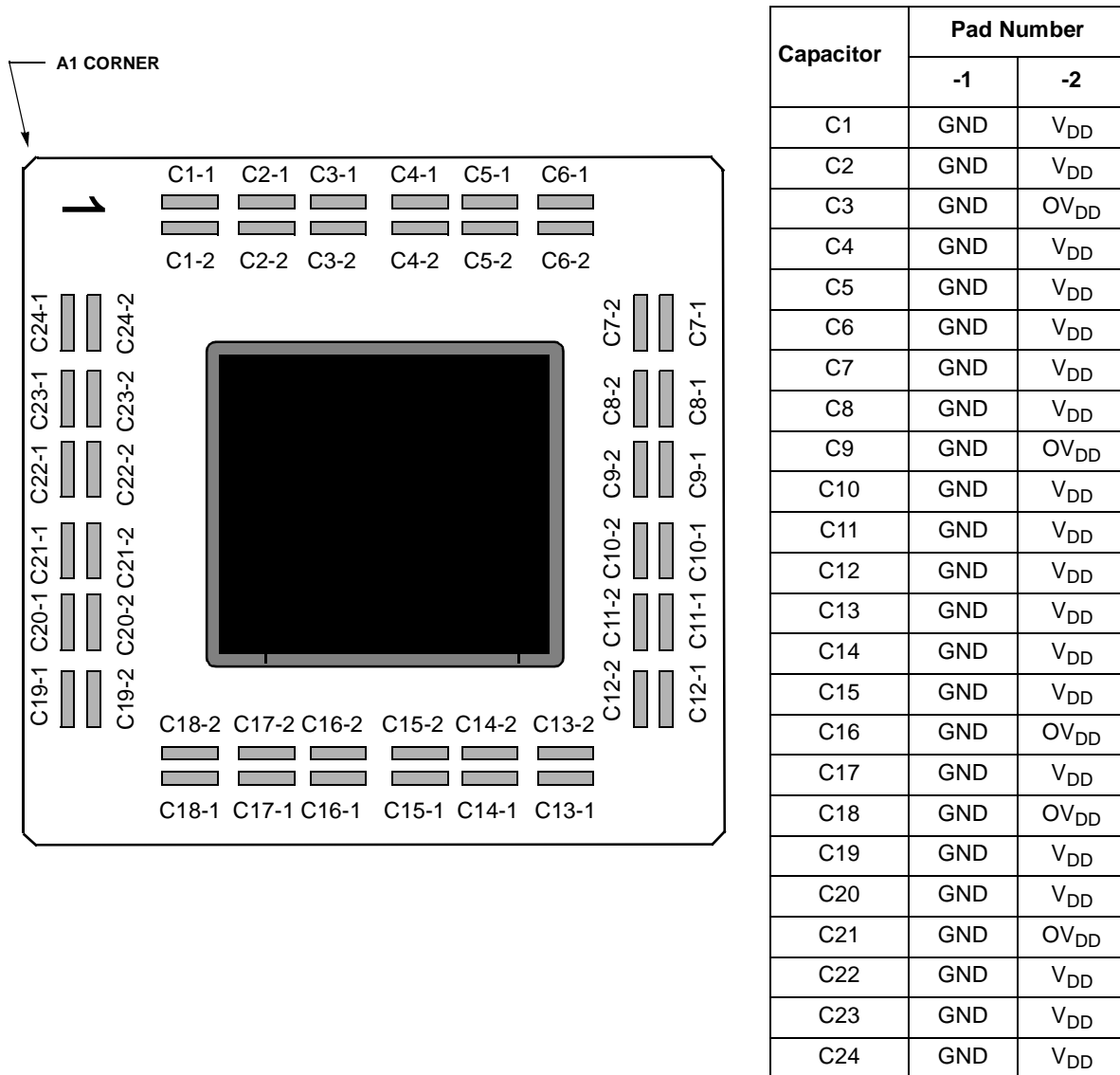


Figure 21. Substrate Bypass Capacitors for the MPC7447, 360 CBGA

8.4 Package Parameters for the MPC7457, 483 CBGA

The package parameters are as provided in the following list. The package type is 29 × 29 mm, 483-lead ceramic ball grid array (CBGA).

Package outline	29 × 29 mm
Interconnects	483 (22 × 22 ball array – 1)
Pitch	1.27 mm (50 mil)
Minimum module height	—
Maximum module height	3.22 mm
Ball diameter	0.89 mm (35 mil)

8.5 Mechanical Dimensions for the MPC7457, 483 CBGA

[Figure 22](#) provides the mechanical dimensions and bottom surface nomenclature for the MPC7457, 483 CBGA package.

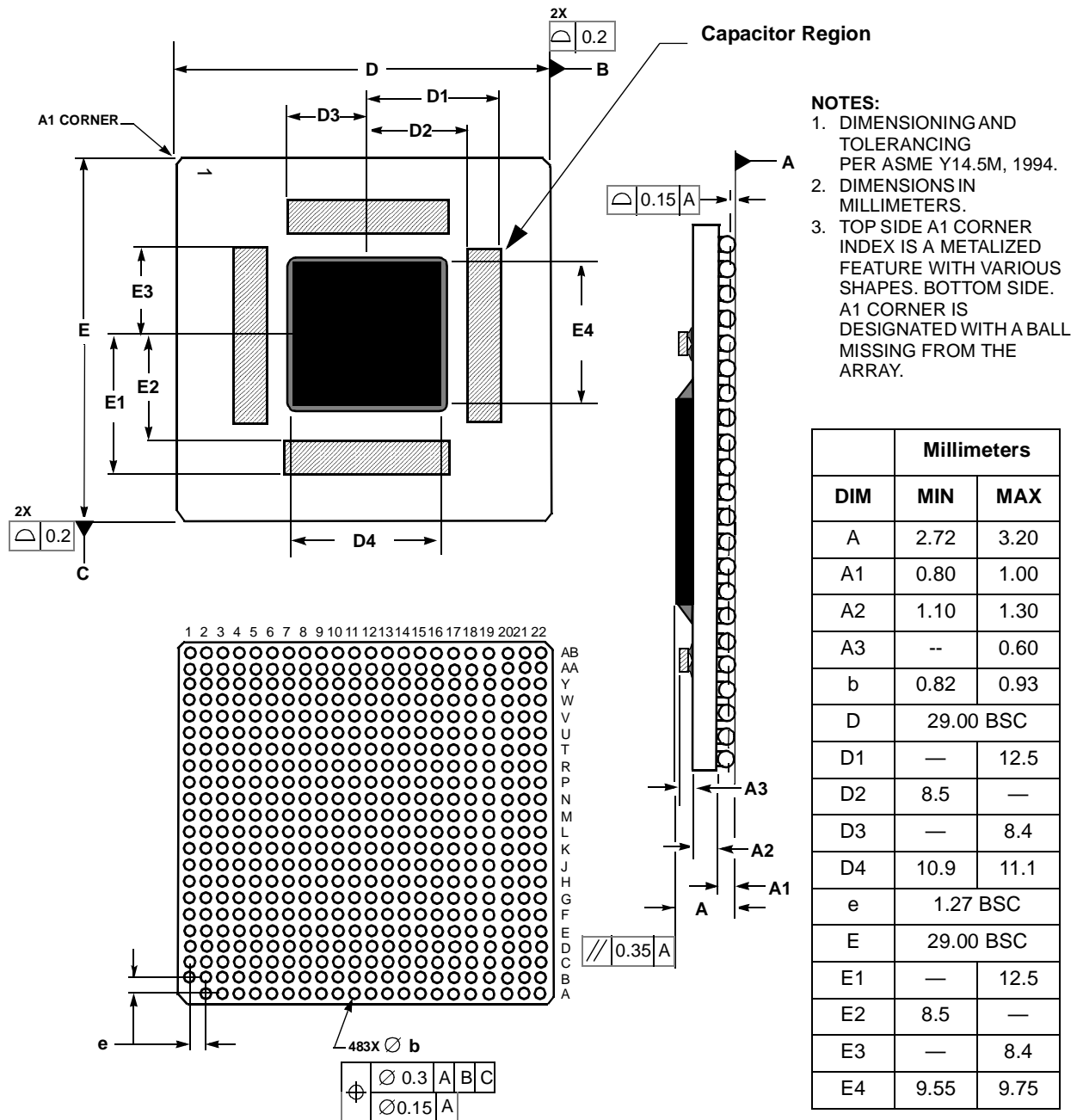


Figure 22. Mechanical Dimensions and Bottom Surface Nomenclature for the MPC7457, 483 CBGA Package

8.6 Substrate Capacitors for the MPC7457, 483 CBGA

Figure 23 shows the connectivity of the substrate capacitor pads for the MPC7457, 483 CBGA. All capacitors are 100 nF.

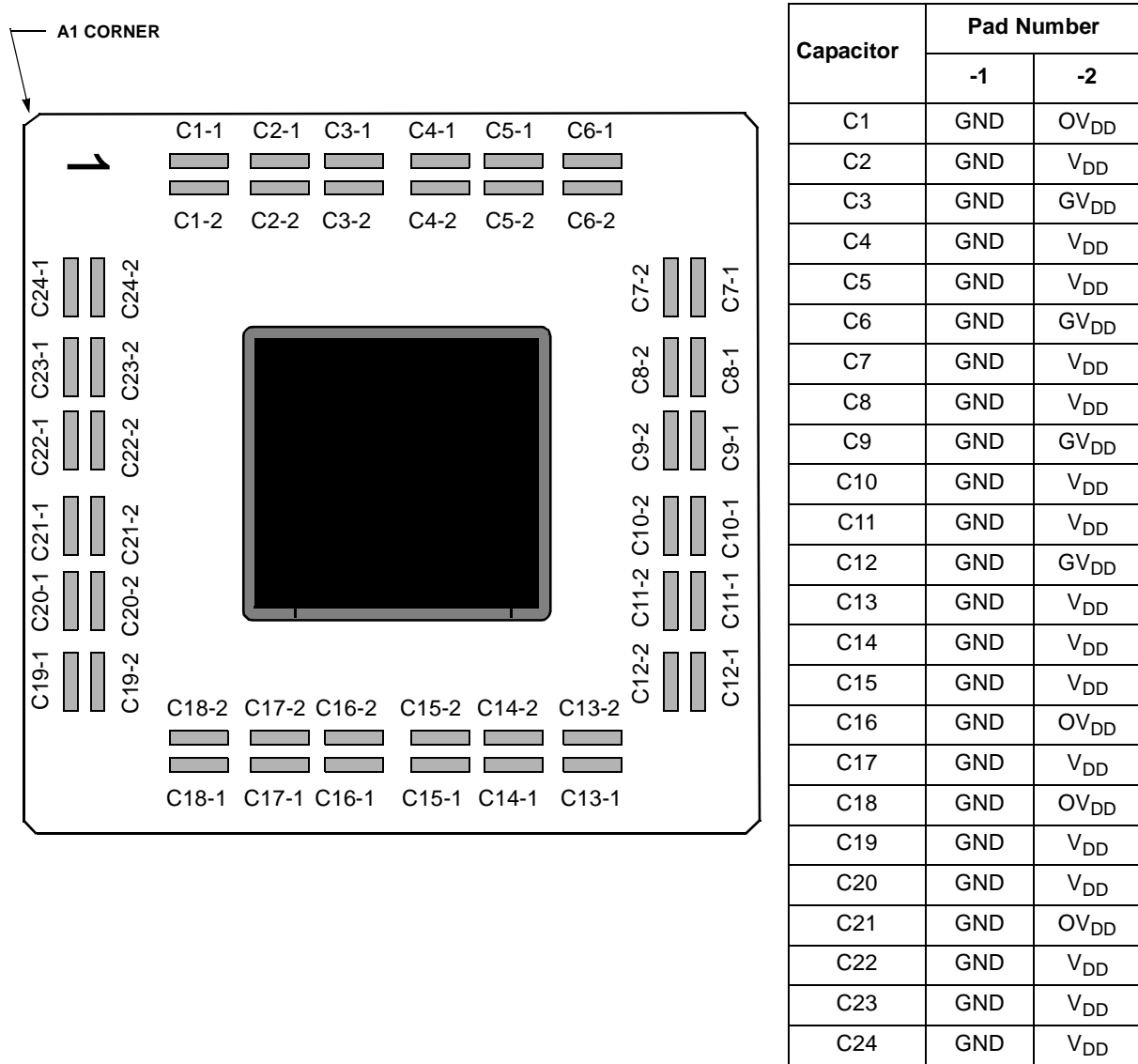


Figure 23. Substrate Bypass Capacitors for the MPC7457, 483 CBGA

9 System Design Information

This section provides system and thermal design recommendations for successful application of the MPC7457.

9.1 Clocks

The following sections provide more detailed information regarding the clocking of the MPC7457.

9.1.1 Core Clocks and PLL Configuration

The MPC7457 PLL is configured by the PLL_CFG[0:4] signals. For a given SYSCLK (bus) frequency, the PLL configuration signals set the internal CPU and VCO frequency of operation. The PLL configuration for the MPC7457 is shown in Table 18 for a set of example frequencies. In this example, shaded cells represent settings that, for a given SYSCLK frequency, result in core and/or VCO frequencies that do not comply with the 1-GHz column in Table 8. Note that these configurations were different in some earlier MPC7450-family devices and care should be taken when upgrading to the MPC7457 to verify the correct PLL settings for an application.

Table 18. MPC7457 Microprocessor PLL Configuration Example for 1267 MHz Parts

PLL_CFG[0:4]	Bus-to-Core Multiplier	Core-to-VCO Multiplier	Example Bus-to-Core Frequency in MHz (VCO Frequency in MHz)								
			Bus (SYSCLK) Frequency								
			33.3 MHz	50 MHz	66.6 MHz	75 MHz	83 MHz	100 MHz	133 MHz	167 MHz	
01000	2x	2x									
10000	3x	2x									
10100	4x	2x									667 (1333)
10110	5x	2x								667 (1333)	835 (1670)
10010	5.5x	2x								733 (1466)	919 (1837)
11010	6x	2x						600 (1200)	800 (1600)	1002 (2004)	
01010	6.5x	2x						650 (1300)	866 (1730)	1086 (2171)	
00100	7x	2x						700 (1400)	931 (1862)	1169 (2338)	
00010	7.5x	2x					623 (1245)	750 (1500)	1000 (2000)	1253 (2505)	
11000	8x	2x				600 (1200)	664 (1328)	800 (1600)	1064 (2128)		
01100	8.5x	2x				638 (1276)	706 (1412)	850 (1700)	1131 (2261)		
01111	9x	2x			600 (1200)	675 (1350)	747 (1494)	900 (1800)	1197 (2394)		

Table 18. MPC7457 Microprocessor PLL Configuration Example for 1267 MHz Parts (continued)

PLL_CFG[0:4]	Bus-to-Core Multiplier	Core-to-VCO Multiplier	Example Bus-to-Core Frequency in MHz (VCO Frequency in MHz)							
			Bus (SYSCLK) Frequency							
			33.3 MHz	50 MHz	66.6 MHz	75 MHz	83 MHz	100 MHz	133 MHz	167 MHz
01110	9.5x	2x			633 (1266)	712 (1524)	789 (1578)	950 (1900)	1264 (2528)	
10101	10x	2x			667 (1333)	750 (1500)	830 (1660)	1000 (2000)		
10001	10.5x	2x			700 (1400)	938 (1876)	872 (1744)	1050 (2100)		
10011	11x	2x			733 (1466)	825 (1650)	913 (1826)	1100 (2200)		
00000	11.5x	2x			766 (532)	863 (1726)	955 (1910)	1150 (2300)		
10111	12x	2x		600 (1200)	800 (1600)	900 (1800)	996 (1992)	1200 (2400)		
11111	12.5x	2x		600 (1200)	833 (1666)	938 (1876)	1038 (2076)	1250 (2500)		
01011	13x	2x		650 (1300)	865 (1730)	975 (1950)	1079 (2158)			
11100	13.5x	2x		675 (1350)	900 (1800)	1013 (2026)	1121 (2242)			
11001	14x	2x		700 (1400)	933 (1866)	1050 (2100)	1162 (2324)			
00011	15x	2x		750 (1500)	1000 (2000)	1125 (2250)	1245 (2490)			
11011	16x	2x		800 (1600)	1066 (2132)	1200 (2400)				
00001	17x	2x		850 (1900)	1132 (2264)					
00101	18x	2x	600 (1200)	900 (1800)	1200 (2400)					
00111	20x	2x	667 (1334)	1000 (2000)						
01001	21x	2x	700 (1400)	1050 (2100)						
01101	24x	2x	800 (1600)	1200 (2400)						
11101	28x	2x	933 (1866)							
00110	PLL bypass		PLL off, SYSCLK clocks core circuitry directly							

Table 18. MPC7457 Microprocessor PLL Configuration Example for 1267 MHz Parts (continued)

PLL_CFG[0:4]	Bus-to-Core Multiplier	Core-to-VCO Multiplier	Example Bus-to-Core Frequency in MHz (VCO Frequency in MHz)							
			Bus (SYSCLK) Frequency							
			33.3 MHz	50 MHz	66.6 MHz	75 MHz	83 MHz	100 MHz	133 MHz	167 MHz
11110	PLL off		PLL off, no core clocking occurs							

Notes:

1. PLL_CFG[0:4] settings not listed are reserved.
2. The sample bus-to-core frequencies shown are for reference only. Some PLL configurations may select bus, core, or VCO frequencies which are not useful, not supported, or not tested for by the MPC7455; see [Section 5.2.1, "Clock AC Specifications,"](#) for valid SYSCLK, core, and VCO frequencies.
3. In PLL-bypass mode, the SYSCLK input signal clocks the internal processor directly and the PLL is disabled. However, the bus interface unit requires a 2x clock to function. Therefore, an additional signal, EXT_QUAL, must be driven at one-half the frequency of SYSCLK and offset in phase to meet the required input setup t_{IVKH} and hold time t_{IXKH} (see [Table 9](#)). The result is that the processor bus frequency is one-half SYSCLK while the internal processor is clocked at SYSCLK frequency. This mode is intended for factory use and emulator tool use only.
Note: The AC timing specifications given in this document do not apply in PLL-bypass mode.
4. In PLL-off mode, no clocking occurs inside the MPC7455 regardless of the SYSCLK input.

9.1.2 L3 Clocks

The MPC7457 generates the clock for the external L3 synchronous data SRAMs by dividing the core clock frequency of the MPC7457. The core-to-L3 frequency divisor for the L3 PLL is selected through the L3_CLK bits of the L3CR register. Generally, the divisor must be chosen according to the frequency supported by the external RAMs, the frequency of the MPC7457 core, and timing analysis of the circuit board routing. [Table 19](#) shows various example L3 clock frequencies that can be obtained for a given set of core frequencies.

Table 19. Sample Core-to-L3 Frequencies ¹

Core Frequency (MHz) ²	÷2	÷2.5	÷3	÷3.5	÷4	÷4.5	÷5	÷5.5	÷6	÷6.5	÷7	÷7.5	÷8
500	250	200	167	143	125	111	100	91	83	77	71	67	63
533	266	213	178	152	133	118	107	97	89	82	76	71	67
550	275	220	183	157	138	122	110	100	92	85	79	73	69
600	300	240	200	171	150	133	120	109	100	92	86	80	75
650	325	260	217	186	163	144	130	118	108	100	93	87	81
666	333	266	222	190	167	148	133	121	111	102	95	89	83
700	350	280	233	200	175	156	140	127	117	108	100	93	88
733	367	293	244	209	183	163	147	133	122	113	105	98	92
800	400	320	266	230	200	178	160	145	133	123	114	107	100
866	433	347	289	248	217	192	173	157	145	133	124	115	108
933	467	373	311	266	233	207	187	170	156	144	133	124	117
1000	500	400	333	285	250	222	200	182	166	154	143	133	125
1050	525	420	350	300	263	233	191	191	175	162	150	140	131
1100	550	440	367	314	275	244	200	200	183	169	157	147	138

Table 19. Sample Core-to-L3 Frequencies ¹ (continued)

Core Frequency (MHz) ²	÷2	÷2.5	÷3	÷3.5	÷4	÷4.5	÷5	÷5.5	÷6	÷6.5	÷7	÷7.5	÷8
1150	575	460	383	329	288	256	209	209	192	177	164	153	144
1200	600	480	400	343	300	267	218	218	200	185	171	160	150
1250	638	500	417	357	313	278	227	227	208	192	179	167	156
1300	650	520	433	371	325	289	236	236	217	200	186	173	163

Notes:

1. The core and L3 frequencies are for reference only. Note that maximum L3 frequency is design dependent. Some examples may represent core or L3 frequencies which are not useful, not supported, or not tested for the MPC7457; see [Section 5.2.3, "L3 Clock AC Specifications,"](#) for valid L3_CLK frequencies and for more information regarding the maximum L3 frequency.
2. Not all core frequencies are supported by all speed grades; see [Table 8](#) for minimum and maximum core frequency specifications.

9.1.3 System Bus Clock (SYSCLK) and Spread Spectrum Sources

Spread spectrum clock sources are an increasingly popular way to control electromagnetic interference emissions (EMI) by spreading the emitted noise to a wider spectrum and reducing the peak noise magnitude in order to meet industry and government requirements. These clock sources intentionally add long-term jitter in order to diffuse the EMI spectral content. The jitter specification given in [Table 8](#) considers short-term (cycle-to-cycle) jitter only and the clock generator's cycle-to-cycle output jitter should meet the MPC7457 input cycle-to-cycle jitter requirement. Frequency modulation and spread are separate concerns, and the MPC7457 is compatible with spread spectrum sources if the recommendations listed in [Table 20](#) are observed.

Table 20. Spread Spectrum Clock Source Recommendations

At recommended operating conditions. See [Table 4](#).

Parameter	Min	Max	Unit	Notes
Frequency modulation	—	50	kHz	1
Frequency spread	—	1.0	%	1, 2

Notes:

1. Guaranteed by design.
2. SYSCLK frequencies resulting from frequency spreading, and the resulting core and VCO frequencies, must meet the minimum and maximum specifications given in [Table 8](#).

It is imperative to note that the processor's minimum and maximum SYSCLK, core, and VCO frequencies must not be exceeded regardless of the type of clock source. Therefore, systems in which the processor is operated at its maximum rated core or bus frequency should avoid violating the stated limits by using down-spreading only.

9.2 PLL Power Supply Filtering

The AV_{DD} power signal is provided on the MPC7457 to provide power to the clock generation PLL. To ensure stability of the internal clock, the power supplied to the AV_{DD} input signal should be filtered of any noise in the 500 kHz to 10 MHz resonant frequency range of the PLL. A circuit similar to the one shown in [Figure 24](#) using surface mount capacitors with minimum effective series inductance (ESL) is recommended.

The circuit should be placed as close as possible to the AV_{DD} pin to minimize noise coupled from nearby circuits. It is often possible to route directly from the capacitors to the AV_{DD} pin, which is on the periphery of the 360 CBGA footprint and very close to the periphery of the 483 CBGA footprint, without the inductance of vias.

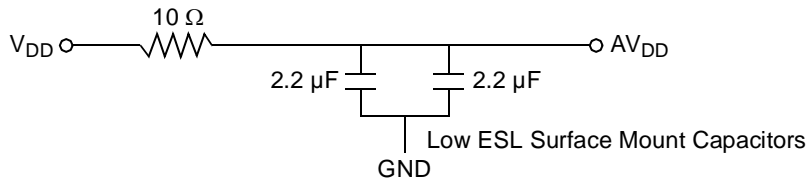


Figure 24. PLL Power Supply Filter Circuit

NOTE

Previous revisions of this document required a 400 Ω resistor for Rev. 1.1 (Rev. B) devices instead of the 10 Ω resistor shown above. All production devices require a 10 Ω resistor. For more information, see the *MPC7450 Family Chip Errata for the MPC7457 and MPC7447*.

9.3 Decoupling Recommendations

Due to the MPC7457 dynamic power management feature, large address and data buses, and high operating frequencies, the MPC7457 can generate transient power surges and high frequency noise in its power supply, especially while driving large capacitive loads. This noise must be prevented from reaching other components in the MPC7457 system, and the MPC7457 itself requires a clean, tightly regulated source of power. Therefore, it is recommended that the system designer place at least one decoupling capacitor at each V_{DD} , OV_{DD} , and GV_{DD} pin of the MPC7457. It is also recommended that these decoupling capacitors receive their power from separate V_{DD} , OV_{DD}/GV_{DD} , and GND power planes in the PCB, utilizing short traces to minimize inductance. If compromises must be made due to board constraints, V_{DD} pins should receive the highest priority for decoupling.

These capacitors should have a value of 0.01 or 0.1 μF . Only ceramic surface mount technology (SMT) capacitors should be used to minimize lead inductance, preferably 0508 or 0603 orientations where connections are made along the length of the part. Consistent with the recommendations of Dr. Howard Johnson in *High Speed Digital Design: A Handbook of Black Magic* (Prentice Hall, 1993) and contrary to previous recommendations for decoupling Freescale microprocessors, multiple small capacitors of equal value are recommended over using multiple values of capacitance.

In addition, it is recommended that there be several bulk storage capacitors distributed around the PCB, feeding the V_{DD} , GV_{DD} , and OV_{DD} planes, to enable quick recharging of the smaller chip capacitors. These bulk capacitors should have a low equivalent series resistance (ESR) rating to ensure the quick response time necessary. They should also be connected to the power and ground planes through two vias to minimize inductance. Suggested bulk capacitors: 100–330 μF (AVX TPS tantalum or Sanyo OSCON).

9.4 Connection Recommendations

To ensure reliable operation, it is highly recommended to connect unused inputs to an appropriate signal level. Unused active low inputs should be tied to OV_{DD} . Unused active high inputs should be connected to GND. All NC (no-connect) signals must remain unconnected.

Power and ground connections must be made to all external V_{DD} , OV_{DD} , GV_{DD} , and GND pins in the MPC7457. If the L3 interface is not used, GV_{DD} should be connected to the OV_{DD} power plane, and L3VSEL should be connected to BVSEL; the remainder of the L3 interface may be left unterminated.

9.5 Output Buffer DC Impedance

The MPC7457 processor bus and L3 I/O drivers are characterized over process, voltage, and temperature. To measure Z_0 , an external resistor is connected from the chip pad to OV_{DD} or GND. Then, the value of each resistor is varied until the pad voltage is $OV_{DD}/2$ (see Figure 23).

The output impedance is the average of two components, the resistances of the pull-up and pull-down devices. When data is held low, SW2 is closed (SW1 is open), and R_N is trimmed until the voltage at the pad equals $OV_{DD}/2$. R_N then becomes the resistance of the pull-down devices. When data is held high, SW1 is closed (SW2 is open), and R_P is trimmed until the voltage at the pad equals $OV_{DD}/2$. R_P then becomes the resistance of the pull-up devices. R_P and R_N are designed to be close to each other in value. Then, $Z_0 = (R_P + R_N)/2$.

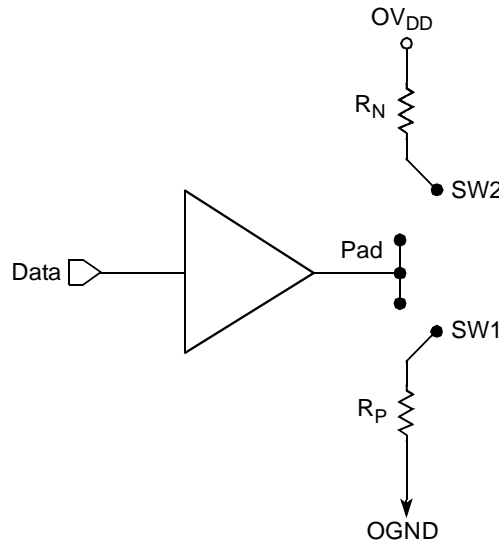


Figure 25. Driver Impedance Measurement

Table 21 summarizes the signal impedance results. The impedance increases with junction temperature and is relatively unaffected by bus voltage.

Table 21. Impedance Characteristics

$V_{DD} = 1.5\text{ V}$, $OV_{DD} = 1.8\text{ V} \pm 5\%$, $T_j = 5^\circ\text{--}85^\circ\text{C}$

Impedance		Processor Bus	L3 Bus	Unit
Z_0	Typical	33–42	34–42	Ω
	Maximum	31–51	32–44	Ω

9.6 Pull-Up/Pull-Down Resistor Requirements

The MPC7457 requires high-resistive (weak: 4.7-k Ω) pull-up resistors on several control pins of the bus interface to maintain the control signals in the negated state after they have been actively negated and released by the MPC7457 or other bus masters. These pins are: \overline{TS} , \overline{ARTRY} , \overline{SHDO} , and \overline{SHDI} .

Some pins designated as being for factory test must be pulled up to OV_{DD} or down to GND to ensure proper device operation. For the MPC7447, 360 BGA, the pins that must be pulled up to OV_{DD} are: $\overline{LSSD_MODE}$ and TEST[0:3]; the pins that must be pulled down to GND are: L1_TSTCLK and TEST[4]. For the MPC7457, 483 BGA, the pins that must be pulled up to OV_{DD} are: $\overline{LSSD_MODE}$ and TEST[0:5]; the pins that must be pulled down are:

L1_TSTCLK and TEST[6]. The $\overline{\text{CKSTP_IN}}$ signal should likewise be pulled up through a pull-up resistor (weak or stronger: 4.7–1 k Ω) to prevent erroneous assertions of this signal.

In addition, the MPC7457 has one open-drain style output that requires a pull-up resistor (weak or stronger: 4.7–1 k Ω) if it is used by the system. This pin is $\overline{\text{CKSTP_OUT}}$.

If pull-down resistors are used to configure BVSEL or L3VSEL, the resistors should be less than 250 Ω (see Table 16). Because PLL_CFG[0:4] must remain stable during normal operation, strong pull-up and pull-down resistors (1 k Ω or less) are recommended to configure these signals in order to protect against erroneous switching due to ground bounce, power supply noise or noise coupling.

During inactive periods on the bus, the address and transfer attributes may not be driven by any master and may, therefore, float in the high-impedance state for relatively long periods of time. Because the MPC7457 must continually monitor these signals for snooping, this float condition may cause excessive power draw by the input receivers on the MPC7457 or by other receivers in the system. These signals can be pulled up through weak (10-k Ω) pull-up resistors by the system, address bus driven mode enabled (see the *MPC7450 RISC Microprocessor Family Users' Manual* for more information about this mode), or they may be otherwise driven by the system during inactive periods of the bus to avoid this additional power draw. Preliminary studies have shown the additional power draw by the MPC7457 input receivers to be negligible and, in any event, none of these measures are necessary for proper device operation. The snooped address and transfer attribute inputs are: A[0:35], AP[0:4], TT[0:4], $\overline{\text{CI}}$, $\overline{\text{WT}}$, and $\overline{\text{GBL}}$.

If extended addressing is not used, A[0:3] are unused and must be pulled low to GND through weak pull-down resistors. If the MPC7457 is in 60x bus mode, DTI[0:3] must be pulled low to GND through weak pull-down resistors.

The data bus input receivers are normally turned off when no read operation is in progress and, therefore, do not require pull-up resistors on the bus. Other data bus receivers in the system, however, may require pull-ups, or that those signals be otherwise driven by the system during inactive periods by the system. The data bus signals are: D[0:63] and DP[0:7].

If address or data parity is not used by the system, and the respective parity checking is disabled through HID0, the input receivers for those pins are disabled, and those pins do not require pull-up resistors and should be left unconnected by the system. If all parity generation is disabled through HID0, all parity checking should also be disabled through HID0, and all parity pins may be left unconnected by the system.

The L3 interface does not normally require pull-up resistors. Unused L3_ADDR signals are driven low when the SRAM is configured to be less than 1 M in size via L3CR. For example, L3_ADD[18] will be driven low if the SRAM size is configured to be 2 M; likewise, L3_ADDR[18:17] will be driven low if the SRAM size is configured to be 1 M.

9.7 JTAG Configuration Signals

Boundary-scan testing is enabled through the JTAG interface signals. The $\overline{\text{TRST}}$ signal is optional in the IEEE 1149.1 specification, but is provided on all processors that implement the PowerPC architecture. While it is possible to force the TAP controller to the reset state using only the TCK and TMS signals, more reliable power-on reset performance will be obtained if the $\overline{\text{TRST}}$ signal is asserted during power-on reset. Because the JTAG interface is also used for accessing the common on-chip processor (COP) function, simply tying $\overline{\text{TRST}}$ to $\overline{\text{HRESET}}$ is not practical.

The COP function of these processors allows a remote computer system (typically, a PC with dedicated hardware and debugging software) to access and control the internal operations of the processor. The COP interface connects primarily through the JTAG port of the processor, with some additional status monitoring signals. The COP port

System Design Information

requires the ability to independently assert $\overline{\text{HRESET}}$ or $\overline{\text{TRST}}$ in order to fully control the processor. If the target system has independent reset sources, such as voltage monitors, watchdog timers, power supply failures, or push-button switches, the COP reset signals must be merged into these signals with logic.

The arrangement shown in [Figure 26](#) allows the COP port to independently assert $\overline{\text{HRESET}}$ or $\overline{\text{TRST}}$, while ensuring that the target can drive $\overline{\text{HRESET}}$ as well. If the JTAG interface and COP header will not be used, $\overline{\text{TRST}}$ should be tied to $\overline{\text{HRESET}}$ through a 0- Ω isolation resistor so that it is asserted when the system reset signal ($\overline{\text{HRESET}}$) is asserted, ensuring that the JTAG scan chain is initialized during power-on. While Freescale recommends that the COP header be designed into the system as shown in [Figure 26](#), if this is not possible, the isolation resistor will allow future access to $\overline{\text{TRST}}$ in the case where a JTAG interface may need to be wired onto the system in debug situations.

The COP header shown in [Figure 26](#) adds many benefits—breakpoints, watchpoints, register and memory examination/modification, and other standard debugger features are possible through this interface—and can be as inexpensive as an unpopulated footprint for a header to be added when needed.

The COP interface has a standard header for connection to the target system, based on the 0.025" square-post, 0.100" centered header assembly (often called a Berg header). The connector typically has pin 14 removed as a connector key.

There is no standardized way to number the COP header shown in [Figure 26](#); consequently, many different pin numbers have been observed from emulator vendors. Some are numbered top-to-bottom then left-to-right, while others use left-to-right then top-to-bottom, while still others number the pins counter clockwise from pin 1 (as with an IC). Regardless of the numbering, the signal placement recommended in [Figure 26](#) is common to all known emulators.

The $\overline{\text{QACK}}$ signal shown in [Figure 26](#) is usually connected to the PCI bridge chip in a system and is an input to the MPC7457 informing it that it can go into the quiescent state. Under normal operation this occurs during a low-power mode selection. In order for COP to work, the MPC7457 must see this signal asserted (pulled down). While shown on the COP header, not all emulator products drive this signal. If the product does not, a pull-down resistor can be populated to assert this signal. Additionally, some emulator products implement open-drain type outputs and can only drive $\overline{\text{QACK}}$ asserted; for these tools, a pull-up resistor can be implemented to ensure this signal is deasserted when it is not being driven by the tool. Note that the pull-up and pull-down resistors on the $\overline{\text{QACK}}$ signal are mutually exclusive and it is never necessary to populate both in a system. To preserve correct power-down operation, $\overline{\text{QACK}}$ should be merged via logic so that it also can be driven by the PCI bridge.

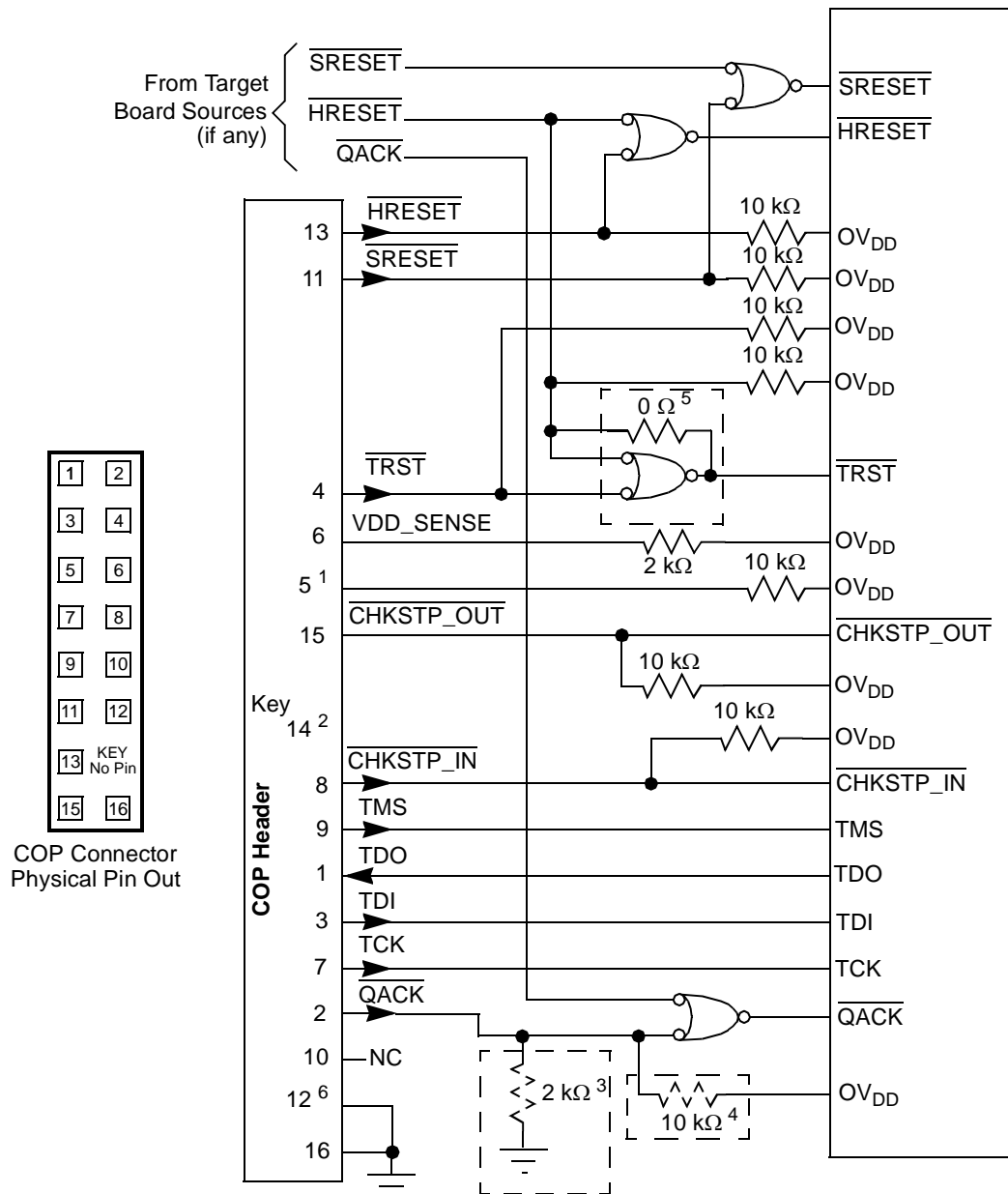


Figure 26. JTAG Interface Connection

9.8 Thermal Management Information

This section provides thermal management information for the ceramic ball grid array (CBGA) package for air-cooled applications. Proper thermal control design is primarily dependent on the system-level design—the heat sink, airflow, and thermal interface material. To reduce the die-junction temperature, heat sinks may be attached to the package by several methods—spring clip to holes in the printed-circuit board or package, and mounting clip and screw assembly (see Figure 25); however, due to the potential large mass of the heat sink, attachment through the printed-circuit board is suggested. If a spring clip is used, the spring force should not exceed 10 pounds.

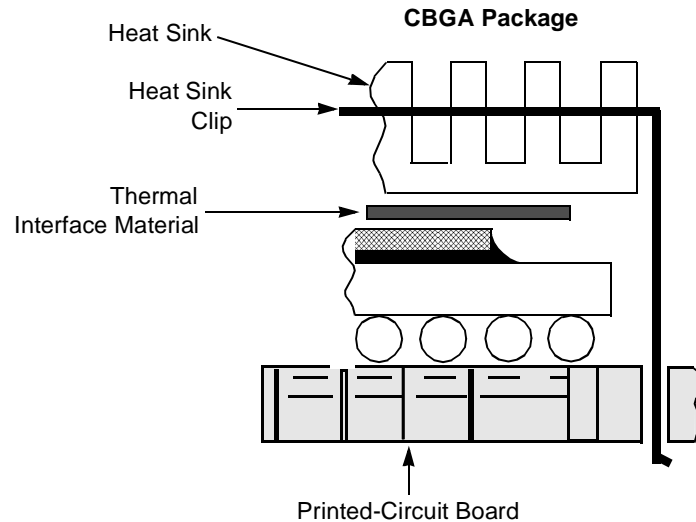


Figure 27. Package Exploded Cross-Sectional View with Several Heat Sink Options

The board designer can choose between several types of heat sinks to place on the MPC7457. There are several commercially available heat sinks for the MPC7457 provided by the following vendors:

Aavid Thermalloy 80 Commercial St. Concord, NH 03301 Internet: www.aavidthermalloy.com	603-224-9988
Alpha Novatech 473 Sapena Ct. #15 Santa Clara, CA 95054 Internet: www.alphanovatech.com	408-749-7601
International Electronic Research Corporation (IERC) 413 North Moss St. Burbank, CA 91502 Internet: www.ctscorp.com	818-842-7277
Tyco Electronics Chip Coolers™ P.O. Box 3668 Harrisburg, PA 17105-3668 Internet: www.chipcoolers.com	800-522-6752

Wakefield Engineering
 33 Bridge St.
 Pelham, NH 03076
 Internet: www.wakefield.com

603-635-5102

Ultimately, the final selection of an appropriate heat sink depends on many factors, such as thermal performance at a given air velocity, spatial volume, mass, attachment method, assembly, and cost.

9.8.1 Internal Package Conduction Resistance

For the exposed-die packaging technology, shown in Table 3, the intrinsic conduction thermal resistance paths are as follows:

- The die junction-to-case (actually top-of-die since silicon die is exposed) thermal resistance
- The die junction-to-ball thermal resistance

Figure 26 depicts the primary heat transfer path for a package with an attached heat sink mounted to a printed-circuit board.

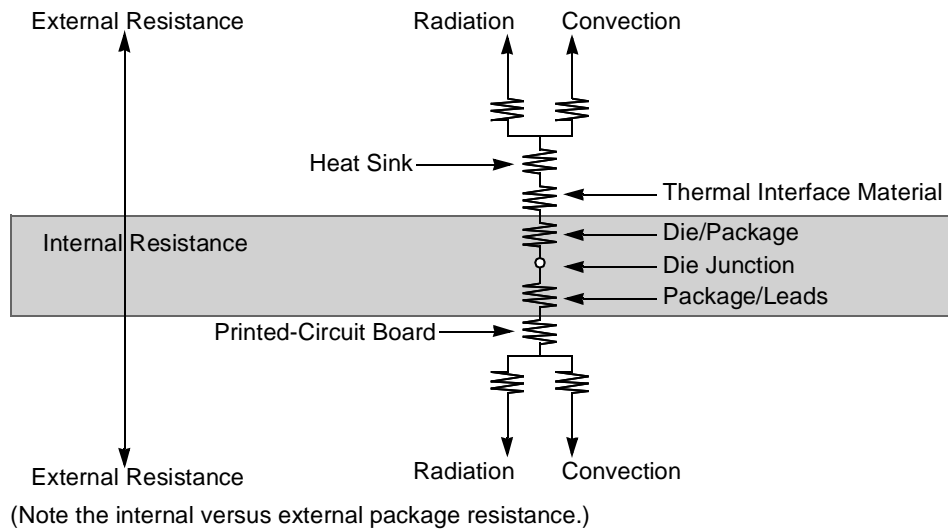


Figure 28. C4 Package with Heat Sink Mounted to a Printed-Circuit Board

Heat generated on the active side of the chip is conducted through the silicon, through the heat sink attach material (or thermal interface material), and finally to the heat sink where it is removed by forced-air convection.

Because the silicon thermal resistance is quite small, for a first-order analysis, the temperature drop in the silicon may be neglected. Thus, the thermal interface material and the heat sink conduction/convective thermal resistances are the dominant terms.

9.8.2 Thermal Interface Materials

A thermal interface material is recommended at the package lid-to-heat sink interface to minimize the thermal contact resistance. For those applications where the heat sink is attached by spring clip mechanism, Figure 27 shows the thermal performance of three thin-sheet thermal-interface materials (silicone, graphite/oil, fluoroether oil), a bare joint, and a joint with thermal grease as a function of contact pressure. As shown, the performance of these thermal interface materials improves with increasing contact pressure. The use of thermal grease significantly reduces the

System Design Information

interface thermal resistance. That is, the bare joint results in a thermal resistance approximately seven times greater than the thermal grease joint.

Often, heat sinks are attached to the package by means of a spring clip to holes in the printed-circuit board (see [Figure 25](#)). Therefore, the synthetic grease offers the best thermal performance, considering the low interface pressure and is recommended due to the high power dissipation of the MPC7457. Of course, the selection of any thermal interface material depends on many factors—thermal performance requirements, manufacturability, service temperature, dielectric properties, cost, etc.

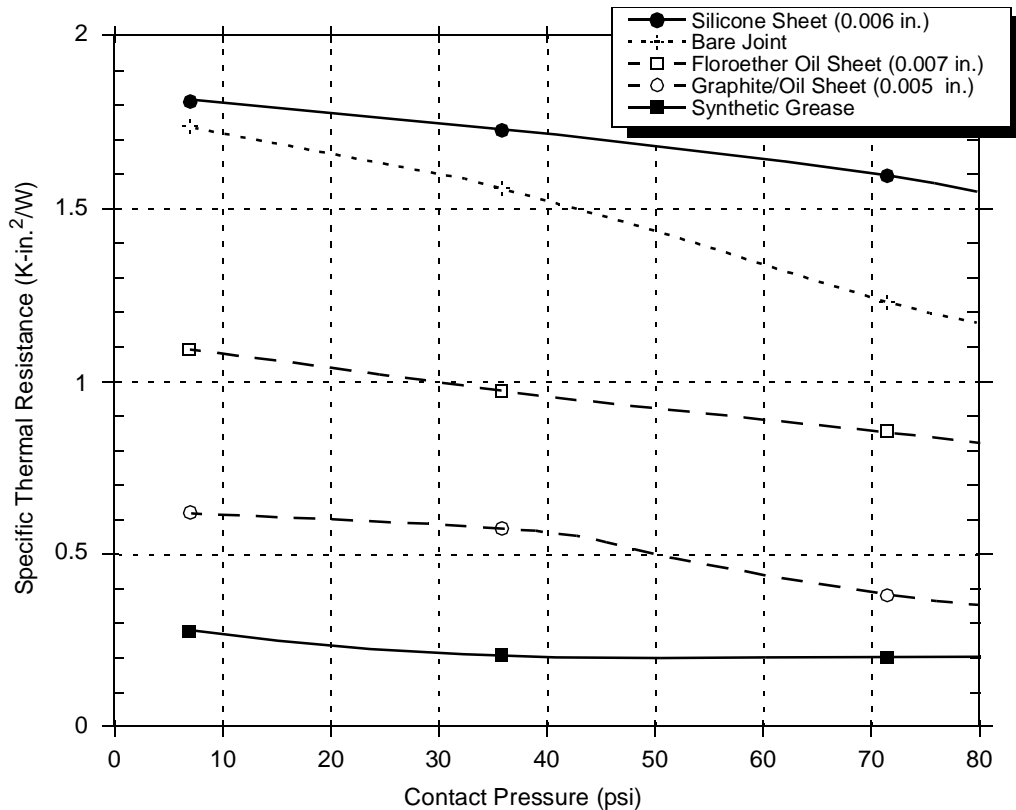


Figure 29. Thermal Performance of Select Thermal Interface Material

The board designer can choose between several types of thermal interface. Heat sink adhesive materials should be selected based on high conductivity, yet adequate mechanical strength to meet equipment shock/vibration requirements. There are several commercially available thermal interfaces and adhesive materials provided by the following vendors:

The Bergquist Company
18930 West 78th St.
Chanhassen, MN 55317
Internet: www.bergquistcompany.com

800-347-4572

Chomerics, Inc.
77 Dragon Ct.
Woburn, MA 01888-4014
Internet: www.chomerics.com

781-935-4850

Dow-Corning Corporation Dow-Corning Electronic Materials 2200 W. Salzburg Rd. Midland, MI 48686-0997 Internet: www.dow.com	800-248-2481
Shin-Etsu MicroSi, Inc. 10028 S. 51st St. Phoenix, AZ 85044 Internet: www.microsi.com	888-642-7674
Thermagon Inc. 4707 Detroit Ave. Cleveland, OH 44102 Internet: www.thermagon.com	888-246-9050

The following section provides a heat sink selection example using one of the commercially available heat sinks.

9.8.3 Heat Sink Selection Example

For preliminary heat sink sizing, the die-junction temperature can be expressed as follows:

$$T_j = T_I + T_r + (R_{\theta JC} + R_{\theta int} + R_{\theta sa}) \times P_d$$

where:

- T_j is the die-junction temperature
- T_I is the inlet cabinet ambient temperature
- T_r is the air temperature rise within the computer cabinet
- $R_{\theta JC}$ is the junction-to-case thermal resistance
- $R_{\theta int}$ is the adhesive or interface material thermal resistance
- $R_{\theta sa}$ is the heat sink base-to-ambient thermal resistance
- P_d is the power dissipated by the device

During operation, the die-junction temperatures (T_j) should be maintained less than the value specified in [Table 4](#). The temperature of air cooling the component greatly depends on the ambient inlet air temperature and the air temperature rise within the electronic cabinet. An electronic cabinet inlet-air temperature (T_a) may range from 30° to 40°C. The air temperature rise within a cabinet (T_r) may be in the range of 5° to 10°C. The thermal resistance of the thermal interface material ($R_{\theta int}$) is typically about 1.5°C/W. For example, assuming a T_a of 30°C, a T_r of 5°C, a CBGA package $R_{\theta JC} = 0.1$, and a typical power consumption (P_d) of 18.7 W, the following expression for T_j is obtained:

$$\text{Die-junction temperature: } T_j = 30^\circ\text{C} + 5^\circ\text{C} + (0.1^\circ\text{C/W} + 1.5^\circ\text{C/W} + \theta_{sa}) \times 18.7 \text{ W}$$

For this example, a $R_{\theta sa}$ value of 2.1°C/W or less is required to maintain the die junction temperature below the maximum value of [Table 4](#).

Though the die junction-to-ambient and the heat sink-to-ambient thermal resistances are a common figure-of-merit used for comparing the thermal performance of various microelectronic packaging technologies, one should exercise caution when only using this metric in determining thermal management because no single parameter can adequately describe three-dimensional heat flow. The final die-junction operating temperature is not only a function of the component-level thermal resistance, but the system-level design and its operating conditions. In addition to the component's power consumption, a number of factors affect the final operating die-junction

System Design Information

temperature—airflow, board population (local heat flux of adjacent components), heat sink efficiency, heat sink attach, heat sink placement, next-level interconnect technology, system air temperature rise, altitude, etc.

Due to the complexity and the many variations of system-level boundary conditions for today's microelectronic equipment, the combined effects of the heat transfer mechanisms (radiation, convection, and conduction) may vary widely. For these reasons, we recommend using conjugate heat transfer models for the board, as well as system-level designs.

For system thermal modeling, the MPC7447 and MPC7457 thermal model is shown in Figure 28. Four volumes will be used to represent this device. Two of the volumes, solder ball, and air and substrate, are modeled using the package outline size of the package. The other two, die, and bump and underfill, have the same size as the die. The silicon die should be modeled $9.64 \times 11.0 \times 0.74$ mm with the heat source applied as a uniform source at the bottom of the volume. The bump and underfill layer is modeled as $9.64 \times 11.0 \times 0.69$ mm (or as a collapsed volume) with orthotropic material properties: 0.6 W/(m • K) in the xy-plane and 2 W/(m • K) in the direction of the z-axis. The substrate volume is $25 \times 25 \times 1.2$ mm (MPC7447) or $29 \times 29 \times 1.2$ mm (MPC7457), and this volume has 18 W/(m • K) isotropic conductivity. The solder ball and air layer is modeled with the same horizontal dimensions as the substrate and is 0.9 mm thick. It can also be modeled as a collapsed volume using orthotropic material properties: 0.034 W/(m • K) in the xy-plane direction and 3.8 W/(m • K) in the direction of the z-axis.

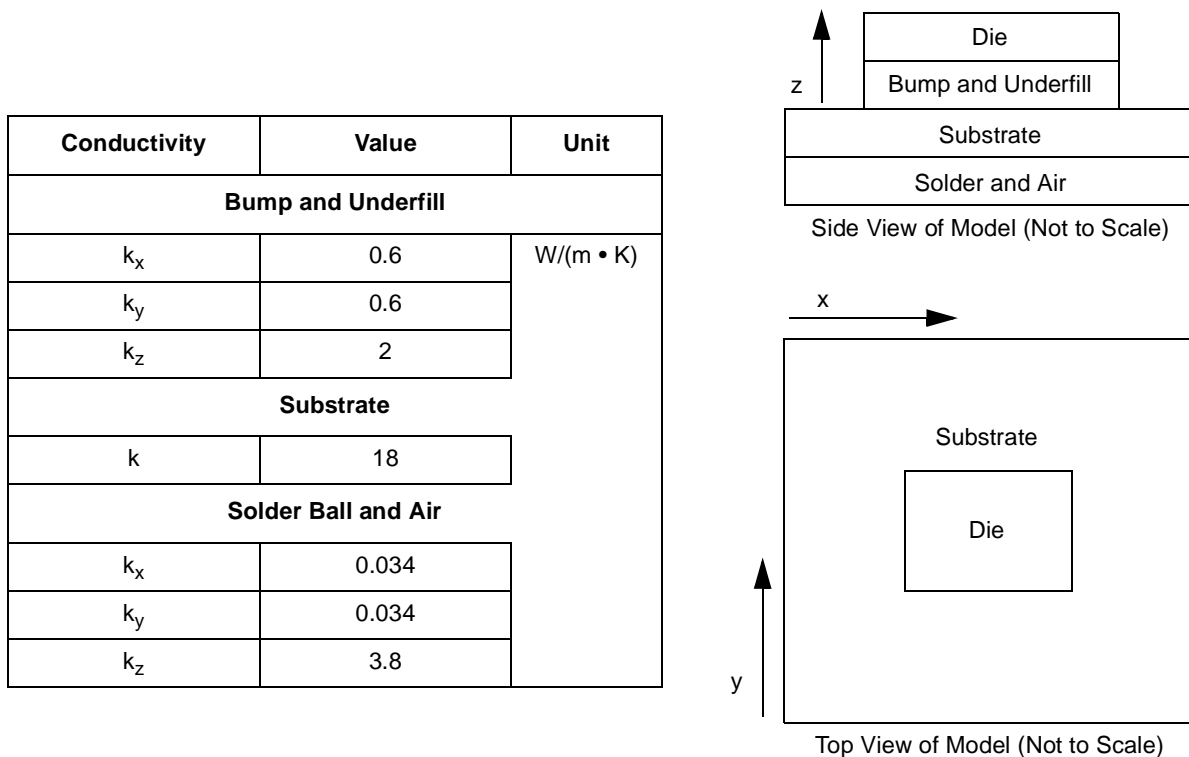


Figure 30. Recommended Thermal Model of MPC7447 and MPC7457

10 Document Revision History

Table 22 provides a revision history for this hardware specification.

Table 22. Document Revision History

Revision Number	Date	Substantive Change(s)
5	09/09/2004	Updated document to new Freescale template.
		Updated section numbering and changed reference from part number specifications to addendums.
		Added Rev. 1.2 devices, including increased L3 clock max frequency to 250 MHz and improved L3 AC timing.
		Table 5: Added CTE information.
		Table 8: Modified jitter specifications to conform to JEDEC standards, changed jitter specification to cycle-to-cycle jitter (instead of long- and short-term jitter); changed jitter bandwidth recommendations.
		Table 13: Deleted note 9 and renumbered.
		Table 14: Deleted note 5 and renumbered.
		Table 17: Revised note 6.
		Added Section 9.1.3.
		Section 9.2: Changed filter resistor recommendations. Recommend 10 Ω resistor for all production devices, including production Rev. 1.1 devices. 400 Ω resistor needed only for early Rev. 1.1 devices.
		Table 22: Reversed the order of revision numbers.
Added Tables 25 and 26.		
4.1		Section 9.1.1: Corrected note regarding different PLL configurations for earlier devices; all MPC7457 devices to date conform to this table.
		Section 9.6: Added information about unused L3_ADDR signals.
		Table 24: Changed title to include document order information for MPC74x7RXnnnnNx series part number specification.
4		Table 9: Corrected pin lists for input and output AC timing to correctly show $\overline{\text{HIT}}$ as an output-only signal
		Added specifications for 1267 MHz devices; removed specs for 1300 MHz devices.
		Section 5.2.3: Changed recommendations regarding use of L3 clock jitter in AC timing analysis. The L3 jitter is now fully comprehended in the AC timing specs and does not need to be included in the timing analysis.

Table 22. Document Revision History (continued)

Revision Number	Date	Substantive Change(s)
3		Corrected numerous errors in lists of pins associated with t_{KHOV} , t_{KHOX} , t_{IVKH} , and t_{IXKH} in Table 9.
		Added support for 1.5 V L3 interface voltage; issues fixed in Rev. 1.1.
		Corrected typos in Table 12.
		Added data to Table 2.
		Clarified address bus pull-up resistor recommendations in Section 1.9.6.
		Modified Table 9, Figure 5, and Figure 6 to more accurately show when the mode select inputs ($\overline{BMODE}[0:1]$, L3VSEL, BVSEL) are sampled and AC timing requirements
		Table 10: Added skew and jitter values.
		Table 14: Added AC timing values.
		Table 24: Updated to reflect past and current part numbers not fully covered by this document.
		Table 6: Removed CV_{IH} and CV_{IL} ; V_{IH} and V_{IL} for SYCLK input is the same as for other input signals, and is now noted accordingly in this table.
		Table 7: Removed Doze mode power entry (but left footnote 4 for clarity); documentation change only.
		Nontechnical formatting
2		Added substrate capacitor information in Sections 1.8.3 and 1.8.6.
		Increased minimum processor and VCO frequencies in Table 8 from 500 and 1000 MHz to 600 and 1200 MHz (respectively).
		Corrected maximum processor frequency for 1300 MHz devices in Table 8 (changed from 1333 to 1300 MHz).
		Added value for $t_{L3CSKW1}$ Table 10.
		Added L3OHCR information in Section 1.5.2.4.1.
		Added values for t_{CO} and t_{ECI} to Table 11.
		Added Note 8 to Table 13 and Note 6 to Table 14.
		Changed resistor value in PLL filter in Figure 25 from 10 Ω to 400 Ω .
		Added 867 MHz speed grade.
		Corrected Product Code in Tables 22 and 23.
		Added pull-up/pull-down recommendations for $\overline{CKSTP_IN}$ and PLL_CFG[0:4] to Section 1.9.6.
1.1		Nontechnical reformatting.

Table 22. Document Revision History (continued)

Revision Number	Date	Substantive Change(s)
1		Removed support for 1.5 V L3 interface voltage from Tables 3 and 4. 1.5 V I/O voltage is not supported in current MPC7457 devices.
		Added package thermal characteristics values to Table 5, made minor revisions to Section 1.9.8.
		Added preliminary AC timing values to Tables 10 and 12.
		Added footnotes to Table 17.
0		Initial release.

11 Part Numbering and Marking

Ordering information for the parts fully covered by this specification document is provided in [Section 11.1, “Part Numbers Fully Addressed by This Document.”](#) Note that the individual part numbers correspond to a maximum processor core frequency. For available frequencies, contact your local Freescale sales office. In addition to the processor frequency, the part numbering scheme also includes an application modifier which may specify special application conditions. Each part number also contains a revision level code which refers to the die mask revision number. [Section 11.2, “Part Numbers Not Fully Addressed by This Document,”](#) lists the part numbers which do not fully conform to the specifications of this document. These special part numbers require an additional document called a referred to as a hardware specification addendum.

11.1 Part Numbers Fully Addressed by This Document

[Table 23](#) provides the Freescale part numbering nomenclature for the MPC7457.

Table 23. Part Numbering Nomenclature

MC	74x7	RX	nnnn	L	x
Product Code	Part Identifier	Package	Processor Frequency ¹	Application Modifier	Revision Level
PPC ² MC	7457 7447	RX = CBGA	867 1000 1200 1267	L: 1.3 V ± 50 mV 0° to 105°C	B: 1.1; PVR = 8002 0101
MC	7457		867 1000 1200 1267		C: 1.2; PVR = 8002 0102

Notes:

- Processor core frequencies supported by parts addressed by this specification only. Parts addressed by a hardware specification addendum may support other maximum core frequencies.
- The P prefix in a Freescale part number designates a “Pilot Production Prototype” as defined by Freescale SOP 3-13. These parts have only preliminary reliability and characterization data. Before pilot production prototypes may be shipped, written authorization from the customer must be on file in the applicable sales office acknowledging the qualification status and the fact that product changes may still occur while shipping pilot production prototypes.

11.2 Part Numbers Not Fully Addressed by This Document

Parts with application modifiers or revision levels not fully addressed are described in a separate addendum, which supplement and supersede this hardware specification. As such parts are released, these specifications will be listed in this section.

Table 24. Part Numbers Addressed by MPC74x7RXnnnnNx Series Hardware Specifications Addendum (Document Order No. MPC7457ECS1AD)

MC	74x7	RX	nnnn	N	x
Product Code	Part Identifier	Package	Processor Frequency	Application Modifier	Revision Level
PPC	7457	RX = CBGA	1000 867 733 600	N: 1.1 V ± 50 mV 0° to 105°C	B: 1.1; PVR = 8002 0101
	7447		1000 867		
MC	7447		1000 867 733 600		B: 1.1; PVR = 8002 0101
	7457		1000 867 733 600		C: 1.2; PVR = 8002 0102

Table 25. Part Numbers Addressed by MPC7457TRXnnnnLB Series Hardware Specifications Addendum (Document Order No. MPC7457ECS2AD)

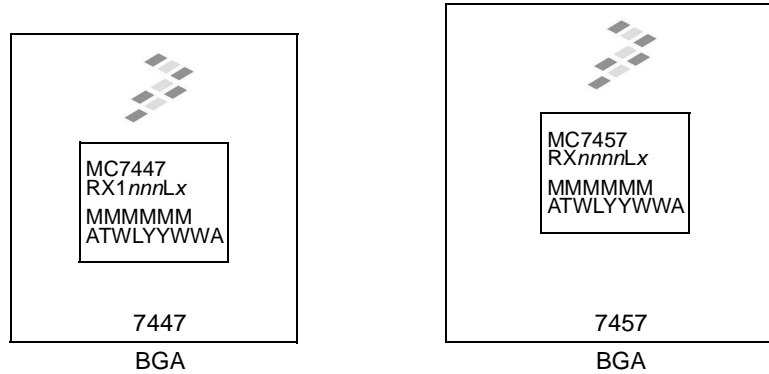
MC	7457	T	RX	nnnn	L	x
Product Code	Part Identifier	Specification Modifier	Package	Processor Frequency	Application Modifier	Revision Level
MC	7457	T = Extended Temperature Device	RX = CBGA	1000 1267	L: 1.3 V ± 50 mV -40° to 105°C	C: 1.2; PVR = 8002 0102

Table 26. Part Numbers Addressed by MPC7457TRXnnnnNx Series Hardware Specifications Addendum (Document Order No. MPC7457ECS3AD)

MC	74x7	T	RX	nnnn	N	x
Product Code	Part Identifier	Specification Modifier	Package	Processor Frequency	Application Modifier	Revision Level
MC	7447	T = Extended Temperature Device	RX = CBGA	733 1000	N: 1.1 V ± 50 mV -40° to 105°C	B: 1.1; PVR = 8002 0101
	7457			C: 1.2; PVR = 8002 0102		

11.3 Part Marking

Parts are marked as the examples shown in [Figure 32](#).



Notes:

MMMMMM is the 6-digit mask number.
 ATWLYYWWA is the traceability code.

Figure 31. Part Marking for BGA Device

THIS PAGE INTENTIONALLY LEFT BLANK

THIS PAGE INTENTIONALLY LEFT BLANK

How to Reach Us:

Home Page:

www.freescale.com

email:

support@freescale.com

USA/Europe or Locations Not Listed:

Freescale Semiconductor
Technical Information Center, CH370
1300 N. Alma School Road
Chandler, Arizona 85224
(800) 521-6274
480-768-2130
support@freescale.com

Europe, Middle East, and Africa:

Freescale Halbleiter Deutschland GmbH
Technical Information Center
Schatzbogen 7
81829 Muenchen, Germany
+44 1296 380 456 (English)
+46 8 52200080 (English)
+49 89 92103 559 (German)
+33 1 69 35 48 48 (French)
support@freescale.com

Japan:

Freescale Semiconductor Japan Ltd.
Technical Information Center
3-20-1, Minami-Azabu, Minato-ku
Tokyo 106-0047 Japan
0120 191014
+81 3 3440 3569
support.japan@freescale.com

Asia/Pacific:

Freescale Semiconductor Hong Kong Ltd.
Technical Information Center
2 Dai King Street
Tai Po Industrial Estate,
Tai Po, N.T., Hong Kong
+800 2666 8080
support.asia@freescale.com

For Literature Requests Only:

Freescale Semiconductor
Literature Distribution Center
P.O. Box 5405
Denver, Colorado 80217
(800) 441-2447
303-675-2140
Fax: 303-675-2150
LDCForFreescaleSemiconductor@
hibbertgroup.com

Information in this document is provided solely to enable system and software implementers to use Freescale Semiconductor products. There are no express or implied copyright licenses granted hereunder to design or fabricate any integrated circuits or integrated circuits based on the information in this document.

Freescale Semiconductor reserves the right to make changes without further notice to any products herein. Freescale Semiconductor makes no warranty, representation or guarantee regarding the suitability of its products for any particular purpose, nor does Freescale Semiconductor assume any liability arising out of the application or use of any product or circuit, and specifically disclaims any and all liability, including without limitation consequential or incidental damages. "Typical" parameters which may be provided in Freescale Semiconductor data sheets and/or specifications can and do vary in different applications and actual performance may vary over time. All operating parameters, including "Typicals" must be validated for each customer application by customer's technical experts. Freescale Semiconductor does not convey any license under its patent rights nor the rights of others. Freescale Semiconductor products are not designed, intended, or authorized for use as components in systems intended for surgical implant into the body, or other applications intended to support or sustain life, or for any other application in which the failure of the Freescale Semiconductor product could create a situation where personal injury or death may occur. Should Buyer purchase or use Freescale Semiconductor products for any such unintended or unauthorized application, Buyer shall indemnify and hold Freescale Semiconductor and its officers, employees, subsidiaries, affiliates, and distributors harmless against all claims, costs, damages, and expenses, and reasonable attorney fees arising out of, directly or indirectly, any claim of personal injury or death associated with such unintended or unauthorized use, even if such claim alleges that Freescale Semiconductor was negligent regarding the design or manufacture of the part.

Freescale™ and the Freescale logo are trademarks of Freescale Semiconductor, Inc. The described product is a PowerPC microprocessor. The PowerPC name is a trademark of IBM Corp. and used under license. All other product or service names are the property of their respective owners.

© Freescale Semiconductor, Inc. 2004.

MPC7457EC

Rev. 5

09/2004

